

Input selector switch for high definition displays

BA7658AFS

The BA7658AFS is an IC designed for high definition displays, and has an internal selector circuit for broadband RGB signals and HD / VD signals, a synchronization separator circuit, and a NUTEK signal detector circuit. This IC chip simplifies the configuration of input blocks for high-end displays.

●Applications

CRT displays, HDTV, video board for personal computer, etc.

●Features

- 1) Operates on a single 5V power supply.
- 2) Internal broadband RGB selector with a frequency characteristic of 230MHz (- 3dB)
- 3) Internal HD / VD selector.
- 4) Internal separator for synchronization signal superimposed on the G signal.
- 5) Internal detector for NUTEK power saving signals.

●Absolute maximum ratings (Ta = 25°C)

Parameter	Symbol	Limits	Unit
Power supply voltage	V _{cc}	7.0	V
Power dissipation	P _d	850*	mW
Operating temperature	T _{opr}	- 25 ~ + 75	°C
Storage temperature	T _{stg}	- 55 ~ + 125	°C

* Reduced by 8.5mW for each increase in Ta of 1°C over 25°C.

●Recommended operating conditions (Ta = 25°C)

Parameter	Symbol	Min.	Typ.	Max.	Unit
Power supply voltage	V _{cc}	4.5	5.0	5.5	V

●Block diagram

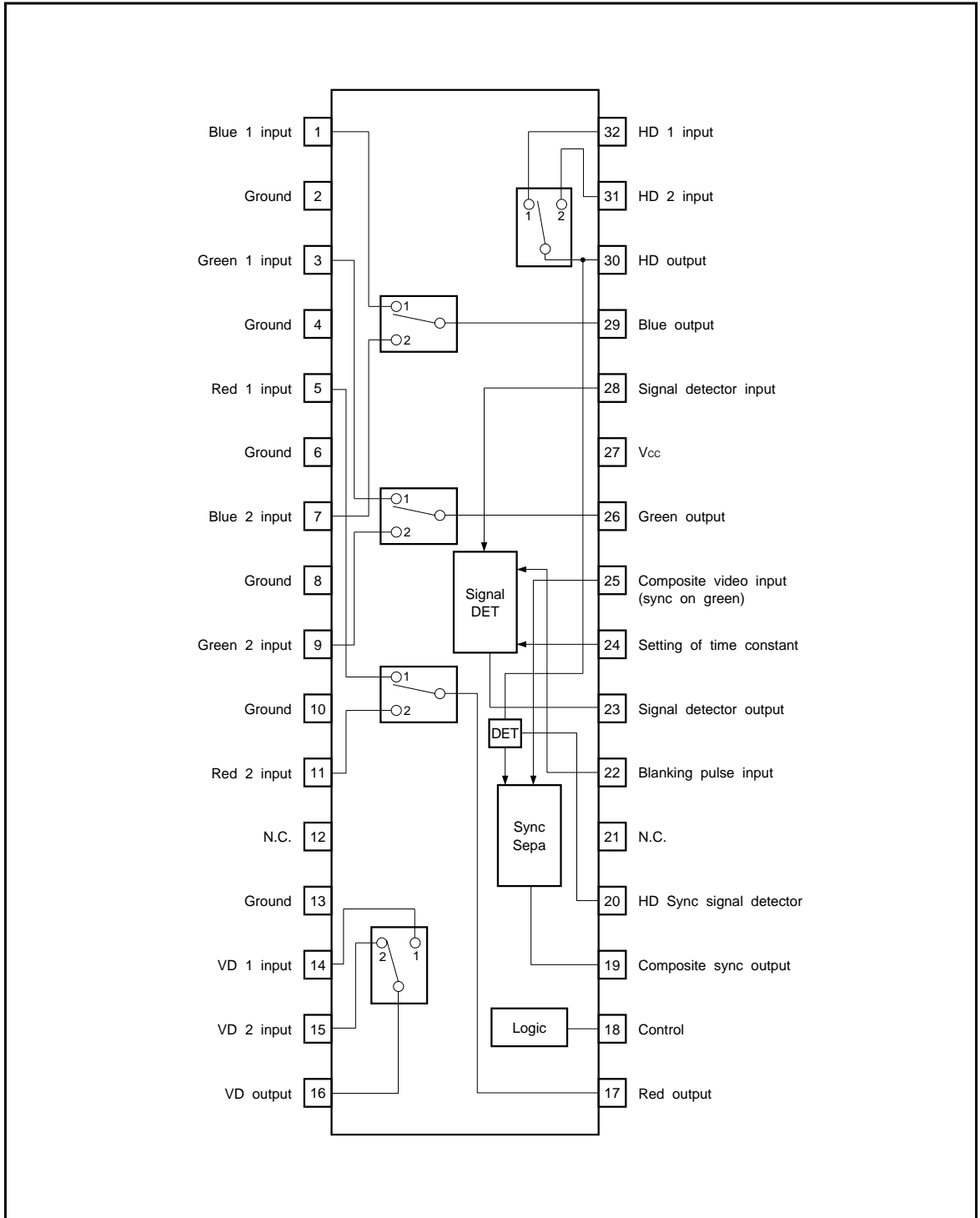

●Pin descriptions

Pin No.	Pin name	Function
1	Blue 1 input	B1 color signal input
2	Ground	GND
3	Green 1 input	G1 color signal input
4	Ground	GND
5	Red 1 input	R1 color signal input
6	Ground	GND
7	Blue 2 input	B2 color signal input
8	Ground	GND
9	Green 2 input	G2 color signal input
10	Ground	GND
11	Red 2 input	R2 color signal input
12	N.C.	N.C.
13	Ground	GND
14	VD 1 input	Vertical synchronization signal VD1 input
15	VD 2 input	Vertical synchronization signal VD2 input
16	VD output	Vertical synchronization signal VD output
17	Red output	R color signal output
18	Control	CTL (H = IN1, L = IN2)
19	Composite sync output	Synchronization signal output

Pin No.	Pin name	Function
20	HD Sync signal detector	Synchronization signal detector
21	N.C.	N.C.
22	Blanking pulse input	Blanking pulse input
23	Signal detector output	Signal detector output
24	Setting of time constant	Setting of time constant
25	Composite video input	Composite video input
26	Green output	G signal output
27	V _{CC}	V _{CC}
28	Signal detector input	Signal detector input
29	Blue output	B signal output
30	HD output	Horizontal synchronization signal HD output
31	HD 2 input	Horizontal synchronization signal HD2 input
32	HD 1 input	Horizontal synchronization signal HD1 input

●Output selection setting table

CTL	B	G	R	HD	VD
H	IN1	IN1	IN1	IN1	IN1
L	IN2	IN2	IN2	IN2	IN2

● Input / output circuits

R. G. B. input

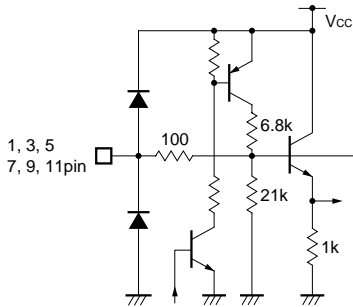

R. G. B. output

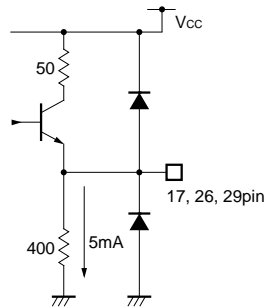

Control

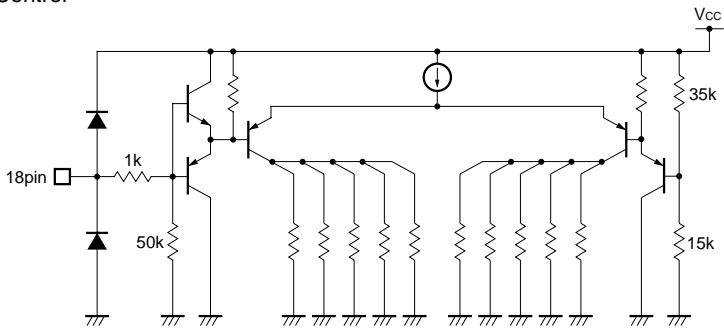

Composite video input

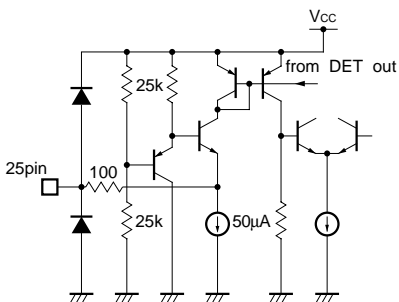

Composite sync output

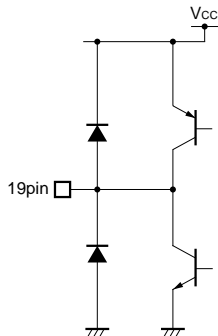

Setting of time constant

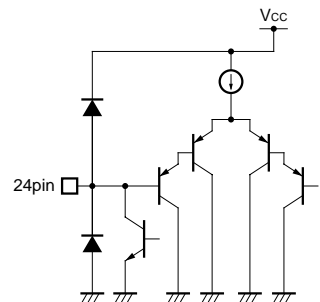

Signal detector output

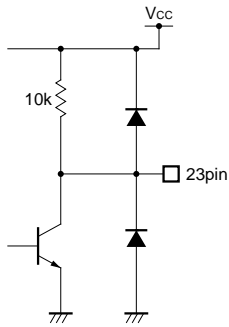

Signal detector input

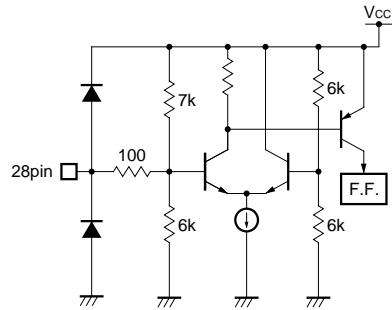

HD. VD input

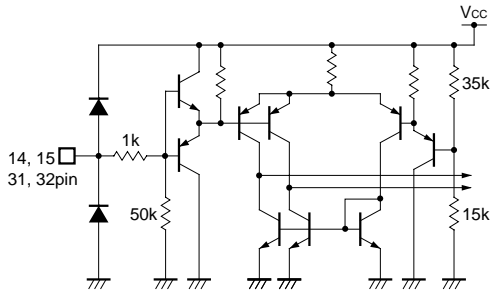

HD. VD input

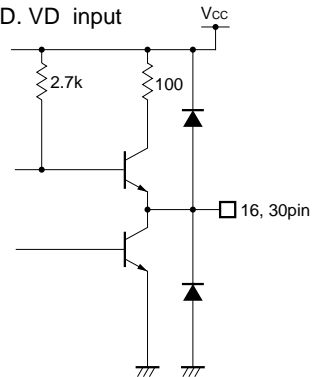

HD sync signal detector

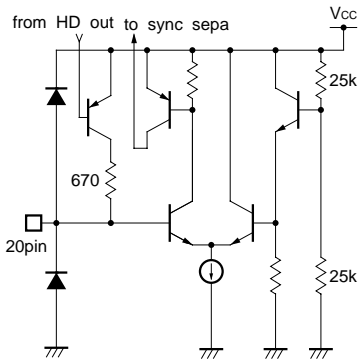

●Electrical characteristics (unless otherwise noted, Ta = 25°C, Vcc = 5.0V)

Parameter	Symbol	Min.	Typ.	Max.	Unit	Conditions	Measurement circuit
Quiescent current	I _{CC}	26	37	48	mA		Fig. 1
(Analog switches)							
Maximum output level	V _{om}	2.8	—	—	V _{P-P}	f = 1kHz	Fig. 1
Voltage gain	G _V	-1.0	-0.5	0	dB	f = 1MHz, V _{IN} = 1V _{P-P}	Fig. 1
Voltage gain differential (Input pin)	ΔG _{V1}	-0.2	0	0.2	dB	f = 1MHz, V _{IN} = 1V _{P-P}	Fig. 1
Voltage gain differential (Block)	ΔG _{VB}	-0.2	0	0.2	dB	f = 1MHz, V _{IN} = 1V _{P-P}	Fig. 1
Input pin crosstalk 1	CTI1	—	-50	-40	dB	f = 10MHz, V _{IN} = 1V _{P-P}	Fig. 2
Block crosstalk 1	CTB1	—	-50	-40	dB	f = 10MHz, V _{IN} = 1V _{P-P}	Fig. 2
(Digital switches)							
Input voltage "H" level	V _{IH}	1.8	—	—	V		Fig. 1
Input voltage "L" level	V _{IL}	—	—	1.2	V		Fig. 1
Input current "H" level	I _{IH}	80	100	130	μA	V _{IN} = 5.0V	Fig. 1
Input current "L" level	I _{IL}	-3	-1	—	μA	V _{IN} = 0V	Fig. 1
Rising time	T _R	—	30	50	ns		Fig. 1
Falling time	T _F	—	30	50	ns		Fig. 1
Rising delay time	T _{RD}	—	30	50	ns		Fig. 1
Falling delay time	T _{FD}	—	40	60	ns		Fig. 1
Output voltage "H" level	V _{OH}	3.8	4.2	—	V		Fig. 1
Output voltage "L" level	V _{OL}	—	0.2	0.4	V		Fig. 1
Output current "H" level	I _{OH}	-400	—	—	μA		Fig. 1
Output current "L" level	I _{OL}	4	—	—	mA		Fig. 1
(SYNC separation unit)							
Minimum SYNC separation level	V _{SMin.}	—	—	50	mV _{P-P}		Fig. 1
Output voltage "H" level	V _{OH}	4.5	4.8	—	V		Fig. 1
Output voltage "L" level	V _{OL}	—	0.2	0.5	V		Fig. 1
Output current "H" level	I _{OH}	-1.8	—	—	mA		Fig. 1
Output current "L" level	I _{OL}	3.6	—	—	mA		Fig. 1
Rising time	T _R	—	60	110	ns		Fig. 1
Falling time	T _F	—	50	100	ns		Fig. 1
Rising delay time	T _{RD}	—	100	150	ns		Fig. 1
Falling delay time	T _{FD}	—	150	200	ns		Fig. 1

Parameter	Symbol	Min.	Typ.	Max.	Unit	Conditions	Measurement circuit
(Signal detection block)							
Minimum signal detection level	VDMin.	320	400	480	mV _{P-P}		Fig. 1
Minimum signal detection time	TDMin.	—	—	30	ns		Fig. 1
(Blanking input)							
Input voltage "H" level	V _{IH}	3	—	—	V		Fig. 1
Input voltage "L" level	V _{IL}	—	—	1.5	V		Fig. 1
Input current "H" level	I _{IH}	—	120	180	μA	V _{IN} = 5.0V	Fig. 1
Input current "L" level	I _{IL}	-3	0	—	μA	V _{IN} = 0V	Fig. 1
(Signal detection output)							
Output voltage "H" level	V _{OH}	4.5	5.0	—	V	I _o = 0	Fig. 1
Output voltage "L" level	V _{OL}	—	0.2	0.5	V		Fig. 1
Output current "L" level	I _{OL}	1.2	—	—	mA		Fig. 1
Pull-up resistance	RL	7	10	13	kΩ		Fig. 1
(Control block)							
Input voltage "H" level	V _{IH}	1.8	—	—	V		Fig. 1
Input voltage "L" level	V _{IL}	—	—	1.2	V		Fig. 1
Input current "H" level	V _{IH}	80	100	130	μA	V _{IN} = 5.0V	Fig. 1
Input current "L" level	V _{IL}	-3	-1	—	μA	V _{IN} = 0V	Fig. 1

● Guaranteed design parameters (unless otherwise noted, T_a = 25°C, V_{CC} = 5.0V)

Parameter	Symbol	Min.	Typ.	Max.	Unit	Conditions	Measurement circuit
(Analog switch unit)							
Frequency characteristics	Gf	-6	-3	-1	dB	1MHz / 230MHz, V _{IN} = 1V _{P-P}	Fig. 2
Input pin frequency characteristic deviation	ΔGfI	-1	0	+1	dB	1MHz / 100MHz, V _{IN} = 1V _{P-P}	Fig. 2
Block frequency characteristic deviation	ΔGfB	-1	0	+1	dB	1MHz / 230MHz, V _{IN} = 1V _{P-P}	Fig. 2
Input pin crosstalk 2	CTIZ	—	-30	-15	dB	f = 230MHz, V _{IN} = 1V _{P-P}	Fig. 2
Block crosstalk 2	CTBZ	—	-30	-15	dB	f = 230MHz, V _{IN} = 1V _{P-P}	Fig. 2

● Measurement circuit

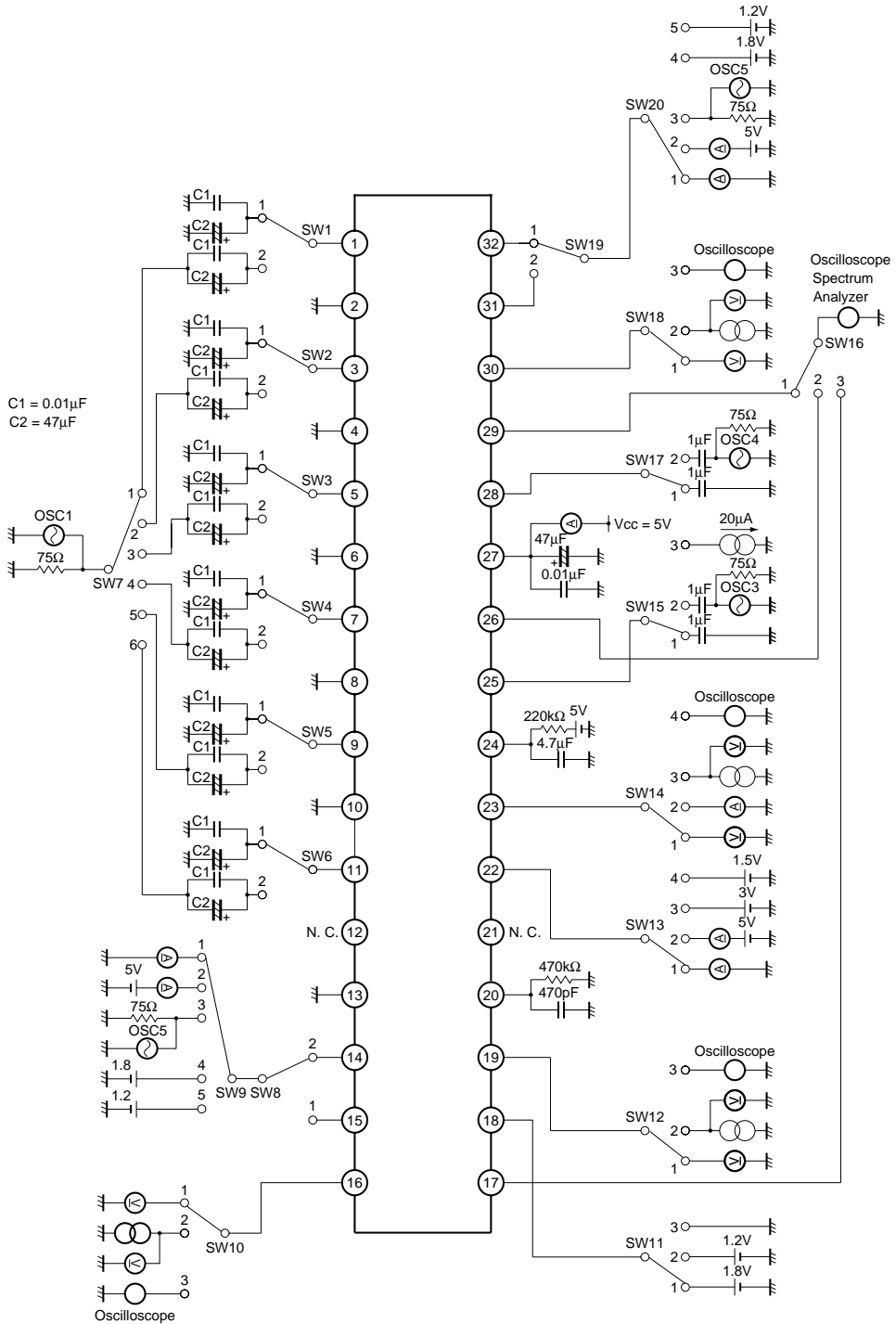

Fig. 1

● Measurement circuit for frequency characteristics and crosstalk characteristics

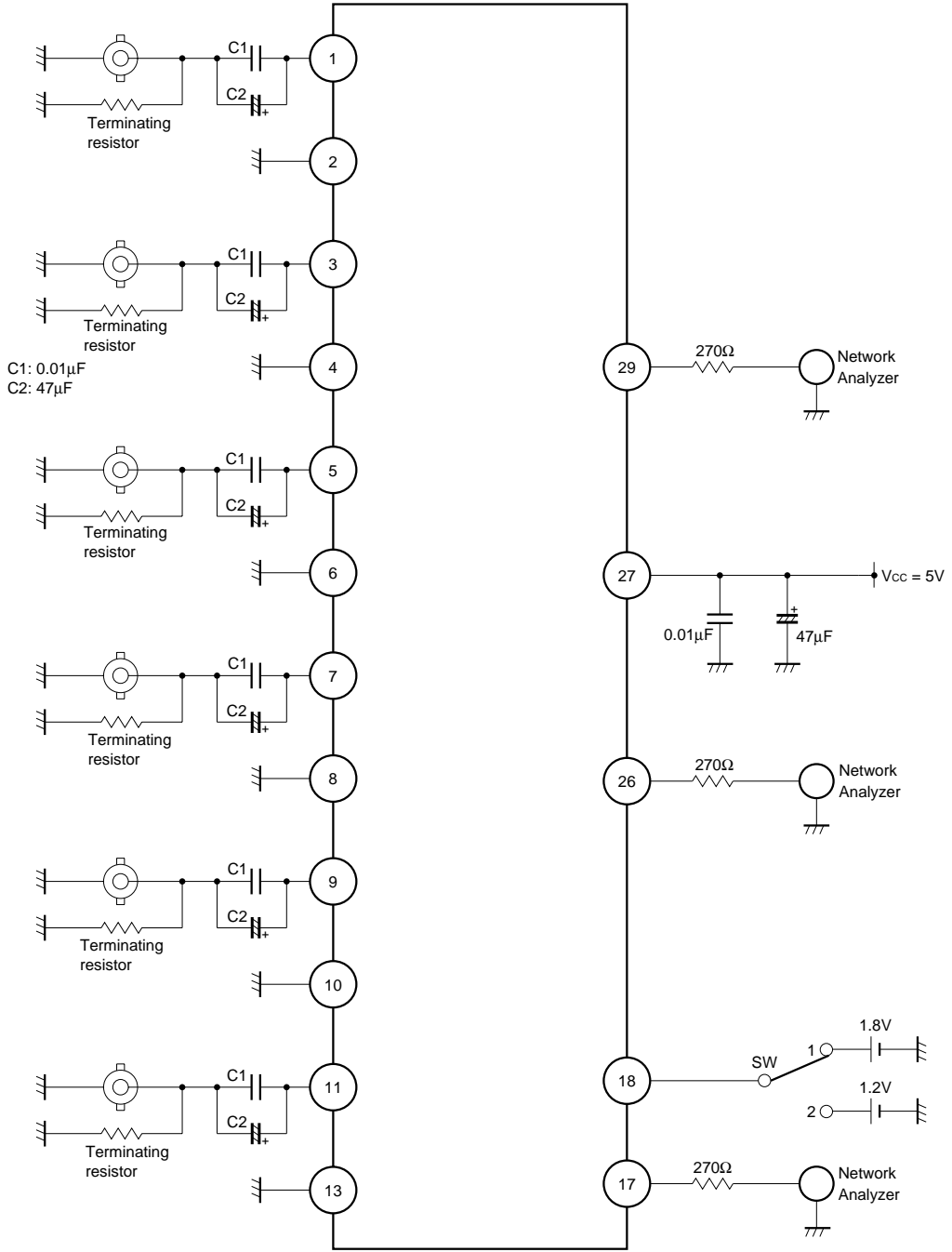

Fig. 2

● Procedure for measurement of frequency characteristics and crosstalk characteristics

(1) Frequency characteristics 1

Use an oscilloscope to input a sine wave ($V_{IN} = 1.0V_{P-P}$, $f = 1\text{MHz} / 150\text{MHz}$) to the color signal input pins. Set the switch to 1 to select B1, G1 and R1, or to 2 to select B2, G2 and R2.

$$Gf1 = Gv (f = 1\text{MHz}) - Gv (150\text{MHz}) \text{ [dB]}$$

(2) Frequency characteristic 2

Use an oscilloscope to input a sine wave ($V_{IN} = 1.0V_{P-P}$, $f = 1\text{MHz} / 230\text{MHz}$) to the color signal input pins. Set the switch to 1 to select B1, G1 and R1, or to 2 to select B2, G2 and R2.

$$Gf1 = Gv (f = 1\text{MHz}) - Gv (250\text{MHz}) \text{ [dB]}$$

(3) Input pin crosstalk 1

Use an oscilloscope to input a sine wave ($V_{IN} = 1.0V_{P-P}$, $f = 10\text{MHz}$) to IN1. Connect IN2 to the ground through a capacitor. Set the switch to 2, input to IN2, then measure.

$$CT11 = 20\log (V_{OUT} / V_{IN}) \text{ [dB]}$$

(4) Input pin crosstalk 2

Use an oscillator to input a sine wave ($V_{IN} = 1.0V_{P-P}$, $f = 230\text{MHz}$) to IN1. Connect IN2 to the ground through a

capacitor. Set the switch to 2, input to IN2, then measure.

$$CT12 = 20\log (V_{OUT} / V_{IN}) \text{ [dB]}$$

(5) Block crosstalk 1

Use an oscillator to input a sine wave ($V_{IN} = 1.0V_{P-P}$, $f = 10\text{MHz}$) to G1 and R1. Connect B1 to the ground through a capacitor. Set the switch to 1 and measure the B output.

$$CTB1B = 20\log (V_{OUTB} / V_{INR1}) \text{ [dB]}$$

Similarly,

$$CTB1G = 20\log (V_{OUTG} / V_{INR1}) \text{ [dB]}$$

$$CTB1R = 20\log (V_{OUTR} / V_{INB1}) \text{ [dB]}$$

(6) Block crosstalk 2

Use an oscillator to input a sine wave ($V_{IN} = 1.0V_{P-P}$, $f = 230\text{MHz}$) to G1 and R1. Connect B1 to the ground through a capacitor. Set the switch to 1 and measure the B output.

$$CTB2B = 20\log (V_{OUTB} / V_{INR1}) \text{ [dB]}$$

Similarly,

$$CTB2G = 20\log (V_{OUTG} / V_{INR1}) \text{ [dB]}$$

$$CTB2R = 20\log (V_{OUTR} / V_{INB1}) \text{ [dB]}$$

●Circuit operation

(1) Analog switches

Switch between the two sets of R, G and B color signals. IN1 is selected by impressing the high level voltage on the CTL pin, IN2 by impressing the low level voltage.

(2) Digital switches

These switch between the two sets of HD and VD synchronization signals. HD and VD synchronization signals for IN1 are output by impressing the high level voltage on the CTL pin, HD and VD synchronization signals for IN2 by impressing the low level voltage.

(3) Synchronization separation block

Outputs the synchronization signals by separating them from composite signals (Sync on Green). When HD signals are being input, the synchronization signal detector stops the synchronization separator. The low

level voltage is output. The time that the synchronization separator is stopped can be set by changing the time constant attached to the synchronization signal detection pin.

(4) Signal detection block

When the signal input exceeds the level set inside the IC (typically 400mV_{P-P}, V_{CC} = 5.0V), the high level voltage is output to the color signal detection output pin. The low level voltage is output when the signal input is lower than the set level. The quiescent circuit reaction time can be set by changing the time constant attached to pin used to set the time constant for color signal detection. The signal detector stops while the high level is being input to the blanking pulse input pin, thereby preventing malfunctioning due setup signal block during the synchronization signal period.

The relationship between inputs and outputs

Input			Output		
HD	VD	Sync on Green	HD	VD	Composite Sync
—	—	○	—	—	○
○	—	○	○	—	—
—	○	○	—	○	○
○	○	○	○	○	—
○	—	—	○	—	—
—	○	—	—	○	—
○	○	—	○	○	—

●Application example

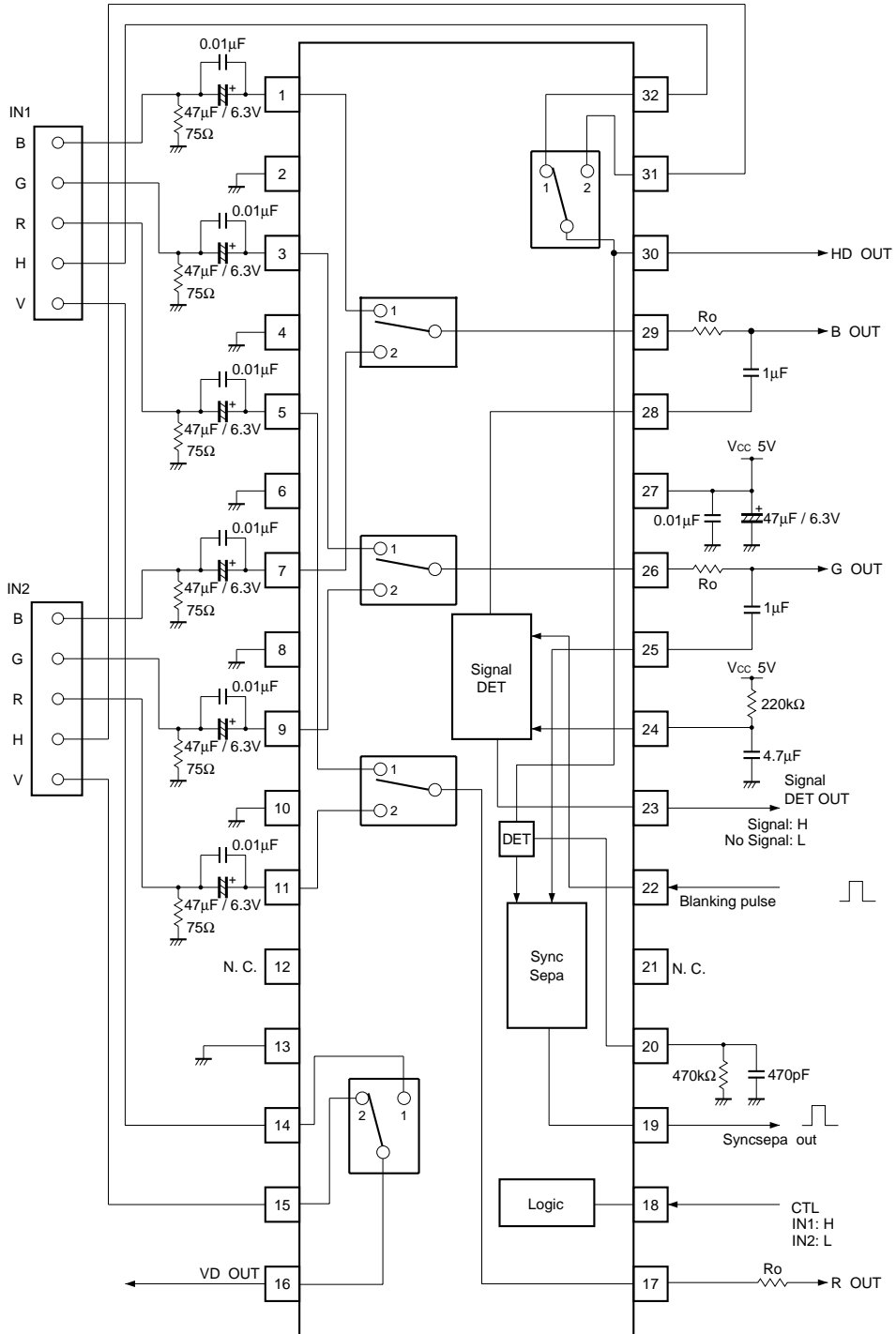

Fig. 3

●Electrical characteristic curves

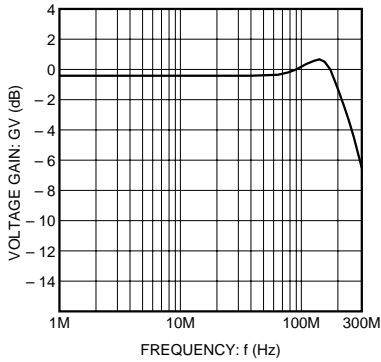

Fig. 4 Frequency characteristics

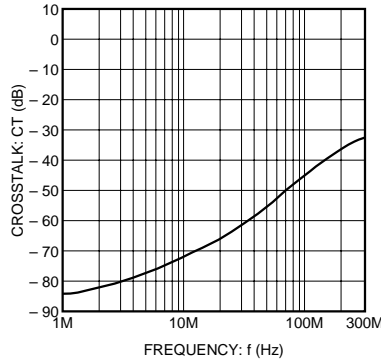
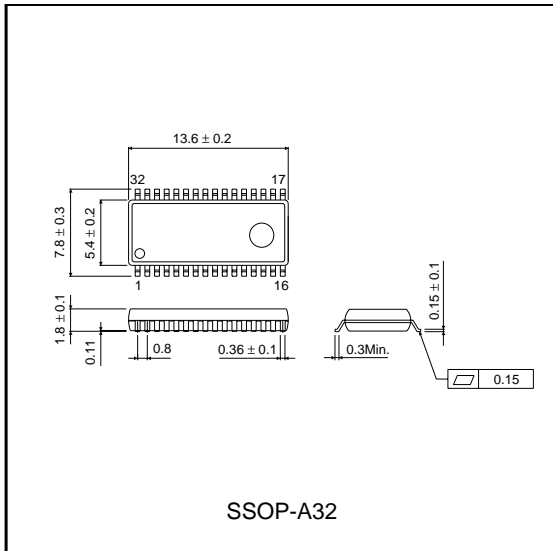

Fig. 5 Interchannel crosstalk characteristics

●Operation notes

Resistors attached to the analog switch block output
 Frequency characteristics of the analog switches vary according to the output load capacity. Set the attached resistor so that frequency characteristics remain flat. A too-large resistance will lower the characteristics peak.

●External dimensions (Units: mm)



This datasheet has been downloaded from:

www.DatasheetCatalog.com

Datasheets for electronic components.



LittleDiode supplies new, hard to find or obsolete electronic components and semiconductors all over the world.

With over two million different components listed you are sure to find the part you need.

Feel free to visit us today at our online store:

LittleDiode.com

Looking forward to providing you with the best possible service.