

# VCR Hi-Fi audio signal REC / PB amplifier with flying-erase oscillator

## BA7745FS

The BA7745FS has the recording and playback amplifiers required for Hi-Fi VCR signal processing, and also contains a flying-erase oscillator. The recording system uses a constant-current amplifier with AGC to eliminate the need to adjust the recording current, and ensure stable operation as the head wears. The IC also features REC MUTE and OVER REC functions .

The playback system has a high-gain preamplifier, a low-offset head switch, a VCA and an EP-gain amplifier. The flying-erase oscillator has low 2nd and 3rd harmonic distortion, and when connected to an external driver large output current can be obtained.

A H / L control system eliminates the need for special power supplies for the recording and playback systems. The IC has low power consumption, and comes in a compact 32-pin SSOP-P package that requires little area on the PCB. It will improve the reliability and performance of your designs while reducing external component requirements.

### ●Applications

VCRs

### ●Features

- The low-noise playback amplifier has a total gain of 83dB (Typ.). Designed for VHS-bandoperation with low external parts count. It has two built-in circuits for Hi-Fi VCR operation.
- 2) The circuit has been designed to suppress head-switching noise.
  - 3) Built-in EP / SP gain switching function that boosts the playback gain by 5dB.
  - 4) Built-in VCA for easy playback output adjustment.
  - 5) High-output recording amplifier for audio FM recording.
  - 6) Constant-current drive provides stable recording characteristics when the load (head impedance) is fluctuating.
  - 7) Built-in recording level AGC eliminates the need to adjust recording current.
  - 8) Built-in low-pass filter limits the input bandwidth of the recording amplifier.
  - 9) Built-in OVER REC recording current amplifier function and REC MUTE function that stops recording output.
  - 10) Built-in high-frequency oscillator for use with flying erase function.
  - 11) Record / playback switching can be done directly via the system controller, and consumes little power.
  - 12) Possible to construct a high-performance audio system by pairing this chip with a Hi-Fi-audio signal processing IC.

●Block diagram

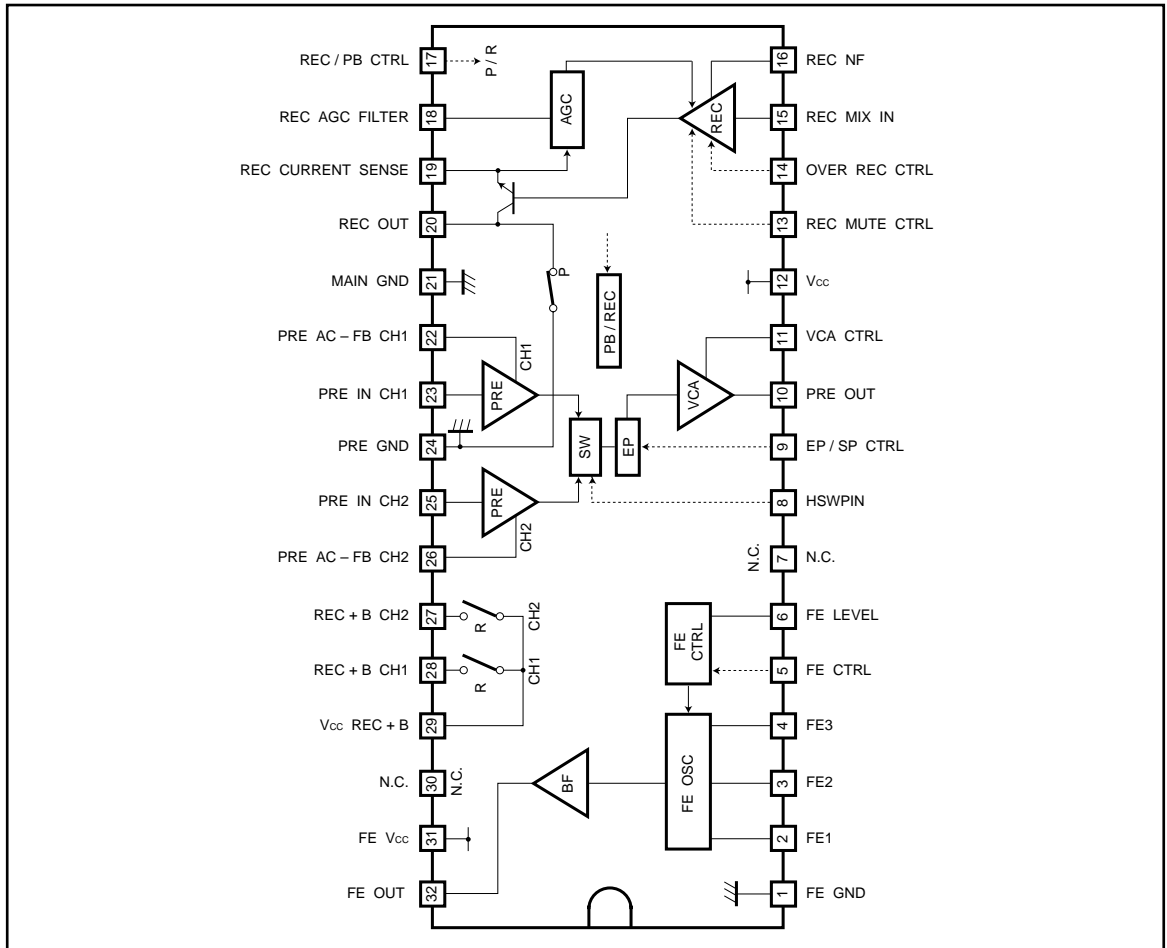

●Absolute maximum ratings (Ta = 25°C)

Parameter	Symbol	Limits		Unit
Power supply voltage	Vcc	PB / REC system	7.0	V
		FE system	12.5	
Power dissipation	Pd	1000*		mW
Operating temperature	Topr	- 10 ~ + 70		°C
Storage temperature	Tstg	- 55 ~ + 125		°C

\* When mounted on a 90mm × 50mm × 1.6mm glass epoxy board, reduced by 10mW for each increase in Ta of 1°C over 25°C.

● Recommended operating conditions (Ta = 25°C)

Parameter		Symbol	Min.	Typ.	Max.	Unit
Recommended operating voltage	PB / REC system	V <sub>CCS</sub>	4.5	5.0	5.5	V
	FE system		10.5	11.0	11.5	V

● Electrical characteristics

Recording system (unless otherwise noted, Ta = 25°C, V<sub>CC</sub> = 5V, and f = 1.7MHz)

Parameter	Symbol	Min.	Typ.	Max.	Unit	Conditions
						17pin: H
Quiescent current	I <sub>q (REC)</sub>	—	66	90	mA	No signal, pin 12 + pin 29, inflow current
Output current AGC level	I <sub>OAR</sub>	44.7	48.2	51.7	mA <sub>P-P</sub>	15pin 93.0dBμIN, 19pin OUT
Output current AGC range	ΔI <sub>OAR</sub>	10	13	—	dB	ΔAGC < 0.8dB, 19pin OUT
Cross modulation distortion 0.4MHz component	CMD <sub>04</sub>	—	-50	-43	dB	15pin MIXIN (*), 19pin OUT (0.4MHz - 1.3MHz)
Cross modulation distortion 0.9MHz component	CMD <sub>09</sub>	—	-55	-40	dB	15pin MIXIN (*), 19pin OUT (0.9MHz - 1.3MHz)
2nd-harmonic distortion 2.6MHz component	2HD <sub>26</sub>	—	-47	-40	dB	15pin MIXIN (*), 19pin OUT (2.6MHz - 1.3MHz)
Cross modulation distortion 3.0MHz component	CMD <sub>30</sub>	—	-42	-35	dB	15pin MIXIN (*), 19pin OUT (3.0MHz - 1.3MHz)
2nd-harmonic distortion 3.4MHz component	2HD <sub>34</sub>	—	-45	-40	dB	15pin MIXIN (*), 19pin OUT (3.4MHz - 1.7MHz)
OVER REC holding voltage	V <sub>14L</sub>	0.0	—	2.2	V	When 14pin DC, NORMAL REC
OVER REC holding voltage	V <sub>14H</sub>	3.5	—	V <sub>CC</sub>	V	When 14pin DC, OVER REC
Current emphasis OVER	I <sub>OR.OV</sub>	+ 1.4	+ 1.9	+ 2.4	dB	15pin 93.0dBμIN, 14pin: "H"
REC MUTE holding voltage	V <sub>13L</sub>	0.0	—	2.2	V	When 13pin DC, MUTE OFF
REC MUTE holding voltage	V <sub>13H</sub>	3.5	—	V <sub>CC</sub>	V	When 13pin DC, MUTE ON
Mute attenuation	I <sub>OR.MU</sub>	—	-45	-40	dB	15pin 93.0dBμIN, 13pin: "H"

\* f = 1.3MHz (89.0dBμ) + 1.7MHz (97.0dBμ) (MIX)

Playback system (unless otherwise noted,  $T_a = 25^\circ\text{C}$ ,  $V_{CC} = 5\text{V}$ , and  $f = 1.5\text{MHz}$ )

Parameter	Symbol	Min.	Typ.	Max.	Unit	Conditions
(Playback mode)						17pin: "L" 11pin: 2.0V
Supply current	$I_{q(PB)}$	—	19.0	31.0	mA	Inflow current to pin 12 when no signal.
Voltage gain CH1	$G_{VP1}$	80	83	86	dB	23pin, 20.5dB $\mu\text{IN}$ , 10pin OUT, 8pin: "H"
Voltage gain CH2	$G_{VP2}$	80	83	86	dB	25pin, 20.5dB $\mu\text{IN}$ , 10pin OUT, 8pin: "L"
Voltage gain differential	$\Delta G_{VP}$	-2.0	0	+2.0	dB	23pin, 25pin, 20.5dB $\mu\text{IN}$ , $\Delta 10\text{pin}$ OUT
CH1 to CH2 crosstalk	$CT_{1\rightarrow 2}$	—	-40	-35	dB	23pin 31.0dB $\mu$ , 25pin 0 IN, 8pin: "H" $\rightarrow$ "L", $\Delta 10\text{pin}$ OUT
CH2 to CH1 crosstalk	$CT_{2\rightarrow 1}$	—	-40	-35	dB	23pin 0, 25pin 31.0dB $\mu\text{IN}$ , 8pin: "H" $\rightarrow$ "L", $\Delta 10\text{pin}$ OUT
CH1 frequency characteristic	$f_{P1}$	0	-2.4	-5	dB	23pin 20.5dB $\mu\text{IN}$ , 8pin: "H" $f = 2.2\text{MHz} / 1.0\text{MHz}$ , $\Delta 10\text{pin}$ OUT
CH2 frequency characteristic	$f_{P2}$	0	-2.4	-5	dB	25pin 20.5dB $\mu\text{IN}$ , 8pin: "L" $f = 2.2\text{MHz} / 1.0\text{MHz}$ , $\Delta 10\text{pin}$ OUT
Gain adjustment headroom	$-\Delta G_{VCA}$	—	-40	-30	dB	11pin 2.0V $\rightarrow$ 3.3V, $\Delta 10\text{pin}$ OUT
Gain adjustment headroom	$+\Delta G_{VCA}$	+4	+6	—	dB	11pin 2.0V $\rightarrow$ 0.8V, $\Delta 10\text{pin}$ OUT
Maximum output voltage	$V_{OMP}$	2.0	2.6	—	$V_{P-P}$	Pin 23 and 25 IN, pin 10 OUT 3rd-harmonic distortion, when -30dB.
CH1 input conversion noise	$V_{NP1}$	—	0.4	1.0	$\mu\text{V}_{rms}$	Input conversion for pin 23: 0.01 $\mu\text{F} + 10\Omega$ at GND Pin 8: "H", pin 10 OUT.
CH2 input conversion noise	$V_{NP2}$	—	0.4	1.0	$\mu\text{V}_{rms}$	Input conversion for pin 25: 0.01 $\mu\text{F} + 10\Omega$ at GND Pin 8: "L", pin 10 OUT.
Head switch voltage	$V_{HS2}$	0.0	—	2.2	V	Pin 8 DC when CH2 operating
Head switch voltage	$V_{HS1}$	2.8	—	$V_{CC}$	V	Pin 8 DC when CH1 operating
Output DC offset	$\Delta V_{ODC}$	-20	0	+20	mV	23, 25pin 0 IN, 8pin: "H" $\rightarrow$ "L", $\Delta 10\text{pin}$ OUT
PB holding voltage	$V_{17L}$	0.0	—	1.0	V	Pin 17 DC for PB mode
REC holding voltage	$V_{17H}$	3.5	—	$V_{CC}$	V	Pin 17 DC for REC mode
Head switch-on resistance	$R_{SWP}$	—	5	10	$\Omega$	Pin 20 ON resistance
SP holding voltage	$V_{9L}$	0.0	—	2.2	V	Pin 9 DC for SP mode
EP holding voltage	$V_{9H}$	3.5	—	$V_{CC}$	V	Pin 9 DC for EP mode
Gain emphasis EP	$G_{VP, EP}$	4.0	5.0	6.0	dB	23, 25pin 20.5dB $\mu\text{IN}$ , 9pin: "H", 10pin OUT

### ●Design reference values

Flying erase system (unless otherwise noted,  $T_a = 25^\circ\text{C}$ ,  $V_{CC} = 11.0\text{V}$ )

Parameter	Symbol	Min.	Typ.	Max.	Unit	Conditions
(Flying erase mode)						5pin: "H"
Supply current	$I_{q(FE)}$	—	12.0	—	mA	Pin 31 inflow current
Pin 2 voltage	$V_2$	—	5.5	—	V	2pin DC
Pin 3 voltage	$V_3$	—	5.5	—	V	3pin DC
Pin 6 voltage	$V_6$	—	1.0	—	V	6pin DC
Pin 32 voltage	$V_{32}$	—	4.3	—	V	32pin DC
Oscillator frequency range	$f_{32}$	8	—	13	MHz	32pin OUT
Output amplitude range	$\upsilon_{32}$	—	2.8	—	$V_{P-P}$	32pin OUT
FE ON holding voltage	$V_{5H}$	4.0	—	$V_{CC}$	V	5pin DC, When FE ON
FE OFF holding voltage	$V_{5L}$	0	—	0.5	V	5pin DC, When FE OFF

\* The values given above are design values, they are not ratings and are not guaranteed.

● Measurement circuit

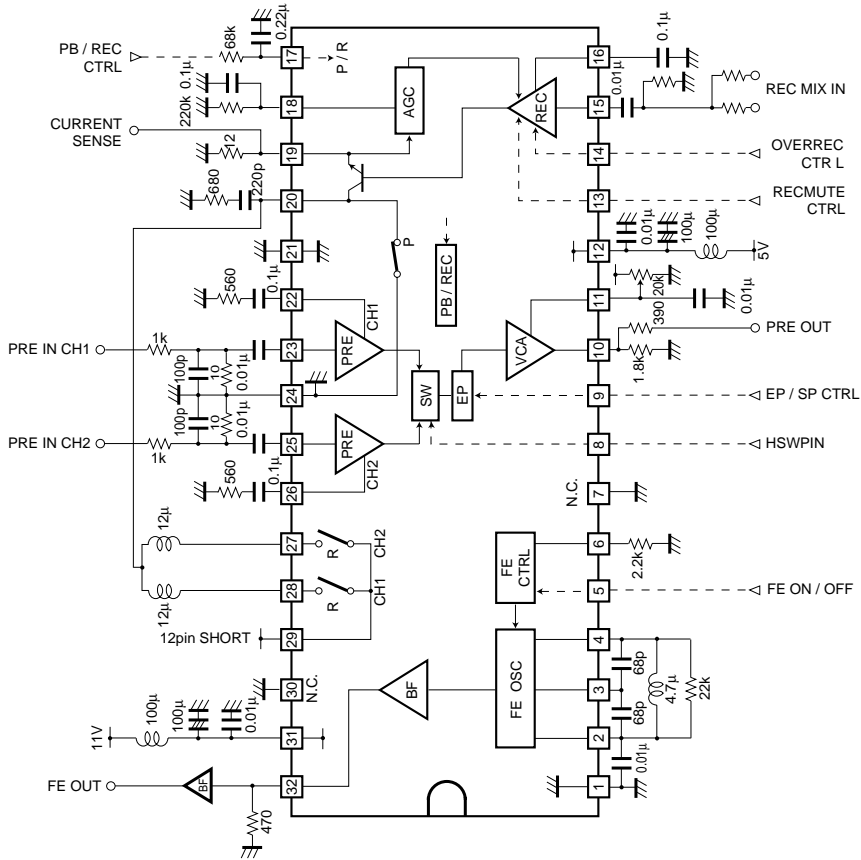

Fig. 1

● Control mode tables

(1) REC / PB control

Switch between REC and PB using pin 17.

Control pin	Mode	Function			
		REC AMP	PRE AMP	REC + B SW	HEAD SW (P)
REC / PB					
H	REC	ON	OFF	ON	OFF
L	PB	OFF	ON	OFF	ON

## (2) OVER REC control

Control for OVER REC (current emphasis) is done using pin 14.

When in OVER REC mode, the gain setting is recording amplifier AGC level + 1.9dB.

Control pin	Mode	Function
OVER REC		REC AGE Level
H	OVER REC	60.0mAP-P
L	—	48.2mAP-P

## (3) REC MUTE control

Control for REC MUTE when recording is done using pin 13.

Control pin	Mode	Function
REC MUTE		REC AMP
H	REC MUTE	OFF
L	—	ON

## (4) EP / SP control

EP / SP control during playback is done using pin 9. When EP is selected, the gain of the playback amplifier is increased by 5dB over its normal setting.

Control pin	Mode	Function
EP / SP		PRE AMP gain
H	EP	Typ. + 5dB
L	SP	Typ.



## ● External dimensions (Units: mm)

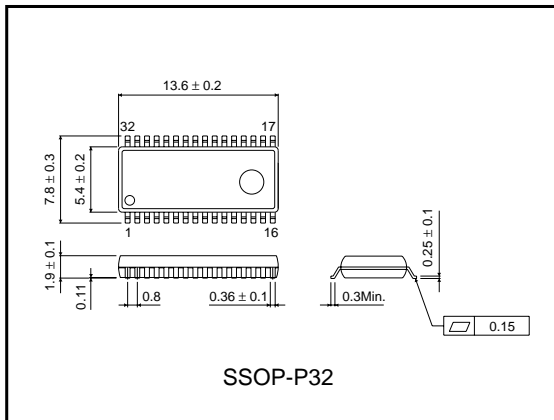



LittleDiode supplies new, hard to find or obsolete electronic components and semiconductors all over the world.

With over two million different components listed you are sure to find the part you need.

Feel free to visit us today at our online store:

[LittleDiode.com](http://LittleDiode.com)

Looking forward to providing you with the best possible service.