

VCR Hi-Fi audio signal REC / PB amplifier

BA7746S / BA7746FS

The BA7746S and BA7746FS contains the recording and playback amplifiers required for Hi-Fi VCR signal processing. The recording system uses a constant-current amplifier with AGC to eliminate the need to adjust the recording current, and ensure stable operation as the head wears. The IC also features REC MUTE and OVER REC functions. The playback system has a high-gain preamplifier, a low- offset head switch, VCA, and an EP-gain amplifier. In addition, all functions operate off a single 5V supply, and a H / L control system eliminates the need for special power supplies for the recording and playback systems. The IC has low power consumption, and comes in a compact 32-pin SSOP-A package that requires little area on the PCB. It will improve the reliability and performance of your designs while reducing external component requirements.

●Applications

VCRs

●Features

- 1) The low-noise playback amplifier has a total gain of 79dB (Typ.). Designed for VHS-band operation with low external parts count. It has two built-in circuits for Hi-Fi VCR operation.
- 2) The circuit has been designed to suppress head-switching noise.
- 3) Built-in EP / SP gain switching function that boosts the playback gain by 5dB.
- 4) Built-in VCA for easy playback output adjustment.
- 5) High-output recording amplifier for audio FM recording.
- 6) Constant-current drive provides stable recording characteristics when the load (head impedance) is fluctuating.
- 7) Built-in recording level AGC eliminates the need to adjust recording current.
- 8) Built-in low-pass filter limits the input bandwidth of the recording amplifier.
- 9) Built-in OVER REC recording current amplifier function and REC MUTE function that stops recording output.
- 10) Low power consumption. Operates off a single 5V power supply.
- 11) Record / playback switching can be done directly via the system controller, and consumes little power.
- 12) Possible to construct a high-performance audio system by pairing this chip with a Hi-Fi-audio signal processing IC.

●Absolute maximum ratings (Ta = 25°C)

Parameter	Symbol	Limits	Unit
Power supply voltage	V _{cc}	7.0	V
Power dissipation	BA7746S	1050*1	mW
	BA7746FS	800*2	mW
Operating temperature	Topr	- 10 ~ + 70	°C
Storage temperature	Tstg	- 55 ~ + 125	°C

*1 When mounted on a 90mm × 50mm × 1.6mm glass epoxy board, reduced by 10.5mW for each increase in Ta of 1°C over 25°C.

*2 When mounted on a 90mm × 50mm × 1.6mm glass epoxy board, reduced by 8mW for each increase in Ta of 1°C over 25°C.

●Recommended operating conditions (Ta = 25°C)

Parameter	Symbol	Min.	Typ.	Max.	Unit
Operating voltage	V _{CCS}	4.5	5.0	5.5	V

●Block diagram

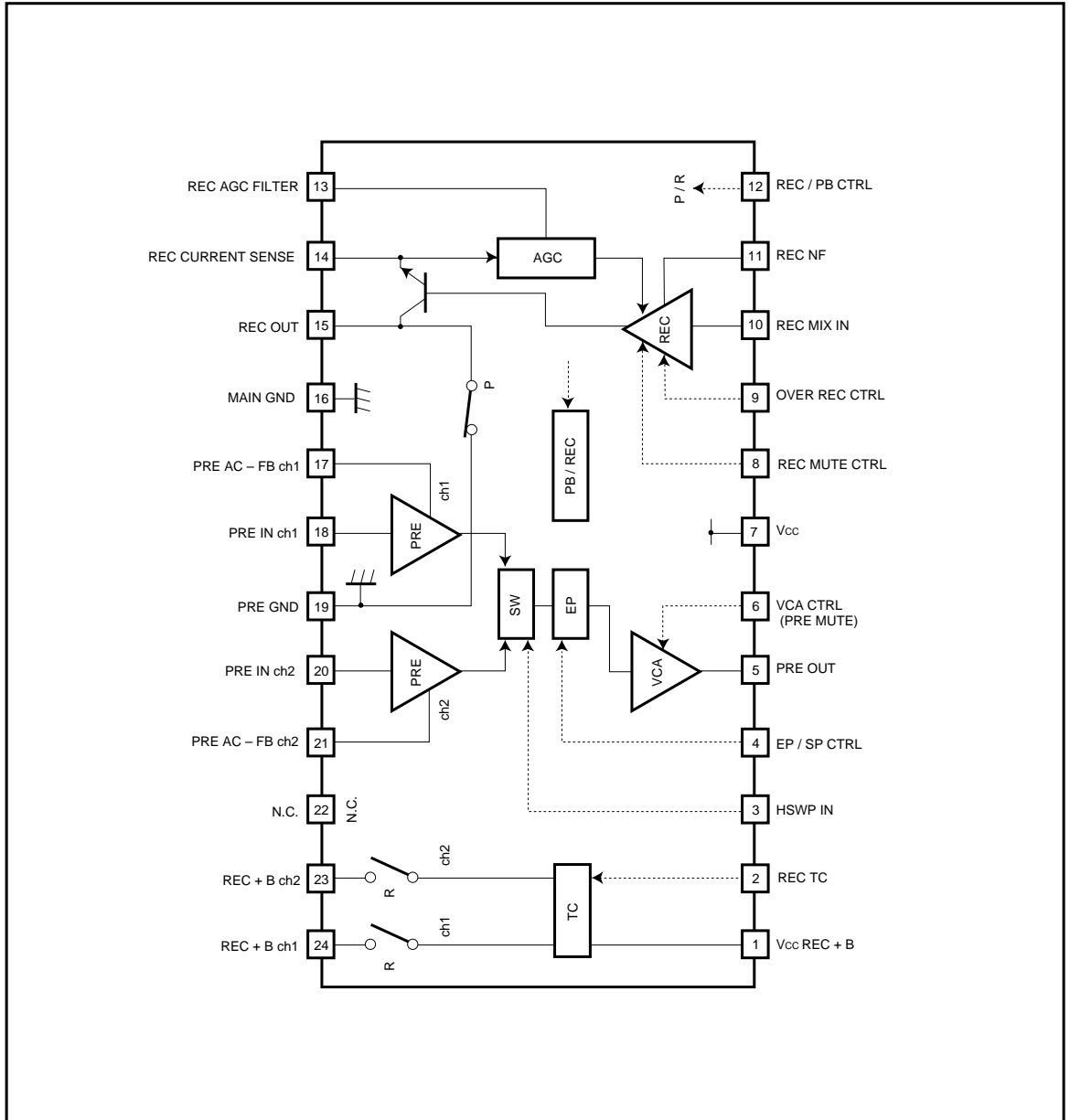

● Pin descriptions

Pin No.	Pin name, function and remarks	Voltage	Circuit diagram
1	<p>⟨V_{CC} REC + B⟩</p> <ul style="list-style-type: none"> • Power supply for REC + B. • Connect to V_{CC} (pin 7). 	V _{CC}	—
2	<p>⟨REC TC⟩</p> <ul style="list-style-type: none"> • REC + B time constant. • Use to adjust the REC + B rise time using the C value. The value of the built-in resistor is 20kΩ. • The effect of current spikes when recording is started is reduced 	REC: 0.9V PB: 0V	
3	<p>⟨HSWP IN⟩</p> <ul style="list-style-type: none"> • Pulse input for head switching. • ch1: H, ch2: L 	—	
4	<p>⟨EP / SP CTRL⟩</p> <ul style="list-style-type: none"> • EP / SP mode control. • In EP mode, the playback amplifier gain is set to +5dB (Typ.). • EP: H, SP: L • Do not leave open circuit 	—	
5	<p>⟨PRE OUT⟩</p> <ul style="list-style-type: none"> • Playback amplifier output. • Open emitter output. • When there is a chance of oscillation due to capacitive load, reduce the output current, or connect a resistor in series (approx. 390Ω). • Avoid capacitive coupling with the playback input 	REC: 3.6V PB: 1.9V (RL: 1.8kΩ)	
6	<p>⟨VCA CTRL (PRE MUTE)⟩</p> <ul style="list-style-type: none"> • VCA control. • When the terminal is open (a C is required), the playback amplifier gain is set to the Typ. value. • The PRE MUTE function is made possible by connection of a mute H signal to this through a diode 	REC: 2.0V PB: 2.0V	

Pin No.	Pin name, function and remarks	Voltage	Circuit diagram
7	<p>(Vcc)</p> <ul style="list-style-type: none"> Power supply for anything other than REC + B. 	Vcc	—
8	<p>(REC MUTE CTRL)</p> <ul style="list-style-type: none"> REC MUTE control. In REC MUTE mode, the recording amplifier output is stopped. REC: L, REC MUTE: H. Do not leave open circuit. 	—	
9	<p>(OVER REC CTRL)</p> <ul style="list-style-type: none"> OVER REC control. In OVER REC mode, the recording current is set to + 2dB (Typ.). Do not leave open circuit. 	—	
10	<p>(REC MIX IN)</p> <ul style="list-style-type: none"> Recording amplifier input. 	REC: 2.9V PB: 2.9V	
11	<p>(REC NF)</p> <ul style="list-style-type: none"> Recording amplifier feedback. Connect the GND of a decoupling capacitor to main GND (pin 16) to improve common-mode distortion. 	REC: 1.4V PB: 0.5V	
12	<p>(REC / PB CTRL)</p> <ul style="list-style-type: none"> REC / PB control pin. Use of an RC circuit time constant to slow the rise of the control signal reduces noise spikes during switching. Do not leave open circuit. 	—	

Pin No.	Pin name, function and remarks	Voltage	Circuit diagram
13	<p><REC AGC FILTER></p> <ul style="list-style-type: none"> REC AGC filter. The attack characteristics of the recording amplifier can be adjusted using the CR circuit. Reduce the CR circuit GND-side impedance to improve the common-mode distortion. 	REC: 0V PB: 0V	
14	<p><REC CURRENT SENSE></p> <ul style="list-style-type: none"> Terminal for monitoring the recording current. Open emitter output. The REC AGC output current can be adjusted with the R value. <p>e.g. 12Ω...48.2mA_{P-P}, 15Ω...38.6mA_{P-P}</p>	REC: 0.58V PB: 0V	
15	<p><REC OUT></p> <ul style="list-style-type: none"> Recording amplifier output and head switch. Open collector output. The head switch turns on and off in accordance with the REC / PB control signal 	REC: 4.1V PB: 0V	
16	<p><MAIN GND></p> <ul style="list-style-type: none"> Earth for circuits other than the preamplifier. Reference potential for the IC 	GND	—
17	<p><PRE AC-FB ch1></p> <ul style="list-style-type: none"> AC feedback terminal for the playback amplifier (ch1). The high-frequency characteristics of the playback amplifier can be adjusted with the R value 	REC: 0V PB: 0.8V	
18	<p><PRE IN ch1></p> <ul style="list-style-type: none"> Input terminal for the playback amplifier (ch1). The low-frequency cutoff characteristics can be adjusted with the value of the input coupling capacitor. The frequency characteristics can be adjusted so that it is flat with the L value of the rotary transformer, and the external capacitor C (100pF etc.). 	REC: 0V PB: 0.7V	

Pin No.	Pin name, function and remarks	Voltage	Circuit diagram
19	<p>⟨PRE GND⟩</p> <ul style="list-style-type: none"> • GND for the HEAD AMP. • Use this terminal for the pin 17 to pin 21 GND connections to improve the noise characteristics. • Connect this pin to the main GND (pin 16). 	GND	—
20	<p>⟨PRE IN ch2⟩</p> <ul style="list-style-type: none"> • Input for the playback amplifier (ch2). The low-frequency cutoff characteristics can be adjusted with the value of the input coupling capacitor. • The frequency characteristics can be adjusted so that it is flat with the L value of the rotary transformer, and the external capacitor C (100pF etc.). 	REC: 0V PB: 0.7V	
21	<p>⟨PRE AC-FB ch2⟩</p> <ul style="list-style-type: none"> • AC feedback for the playback amplifier (ch2). • The high-frequency characteristics of the playback amplifier can be adjusted with the R value. 	REC: 0V PB: 0.8V	
22	<p>⟨N.C.⟩</p> <ul style="list-style-type: none"> • Unused. • Connect to ⟨MAIN GND⟩ to improve the interchannel matching. 	—	—
23	<p>⟨REC + B ch2⟩</p> <ul style="list-style-type: none"> • REC + B (ch2). • Open emitter output circuit. • Turns on and off in accordance with the REC / PB control signal. 	REC: 4.1V PB: 0V	
24	<p>⟨REC + B ch1⟩</p> <ul style="list-style-type: none"> • REC + B (ch1). • Open emitter output circuit. • Turns on and off in accordance with the REC / PB control signal. 	REC: 4.1V PB: 0V	

* The values given above are design values, they are not ratings and are not guaranteed.

●Electrical characteristics

Recording mode (pin 12→ "H") (unless otherwise noted, Ta = 25°C, Vcc = 5.0V, and f = 1.7MHz)

Parameter	Symbol	Min.	Typ.	Max.	Unit	Conditions
Quiescent current	I _{q (REC)}	—	66	90	mA	No signal, pin 1 + pin 7, inflow current
Output current AGC level	I _{OAR}	44.2	48.2	52.2	mA _{P-P}	10pin 93.0dBμIN, 14pin OUT
Output current AGC level	ΔI _{OAR}	10	13	—	dB	ΔAGC < 0.8dB, 14pin OUT
Cross modulation distortion 0.4MHz component	CMD ₀₄	—	-50	-40	dB	10pin MIXIN*, 14pin OUT (0.4MHz - 1.3MHz)
Cross modulation distortion 0.9MHz component	CMD ₀₉	—	-55	-40	dB	10pin MIXIN*, 14pin OUT (0.9MHz - 1.3MHz)
OVER REC holding voltage	V _{9L}	0.0	—	2.2	V	9pin DC, When NORMAL REC
OVER REC holding voltage	V _{9H}	3.5	—	V _{CC}	V	9pin DC, When OVER REC
Current emphasis OVER	I _{OR.OV}	1.4	1.9	2.4	dB	10pin 93.0dBμIN, 9pin: "H"
REC MUTE holding voltage	V _{8L}	0.0	—	2.2	V	8pin DC, When MUTE OFF
REC MUTE holding voltage	V _{8H}	3.5	—	V _{CC}	V	8pin DC, When MUTE ON
Mute attenuation	I _{OR.MU}	—	-50	-40	dB	10pin 93.0dBμIN, 8pin: "H"

* f = 1.3MHz (87.0dBμ) + 1.7MHz (95.0dBμ) (MIX)

Playback mode (pin 12→ "L") (unless otherwise noted, Ta = 25°C, Vcc = 5.0V, and f = 1.5MHz)

Parameter	Symbol	Min.	Typ.	Max.	Unit	Conditions
Supply current	I _{q (PB)}	—	19	31	mA	Inflow current to pin 7 when no signal.
Voltage gain CH1	G _{VP1}	75	79	83	dB	18pin, 20.5dBμIN, 5pin OUT, 3pin: "H"
Voltage gain CH2	G _{VP2}	75	79	83	dB	20pin, 20.5dBμIN, 5pin OUT, 3pin: "L"
Voltage gain differential	ΔG _{VP}	-2.0	0	2.0	dB	18pin, 20pin, 20.5dBμ, Δ5pin OUT
CH1 to CH2 crosstalk	CT _{1→2}	—	-45	-35	dB	18pin 31.0dBμ, 20pin 0 IN, 3pin: "H"→ "L", Δ5pin OUT
CH2 to CH1 crosstalk	CT _{2→1}	—	-45	-35	dB	18pin 0, 20pin 31.0dBμIN, 3pin: "L"→ "H", Δ5pin OUT
CH1 frequency characteristic	f _{P1}	0	-2.4	-5	dB	18pin 20.5dBμIN, 3pin: "H" f = 2.2MHz / 1.0MHz, Δ5pin OUT
CH2 frequency characteristic	f _{P2}	0	-2.4	-5	dB	20pin 20.5dBμ IN, 3pin: "L" f = 2.2MHz / 1.0MHz, Δ5pin OUT
Gain adjustment headroom	- ΔG _{VCA}	—	-50	-35	dB	6pin 3.2V, Δ5pin OUT
Gain adjustment headroom	+ ΔG _{VCA}	4	6	—	dB	6pin 0.8V, Δ5pin OUT
Maximum output voltage	V _{OMP}	2.0	2.6	—	V _{P-P}	Pin 18 and 20 IN, pin 5 OUT 3rd-harmonic distortion, when-30dB.
CH1 input conversion noise	V _{NP1}	—	0.4	1.0	μV _{rms}	Input conversion for pin 18: 0.01μ F + 10Ω at GND Pin 3: "H", pin 5 OUT.
CH2 input conversion noise	V _{NP2}	—	0.4	1.0	μV _{rms}	Input conversion for pin 20: 0.01μ F + 10Ω at GND Pin 3: "L", pin 5 OUT.

●Electrical characteristics

Playback mode (pin 12→ "L") (unless otherwise noted, Ta = 25°C, Vcc = 5.0V, and f = 1.5MHz)

Parameter	Symbol	Min.	Typ.	Max.	Unit	Conditions
Head switching voltage	V _{HS2}	0.0	—	2.2	V	Pin 3 DC when ch2 operating
Head switching voltage	V _{HS1}	2.8	—	V _{CC}	V	Pin 3 DC when ch1 operating
Output DC offset	ΔV _{ODC}	- 20	0	20	mV	18, 20pin 0 IN, 3pin "H"→ "L" Δ5pin OUT
PB holding voltage	V _{12L}	0.0	—	1.0	V	Pin 12 DC for PB mode
REC holding voltage	V _{12H}	3.5	—	V _{CC}	V	Pin 12 DC for REC mode
Head switch ON resistance	R _{SWP}	—	5	10	Ω	Pin 15 ON resistance
SP holding voltage	V _{4L}	0.0	—	2.2	V	Pin 4 DC for SP mode
EP holding voltage	V _{4H}	3.5	—	V _{CC}	V	Pin 4 DC for EP mode
Gain emphasis EP	G _{VP.EP}	4.0	5.0	6.0	dB	18, 20pin 20.5dBμIN, 4pin: "H", 5pin OUT

●Measurement circuit

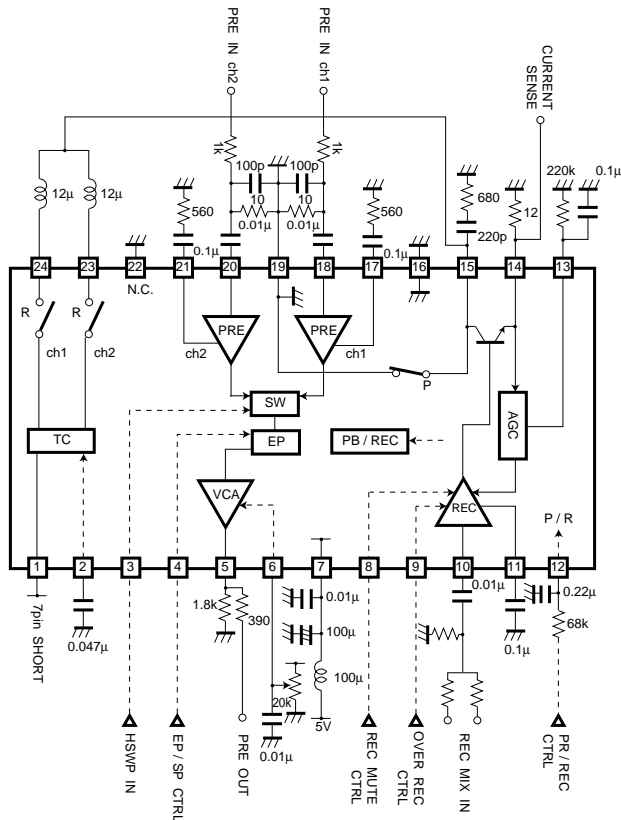

Fig. 1

●Control mode tables

(1) REC / PB control

Switch between REC and PB using pin 12.

Control pin REC / PB	Mode	Function			
		REC AMP	PRE AMP	REC + B SW	HEAD SW (P)
H	REC	ON	OFF	ON	OFF
L	PB	OFF	ON	OFF	ON

(2) OVER REC control

Control for OVER REC (current emphasis) is done using pin 9.

When in OVER REC mode, the gain setting is recording amplifier AGC level + 1.9dB.

Control pin OVER REC	Mode	Function
		REC AGC Level
H	OVER REC	60.0mA _{P-P}
L	—	48.2mA _{P-P}

(3) REC MUTE control

Control for REC MUTE when recording is done using pin 8.

Control pin REC MUTE	Mode	Function
		REC AMP
H	REC MUTE	OFF
L	—	ON

(4) EP / SP control

EP / SP control during playback is done using pin 4. When

EP is selected, the gain of the playback amplifier is increased by 5dB over its normal setting.

Control pin EP / SP	Mode	Function
		PRE AMP gain
H	EP	Typ. + 5dB
L	SP	Typ.

● Application example

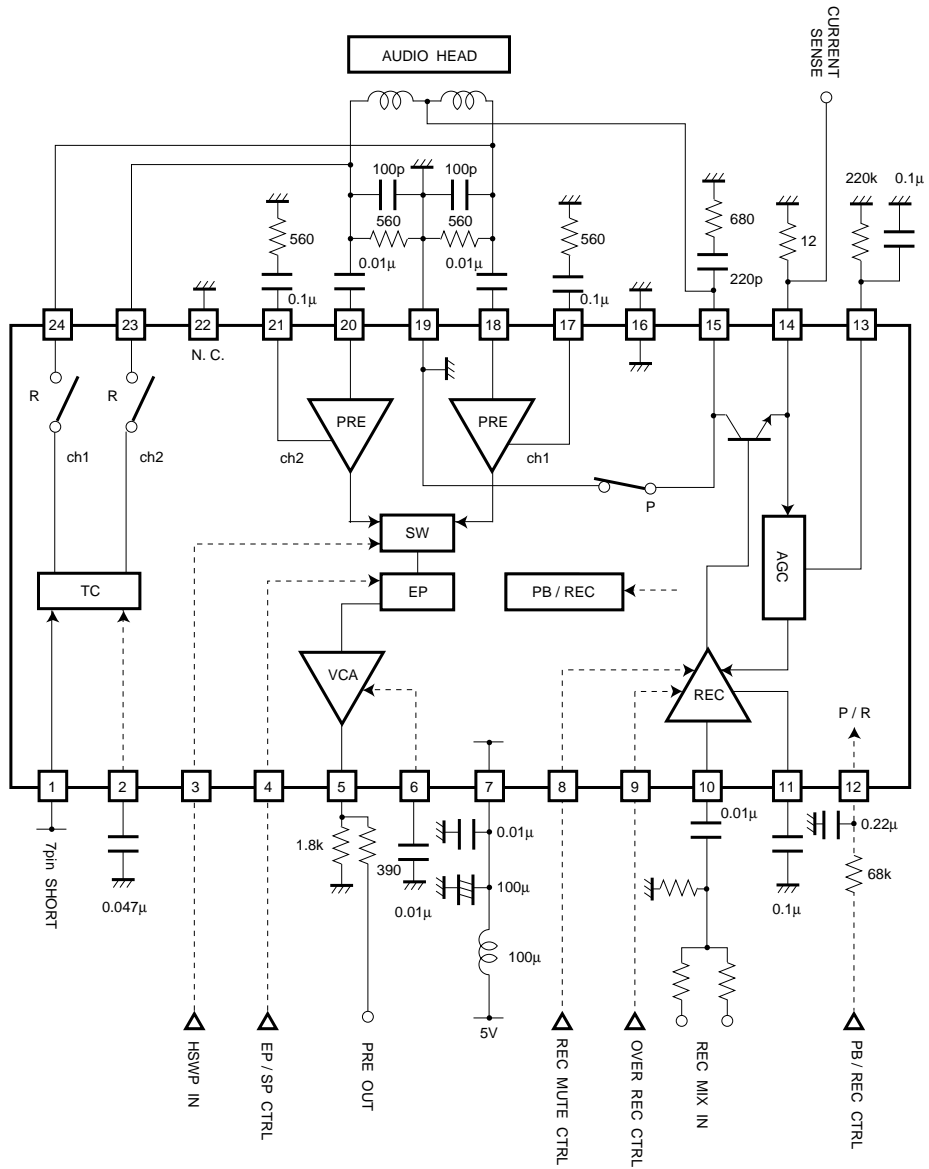

Fig. 2

●Operation notes

(1) preamplifier

The preamplifier in this IC is a high-gain amplifier for FM audio. This amplifier has been carefully designed for stability. However, the design of the PCB greatly effects the stability of the preamplifier. A list of general precautions are given below. Take note when designing the PCB.

- 1)The oscillation margin is reduced when the input and output patterns are physically close. The input and output wiring should not come out of the same side of the IC.

Good example

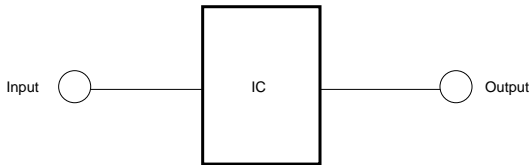

Bad example

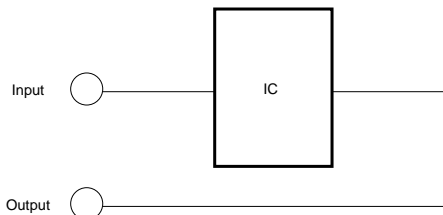

- 2)The GND pattern should be connected at one point to the main IC GND (pin 16). In addition, the preamplifier input-side GND and output-side GND should be as close as possible to the main IC GND.

Good example

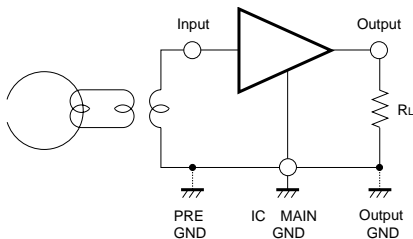

Bad example

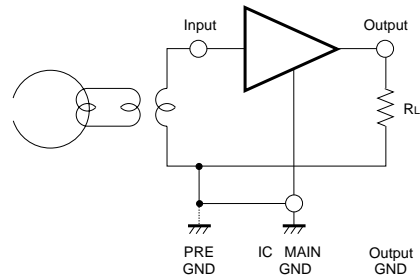

- 3)A large GND pattern under the IC has a shielding effect, and reduced the chance of picking up external noise.

- 4)When the preamplifier is connected to a capacitive load such as shielded wire, or when the output current is large, the output may oscillate. In this case, connect a resistor to the preamplifier output (approx. 390Ω).

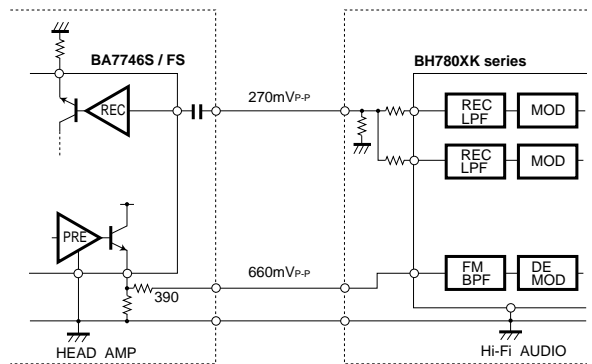

Connection example for BA7746S / BA7746FS and BH780XK series.

(2) REC amplifier

The REC amplifier in this IC is for FM audio. Take note of the following points in order to maintain its common-mode distortion characteristics.

1) Connect the REC AGC FILTER (pin 13) and CURRENT SENSE (pin 14) to the main GND of the IC (pin 16) using leads that are as short as possible.

2) REC NF (pin 11) should be as close to the main IC GND as possible.

3) If you connect a resistor to pin 23 or between pins 24 and 15 to monitor the recording current, the resulting voltage drop may cause the IC to function incorrectly. Use the current sense pin (pin 14) to monitor the recording current.

● External dimensions (Units: mm)

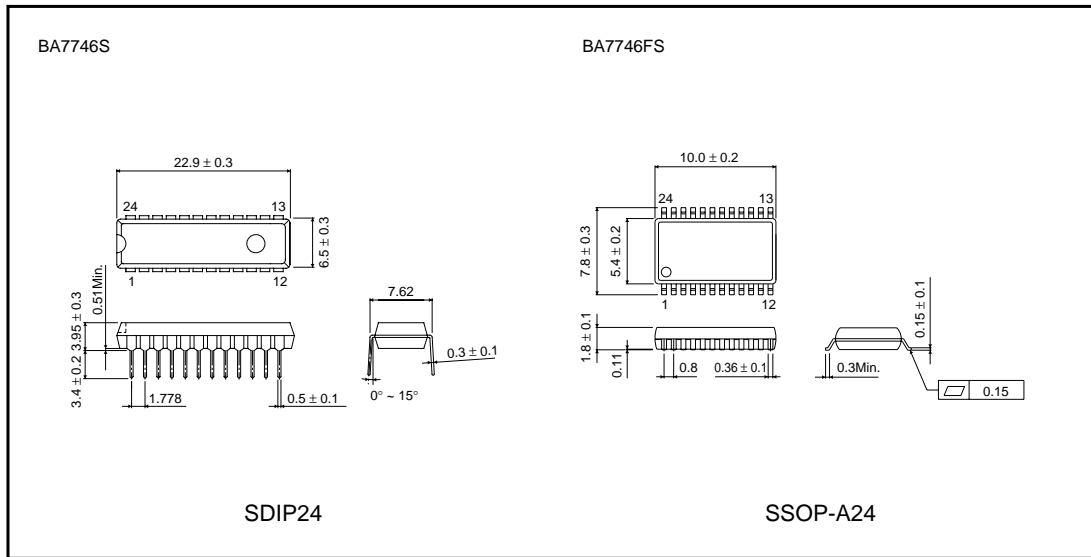

This datasheet has been downloaded from:

www.DatasheetCatalog.com

Datasheets for electronic components.



LittleDiode supplies new, hard to find or obsolete electronic components and semiconductors all over the world.

With over two million different components listed you are sure to find the part you need.

Feel free to visit us today at our online store:

LittleDiode.com

Looking forward to providing you with the best possible service.