

Audio signal processor for mini-component systems

BA7762AFS

The BA7762AFS is an audio signal processor IC for mini-component systems, and includes a recording equalizer, playback equalizer, and input switches.

●Applications

Mini-component systems

●Features

- 1) Dual circuits (for stereo use)
- 2) Chrome tape compatible (switchable EQ characteristics).
- 3) Input switches on chip (TAPE/AUX).
- 4) Compact SSOP-A32 package.

●Absolute maximum ratings (Ta = 25°C)

Parameter	Symbol	Limits	Unit
Applied voltage	V _{CC}	12.5	V
Power dissipation	P _d	800*	mW
Operating temperature	T _{opr}	-25~+75	°C
Storage temperature	T _{stg}	-55~+125	°C

* Reduced by 8.0mW for each increase in Ta of 1°C over 25°C.

●Recommended operating conditions (Ta = 25°C)

Parameter	Symbol	Limits	Unit
Power supply voltage	V _{CC}	9.5~12	V

● Block diagram

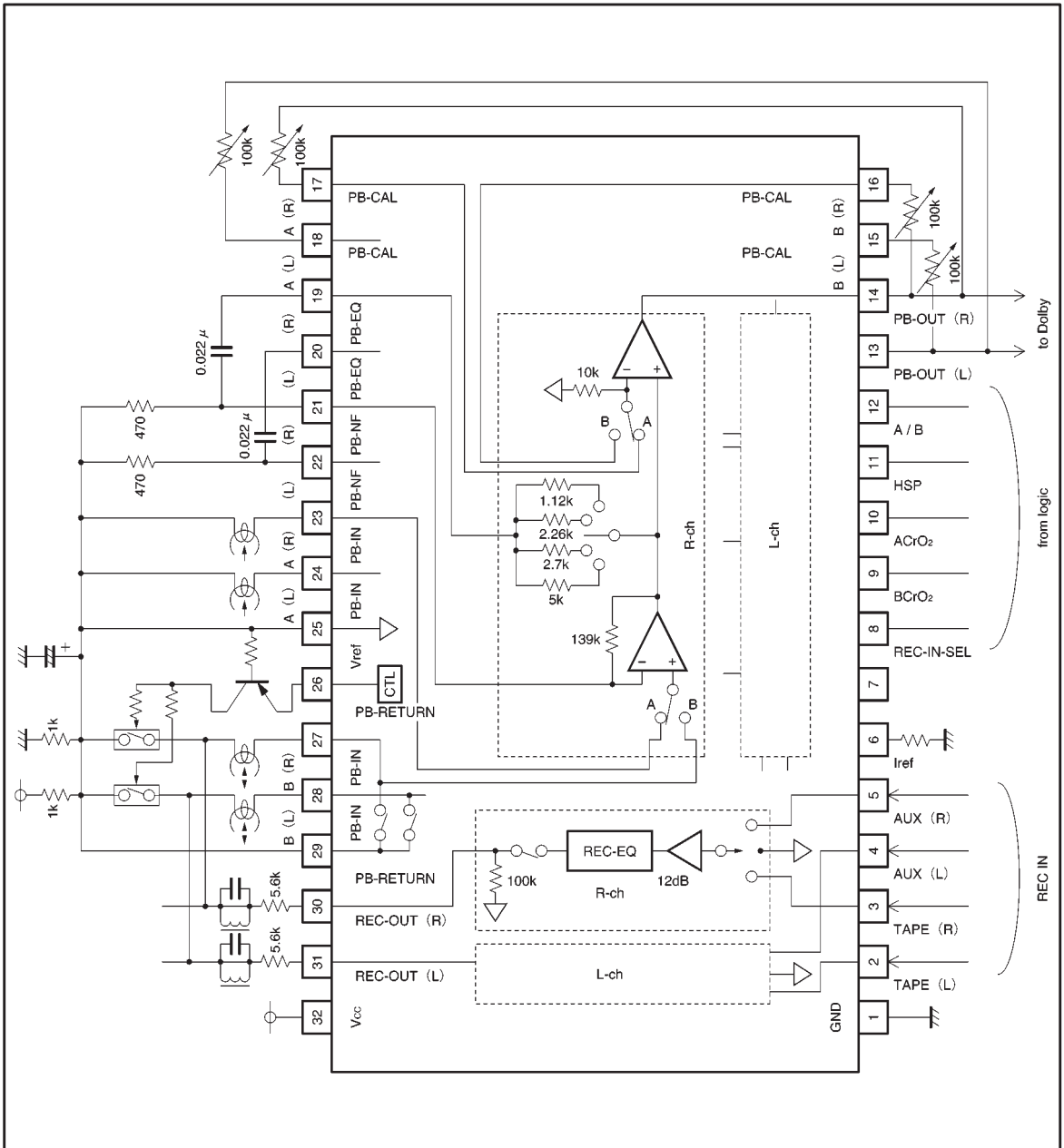

● Pin descriptions

Pin No.	Pin name	Pin voltage	Equivalent circuit	Function
1	GND	—	—	GND
2 3 4 5	TAPE (L) TAPE (R) AUX (L) AUX (R)	$V=V_{ref}$		REC EQ input
6	Iref	$V=1.3V$		Equalizer reference current input
8	REC SEL	$V=2.5V$		Mode control input
9 10	Bcr Acr	—		Mode control input
11	HSP	—		Mode control input

Pin No.	Pin name	Pin voltage	Equivalent circuit	Function
12	A / B	—		Mode control input
13 14	PBOUT (L) PBOUT (R)	V=Vref		PB output
15 16 17 18	PB Cal B (L) PB Cal B (R) PB Cal A (L) PB Cal A (R)	V=Vref		Feedback input
19 20	PB EQ (R) PB EQ (L)	V=Vref		PB-EQ output
21 22	PB NF (L) PB NF (R)	V=Vref		PB-EQ feedback input

Pin No.	Pin name	Pin voltage	Equivalent circuit	Function
23 24	PBOUT (L) PBOUT (R)	$V=V_{ref}$		PB A Deck input
25	Vref	$V=V_{ref}$		Reference
26	PB RETURN	A : $V=V_{ref}$ B : $V=V_{ref}$		Pin that outputs $V_{ref} + 3V$ when Bin Active

Pin No.	Pin name	Pin voltage	Equivalent circuit	Function
27	PB IN B (R)	V=Vref		PB B Deck input
28	PB IN B (L)			REC Return
29	REC RETURN			—
30 31	RECOUT (R) RECOUT (L)	V=Vref		PEC-EQ output
32	Vcc	—	—	Vcc

- Electrical characteristics (unless otherwise noted, $T_a = 25^\circ\text{C}$, $V_{CC} = 10.5\text{V}$, $V_{ref} = 5.25\text{V}$, PB-EQ standard DC gain 55.9dB (R_9, R_{10}, R_{18} , and $R_{19} = 11.0\text{k}\Omega$))

Parameter	Symbol	Min.	Typ.	Max.	Unit	Conditions
Quiescent current	I_Q	8	15	22	mA	No signal
Logic threshold	V_{IL}	0	—	1.0	V	—
	V_{IM}	2.0	—	3.0	V	—
	V_{IH}	4.0	—	V_{CC}	V	—
PB-REC crosstalk	CT PB / REC (1)	—	-80	-60	dBV	$f_{IN}=1\text{kHz}$, $V_{IN}=400\text{mVrms}^{*1}$ REC · EQ → PB · EQ
	CT PB / REC (2)	—	-70	-50	dBV	$f_{IN}=1\text{kHz}$, $V_{IN}=24\text{mVrms}^{*1}$ PB · EQ → REC · EQ
PB-EQ gain	GV PB (1)	29.0	32.0	35.0	dB	$f_{IN}=1\text{kHz}$, $V_{IN}=0.6\text{mVrms}$
	GV PB (2)	25.0	28.0	31.0	dB	$f_{IN}=10\text{kHz}$, $V_{IN}=0.6\text{mVrms}$
	GV PB (3)	20.8	23.8	26.8	dB	$f_{IN}=10\text{kHz}$, $V_{IN}=0.6\text{mVrms}$
	GV PB (4)	19.4	22.4	25.4	dB	$f_{IN}=20\text{kHz}$, $V_{IN}=0.6\text{mVrms}$
	GV PB (5)	14.8	17.8	20.8	dB	$f_{IN}=20\text{kHz}$, $V_{IN}=0.6\text{mVrms}$
PB-EQ maximum output	$V_{omax PB}$	0.3	2.0	—	Vrms	$f_{IN}=1\text{kHz}$, THD=1%
PB-EQ THD	THD PB	—	0.1	0.5	%	$f_{IN}=1\text{kHz}$, $V_{IN}=0.6\text{mVrms}$
PB-EQ noise	$V_N PB$	—	30	70	μVrms	$R_g=820\Omega^{*1}$
PB-EQ channel separation	CT R / L(1)	—	-70	-50	dBV	$f_{IN}=1\text{kHz}$, $V_{IN}=24\text{mVrms}^{*1}$
PB-EQ crosstalk	CT A / B	—	-75	-55	dBV	$f_{IN}=1\text{kHz}$, $V_{IN}=24\text{mVrms}^{*1}$

*1 DIN AUDIO

(unless otherwise noted, $T_a = 25^\circ\text{C}$, $V_{CC} = 10.5\text{V}$, and $V_{ref} = 5.25\text{V}$)

Parameter	Symbol	Min.	Typ.	Max.	Unit	Conditions
REC EQ frequency characteristics	GV REC NN1	6.3	8.3	9.8	dB	$f_{IN}=1\text{kHz}$, $V_{IN}=10\text{mVrms}$
	GV REC NN2	9.3	11.3	13.3	dB	$f_{IN}=5\text{kHz}$, $V_{IN}=10\text{mVrms}$
	GV REC NN3	16.3	19.3	22.3	dB	$f_{IN}=10\text{kHz}$, $V_{IN}=10\text{mVrms}$
REC EQ frequency characteristics	GV REC NC1	9.7	11.2	12.7	dB	$f_{IN}=1\text{kHz}$, $V_{IN}=10\text{mVrms}$
	GV REC NC2	14.5	16.5	18.5	dB	$f_{IN}=5\text{kHz}$, $V_{IN}=10\text{mVrms}$
	GV REC NC3	20.7	23.7	26.7	dB	$f_{IN}=10\text{kHz}$, $V_{IN}=10\text{mVrms}$
REC EQ frequency characteristics	GV REC HN1	7.1	8.6	10.1	dB	$f_{IN}=2\text{kHz}$, $V_{IN}=10\text{mVrms}$
	GV REC HN2	11.2	13.2	15.2	dB	$f_{IN}=10\text{kHz}$, $V_{IN}=10\text{mVrms}$
	GV REC HN3	17.8	20.8	23.8	dB	$f_{IN}=20\text{kHz}$, $V_{IN}=10\text{mVrms}$
REC EQ frequency characteristics	GV REC HC1	11.2	12.7	14.2	dB	$f_{IN}=2\text{kHz}$, $V_{IN}=10\text{mVrms}$
	GV REC HC2	16.1	18.1	20.1	dB	$f_{IN}=10\text{kHz}$, $V_{IN}=10\text{mVrms}$
	GV REC HC3	23.1	26.1	29.1	dB	$f_{IN}=20\text{kHz}$, $V_{IN}=10\text{mVrms}$
REC-EQ channel separation	CT R / L (2)	—	-70	-50	dBV	$f_{IN}=1\text{kHz}$, $V_{IN}=400\text{mVrms}^{*1}$
REC-EQ crosstalk	CT Tape / AUX	—	-70	-50	dBV	$f_{IN}=1\text{kHz}$, $V_{IN}=400\text{mVrms}^{*1}$
REC MUTE attenuation	R MUTE ATT	—	-70	-50	dBV	$f_{IN}=1\text{kHz}$, $V_{IN}=400\text{mVrms}^{*1}$
REC-EQ maximum output	Vomax REC	1.2	1.8	—	Vrms	$f_{IN}=1\text{kHz}$, THD=1%
REC EQ THD	THD REC	—	0.35	0.7	%	$f_{IN}=1\text{kHz}$, $V_{IN}=100\text{mVrms}$
REC EQ S / N	S / N REC	—	-69	-60	dBV	$R_g=5.1\ \Omega$, IHF A

©Not designed for radiation resistance.

*1 DIN AUDIO

● Measurement circuit

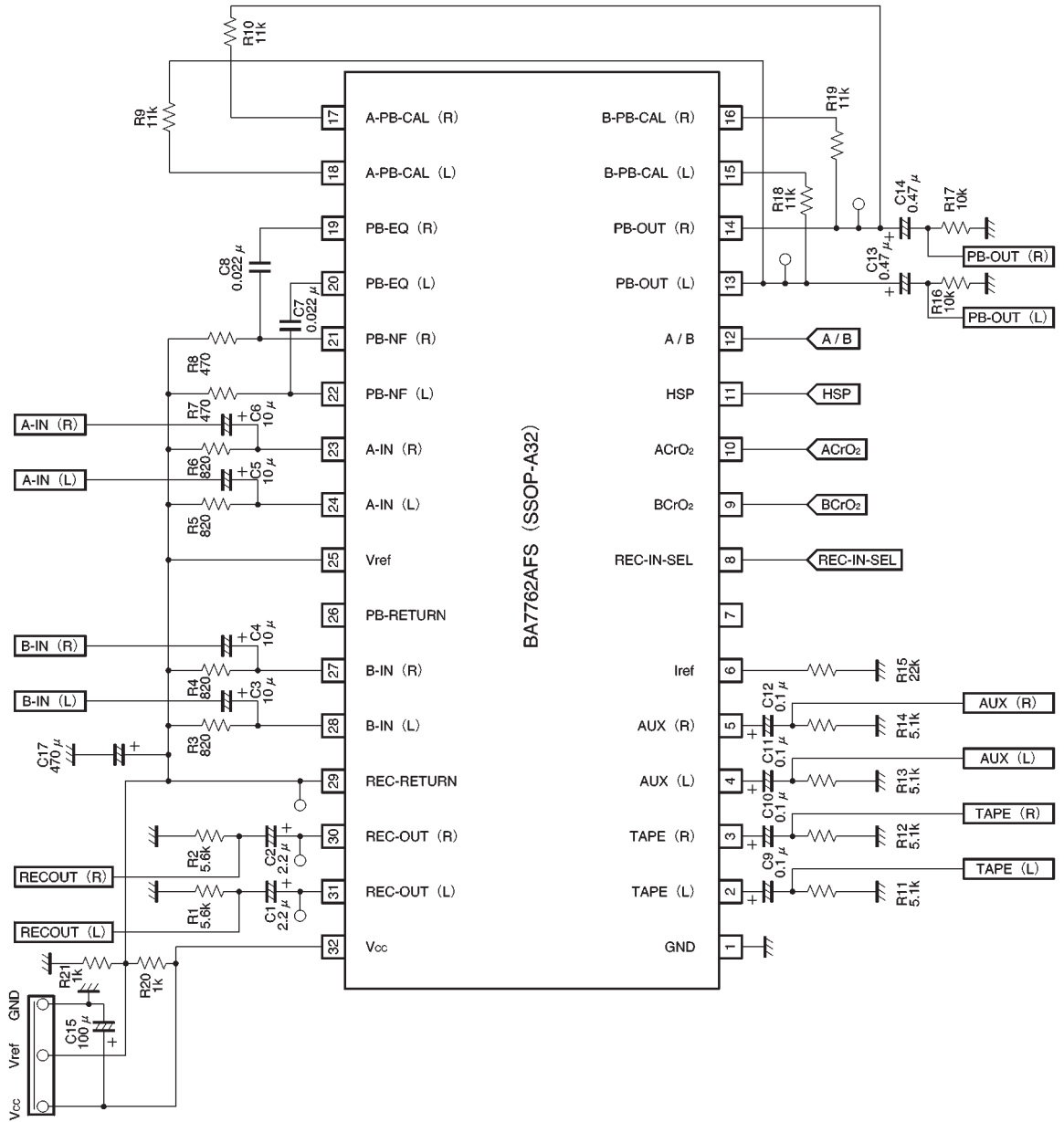

Fig.1

● Measurement circuit conditions

Parameter	Pin No.	Control voltage				
		A/B	REC-IN-SEL	A CrC ₂	B CrC ₂	HSP
Quiescent current	I _Q	L	L	L	L	L
Logic threshold	V _{IL}	—	—	—	—	—
	V _{IM}	—	—	—	—	—
	V _{IH}	—	—	—	—	—
PB-REC crosstalk	CT PB / REC (1)	L	L / H	L	L	L
	CT PB / REC (2)	L / H	L	L	L	L
PB-EQ gain	GV PB (1)	L / H	L	L	L	L
	GV PB (2)	L / H	L	L	L	L
	GV PB (3)	L / H	L	H	H	L
	GV PB (4)	L / H	L	L	L	H
	GV PB (5)	L / H	L	H	H	H
PB-EQ maximum output	Vomax PB	L / H	L	L	L	L
PB-EQ THD	THD PB	L / H	L	L	L	L
PB-EQ noise	VN PB	L / H	L	L	L	L
PB-EQ channel separation	CT R / L (1)	L / H	L	L	L	L
PB-EQ crosstalk	CT A / B	L / H	L	L	L	L
REC EQ frequency characteristics	GV REC NN1	L	L / H	L	L	L
	GV REC NN2	L	L / H	L	L	L
	GV REC NN3	L	L / H	L	L	L
REC EQ frequency characteristics	GV REC NC1	L	L / H	L	H	L
	GV REC NC2	L	L / H	L	H	L
	GV REC NC3	L	L / H	L	H	L
REC EQ frequency characteristics	GV REC HN1	L	L / H	L	L	H
	GV REC HN2	L	L / H	L	L	H
	GV REC HN3	L	L / H	L	L	H
REC EQ frequency characteristics	GV REC HC1	L	L / H	L	H	H
	GV REC HC2	L	L / H	L	H	H
	GV REC HC3	L	L / H	L	H	H
REC-EQ channel separation	CT R / L (2)	L	L / H	L	L	L
REC-EQ crosstalk	CT Tape / AUX	L	L / H	L	L	L
REC MUTE attenuation	R MUTE ATT	L	M	L	L	L
REC EQ maximum output	Vomax REC	L	L / H	L	L	L
REC EQ THD	THD REC	L	L / H	L	L	L
REC EQ S/N	S / N REC	L	L / H	L	L	L

●Control table

Pin No.	Pin name	L	M	H
12	A / B	Ain Active*1	Ain Active	Bin active*1
		Return SW ON	Return SW ON	Return SW OFF
		REC OUT Active	REC OUT Active	REC OUT Hiz
8	REC-IN-SEL	TAPE	MUTE	AUX
9	B CrO ₂	*1, *2	—	*1, *2
10	A CrO ₂	*1	—	*1
11	HSP	Normal	—	Hi speed

*1 PB-EQ LOGIC

*2 REC-EQ LOGIC

A CrO ₂	B CrO ₂	HSP			
		L		H	
		A/B			
		L	H	L	H
L	L	120 μ	120 μ	60 μ	60 μ
L	H	120 μ	70 μ	60 μ	35 μ
H	L	70 μ	120 μ	35 μ	60 μ
H	H	70 μ	70 μ	35 μ	35 μ

B CrO ₂	HSP	
	L	H
L	Normal speed	High speed
	Normal Tape	Normal Tape
H	Normal speed	High speed
	Chrome Tape	Chrome Tape

●External dimensions (Units: mm)

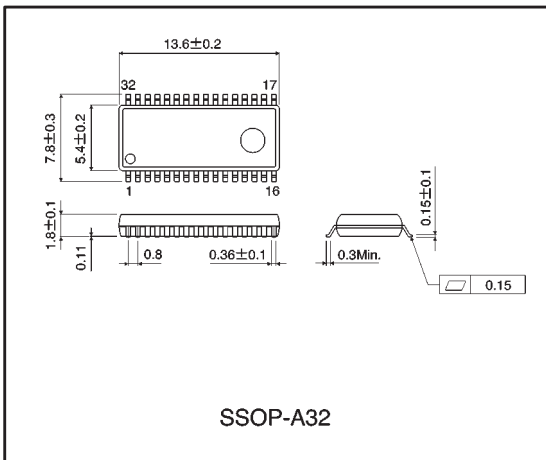



LittleDiode supplies new, hard to find or obsolete electronic components and semiconductors all over the world.

With over two million different components listed you are sure to find the part you need.

Feel free to visit us today at our online store:

LittleDiode.com

Looking forward to providing you with the best possible service.