

Headphone / speaker amplifier for notebook computers

BA7786FP-Y / BA7787FS

The BA7786FP-Y and BA7787FS are sound amplifiers designed for notebook computers, and contain a suspend function and input pins for the system beep and PM beep sounds used by notebook computers. In short, this single-chip IC contains all the analog audio components needed for notebook computers.

Product	H.P.amp	S.P.amp	Other functions
BA7786FP-Y	Stereo	Stereo	SYSTEM / PM BEEP input, SUSPEND, EVR, MUTE, BEEP level control
BA7787FS	Stereo	Monaural	

●Applications

Notebook computers

●Features

- 1) Stereo headphone amplifier that supports mixing input, along with a stereo speaker amplifier (BA7786FP-Y) or BTL monaural speaker amplifier (BA7787FS).
- 2) Internal anti-pop circuit, to prevent the popping sounds that occur when the power is turned on and off.
- 3) Internal electronic volume switch and mute circuit.
- 4) Separate suspend modes for the headphone amplifier and speaker amplifier, for low-power-consumption computers.
- 5) Two beep input pins, a necessity for notebook computers.

●Absolute maximum ratings (Ta = 25°C)

Parameter	Symbol	Limits	Unit
Power supply voltage	V _{cc}	6	V
Power dissipation	BA7786FP-Y	850*1	mW
	BA7787FS	600*2	
Operating temperature	T _{opr}	- 10 ~ + 70	°C
Storage temperature	T _{stg}	- 55 ~ + 125	°C

*1 Reduced by 6.8mW for each increase in Ta of 1°C over 25°C.

*2 Reduced by 6.0mW for each increase in Ta of 1°C over 25°C.

●Recommended operating conditions (Ta = 25°C)

Parameter	Symbol	Min.	Typ.	Max.	Unit
Power supply voltage	V _{cc}	4.5	5.0	5.5	V

●Block diagram

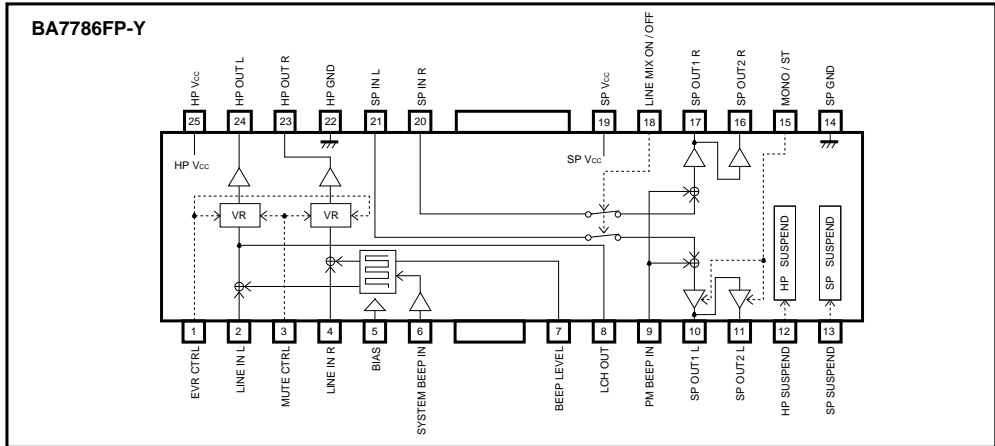

●Pin descriptions

BA7786FP-Y

Pin No.	Pin name	Function	Voltage	Type
1	EVR CTRL	EVR control pin	—	B (NPN)
2	LINE IN L	Line Lch input	2.5	B (PNP)
3	MUTE CTRL	Headphone mute control pin	5.0	100kΩ PULL UP
4	LINE IN R	Line Rch input	2.5	B (PNP)
5	BIAS	Bias	2.5	23.5kΩ
6	SYSTEM BEEP IN	SYSTEM BEEP input	2.5	B (NPN)
7	BEEP LEVEL	SYSTEM BEEP IN output level setting	4.2	C (PNP) ~ 3kΩ
8	LCH OUT	LINE IN L + SYSTEM BEEP IN output	—	C (PNP)
9	PM BEEP IN	PM beep input	2.5	B (NPN)
10	SP OUT1 L	BTL speaker Lch output (forward)	2.5	EF (NPN)
11	SP OUT2 L	BTL speaker Lch output (reverse)	2.5	EF (NPN)
12	HP SUSPEND	Headphone SUSPEND control	5.0	100kΩ PULL UP
13	SP SUSPEND	Speaker SUSPEND control	5.0	100kΩ PULL UP
14	SP GND	Speaker ground	0.0	—
15	MONO / ST	Speaker amplifier Lch ON / OFF control	5.0	100kΩ PULL UP
16	SP OUT2 R	BTL speaker Rch output (reverse)	2.5	EF (NPN)
17	SP OUT1 R	BTL speaker Rch output (forward)	2.5	EF (NPN)
18	LINE MIX ON / OFF	SP IN L / R input ON / OFF control	5.0	100kΩ PULL UP
19	SP Vcc	Speaker Vcc	5.0	—
20	SP IN R	Speaker Rch input	2.5	B (NPN)
21	SP IN L	Speaker Lch input	2.5	B (NPN)
22	HP GND	Headphone ground	0.0	—
23	HP OUT R	Headphone Rch output	2.5	EF (NPN)
24	HP OUT L	Headphone Lch output	2.5	EF (NPN)
25	HP Vcc	Headphone Vcc	5.0	—

Note) The pin formats are as follows. EF: emitter follower; B: base; C: collector; - : series connection.

The above values are all based on the settings (HP Vcc = SP Vcc = + 5.0V) in Fig. 1, entitled "Measurement circuit diagram," and do not guarantee standards.

●Block diagram

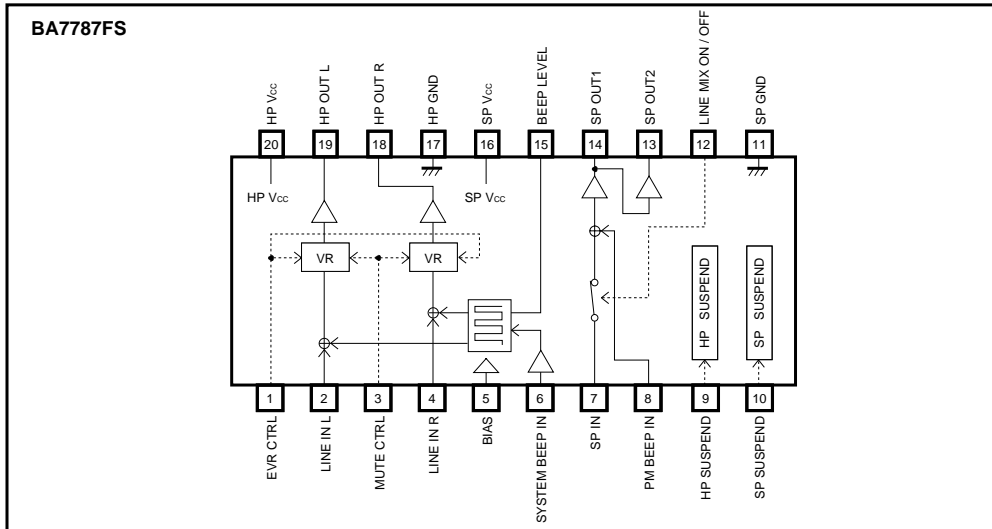

BA7787FS

Pin No.	Pin name	Function	Pin voltage	Pin type
1	EVR CTRL	EVR control pin	—	B (NPN)
2	LINE IN L	Line Lch input	2.5	B (PNP)
3	MUTE CTRL	Headphone mute control	5.0	100kΩ PULL UP
4	LINE IN R	Line Rch input	2.5	B (PNP)
5	BIAS	Bias	2.5	23.5kΩ
6	SYSTEM BEEP IN	SYSTEM BEEP input	2.5	B (NPN)
7	SP IN	Speaker input	2.5	B (NPN)
8	PM BEEP IN	PM BEEP input	2.5	B (NPN)
9	HP SUSPEND	Headphone SUSPEND control	—	B (PNP)
10	SP SUSPEND	Speaker SUSPEND control	—	B (PNP)
11	SP GND	Speaker ground	0.0	—
12	LINE MIX ON / OFF	SP IN input ON / OFF control	5.0	100kΩ PULL UP
13	SP OUT2	BTL speaker output (reverse)	2.5	EF (NPN)
14	SP OUT1	BTL speaker output (forward)	2.5	EF (NPN)
15	BEEP LEVEL	SYSTEM BEEP IN output level setting	4.2	C (PNP) ~ 3kΩ
16	SP Vcc	Speaker Vcc	5.0	—
17	HP GND	Headphone ground	0.0	—
18	HP OUT R	Headphone Rch output	2.5	EF (NPN)
19	HP OUT L	Headphone Lch output	2.5	EF (NPN)
20	HP Vcc	Headphone Vcc	5.0	—

Note) The pin formats are as follows. EF: emitter follower, B: base, C: collector, ~ : series connection.

The above values are all based on the settings (HP Vcc = SP Vcc = + 5.0V) in Fig. 2, entitled "Measurement circuit diagram," and do not guarantee standards.

● Control pin circuits

BA7786FP-Y

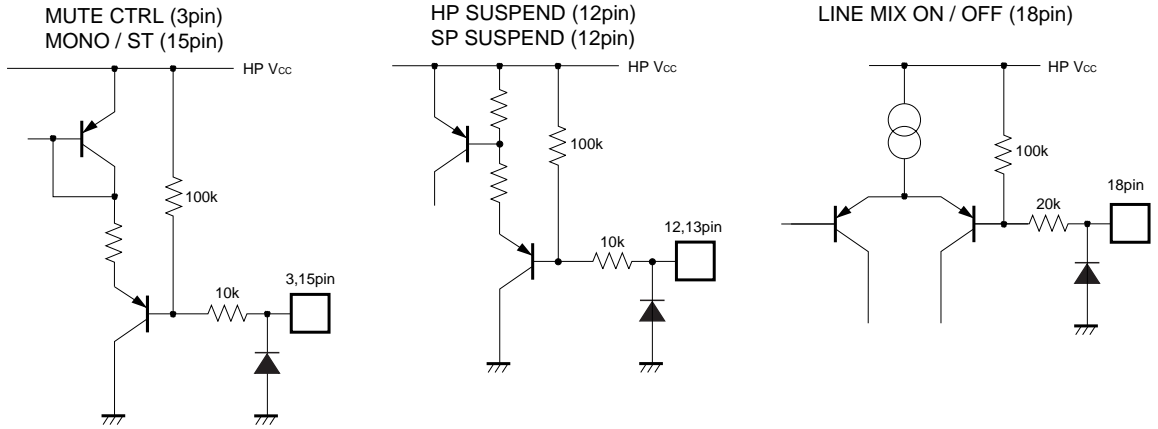

BA7787FS

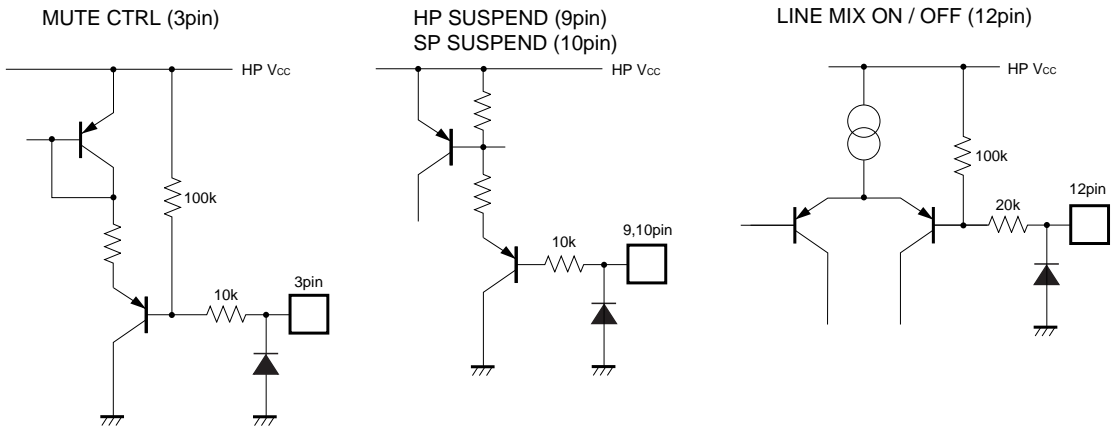

Note) All figures are design values, and do not represent guaranteed performance.

●Electrical characteristics (unless otherwise noted, Ta = 25°C, HP V_{CC} = SP V_{CC} = 5.0V, f = 1kHz)

BA7786FP-Y

Parameter	Symbol	Min.	Typ.	Max.	Unit	Conditions	Measurement circuit
〈Supply current〉							
Supply current	I _{CC}	3.52	4.82	7.64	mA	No input, SP OUT = no load	Fig.1
Supply current SUSPEND	I _{CCS}	175	240	410	μA	No input, V _H = V _S = H	Fig.1
〈HP AMP 1〉 INPUT: LINE IN L / R, OUTPUT: HP OUT L / R							
Output voltage level	V _{OHP}	- 7.4	- 4.0	- 1.5	dBV	V _{IN} = - 10.0dBV	Fig.1
Distortion	THD _{HP}	—	0.1	1.0	%	V _{IN} = - 10.0dBV* ¹	Fig.1
EVR variation range	G _{EVR}	70	90	—	dB	V _{IN} = - 10.0dBV* ² V _E = HP V _{CC} → V _E = ground level differential	Fig.1
Maximum output level	V _{OMHP}	- 1.6	+ 0.6	—	dBV	THD = 1%* ¹	Fig.1
Output residual noise	V _{ONHP}	—	- 80	- 73	dBV	R _g = 1kΩ* ²	Fig.1
Interchannel crosstalk	CT _{HP}	—	- 79	- 70	dBV	V _{IN} = - 7.0dBV* ²	Fig.1
Muting level	MT _{HP}	—	- 94	- 83	dBV	V _{IN} = - 7.0dBV* ² , V _M = L	Fig.1
〈HP AMP 2〉 INPUT: SYSTEM BEEP IN, OUTPUT: HP OUT L / R							
Output voltage level	V _{OHB}	0.22	0.32	0.42	V _{P-P}	V _{IN} = 5.0V _{P-P}	Fig.1
Input threshold level	V _{HBH}	4.5	—	5.0	V _{P-P}		Fig.1
〈SP AMP 1〉 INPUT: SP IN L / R, OUTPUT: SP OUT L / R							
Output voltage level	V _{OSP}	- 1.4	+ 2.0	+ 4.5	dBV	V _{IN} = - 10.0dBV	Fig.1
Distortion	THD _{SP}	—	0.4	1.5	%	V _{IN} = - 10.0dBV* ¹	Fig.1
Maximum output level	V _{OMSP}	+ 3.5	+ 5.7	—	dBV	THD = 1%* ¹	Fig.1
Output residual noise	V _{ONSP}	—	- 90	- 80	dBV	R _g = 1kΩ* ²	Fig.1
Interchannel crosstalk	CT _{SP}	—	- 78	- 70	dBV	V _{IN} = - 12.0dBV* ²	Fig.1
LINE MIX OFF level	V _{OOFFSP}	—	- 78	- 70	dBV	V _{IN} = - 12.0dBV* ² , V _L = L	Fig.1
〈SP AMP 2〉 INPUT: PM BEEP IN, OUTPUT: SP OUT L / R							
Output level	V _{OSB}	- 7.4	- 4.0	- 1.5	dBV	V _{IN} = - 10.0dBV	Fig.1
〈MUTE CTRL〉 (pin 13)							
HP MUTE ON holding voltage	V _{ML}	GND	—	0.4	V		Fig.1
HP MUTE OFF holding voltage	V _{MH}	4.3	—	V _{CC}	V		Fig.1
〈HP SUSPEND〉 (pin 12)							
HP SUSPEND holding voltage	V _{HL}	GND	—	0.4	V		Fig.1
HP SUSPEND holding voltage	V _{HH}	4.3	—	V _{CC}	V		Fig.1
〈SP SUSPEND〉 (pin 13)							
HP SUSPEND holding voltage	V _{SL}	GND	—	0.4	V		Fig.1
HP SUSPEND holding voltage	V _{SH}	4.3	—	V _{CC}	V		Fig.1
〈MONO / STEREO〉 (pin 15)							
MONAURAL holding voltage	V _{NL}	GND	—	0.4	V		Fig.1
STEREO holding voltage	V _{NH}	4.3	—	V _{CC}	V		Fig.1
〈LINE MIX ON / OFF〉 (pin 18)							
LINE MIX OFF holding voltage	V _{LL}	GND	—	0.4	V		Fig.1
LINE MIX ON holding voltage	V _{LH}	4.3	—	V _{CC}	V		Fig.1

*1: B.W. = 0.4 ~ 30kHz

*2: DIN audio mode settings are as follows, unless otherwise noted:

V_E = HP V_{CC} (EVR = Max.), V_M = H (HP MUTE OFF), V_H = L (HP SUSPEND), V_S = L (SP SUSPEND), V_L = H (LINE MIX ON), V_N = H (STEREO)

BA7787FS

Parameter	Symbol	Min.	Typ.	Max.	Unit	Conditions	Measurement circuit
〈Supply current〉							
Supply current	I _{CC}	3.10	4.25	6.74	mA	No input, SP OUT = no load	Fig.2
Supply current SUSPEND	I _{CCS}	175	240	410	μA	No input, V _H = V _S = H	Fig.2
〈HP AMP 1〉 INPUT: LINE IN L / R, OUTPUT: HP OUT L / R							
Output voltage level	V _{OHP}	- 7.4	- 4.0	- 1.5	dBV	V _{IN} = - 10.0dBV	Fig.2
Distortion	THD _{HP}	—	0.1	1.0	%	V _{IN} = - 10.0dBV*1	Fig.2
EVR variation range	G _{EVR}	70	90	—	dB	V _{IN} = - 10.0dBV*2 V _E = HP V _{CC} →V _E = ground level differential	Fig.2
Maximum output level	V _{OMHP}	- 1.6	+ 0.6	—	dBV	THD = 1%*1	Fig.2
Output residual noise	V _{ONHP}	—	- 80	- 73	dBV	R _g = 1kΩ*2	Fig.2
Interchannel crosstalk	CT _{HP}	—	- 79	- 70	dBV	V _{IN} = - 7.0dBV*2	Fig.2
Muting level	MT _{HP}	—	- 94	- 83	dBV	V _{IN} = - 7.0dBV*2, V _M = L	Fig.2
〈HP AMP 2〉 INPUT: SYSTEM BEEP IN, OUTPUT: HP OUT L / R							
Output voltage level	V _{OHB}	0.22	0.32	0.42	V _{P-P}	V _{IN} = 5.0V _{P-P}	Fig.2
Input threshold level	V _{HBH}	4.5	—	5.0	V _{P-P}		Fig.2
〈SP AMP 1〉 INPUT: SP IN L / R, OUTPUT: SP OUT L / R							
Output voltage level	V _{OSP}	- 1.4	+ 2.0	+ 4.5	dBV	V _{IN} = - 10.0dBV	Fig.2
Distortion	THD _{SP}	—	0.4	1.5	%	V _{IN} = - 10.0dBV*1	Fig.2
Maximum output level	V _{OMSP}	+ 3.5	+ 5.7	—	dBV	THD = 1%*1	Fig.2
Output residual noise	V _{ONSP}	—	- 90	- 80	dBV	R _g = 1kΩ*2	Fig.2
Interchannel crosstalk	CT _{SP}	—	- 78	- 70	dBV	V _{IN} = - 12.0dBV*2	Fig.2
LINE MIX OFF level	V _{OFFSP}	—	- 78	- 70	dBV	V _{IN} = - 12.0dBV*2, V _L = L	Fig.2
〈SP AMP 2〉 INPUT: PM BEEP IN, OUTPUT: SP OUT L / R							
Output level	V _{OSB}	- 7.4	- 4.0	- 1.5	dBV	V _{IN} = - 10.0dBV	Fig.2
〈Control threshold voltage〉							
〈MUTE CTRL〉 (pin 3)							
HP MUTE ON holding voltage	V _{ML}	GND	—	0.4	V	—	Fig.2
HP MUTE OFF holding voltage	V _{MH}	4.3	—	V _{CC}	V	—	Fig.2
〈HP SUSPEND〉 (pin 9)							
HP SUSPEND holding voltage	V _{HL}	GND	—	0.4	V	—	Fig.2
HP SUSPEND holding voltage	V _{HH}	4.3	—	V _{CC}	V	—	Fig.2
〈SP SUSPEND〉 (pin 10)							
SP SUSPEND holding voltage	V _{SL}	GND	—	0.4	V	—	Fig.2
SP SUSPEND holding voltage	V _{SH}	4.3	—	V _{CC}	V	—	Fig.2
〈LINE MIX ON / OFF〉 (pin 12)							
LINE MIX OFF holding voltage	V _{LL}	GND	—	0.4	V	—	Fig.2
LINE MIX ON holding voltage	V _{LH}	4.3	—	V _{CC}	V	—	Fig.2

*1: B.W. = 0.4 ~ 30kHz

*2: DIN audio mode settings are as follows, unless otherwise noted:

V_E = HP V_{CC} (EVR = Max.), V_M = H (HP MUTE OFF), V_H = L (HP SUSPEND), V_S = L (SP SUSPEND), V_L = H (LINE MIX ON), V_N = H (STEREO)

● Measurement circuit

BA7786FP-Y

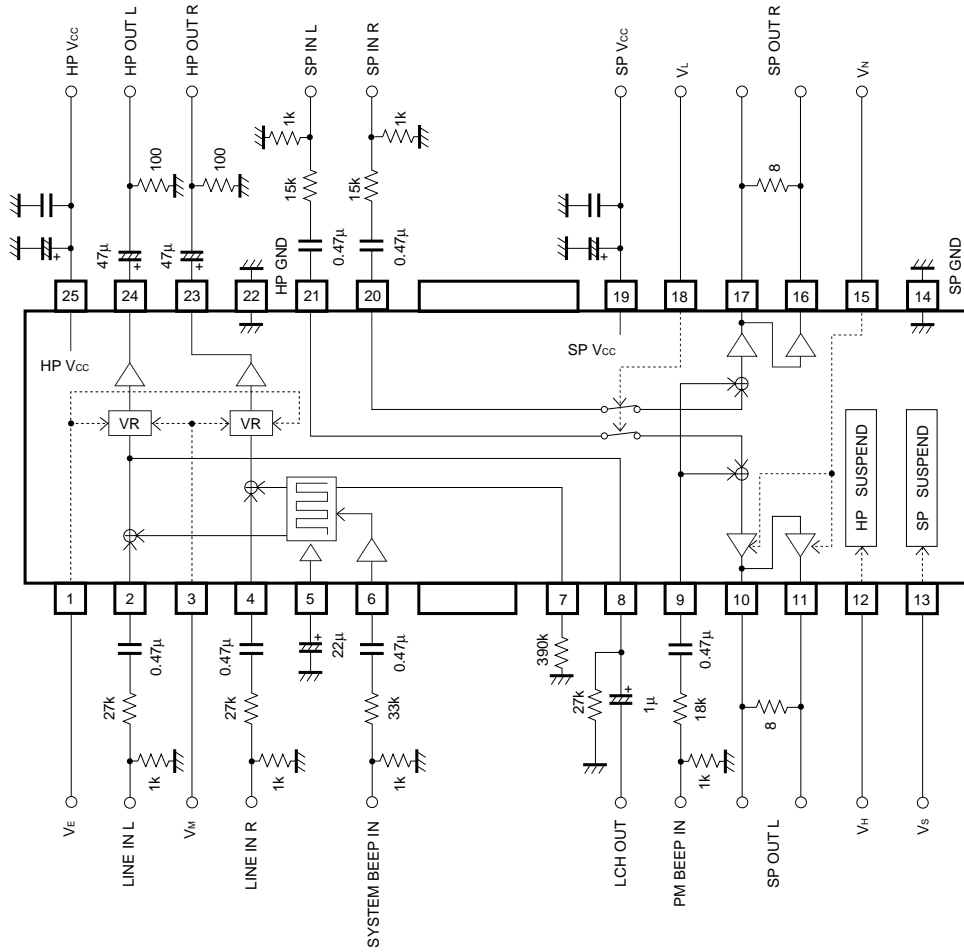

Fig.1

BA7787FS

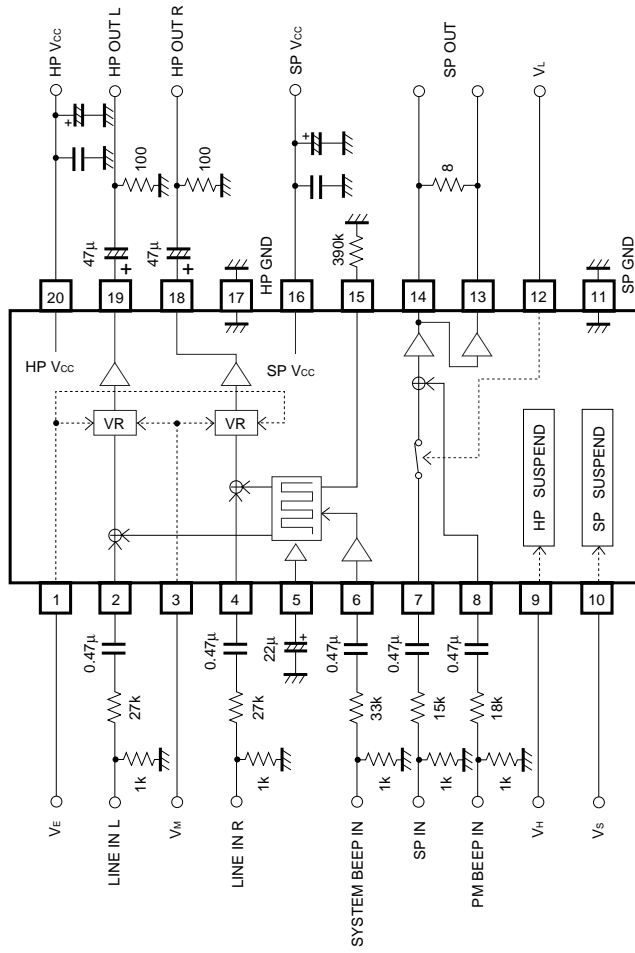

Fig.2

●Circuit operation

(1) Gain between LINE IN L / LINE IN R and HP OUT L / HP OUT R

G_{HP} , the gain when EVR is at its maximum ($V_E = HP V_{CC}$), is calculated as follows:

$$G_{HP} \approx 20 * \text{LOG} \frac{60k}{1k + R} \text{ (dB)}$$

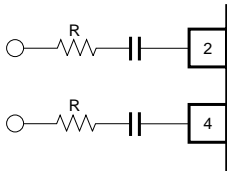

Set so that $12k \leq R \leq 56k$. This gain attenuates according to the pin 1 DC voltage (V_E) (see Fig. 8). Mixing input can be accommodated by attaching multiple resistors.

(2) Output level between SYSTEM BEEP IN and HP OUT L / HP OUT R

Inputting a pulse wave to SYSTEM BEEP IN causes HP OUT L and HP OUT R to output a pulse wave. The output level of this pulse wave depends on the resistance between pin 7 and GND. The level when EVR is at its maximum ($V_E = HP V_{CC}$) is calculated as follows.

$$V_{HB} \approx 0.5 * \frac{V_{CC} - 0.7}{13k + R} * 60k \text{ (V}_{P-P}\text{)}$$

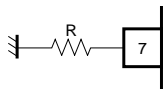

(BA7786FP-Y only, BA7787FS: pin 15)

Set so that $R \geq 100k$ ($V_{HB} \leq 1.1V$). As with the path between LINE IN L / LINE IN R and HP OUT L / HP OUT R, this level attenuates according to the pin 1 DC voltage.

(3) Gain between SP IN L / SP IN R and SP OUT L / SP OUT R (BA7786FP-Y)

This is calculated as follows.

$$G_{SP} \approx 20 * \text{LOG} \frac{32k}{1k + R} \text{ (dB)}$$

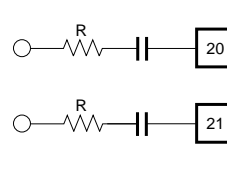

Gain between SP IN and SP OUT 1 / SP OUT 2 (BA7787FS)

This is calculated as follows.

$$G_{SP} \approx 20 * \text{LOG} \frac{32k}{1k + R} \text{ (dB)}$$

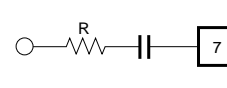

(4) Gain between PM BEEP IN and SP OUT 1 / SP OUT 2

This is calculated as follows.

$$G_{SB} \approx 20 * \text{LOG} \frac{20k}{1k + R} \text{ (dB)}$$

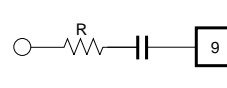

(BA7786FP-Y only, BA7787FS: pin 8)

This path is output regardless of whether LIN MIX ON / OFF is at the high or low level.

(5) Gain between LINE IN L and LCH OUT

(BA7786FP-Y)

This gain (G_{HL}) is calculated as follows.

$$G_{HL} \approx 20 * \text{LOG} \frac{R8}{2 * R2} \text{ (dB)}$$

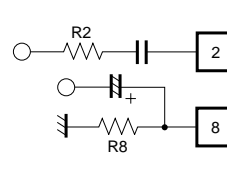

This path is not controlled by EVR or the mute function.

(6) Output level between SYSTEM BEEP IN and LCH OUT (BA7786FP-Y)

Inputting a pulse wave to SYSTEM BEEP IN causes LCH OUT to output a pulse wave. The output level of this pulse wave depends on the resistance between pin 7 and GND and between pin 8 and GND, and is calculated as follows.

$$V_{HS} \approx 0.25 * \frac{V_{CC} - 0.7}{13k + R7} * R8 \text{ (V}_{P-P}\text{)}$$

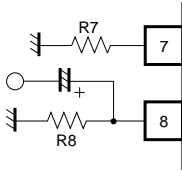

This path is not controlled by EVR or the mute function.

(7) EVR control characteristics

The headphone amplifier is controlled by changing the resistive potential division ratio.

●Control pins

(1) MUTE CTRL

- Turns the headphone mute function on and off.

	Control signal: V _M	Note
HP MUTE ON	L	Turns off HP AMP output
HP MUTE OFF	H (OPEN)	—

(2) HP SUSPEND

- Turns the headphone suspend function on and off.

	Control signal: V _H	Note
HP SUSPEND	L	The headphone amplifier operates
HP SUSPEND	H	The headphone amplifier turns off

- Because the BA7786FP-Y has a pull-up resistor, this is possible even when open (if at the high level).

(3) SP SUSPEND

- Turns the speaker suspend function on and off.

	Control signal: V _S	Note
SP SUSPEND	L	The speaker amplifier operates
SP SUSPEND	H	The speaker amplifier turns off

- Because the BA7786FP-Y has a pull-up resistor, this is possible even when open (if at the high level).

(4) LINE MIX ON / OFF

- Turns the SP IN input on and off according to SP OUT.

	Control signal: V _L	Note
LINE MIX OFF	L	Stops the output of SP IN input to SP OUT
LINE MIX ON	H (OPEN)	—

(5) MONO / STEREO (BA7786FP-Y)

- Turns SP AMP LCH on and off.

	Control signal: V _N	Note
SP AMP LCH OFF	L	SP AMP LCH turns off
SP AMP LCH ON	H (OPEN)	SP AMP LCH operates

●Application example
BA7786FP-Y

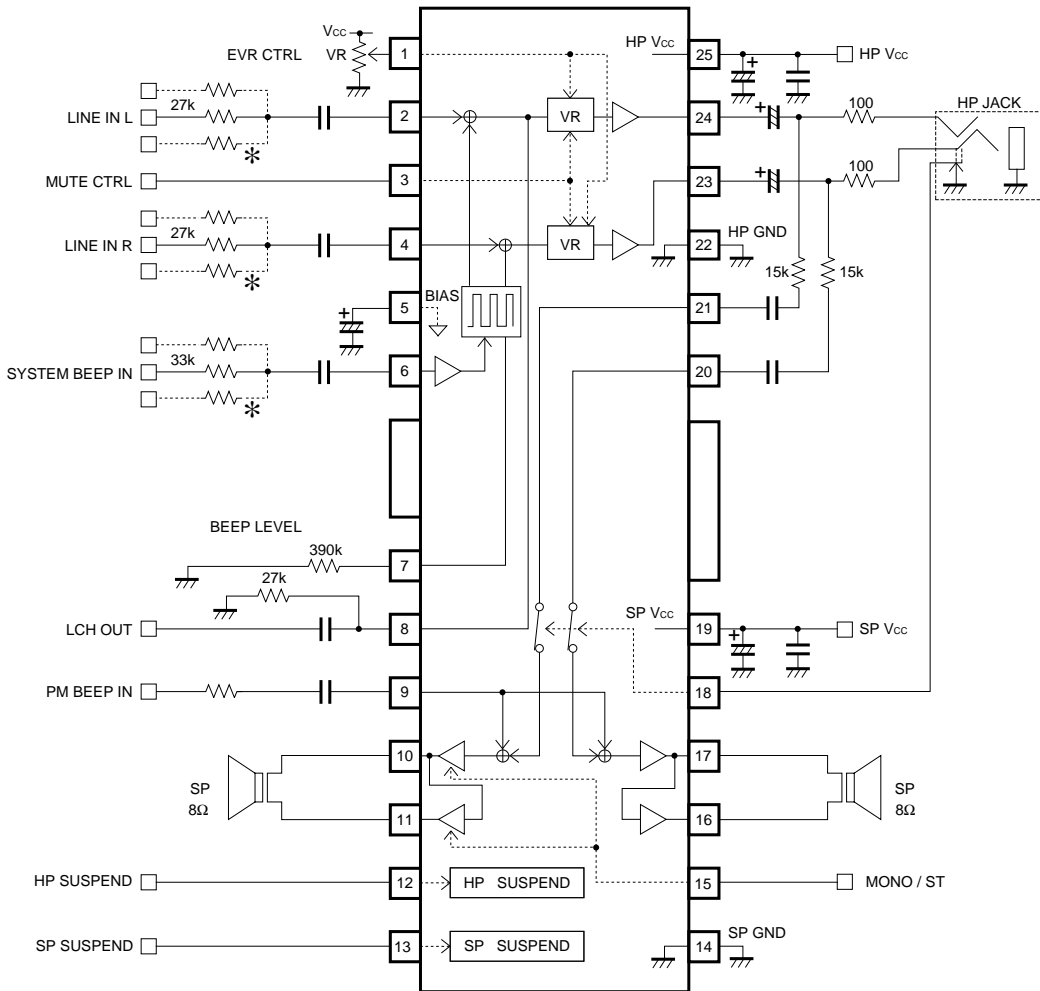

* □-----∩----- is for mixing input.

Fig.3

Pin No.	TERMINAL NAME	FUNCTION		TERMINAL FORM
		L	H	
3	MUTE CTRL	HP MUTE ON	HP MUTE OFF	100k PULL UP
12	HP SUSPEND	HP OPERATED	HP SUSPENDED	100k PULL UP
13	SP SUSPEND	SP OPERATED	SP SUSPENDED	100k PULL UP
15	MONO / ST	LCH SP OFF	LCH SP ON	100k PULL UP
18	LINE MIX ON / OFF	LINE MIX OFF	LINE MIX ON	100k PULL UP

BA7787FS

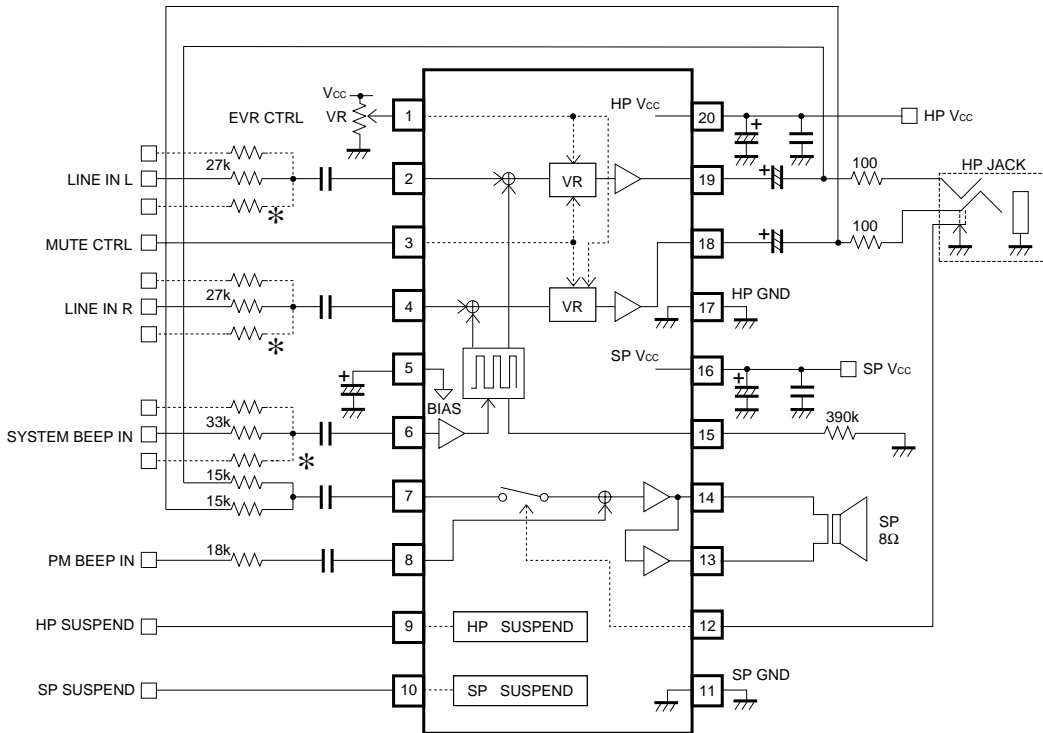

* □-----∩----- is for mixing input

Fig.4

Pin No.	TERMINAL NAME	FUNCTION		TERMINAL FORM
		L	H	
3	MUTE CTRL	HP MUTE ON	HP MUTE OFF	100k PULL UP
9	HP SUSPEND	HP OPERATED	HP SUSPENDED	PNP BASE
10	SP SUSPEND	SP OPERATED	SP SUSPENDED	PNP BASE
12	LINE MIX ON / OFF	LINE MIX OFF	LINE MIX ON	100k PULL UP

●Electrical characteristic curves

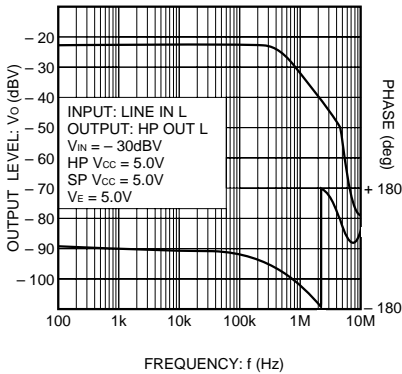

Fig. 5 HP AMP frequency characteristics

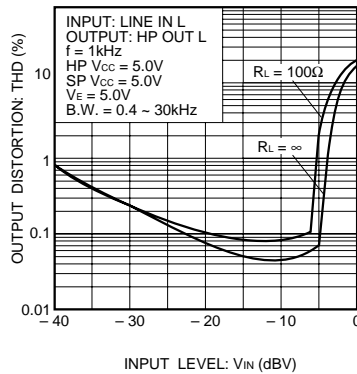

Fig. 6 HP AMP input level vs. output distortion

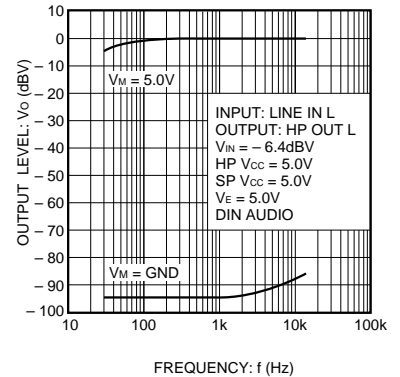

Fig. 7 HP AMP MUTE characteristics

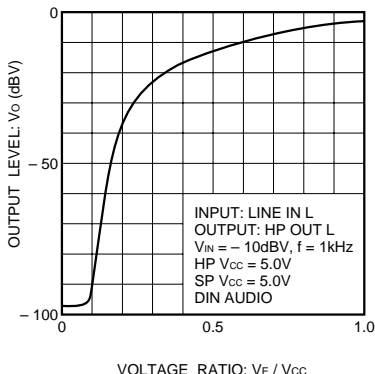

Fig. 8 HP AMP EVR characteristics

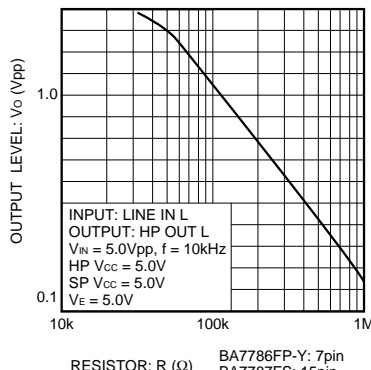

Fig. 9 SYSTEM BEEP output level vs. external resistor.

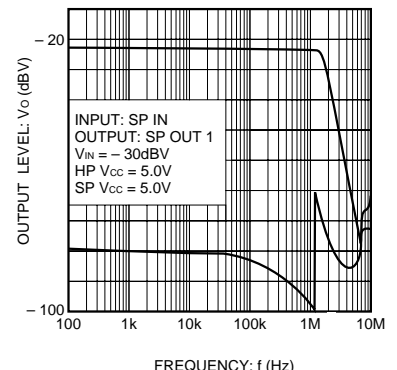

Fig. 10 SP AMP frequency characteristics

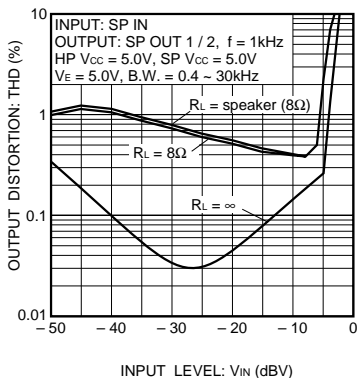

Fig. 11 SP AMP input level vs. output distortion

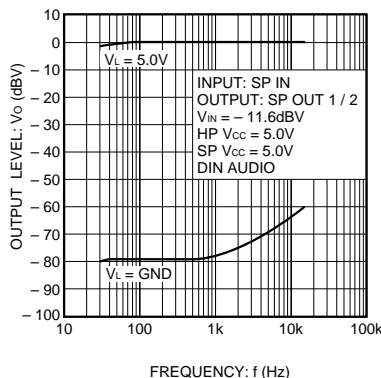

Fig. 12 SP AMP MUTE characteristics

●Board circuit
BA7786FP-Y

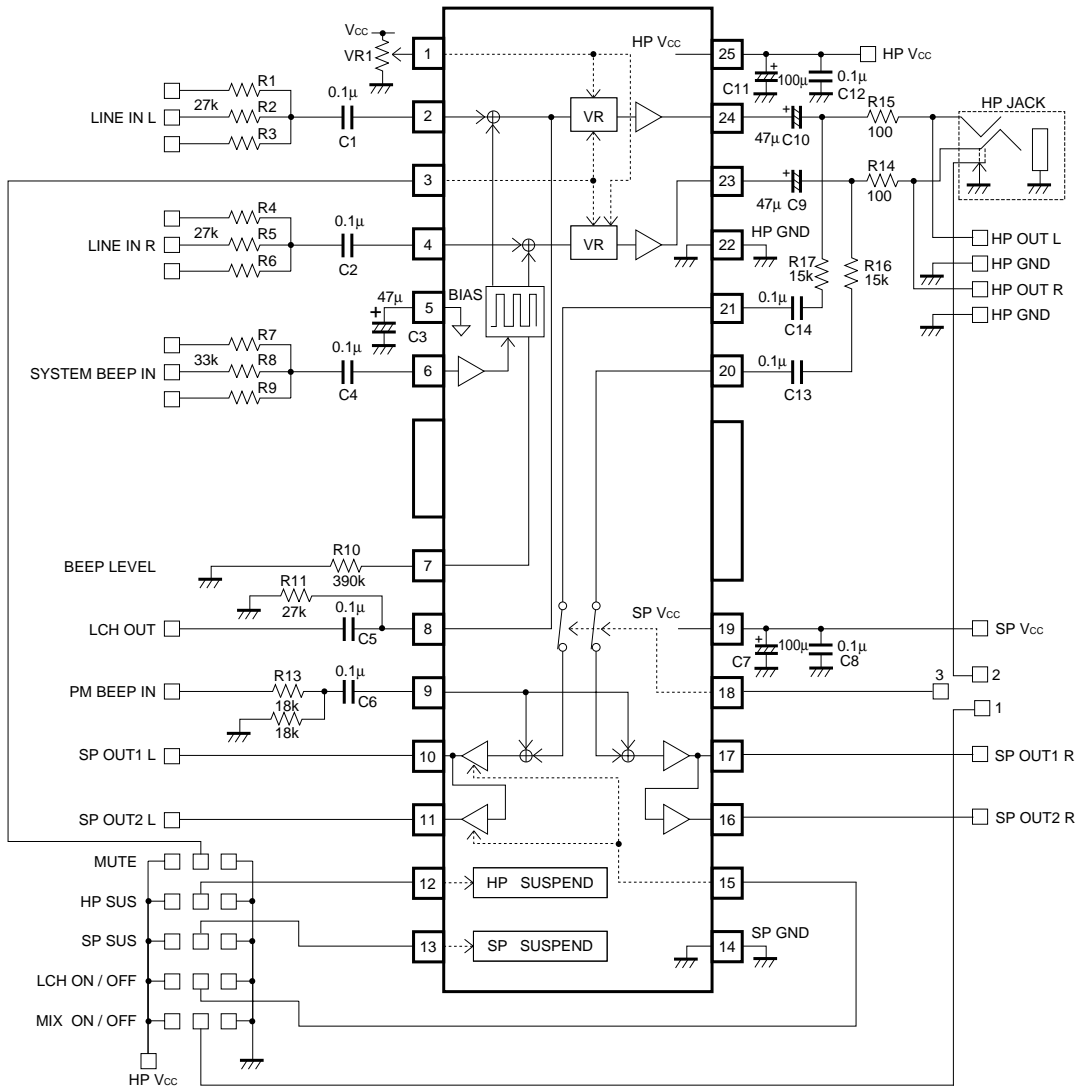

Fig. 13

BA7787FS

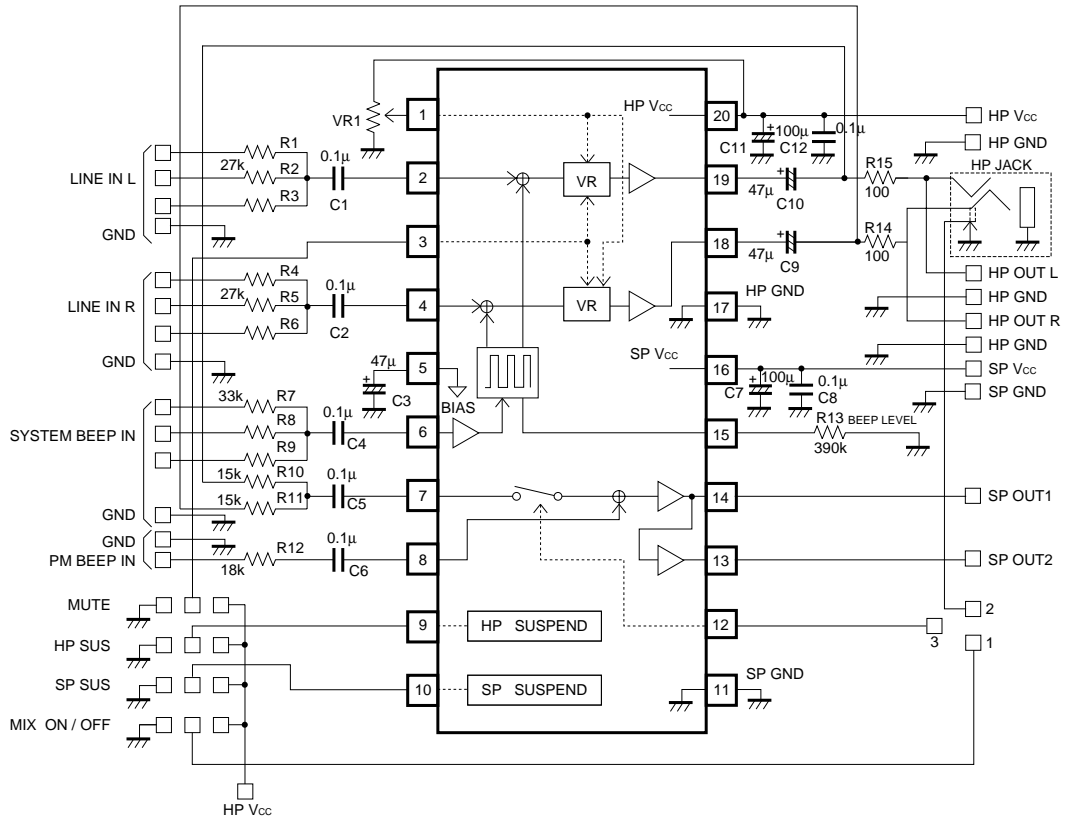

Fig. 14

●Part table

BA7786FP-Y

No.	Use	Standard value
R1	Used to set the gain from LINE IN L / LINE IN R (pins 2 and 4) to HP OUT L / HP OUT R (pins 24 and 23) (See section 1, on circuit operation for the formula.) A wide range of mixing ratios can be set by changing the values of R1, R2 and R3 (or R4, R5 and R6).	27k Ω
R2		27k Ω
R3		27k Ω
R4		27k Ω
R5		27k Ω
R6		27k Ω
R7	Resistors for mixing SYSTEM BEEP IN (pin 6). Because the threshold voltage between the high and low levels is fixed inside the IC, these resistors should be set to 33k Ω	33k Ω
R8		33k Ω
R9		33k Ω
R10	Used to set the output level from SYSTEM BEEP IN (pin 6) to HP OUT L / HP OUT R (pins 24 and 23). (See section 2, on circuit operation for the formula.)	390k Ω
R11	<ul style="list-style-type: none"> • No need to attach. Connect pin 8 to a ground. • Used to set the gain from PM BEEN IN (pin 9) to SP OUT L / SP OUT R (pins 10, 11, 16 and 17). (See section 4, on circuit operation for the formula.) • The load resistor for HP OUT R. • The load resistor for HP OUT L. 	—
R13		18k Ω
R14		100 Ω
R15		100 Ω
R16	Used to set the gain from SP IN L / R (pins 21 and 20) to SP OUT L / R (pins 10, 11, 16 and 17). (See section 3, on circuit operation for the formula.)	15k Ω
R17		15k Ω
C1	<ul style="list-style-type: none"> • The coupling capacitor for LINE IN L • The coupling capacitor for LINE IN R • The ripple rejection capacitor for the bias pin • The coupling capacitor for SYSTEM BEEP IN • No need to attach • The coupling capacitor for PM BEEP IN • The bypass capacitor for SP V_{cc} (used for low-frequency ripple rejection) • The bypass capacitor for SP V_{cc} (used for high-frequency ripple rejection) • The coupling capacitor for HP OUT R • The coupling capacitor for HP OUT L • The bypass capacitor for HP V_{cc} (used for low-frequency ripple rejection) • The bypass capacitor for HP V_{cc} (used for high-frequency ripple rejection) 	0.1 μ F
C2		0.1 μ F
C3		47 μ F
C4		0.1 μ F
C5		—
C6		0.1 μ F
C7		100 μ F
C8		0.1 μ F
C9		47 μ F
C10		47 μ F
C11		100 μ F
C12		0.1 μ F
C13	<ul style="list-style-type: none"> • The coupling capacitor for SP IN R • The coupling capacitor for SP IN L • Used to change the pin 1 DC voltage 	0.1 μ F
C14		0.1 μ F
VR1		20k Ω

BA7787FS

No.	Use	Standard value
R1	Used to set the gain from LINE IN L / LINE IN R (pins 2 and 4) to HP OUT L / HP OUT R (pins 19 and 18) (See section 1, on circuit operation for the formula.) A wide range of mixing ratios can be set by changing the values of R1, R2 and R3 (or R4, R5 and R6).	27k Ω
R2		27k Ω
R3		27k Ω
R4		27k Ω
R5		27k Ω
R6		27k Ω
R7	Resistors for mixing SYSTEM BEEP IN (pin 6). Because the threshold voltage between the high and low levels is fixed inside the IC, these resistors should be set to 33k Ω .	33k Ω
R8		33k Ω
R9		33k Ω
R10	• Used to set the gain from SP IN (pin 7) to SP OUT 1 / SP OUT 2 (pins 14 and 13). (See section 3, on circuit operation for the formula.)	15k Ω
R11		15k Ω
R12	• Used to set the gain from PM BEEP IN (pin 8) to SP OUT 1 / SP OUT 2 (pins 14 and 13). (See section 4, on circuit operation for the formula.)	18k Ω
R13	• Used to set the output level from SYSTEM BEEP IN (pin 6) to HP OUT L / HP OUT R (pins 19 and 18). (See section 2, on circuit operation for the formula.)	390k Ω
R14	• The load resistor for HP OUT R.	100 Ω
R15	• The load resistor for HP OUT L.	100 Ω
C1	• The coupling capacitor for LINE IN L	0.1 μ F
C2	• The coupling capacitor for LINE IN R	0.1 μ F
C3	• The ripple rejection capacitor for the bias pin	47 μ F
C4	• The coupling capacitor for SYSTEM BEEP IN	0.1 μ F
C5	• The coupling capacitor for SP IN	0.1 μ F
C6	• The coupling capacitor for PM BEEP IN	0.1 μ F
C7	• The bypass capacitor for SP V _{CC} (used for low-frequency ripple rejection)	100 μ F
C8	• The bypass capacitor for SP V _{CC} (used for high-frequency ripple rejection)	0.1 μ F
C9	• The coupling capacitor for HP OUT R	47 μ F
C10	• The coupling capacitor for HP OUT L	47 μ F
C11	• The bypass capacitor for HP V _{CC} (used for low-frequency ripple rejection)	100 μ F
C12	• The bypass capacitor for HP V _{CC} (used for high-frequency ripple rejection)	0.1 μ F
VR1	• Used to change the pin 1 DC voltage	20k Ω

● Operation notes

(1) Popping noises occurring when the power is turned on

- When the power is turned on, the headphone mute function should be on and the suspend function off in order to prevent popping noises from occurring when V_{CC} turns on.

(2) The supply voltages for HP V_{CC} and SP V_{CC} should come from the same power supply. Using separate power supplies can lead to output voltage drops and malfunctioning.

(3) The common impedance of the two power supply lines (HP V_{CC} and SP V_{CC}) should be kept as low as possible.

(4) Make sure the input resistance for the SYSTEM BEEP IN pin is $33k\Omega$.

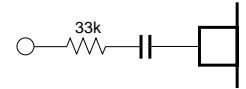

(5) Configure the PM BEEP IN pin of BA7786FP-Y as shown below in order to prevent oscillation in the IC.

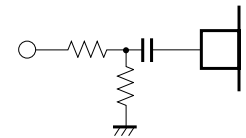

(6) The LCH OUT pin (pin 8) of BA7786FP-Y should be grounded when not used.

(7) When switching the suspend function popping noises may occur. If this bothers, take measures for eliminating it by attaching external components.

●Board labelling diagram
BA7786FP-Y

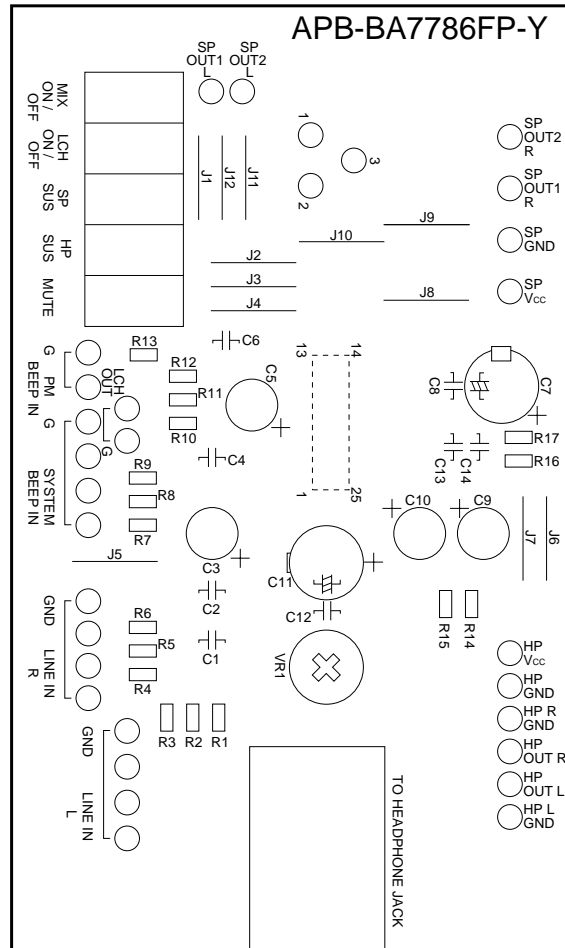

Fig. 15

LINE IN L: Line input Lch

LINE IN R: Line input Rch

SYSTEM BEEP IN: System beep sound input

PM BEEP IN: PM beep sound input

HP OUT L: Headphone output Lch monitor

HP OUT R: Headphone output Rch monitor

SP OUT L 1 / 2: Speaker connection pin (BTL)

SP OUT R 1 / 2: Speaker connection pin (BTL)

SP V_{cc}: Supply voltage input + 5.0V

HP V_{cc}: Supply voltage input + 5.0V

VR1: Electric volume adjuster va

(On this board, G_{HP} is set to its maximum by turning the volume adjuster clockwise as far as it will go.)

MUTE: MUTE control switch

HP SUS: HP suspend control switch

SP SUS: SP suspend control switch

MIX ON / OFF: LINE MIX ON / OFF switch

(On this board, pin 12 automatically drops to the ground level when a headphone is plugged into the jack.)

LCH ON / OFF: SP AMP LCH ON / OFF switch

●Board pattern diagram
BA7786FP-Y

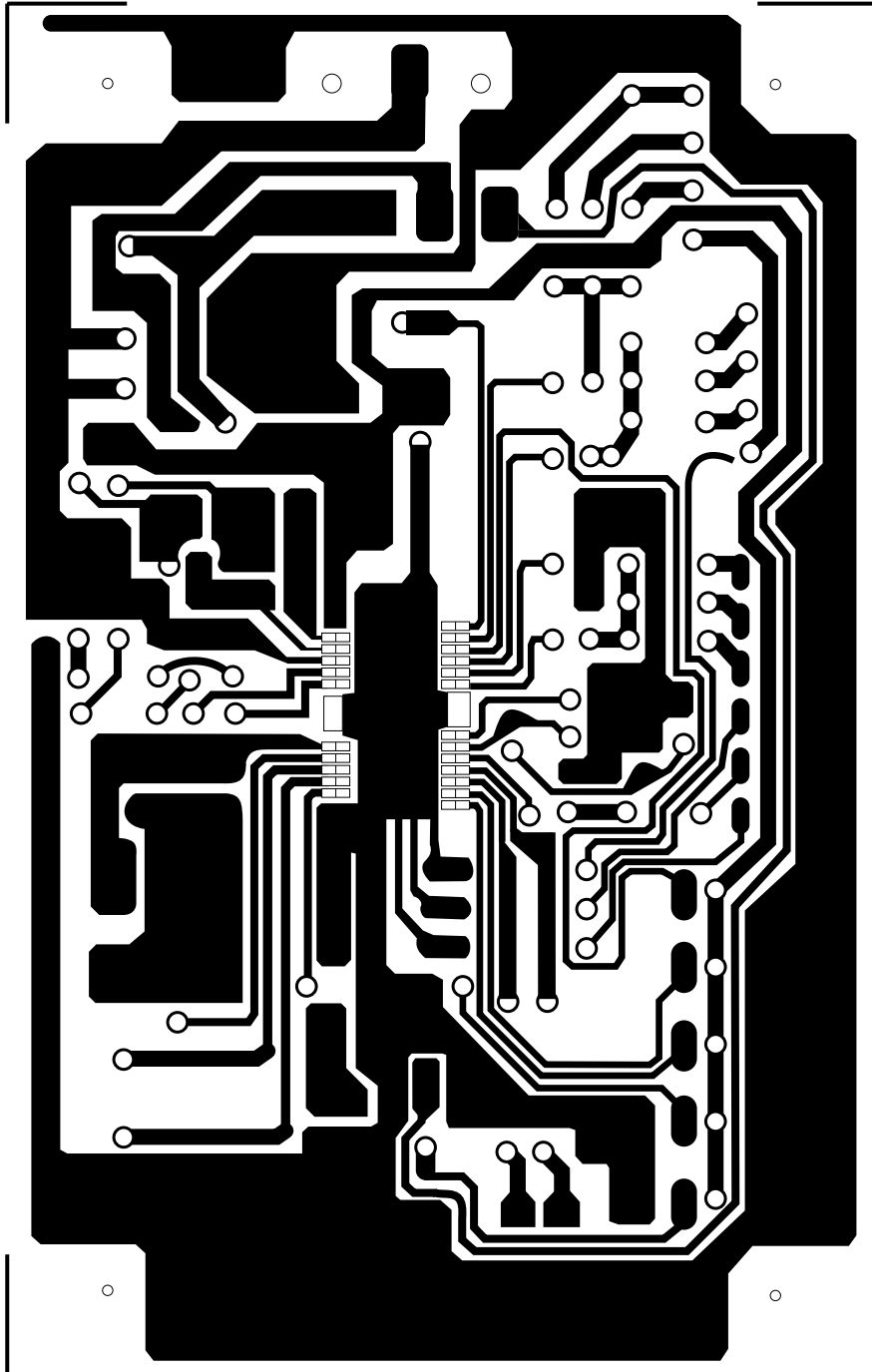

Fig. 16

●Board labelling diagram
BA7787FS

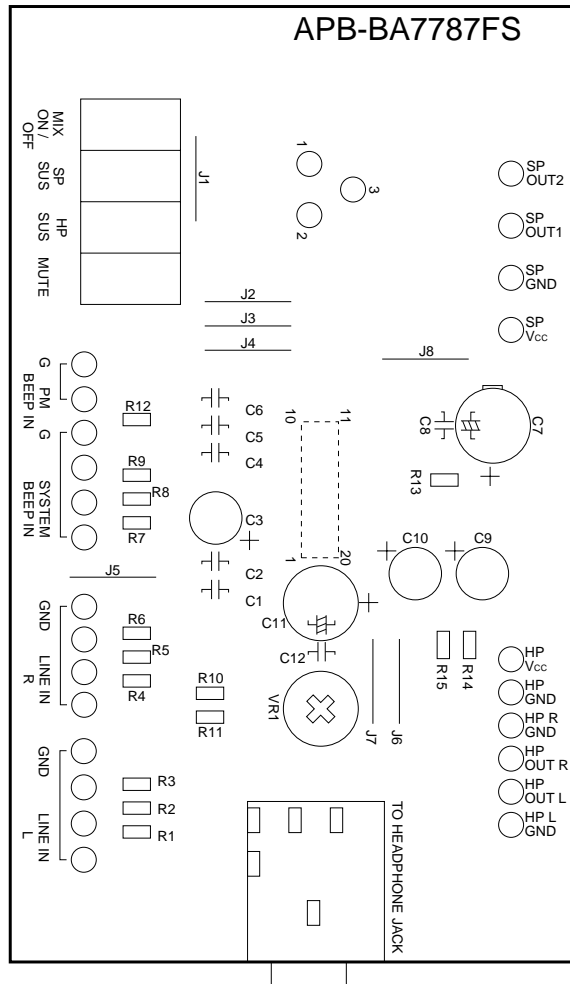

Fig. 17

LINE IN L: Line input Lch
 LINE IN R: Line input Rch
 SYSTEM BEEP IN: System beep sound input
 PM BEEP IN: PM beep sound input
 HP OUT L: Headphone output Lch monitor
 HP OUT R: Headphone output Rch monitor
 SP OUT 1: Speaker connection pin (BTL)
 SP OUT 2: Speaker connection pin (BTL)
 SP V_{cc}: Supply voltage input + 5.0V
 HP V_{cc}: Supply voltage input + 5.0V

VR1: Electric volume adjuster va
 (On this board, G_{HP} is set to its maximum by turning the volume adjuster clockwise as far as it will go.)
 MUTE: MUTE control switch
 HP SUS: HP suspend control switch
 SP SUS: SP suspend control switch
 MIX ON / OFF: LINE MIX ON / OFF switch
 (On this board, pin 12 automatically drops to the ground level when a headphone is plugged into the jack.)

●Board pattern diagram
BA7787FS

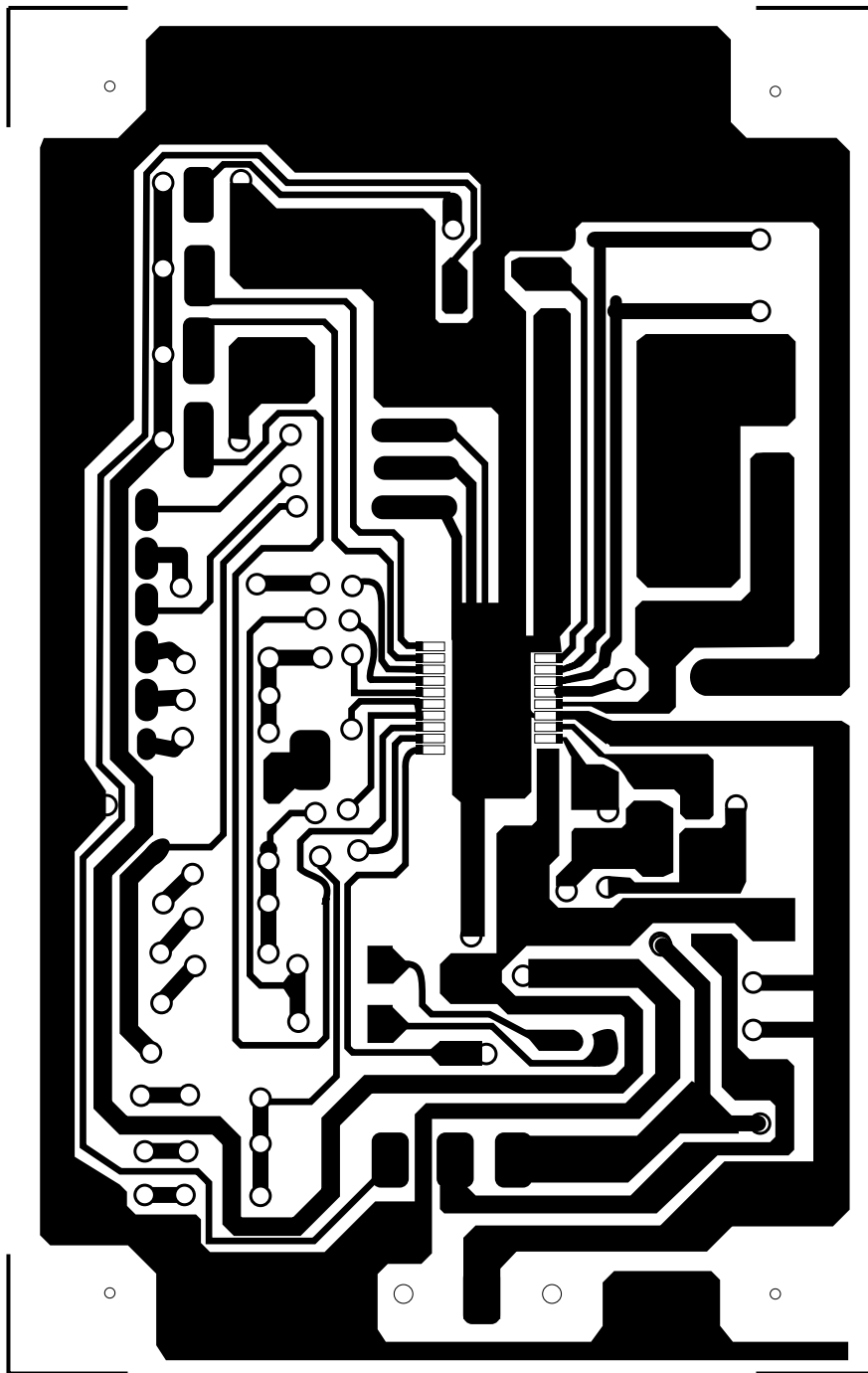
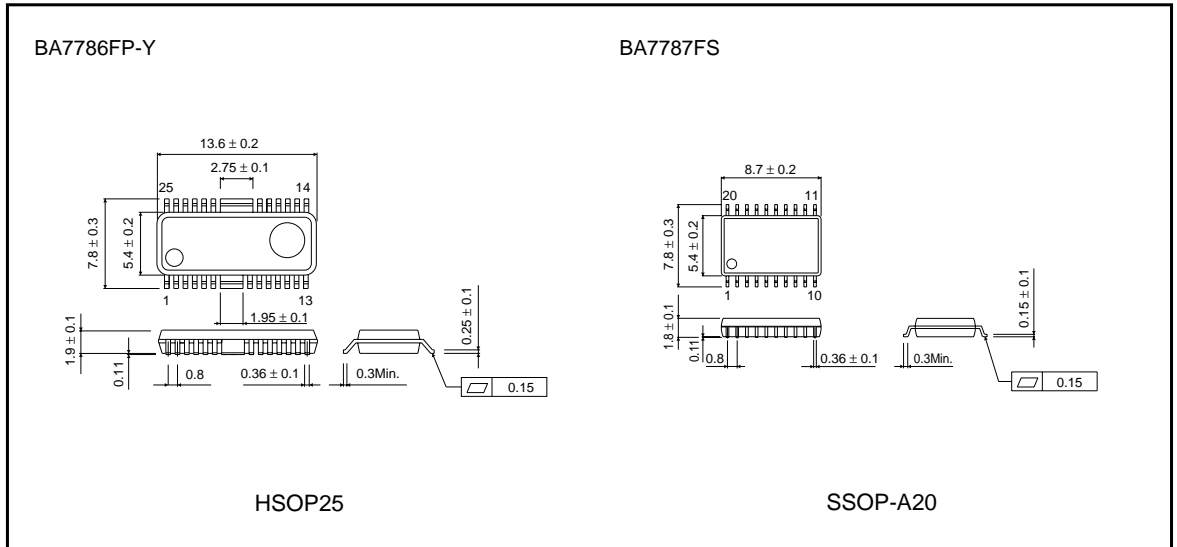

Fig. 18

●External dimensions (Units: mm)





LittleDiode supplies new, hard to find or obsolete electronic components and semiconductors all over the world.

With over two million different components listed you are sure to find the part you need.

Feel free to visit us today at our online store:

LittleDiode.com

Looking forward to providing you with the best possible service.