

Lead-Mount Triac 1 Ampere/400-600 Volts

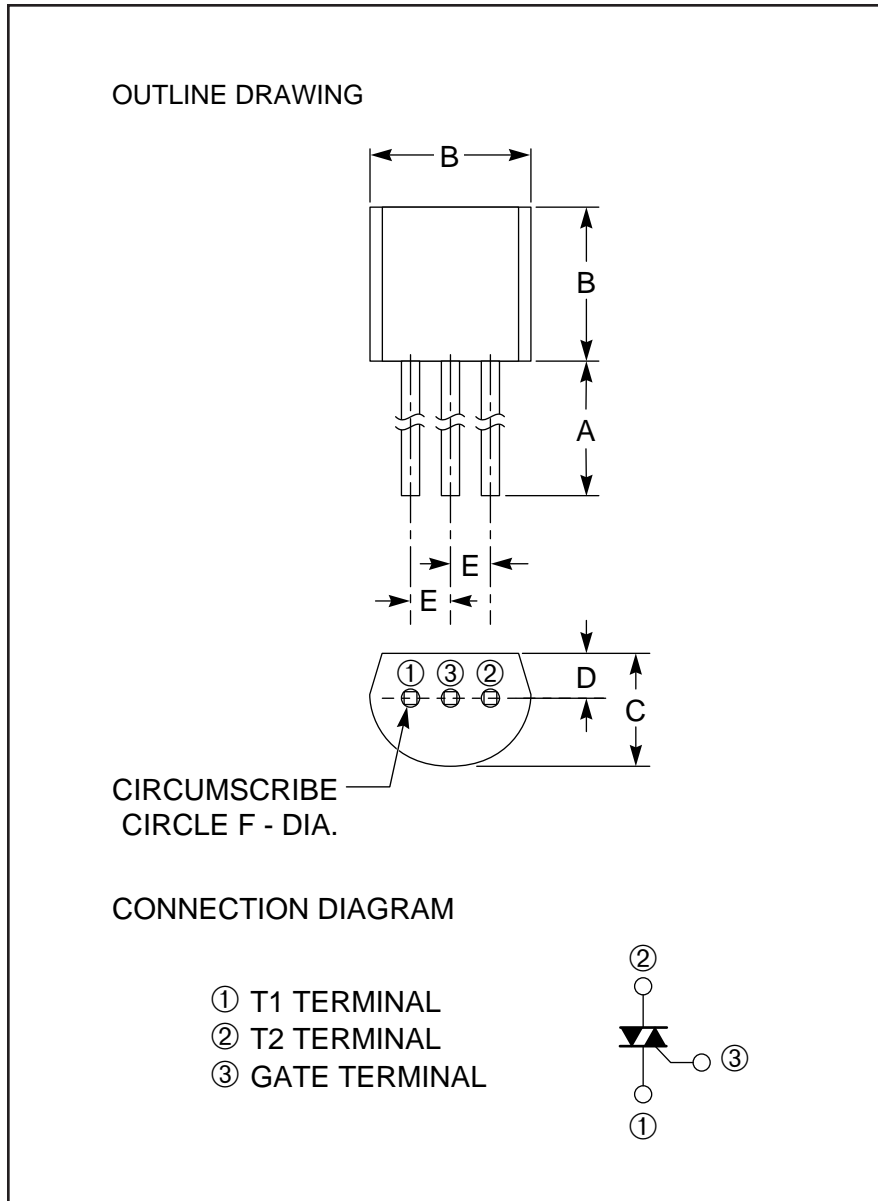

Outline Drawing (Conforms to JEDEC TO-92)

Dimensions	Inches	Millimeters
A	0.45 Min.	12.5 Min.
B	0.20 Max.	5.0 Max.
C	0.15 Max.	3.9 Max.
D	0.05	1.3
E	0.05	1.25
F	0.028 Dia.	0.7 Dia.

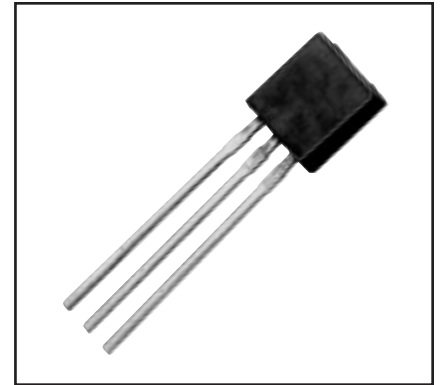

Description:

A triac is a solid state silicon AC switch which may be gate triggered from an off-state to an on-state for either polarity of applied voltage.

Features:

- Glass Passivation

Applications:

- AC Switch

Ordering Information:

Example: Select the complete seven or eight digit part number you desire from the table - i.e. BCR1AM-8 is a 400 Volt, 1 Ampere Triac.

Type	V _{DRM} Volts	Code
BCR1AM	400	-8
	600	-12



Powerex, Inc., 200 Hillis Street, Youngwood, Pennsylvania 15697-1800 (412) 925-7272

BCR1AM

Lead-Mount Triac

1 Ampere/400-600 Volts

Absolute Maximum Ratings, $T_a = 25\text{ }^\circ\text{C}$ unless otherwise specified

Ratings	Symbol	BCR1AM-8	BCR1AM-12	Units
Repetitive Peak Off-state Voltage (Gate Open)	V_{DRM}	400	600	Volts
Non-repetitive Peak Off-state Voltage (Gate Open)	V_{DSM}	500	720	Volts
On-state Current, $T_a = 56^\circ\text{C}$	$I_{T(RMS)}$	1	1	Amperes
Non-repetitive Peak Surge, One Cycle (60 Hz)	I_{TSM}	10	10	Amperes
Non-repetitive Peak Surge, One Cycle (50 Hz)	I_{TSM}	9.1	9.1	Amperes
I^2t for Fusing, $t = 8.3\text{ msec}$	I^2t	0.4	0.4	A^2sec
Peak Gate Power Dissipation, $20\text{ }\mu\text{sec}$	P_{GM}	1	1	Watts
Average Gate Power Dissipation	$P_{G(avg)}$	0.1	0.1	Watts
Peak Gate Current	I_{GM}	1	1	Amperes
Peak Gate Voltage	V_{GM}	6	6	Volts
Storage Temperature	T_{stg}	-40 to 125	-40 to 125	$^\circ\text{C}$
Operating Temperature	T_j	-40 to 125	-40 to 125	$^\circ\text{C}$
Weight	–	0.23	0.23	Grams

Electrical and Thermal Characteristics, $T_j = 25\text{ }^\circ\text{C}$ unless otherwise specified

Characteristics*	Symbol	Test Conditions (Trigger Mode)				BCR1AM			Units
		V_D	R_L	R_G	T_j	Min.	Typ.	Max.	
Gate – Parameters									
DC Gate Trigger Current									
MT2+ Gate+	I_{GT}	6V	6Ω	330Ω	25°C	–	–	5	mA
MT2+ Gate–		6V	6Ω	330Ω	25°C	–	–	5	mA
MT2– Gate–		6V	6Ω	330Ω	25°C	–	–	5	mA
MT2– Gate+		6V	6Ω	330Ω	25°C	–	–	10	mA
DC Gate Trigger Voltage									
MT2+ Gate+	V_{GT}	6V	6Ω	330Ω	25°C	–	–	2	Volts
MT2+ Gate–		6V	6Ω	330Ω	25°C	–	–	2	Volts
MT2– Gate–		6V	6Ω	330Ω	25°C	–	–	2	Volts
MT2– Gate+		6V	6Ω	330Ω	25°C	–	–	2	Volts
DC Gate Non-trigger Voltage									
All	V_{GD}	$1/2 V_{DRM}$	–	–	125°C	0.1	–	–	Volts

*Characteristic values apply for either polarity of Main Terminal 2 referenced to Main Terminal 1.

Characteristics	Symbol	Test Conditions	Min.	Typ.	Max.	Units
Thermal Resistance, Junction-to-case	$R_{th(j-c)}$	–	–	–	50	$^\circ\text{C/W}$
Steady State Thermal Resistance, Junction-to-ambient	$R_{th(j-a)}$	–	–	–	120	$^\circ\text{C/W}$
Voltage – Blocking State Repetitive Off-state Current	I_{DRM}	Gate Open Circuited, $V_D = V_{DRM}$, $T_j = 125^\circ\text{C}$	–	–	1	mA
Current – Conducting State Peak On-state Voltage	V_{TM}	$T_c = 25^\circ\text{C}$, 8.3ms Pulsewidth Duty Cycle <2%, $I_{TM} = 1.5\text{A}$	–	–	1.6	Volts
Critical Rate-of-Rise of Commutating Off-state Voltage (Commutating dv/dt) ▲ (Switching)	$(dv/dt)_c$	–	–	–	–	$\text{V}/\mu\text{s}$

BCR1AM

Lead-Mount Triac

1 Ampere/400-600 Volts

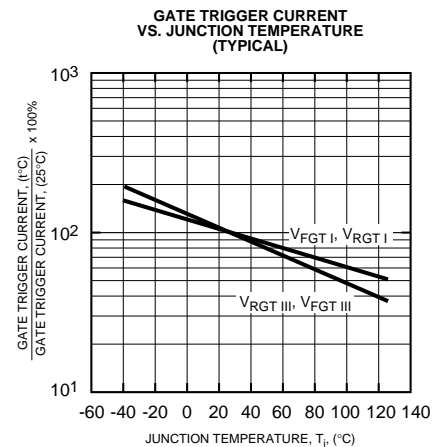
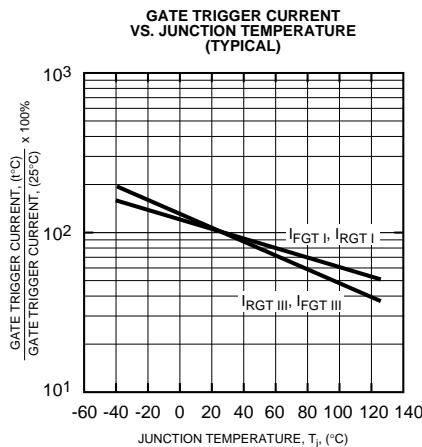
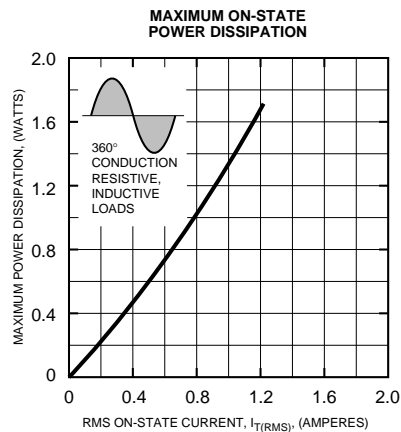
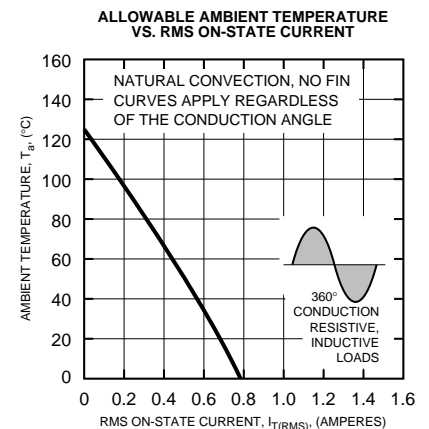
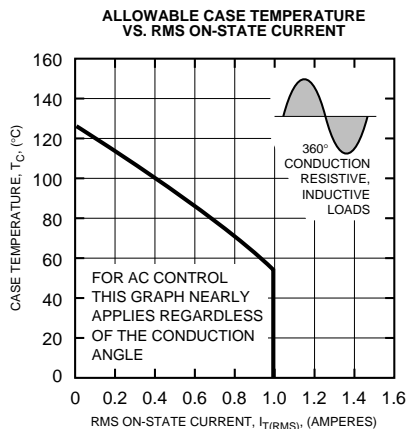
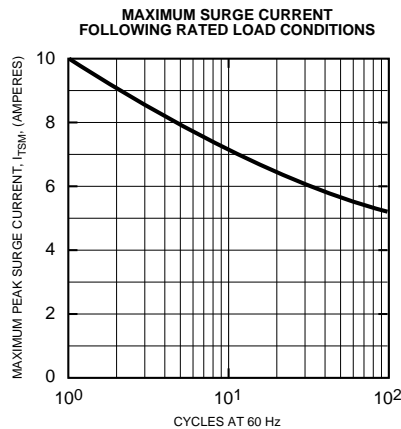
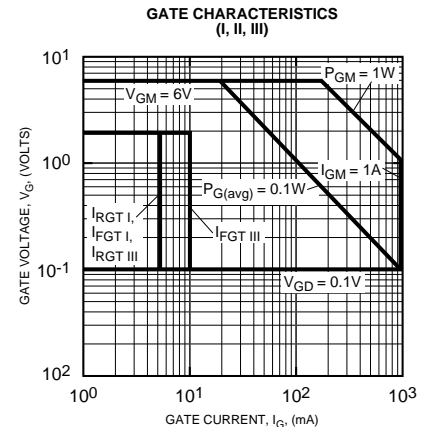
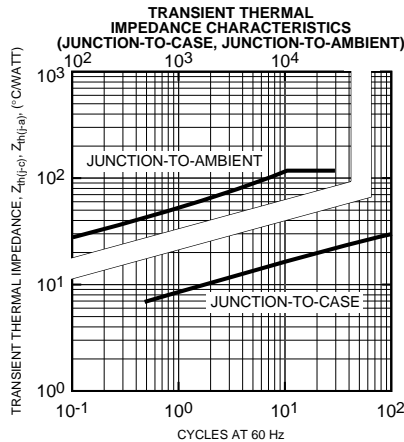
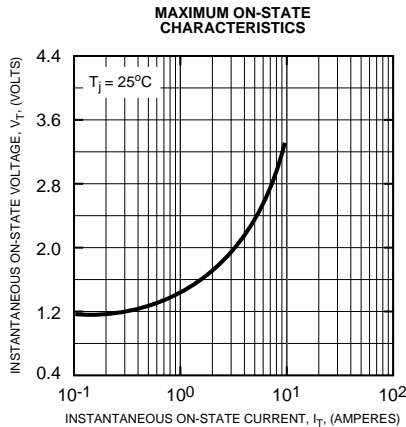

BCR1AM
Lead-Mount Triac
 1 Ampere/400-600 Volts

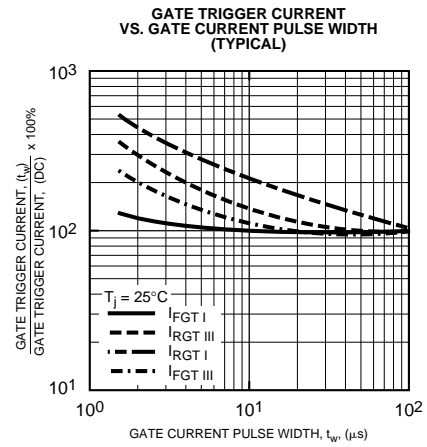
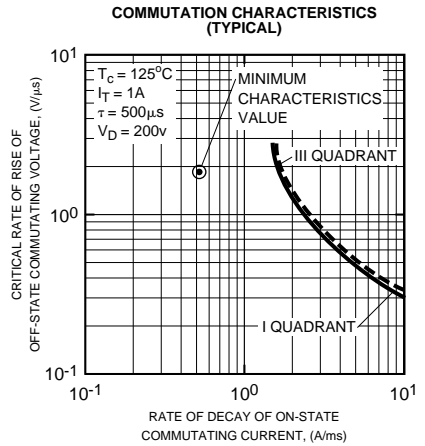
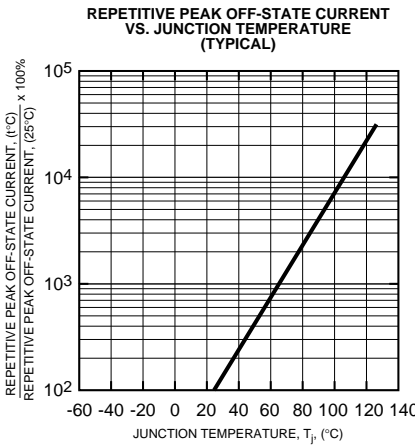
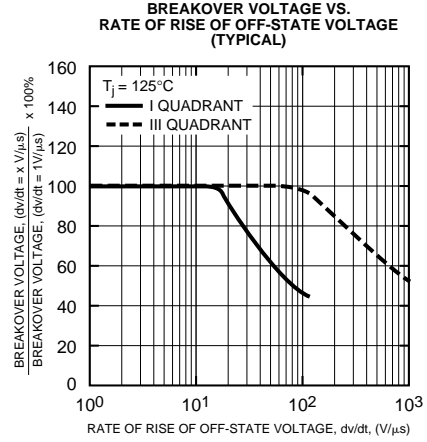
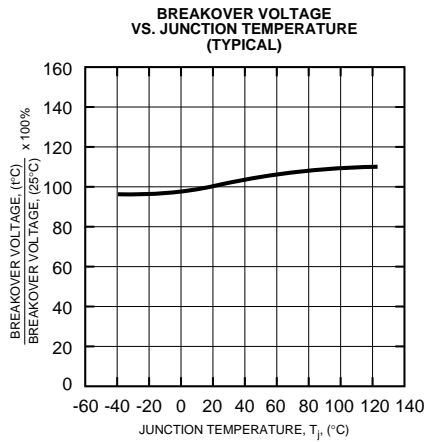
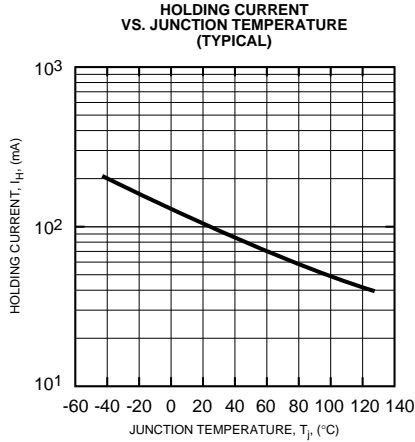

GATE TRIGGER CHARACTERISTICS TEST CIRCUITS

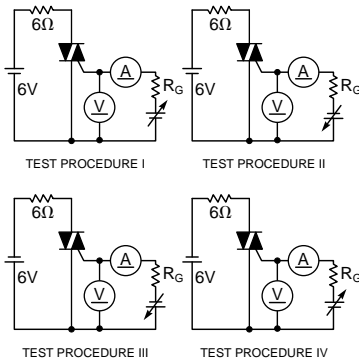

Δ Part Number	V _{DRM} (Volts)	Commutating dv/dt, (dv/dt) _c (V/μsec)		Test Condition	Commutating Voltage & Current Waveform (Inductive Load)
		Minimum	Value		
BCR1AM-8	400	2		T _j = 125°C, Rate of Decay On-state Commutating Current (di/dt) _c = -0.5A/msec, Peak Off-state Voltage V _D = 400V	
BCR1AM-12	600	2			



LittleDiode supplies new, hard to find or obsolete electronic components and semiconductors all over the world.

With over two million different components listed you are sure to find the part you need.

Feel free to visit us today at our online store:

LittleDiode.com

Looking forward to providing you with the best possible service.