

Isolated Triac 5 Amperes/400-600 Volts

OUTLINE DRAWING

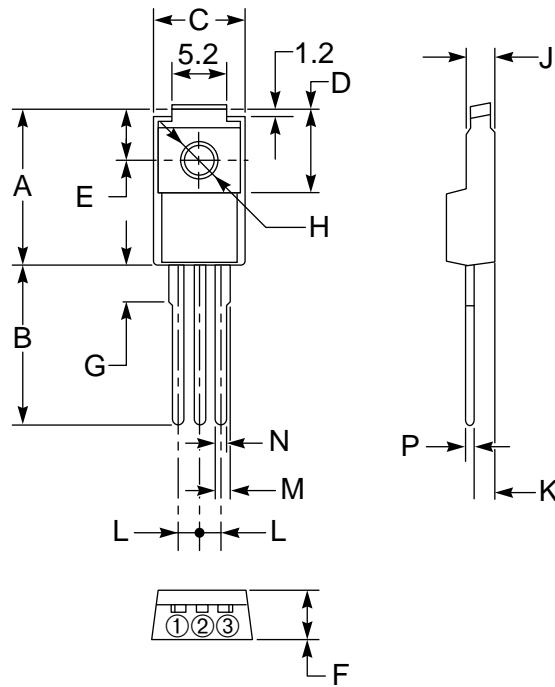

CONNECTION DIAGRAM

- ① T1 TERMINAL
- ② T2 TERMINAL
- ③ GATE TERMINAL

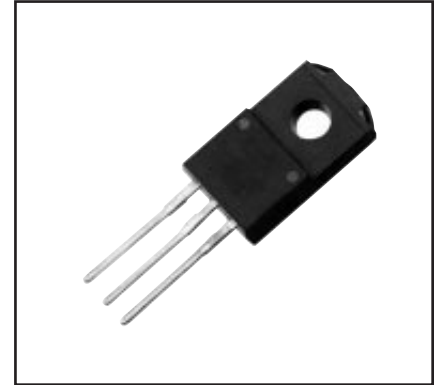
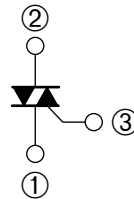

Description:

A triac is a solid state silicon AC switch which may be gate triggered from an off-state to an on-state for either polarity of applied voltage.

Features:

- Full Molded Isolation Package
- Glass Passivation
- 1500 V_{RMS} Isolation Voltage
UL Card
- Selected for Inductive Loads

Applications:

- AC Switch
- Motor Controls
- Lighting

Ordering Information:

Example: Select the complete seven, eight or nine digit part number you desire from the table - i.e. BCR5PM-8 is a 400 Volt, 5 Ampere Triac.

Outline Drawing (Conforms to TO-220F)

Dimensions	Inches	Millimeters
A	0.67	17.0
B	0.49 Min.	12.5 Min.
C	0.39	10.0
D	0.33	8.5
E	0.20	5.0
F	0.18	4.5
G	0.14	3.6

Dimensions	Inches	Millimeters
H	0.126 ± 0.008 Dia.	3.2 ± 0.2 Dia.
J	0.11	2.8
K	0.102	2.6
L	0.10	2.5
M	0.039	1.0
N	0.031	0.8
P	0.020	0.5

Type	V _{DRM} Volts	Code	Inductive Load*
BCR5PM	400	-8	L
	600	-12	

*For inductive load, add L.



Powerex, Inc., 200 Hillis Street, Youngwood, Pennsylvania 15697-1800 (412) 925-7272

BCR5PM

Isolated Triac

5 Amperes/400-600 Volts

Absolute Maximum Ratings, $T_a = 25\text{ }^\circ\text{C}$ unless otherwise specified

Ratings	Symbol	BCR5PM-8	BCR5PM-12	Units
Repetitive Peak Off-state Voltage	V_{DRM}	400	600	Volts
Non-repetitive Peak Off-state Voltage	V_{DSM}	500	720	Volts
On-state Current, $T_c = 95^\circ\text{C}$	$I_{T(RMS)}$	5	5	Amperes
Non-repetitive Peak Surge, One Cycle (60 Hz)	I_{TSM}	50	50	Amperes
I^2t for Fusing, $t = 8.3\text{ msec}$	I^2t	10.4	10.4	A^2sec
Peak Gate Power Dissipation, 20 μsec	P_{GM}	3	3	Watts
Average Gate Power Dissipation	$P_{G(avg)}$	0.3	0.3	Watts
Peak Gate Current	I_{GM}	2	2	Amperes
Peak Gate Voltage	V_{GM}	10	10	Volts
Storage Temperature	T_{stg}	-40 to 125	-40 to 125	$^\circ\text{C}$
Operating Junction Temperature	T_j	-40 to 125	-40 to 125	$^\circ\text{C}$
Isolation Voltage applied for one minute, terminal-to-case	V_{iso}	1500	1500	Volts
Weight	–	2	2	Grams



Powerex, Inc., 200 Hillis Street, Youngwood, Pennsylvania 15697-1800 (412) 925-7272

BCR5PM
Isolated Triac
 5 Amperes/400-600 Volts

Electrical and Thermal Characteristics, $T_j = 25\text{ }^\circ\text{C}$ unless otherwise specified

Characteristics	Symbol	Test Conditions (Trigger Mode)			BCR5PM			Units
		V_D	R_L	T_j	Min.	Typ.	Max.	
Gate Parameters								
DC Gate Trigger Current								
MT2+ Gate+	I_{GT}	6V	6 Ω	25 $^\circ\text{C}$	–	–	20	mA
MT2+ Gate–		6V	6 Ω	25 $^\circ\text{C}$	–	–	20	mA
MT2– Gate–		6V	6 Ω	25 $^\circ\text{C}$	–	–	20	mA
DC Gate Trigger Voltage								
MT2+ Gate+	V_{GT}	6V	6 Ω	25 $^\circ\text{C}$	–	–	1.5	Volts
MT2+ Gate–		6V	6 Ω	25 $^\circ\text{C}$	–	–	1.5	Volts
MT2– Gate–		6V	6 Ω	25 $^\circ\text{C}$	–	–	1.5	Volts
DC Gate Non-trigger Voltage								
All	V_{GD}	1/2 V_{DRM}	–	125 $^\circ\text{C}$	0.2	–	–	Volts

BCR5PM

Isolated Triac

5 Amperes/400-600 Volts

Electrical and Thermal Characteristics, $T_j = 25^\circ\text{C}$ unless otherwise specified

Characteristics	Symbol	Test Conditions	Min.	Typ.	Max.	Units
Thermal Resistance, Junction-to-case	$R_{th(j-c)}$	–	–	–	4	$^\circ\text{C/W}$
Steady State Thermal Resistance, Junction-to-ambient	$R_{th(j-a)}$	–	–	–	60	$^\circ\text{C/W}$
Voltage – Blocking State Repetitive Off-state Current	I_{DRM}	Gate Open Circuited, $V_D = V_{DRM}$, $T_j = 125^\circ\text{C}$	–	–	2	mA
Current – Conducting State Peak On-state Voltage	V_{TM}	$T_C = 25^\circ\text{C}$, 8.3ms Pulsewidth Duty Cycle <2%, $I_{TM} = 7\text{A}$ Peak	–	–	1.8	Volts
DC Holding Current	I_H	Main Terminal Source Voltage = 75Vdc, Peak Initiating On-state Current = 1A, $T_j = 25^\circ\text{C}$	–	30	–	MA
Critical Rate-of-rise of Commutating Off-state Voltage (Commutating dv/dt) ▲ for inductive load (L) (Switching)	$(dv/dt)_c$	–	–	–	–	$\text{V}/\mu\text{s}$

Δ Part Number	V_{DRM} (Volts)	Load Type	Commutating $dv/dt, (dv/dt)_c$ ($\text{V}/\mu\text{sec}$)		Test Condition	Commutating Voltage & Current Waveform (Inductive Load)
			Minimum			
BCR5PM-8L	400	L	5		$T_j = 125^\circ\text{C}$,	
BCR5PM-12L	600	L	5		Rate of Decay On-state Commutating Current $(di/dt)_c = -2.5\text{A/msec}$; Peak Off-state Voltage $V_D = 400\text{V}$	

BCR5PM

Isolated Triac

5 Amperes/400-600 Volts

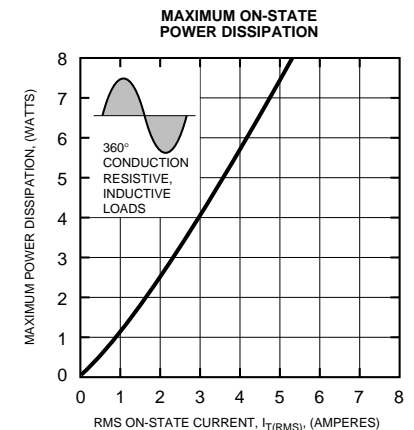
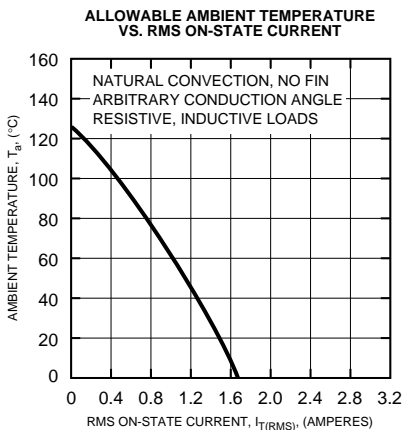
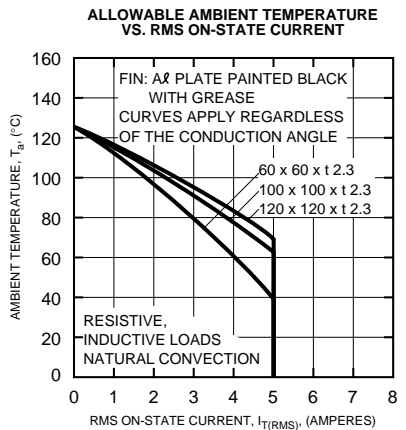
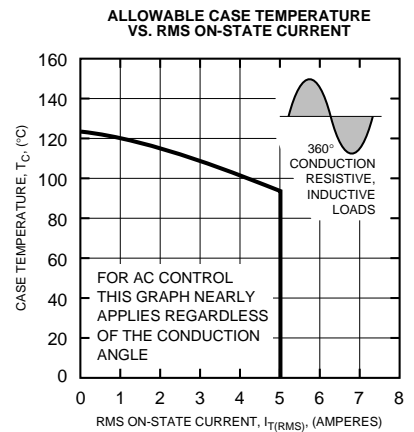
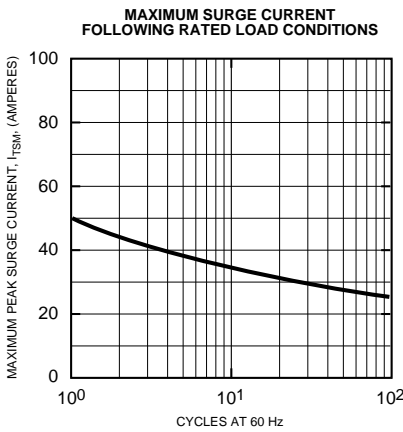
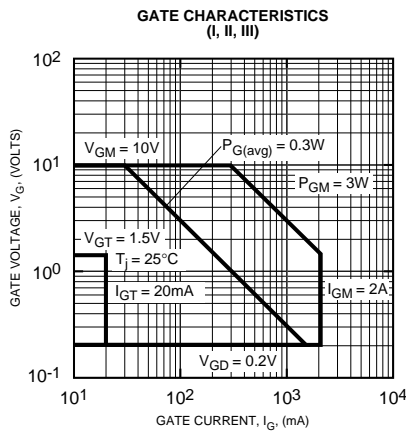
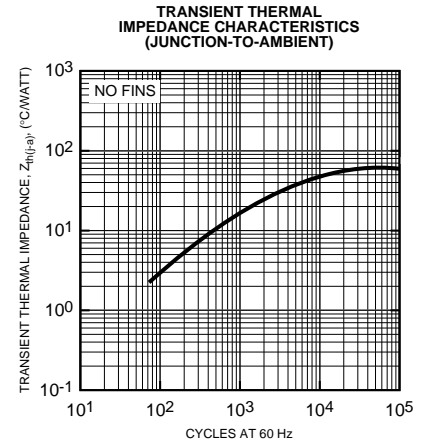
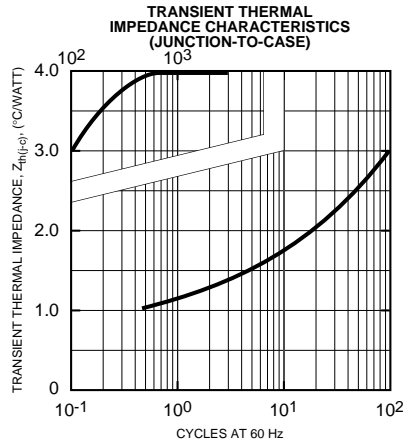
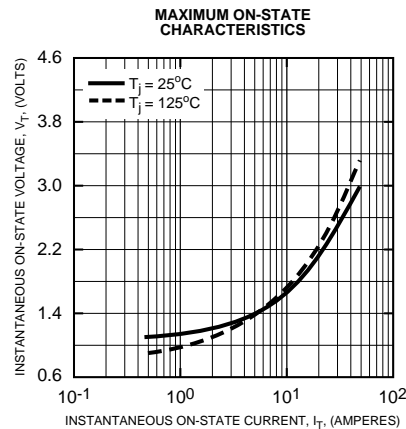

BCR5PM
Isolated Triac
 5 Amperes/400-600 Volts

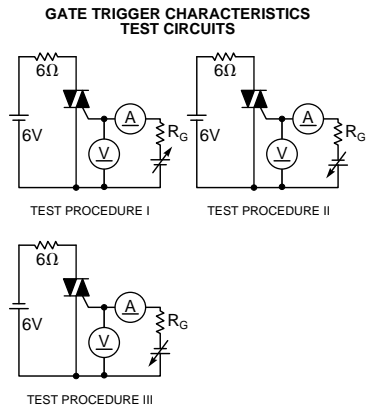
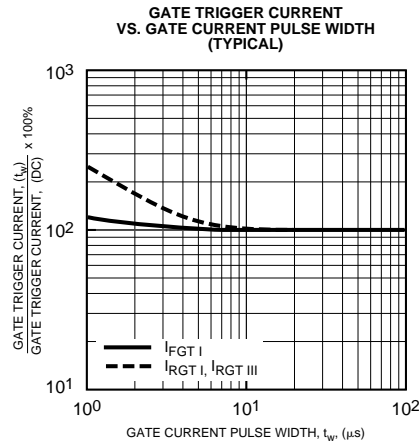
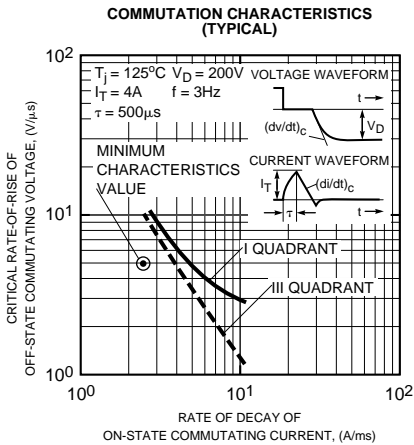
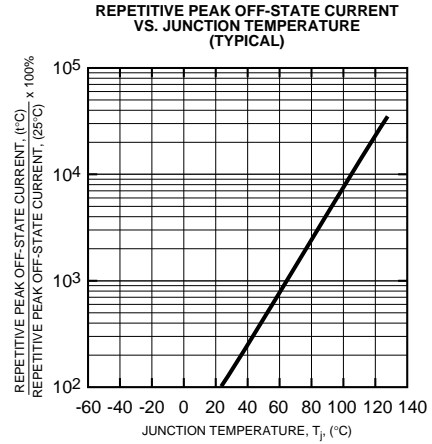
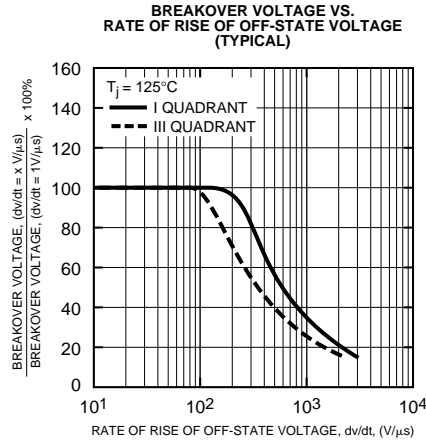
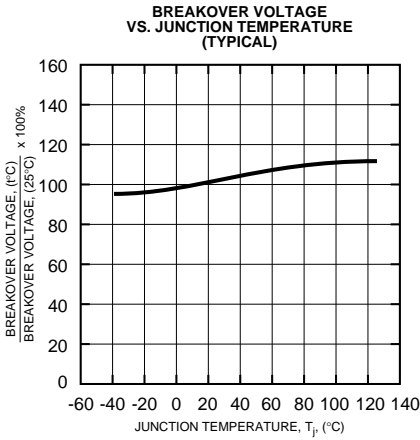
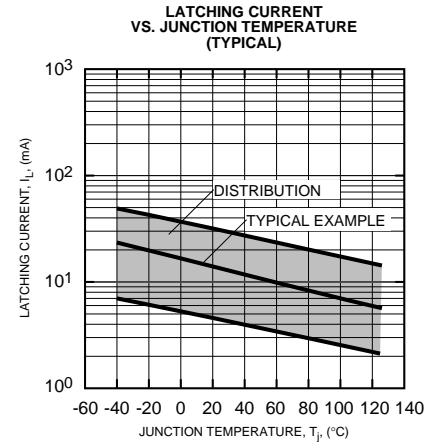
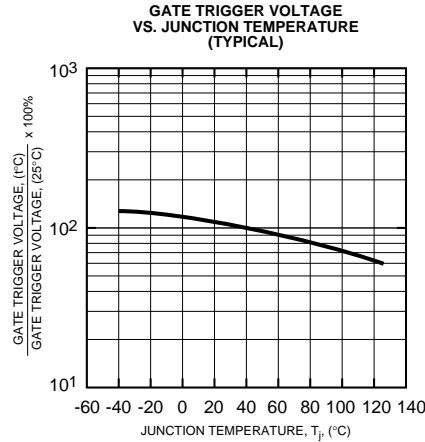
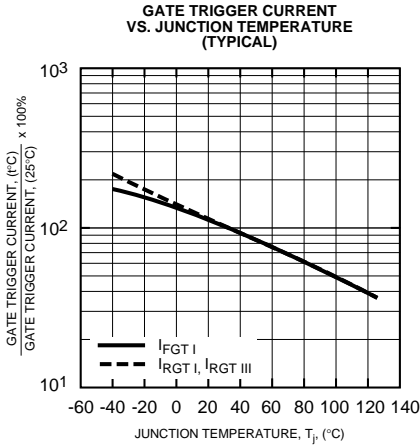



LittleDiode supplies new, hard to find or obsolete electronic components and semiconductors all over the world.

With over two million different components listed you are sure to find the part you need.

Feel free to visit us today at our online store:

LittleDiode.com

Looking forward to providing you with the best possible service.