

### Silicon N Channel MOSFET Tetrode

#### Target data sheet

- Short-channel transistor with high S/C quality factor
- For low-noise, gain-controlled input stages up to 1 GHz

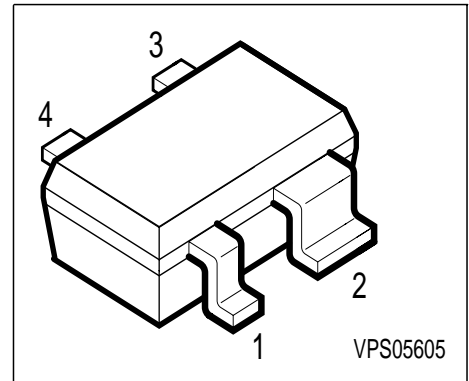

Type	Marking	Ordering Code	Pin Configuration				Package
BF 2000W	NDs	Q62702-F1772	1 = D	2 = S	3 = G1	4 = G2	SOT-343

#### Maximum Ratings

Parameter	Symbol	Value	Unit
Drain-source voltage	$V_{DS}$	12	V
Continuous drain current	$I_D$	30	mA
Gate 1/gate 2 peak source current	$\pm I_{G1/2SM}$	10	
Total power dissipation, $T_S = 76^\circ\text{C}$	$P_{tot}$	200	mW
Storage temperature	$T_{stg}$	- 55 ... +150	$^\circ\text{C}$
Channel temperature	$T_{ch}$	150	

#### Thermal Resistance

Channel - soldering point	$R_{thchs}$	$\leq 280$	K/W
---------------------------	-------------	------------	-----

**Electrical Characteristics** at  $T_A = 25\text{ °C}$ ; unless otherwise specified.

Parameter	Symbol	Values			Unit
		min.	typ.	max.	
<b>DC characteristics</b>					
Drain-source breakdown voltage $I_D = 10\text{ }\mu\text{A}$ , $-V_{G1S} = 4\text{ V}$ , $-V_{G2S} = 4\text{ V}$	$V_{(BR)DS}$	12	-	-	V
Gate 1 source breakdown voltage $\pm I_{G1S} = 10\text{ mA}$ , $V_{G2S} = V_{DS} = 0$	$\pm V_{(BR)G1SS}$	8	-	12	
Gate 2 source breakdown voltage $\pm I_{G2S} = 10\text{ mA}$ , $V_{G1S} = 0\text{ V}$ , $V_{DS} = 0\text{ V}$	$\pm V_{(BR)G2SS}$	8	-	12	
Gate 1 source leakage current $\pm V_{G1S} = 5\text{ V}$ , $V_{G2S} = V_{DS} = 0$	$\pm I_{G1SS}$	-	-	50	nA
Gate 2 source leakage current $\pm V_{G2S} = 5\text{ V}$ , $V_{G1S} = 0\text{ V}$ , $V_{DS} = 0\text{ V}$	$\pm I_{G2SS}$	-	-	50	
Drain current $V_{DS} = 5\text{ V}$ , $V_{G1S} = 0$ , $V_{G2S} = 4\text{ V}$	$I_{DSS}$	-	-	1	$\mu\text{A}$
Gate 1-source pinch-off voltage $V_{DS} = 5\text{ V}$ , $V_{G2S} = 4\text{ V}$ , $I_D = 200\text{ }\mu\text{A}$	$V_{G1S(p)}$	-	0.3	-	V
Gate 2-source pinch-off voltage $V_{DS} = 5\text{ V}$ , $I_D = 100\text{ }\mu\text{A}$	$V_{G2S(p)}$	-	0.2	-	

**Electrical Characteristics** at  $T_A = 25\text{ °C}$ , unless otherwise specified.

Parameter	Symbol	Values			Unit
		min.	typ.	max.	
<b>AC characteristics</b>					
Forward transconductance $V_{DS} = 5\text{ V}$ , $I_D = 10\text{ mA}$ , $V_{G2S} = 4\text{ V}$ , $f = 1\text{ kHz}$	$g_{fs}$	-	24	-	mS
Gate 1 input capacitance $V_{DS} = 5\text{ V}$ , $I_D = 10\text{ mA}$ , $V_{G2S} = 4\text{ V}$ , $f = 1\text{ MHz}$	$C_{g1ss}$	-	1.2	-	pF
Gate 2 input capacitance $V_{DS} = 5\text{ V}$ , $I_D = 10\text{ mA}$ , $V_{G2S} = 4\text{ V}$ , $f = 1\text{ MHz}$	$C_{g2ss}$	-	-	-	
Feedback capacitance $V_{DS} = 8\text{ V}$ , $I_D = 10\text{ mA}$ , $V_{G2S} = 4\text{ V}$ , $f = 1\text{ MHz}$	$C_{dg1}$	-	25	-	fF
Output capacitance $V_{DS} = 5\text{ V}$ , $I_D = 10\text{ mA}$ , $V_{G2S} = 4\text{ V}$ , $f = 1\text{ MHz}$	$C_{dss}$	-	0.8	-	pF
Power gain $V_{DS} = 5\text{ V}$ , $I_D = 10\text{ mA}$ , $V_{G2S} = 4\text{ V}$ , $f = 45\text{ MHz}$	$G_{ps}$	28	29	-	dB
Power gain $V_{DS} = 5\text{ V}$ , $I_D = 10\text{ mA}$ , $V_{G2S} = 4\text{ V}$ , $f = 800\text{ MHz}$	$G_{ps}$	-	22	-	
Noise figure $V_{DS} = 5\text{ V}$ , $I_D = 10\text{ mA}$ , $V_{G2S} = 4\text{ V}$ , $f = 45\text{ MHz}$	$F$	-	1.1	-	
Noise figure $V_{DS} = 5\text{ V}$ , $I_D = 10\text{ mA}$ , $V_{G2S} = 4\text{ V}$ , $f = 800\text{ MHz}$	$F$	-	1	-	
Gain control range $V_{DS} = 8\text{ V}$ , $V_{G2S} = 4 \dots -2\text{ V}$ , $f = 800\text{ MHz}$	$\Delta G_{ps}$	40	-	-	



LittleDiode supplies new, hard to find or obsolete electronic components and semiconductors all over the world.

With over two million different components listed you are sure to find the part you need.

Feel free to visit us today at our online store:

[LittleDiode.com](http://LittleDiode.com)

Looking forward to providing you with the best possible service.