

**NPN Silicon RF Transistor**

- For amplifier and oscillator applications in TV-tuners

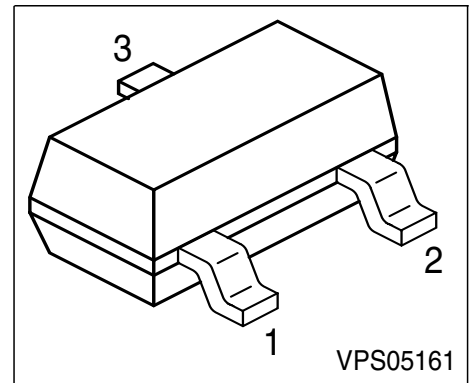

Type	Marking	Pin Configuration			Package
BF 517	LRs	1 = B	2 = E	3 = C	SOT-23

**Maximum Ratings**

Parameter	Symbol	Value	Unit
Collector-emitter voltage	$V_{CEO}$	15	V
Collector-base voltage	$V_{CBO}$	20	
Emitter-base voltage	$V_{EBO}$	2.5	
Collector current	$I_C$	25	mA
Peak collector current, $f \geq 10$ MHz	$I_{CM}$	50	
Total power dissipation, $T_S \leq 55$ °C <sup>F)</sup>	$P_{tot}$	280	mW
Junction temperature	$T_j$	150	°C
Ambient temperature	$T_A$	-65 ... 150	
Storage temperature	$T_{stg}$	-65 ... 150	

**Thermal Resistance**

Junction - soldering point	$R_{thJS}$	$\leq 340$	K/W
----------------------------	------------	------------	-----

<sup>1</sup> $T_S$  is measured on the collector lead at the soldering point to the pcb

**Electrical Characteristics** at  $T_A = 25\text{ }^\circ\text{C}$ , unless otherwise specified.

Parameter	Symbol	Values			Unit
		min.	typ.	max.	
<b>DC characteristics</b>					
Collector-emitter breakdown voltage $I_C = 1\text{ mA}, I_B = 0$	$V_{(BR)CEO}$	15	-	-	V
Collector-base cutoff current $V_{CB} = 15\text{ V}, I_E = 0$	$I_{CBO}$	-	-	50	nA
DC current gain $I_C = 5\text{ mA}, V_{CE} = 10\text{ V}$	$h_{FE}$	25	-	250	-
Collector-emitter saturation voltage $I_C = 10\text{ mA}, I_B = 1\text{ mA}$	$V_{CEsat}$	-	0.1	0.5	V
<b>AC characteristics</b>					
Transition frequency $I_C = 5\text{ mA}, V_{CE} = 10\text{ V}, f = 200\text{ MHz}$	$f_T$	1	2	-	GHz
Collector-base capacitance $V_{CB} = 5\text{ V}, f = 1\text{ MHz}$	$C_{cb}$	0.3	0.55	0.75	pF
Collector-emitter capacitance $V_{CE} = 5\text{ V}, f = 1\text{ MHz}$	$C_{ce}$	-	0.25	0.4	
Input capacitance $V_{EB} = 0.5\text{ V}, I_C = 0, f = 1\text{ MHz}$	$C_{ibo}$	-	1.45	-	
Output capacitance $V_{CE} = 5\text{ V}, V_{BE} = 0, f = 1\text{ MHz}$	$C_{obs}$	-	0.8	-	
Noise figure $I_C = 5\text{ mA}, V_{CE} = 10\text{ V}, f = 100\text{ MHz},$ $Z_S = 75\text{ }\Omega$	$F$	-	2.5	-	

**Total power dissipation  $P_{tot} = f(T_A^*, T_S)$**

\* Package mounted on epoxy

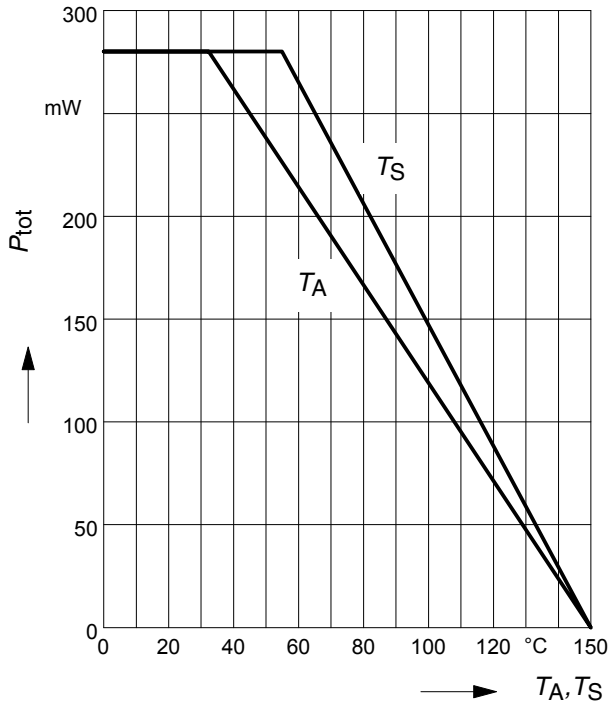

**Permissible Pulse Load  $R_{thJS} = f(t_p)$**

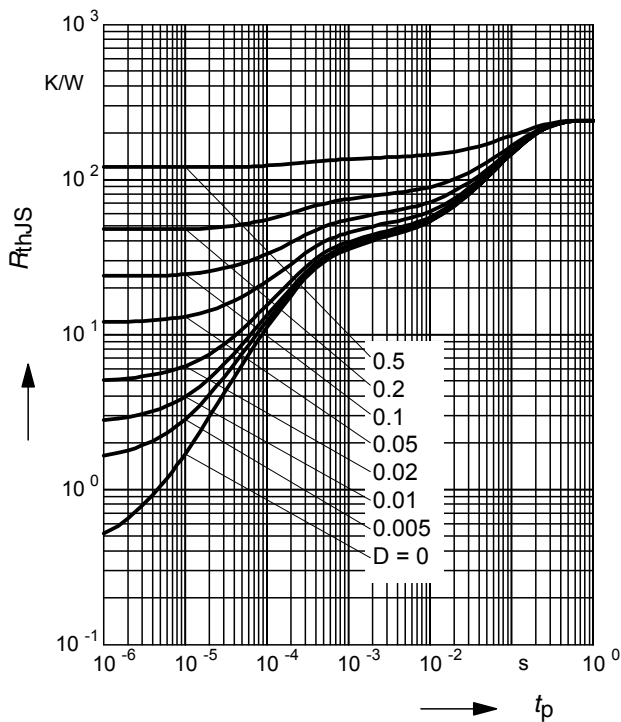

**Permissible Pulse Load**

$P_{totmax}/P_{totDC} = f(t_p)$

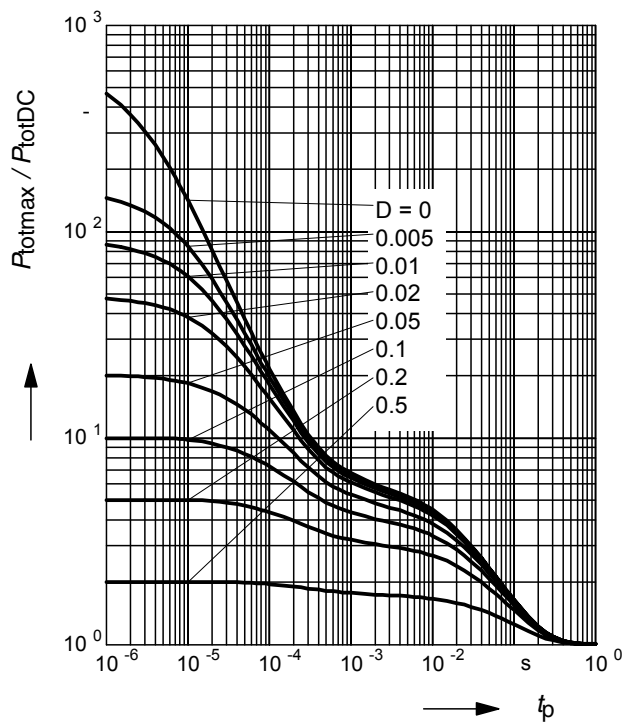

**Collector-base capacitance**  $C_{cb} = f(V_{CB})$   
 $f = 1\text{MHz}$

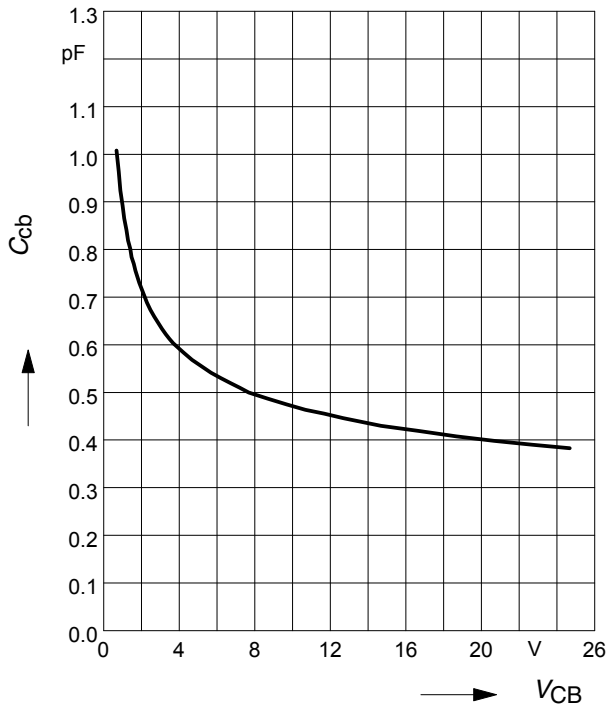

**Transition frequency**  $f_T = f(I_C)$

$V_{CE} = \text{Parameter}$

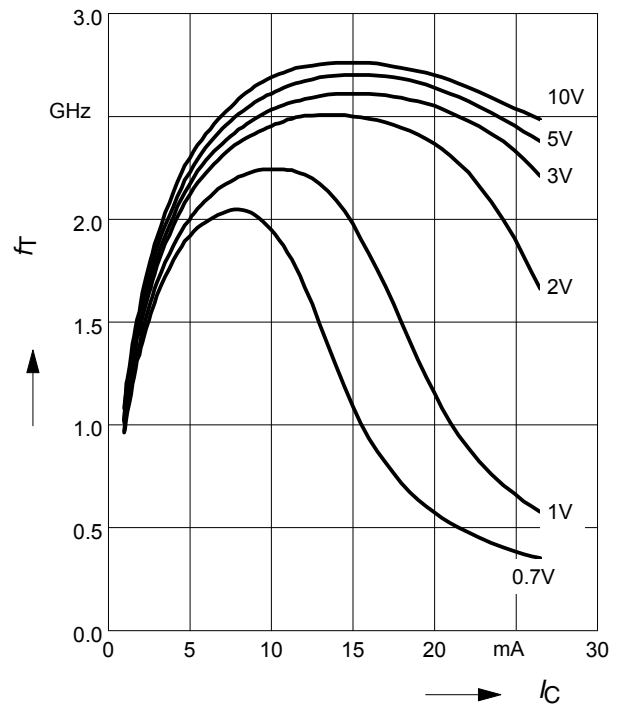



LittleDiode supplies new, hard to find or obsolete electronic components and semiconductors all over the world.

With over two million different components listed you are sure to find the part you need.

Feel free to visit us today at our online store:

[LittleDiode.com](http://LittleDiode.com)

Looking forward to providing you with the best possible service.