

NPN Silicon RF Transistor

- For low-power amplifiers in mobile communication systems (pager) at collector currents from 0.2 mA to 2.5 mA
 $f_T = 7 \text{ GHz}$
- $F = 2.1 \text{ dB}$ at 900 MHz

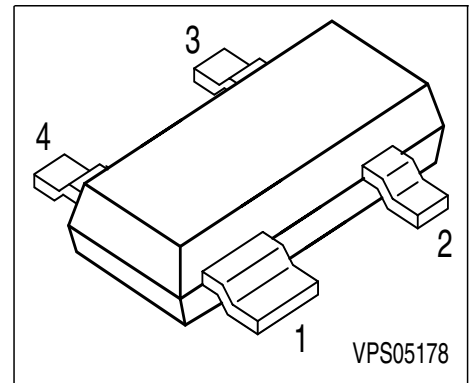

ESD: Electrostatic discharge sensitive device, observe handling precaution!

| Type | Marking | Pin Configuration | | | | Package |
|---------|---------|-------------------|-------|-------|-------|---------|
| BFP 180 | RDs | 1 = C | 2 = E | 3 = B | 4 = E | SOT-143 |

Maximum Ratings

| Parameter | Symbol | Value | Unit |
|---|-----------|-------------|------|
| Collector-emitter voltage | V_{CEO} | 8 | V |
| Collector-emitter voltage | V_{CES} | 10 | |
| Collector-base voltage | V_{CBO} | 10 | |
| Emitter-base voltage | V_{EBO} | 2 | |
| Collector current | I_C | 4 | mA |
| Base current | I_B | 0.5 | |
| Total power dissipation, $T_S \leq 124^\circ\text{C}$ ¹⁾ | P_{tot} | 30 | mW |
| Junction temperature | T_j | 150 | °C |
| Ambient temperature | T_A | -65 ... 150 | |
| Storage temperature | T_{stg} | -65 ... 150 | |

Thermal Resistance

| | | | |
|----------------------------|------------|------------|-----|
| Junction - soldering point | R_{thJS} | ≤ 875 | K/W |
|----------------------------|------------|------------|-----|

¹⁾ T_S is measured on the collector lead at the soldering point to the pcb

Electrical Characteristics at $T_A = 25^\circ\text{C}$, unless otherwise specified.

| Parameter | Symbol | Values | | | Unit |
|--|---------------|--------|------|------|---------------|
| | | min. | typ. | max. | |
| DC characteristics | | | | | |
| Collector-emitter breakdown voltage $I_C = 1\text{ mA}, I_B = 0$ | $V_{(BR)CEO}$ | 8 | - | - | V |
| Collector-emitter cutoff current $V_{CE} = 10\text{ V}, V_{BE} = 0$ | I_{CES} | - | - | 100 | μA |
| Collector-base cutoff current $V_{CB} = 8\text{ V}, I_E = 0$ | I_{CBO} | - | - | 100 | nA |
| Emitter-base cutoff current $V_{EB} = 1\text{ V}, I_C = 0$ | I_{EBO} | - | - | 1 | μA |
| DC current gain $I_C = 1\text{ mA}, V_{CE} = 5\text{ V}$ | h_{FE} | 30 | 100 | 200 | - |

Electrical Characteristics at $T_A = 25^\circ\text{C}$, unless otherwise specified.

| Parameter | Symbol | Values | | | Unit |
|---|---------------|--------|-------------|------|------|
| | | min. | typ. | max. | |
| AC characteristics (verified by random sampling) | | | | | |
| Transition frequency $I_C = 3 \text{ mA}$, $V_{CE} = 5 \text{ V}$, $f = 500 \text{ MHz}$ | f_T | 5 | 7 | - | GHz |
| Collector-base capacitance $V_{CB} = 5 \text{ V}$, $f = 1 \text{ MHz}$ | C_{cb} | - | 0.19 | 0.35 | pF |
| Collector-emitter capacitance $V_{CE} = 5 \text{ V}$, $f = 1 \text{ MHz}$ | C_{ce} | - | 0.27 | - | |
| Emitter-base capacitance $V_{EB} = 0.5 \text{ V}$, $f = 1 \text{ MHz}$ | C_{eb} | - | 0.13 | - | |
| Noise figure $I_C = 1 \text{ mA}$, $V_{CE} = 5 \text{ V}$, $Z_S = Z_{Sopt}$, $f = 900 \text{ MHz}$ $f = 1.8 \text{ GHz}$ | F | - | 2.1 2.25 | - | dB |
| Power gain, maximum stable ^{F)} $I_C = 1 \text{ mA}$, $V_{CE} = 5 \text{ V}$, $Z_S = Z_{Sopt}$, $Z_L = Z_{Lopt}$, $f = 900 \text{ MHz}$ $f = 1.8 \text{ GHz}$ | G_{ms} | - | 15 12 | - | |
| Transducer gain $I_C = 1 \text{ mA}$, $V_{CE} = 5 \text{ V}$, $Z_S = Z_L = 50\Omega$, $f = 900 \text{ MHz}$ $f = 1.8 \text{ GHz}$ | $ S_{21e} ^2$ | - | 8.5 7 | - | |

$$^1G_{ms} = |S_{21} / S_{12}|$$

SPICE Parameters (Gummel-Poon Model, Berkley-SPICE 2G.6 Syntax) :

Transistor Chip Data

| | | | | | | | | |
|-------|---------|----------|-------|----------|----------|--------|---------|----------|
| IS = | 0.18519 | fA | BF = | 94.687 | - | NF = | 1.0236 | - |
| VAF = | 26.867 | V | IKF = | 0.025252 | A | ISE = | 130.93 | fA |
| NE = | 1.9818 | - | BR = | 20.325 | - | NR = | 0.93013 | - |
| VAR = | 3.2134 | V | IKR = | 0.012138 | A | ISC = | 6.1852 | fA |
| NC = | 1.6195 | - | RB = | 1.4255 | Ω | IRB = | 0.01 | mA |
| RBM = | 60 | Ω | RE = | 3.7045 | Ω | RC = | 0.56 | Ω |
| CJE = | 3.2473 | fF | VJE = | 1.1812 | V | MJE = | 0.41827 | - |
| TF = | 14.866 | ps | XTF = | 0.3062 | - | VTF = | 0.22023 | V |
| ITF = | 1.0202 | mA | PTF = | 0 | deg | CJC = | 183.69 | fF |
| VJC = | 1.1812 | V | MJC = | 0.30423 | - | XCJC = | 0.08334 | - |
| TR = | 2.2648 | ns | CJS = | 0 | fF | VJS = | 0.75 | V |
| MJS = | 0 | - | XTB = | 0 | - | EG = | 1.11 | eV |
| XTI = | 3 | - | FC = | 0.87906 | - | TNOM | 300 | K |

All parameters are ready to use, no scaling is necessary.
 Extracted on behalf of SIEMENS Small Signal Semiconductors by:
 Institut für Mobil-und Satellitentechnik (IMST)
 © 1996 SIEMENS AG

Package Equivalent Circuit:

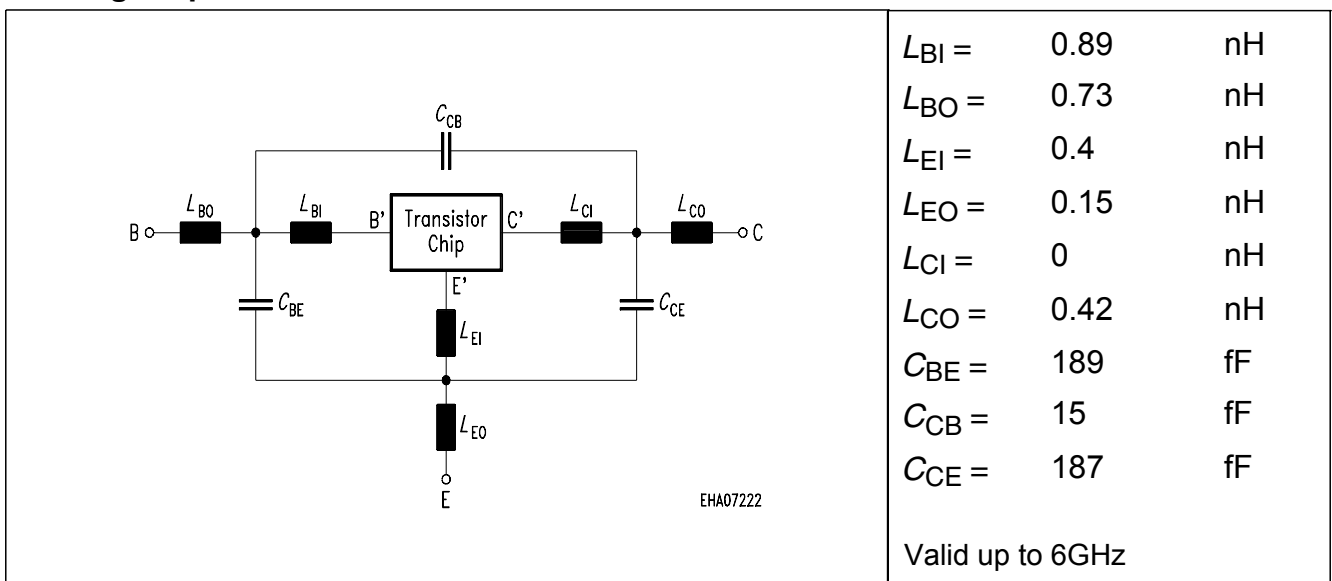

For examples and ready to use parameters please contact your local Infineon Technologies distributor or sales office to obtain a Infineon Technologies CD-ROM or see Internet: <http://www.infineon.com/products/discrete/index.htm>

Total power dissipation $P_{tot} = f(T_A^*, T_S)$

* Package mounted on epoxy

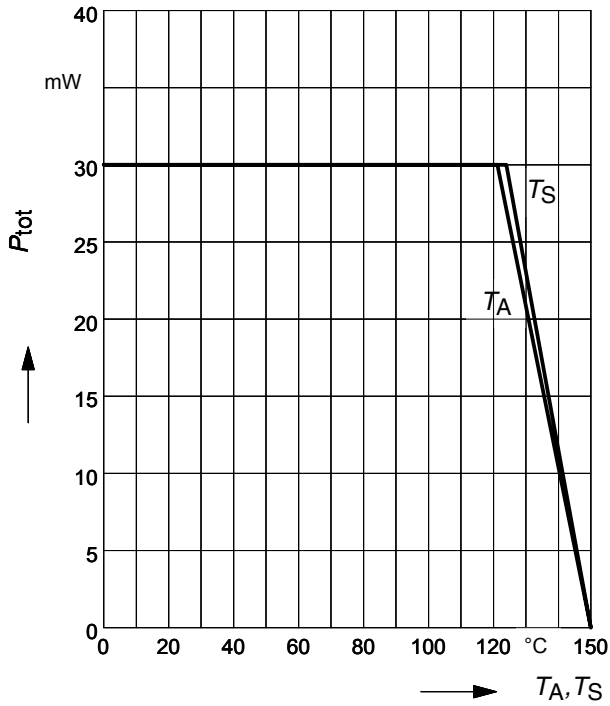

Permissible Pulse Load $R_{thJS} = f(t_p)$

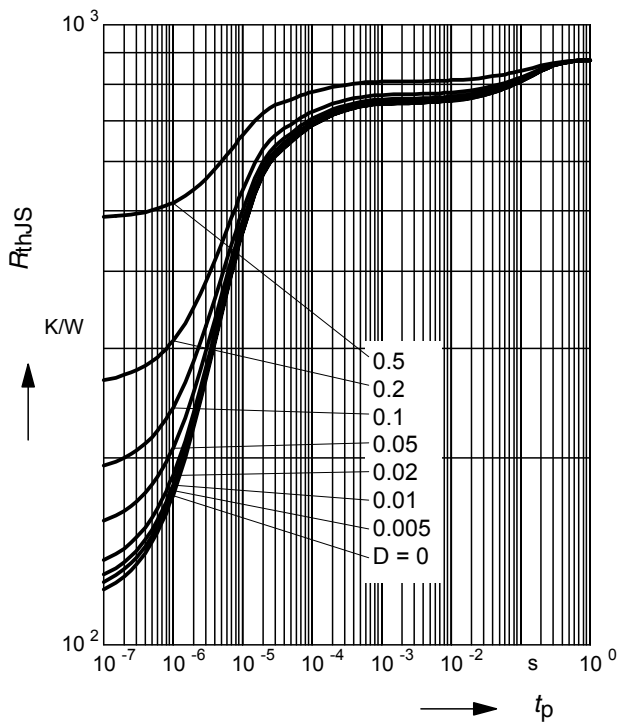

Permissible Pulse Load

$P_{totmax}/P_{totDC} = f(t_p)$

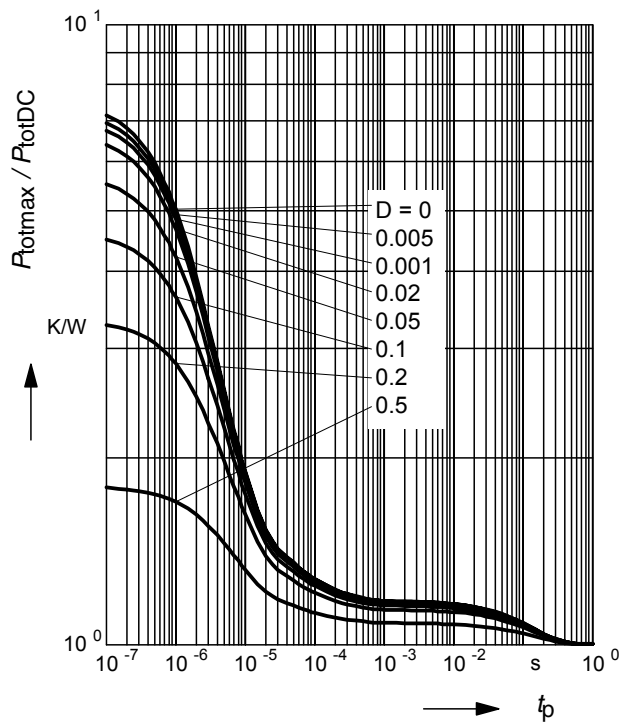

Collector-base capacitance $C_{cb} = f(V_{CB})$

$f = 1\text{MHz}$

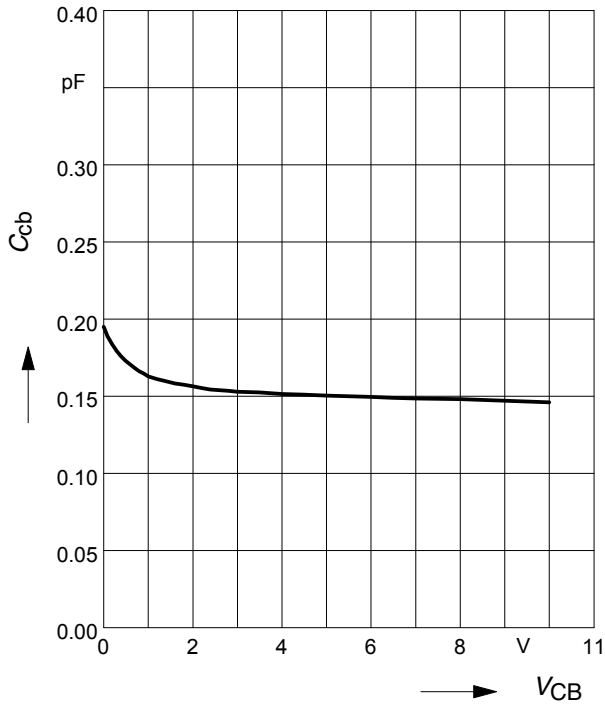

Transition frequency $f_T = f(I_C)$

$V_{CE} = \text{Parameter}$

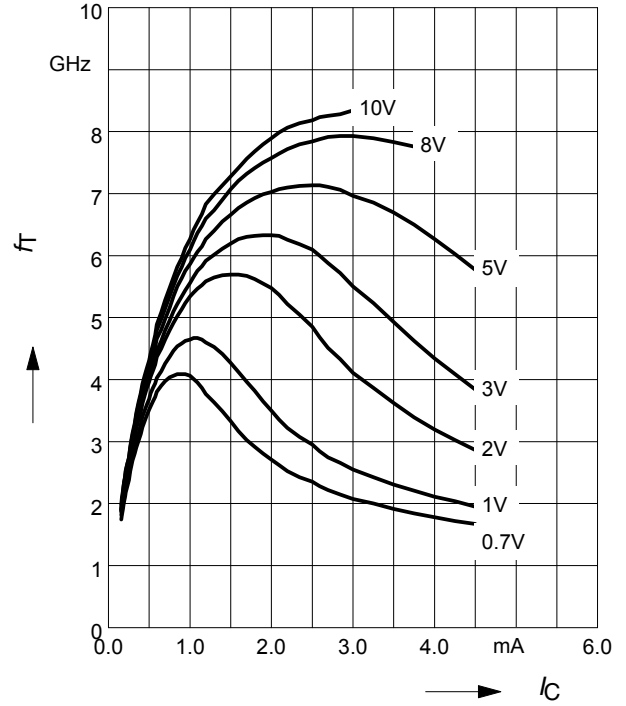

Power Gain $G_{ma}, G_{ms} = f(I_C)$

$f = 0.9\text{GHz}$

$V_{CE} = \text{Parameter}$

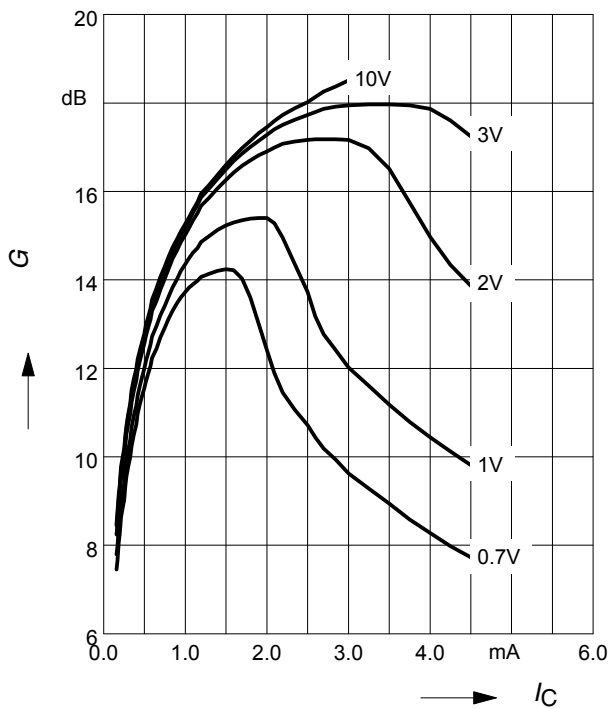

Power Gain $G_{ma}, G_{ms} = f(I_C)$

$f = 1.8\text{GHz}$

$V_{CE} = \text{Parameter}$

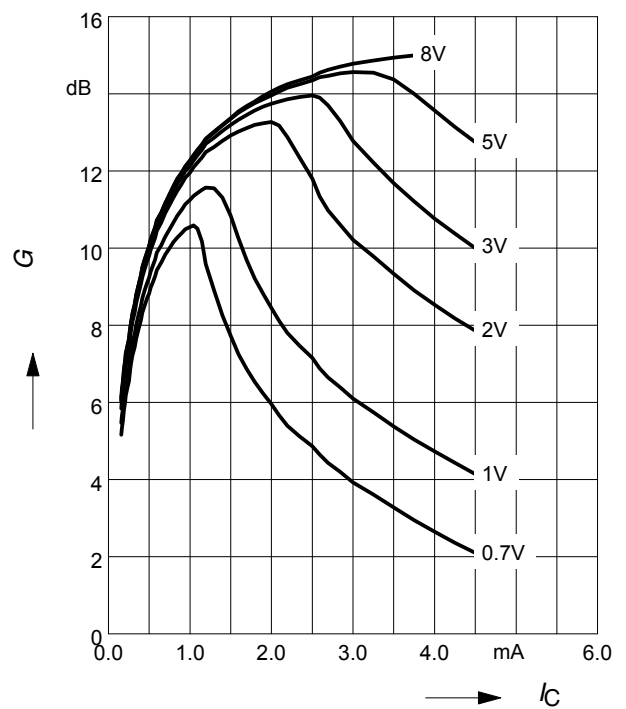

Power Gain $G_{ma}, G_{ms} = f(V_{CE})$:

$|S_{21}|^2 = f(V_{CE})$:

$f =$ Parameter

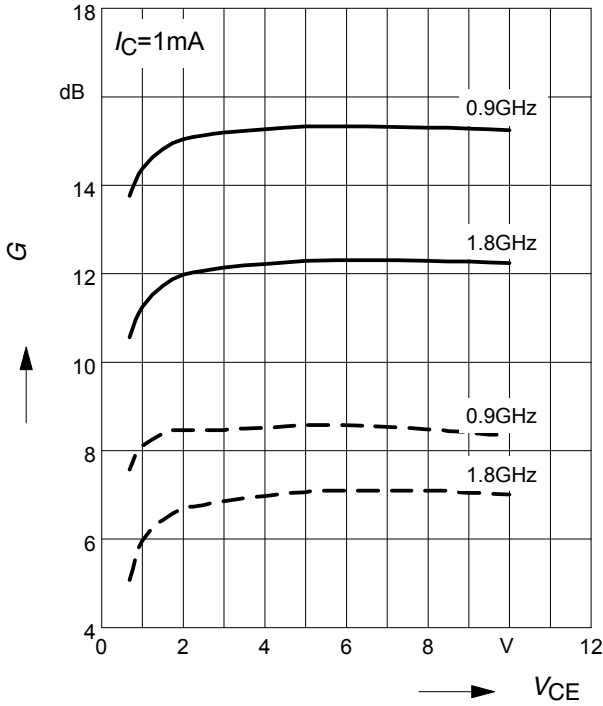

Intermodulation Intercept Point $IP_3 = f(I_C)$

(3rd order, Output, $Z_S = Z_L = 50\Omega$)

$V_{CE} =$ Parameter, $f = 900\text{MHz}$

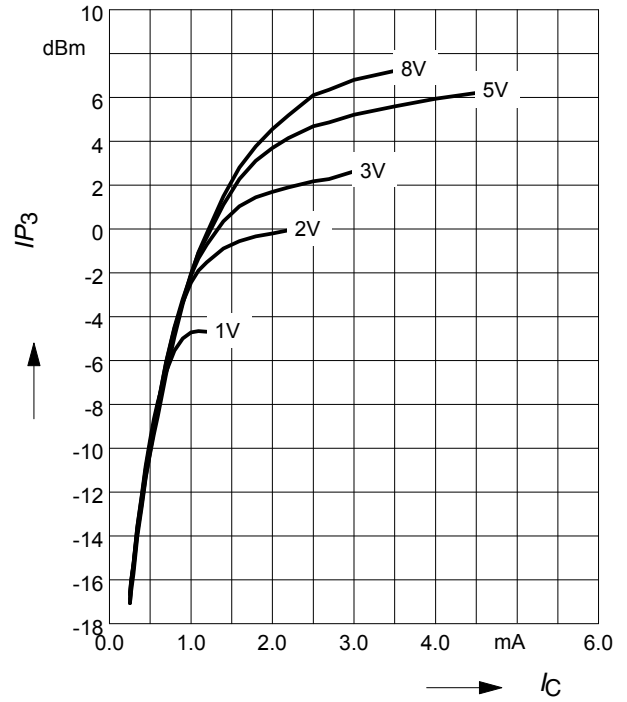

Power Gain $G_{ma}, G_{ms} = f(f)$

$V_{CE} =$ Parameter

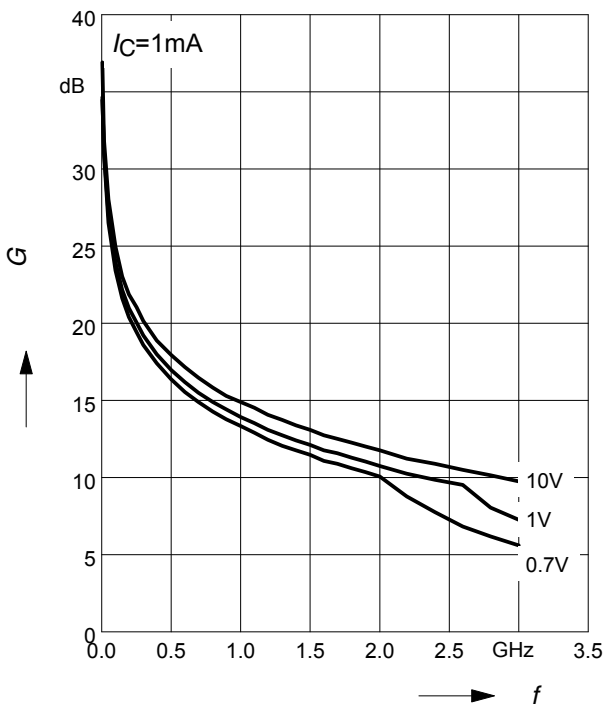

Power Gain $|S_{21}|^2 = f(f)$

$V_{CE} =$ Parameter

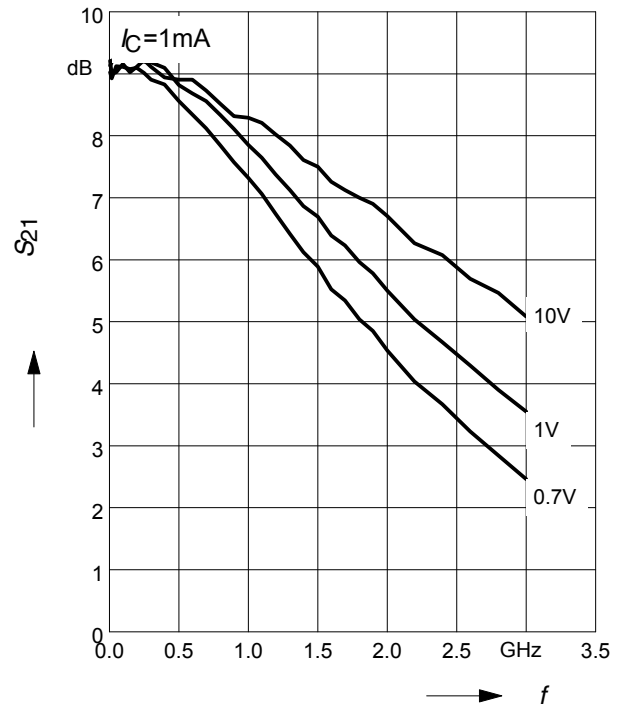



LittleDiode supplies new, hard to find or obsolete electronic components and semiconductors all over the world.

With over two million different components listed you are sure to find the part you need.

Feel free to visit us today at our online store:

LittleDiode.com

Looking forward to providing you with the best possible service.