

DATA SHEET

BFQ270

NPN 6 GHz wideband transistor

Product specification
File under Discrete Semiconductors, SC14

September 1995

NPN 6 GHz wideband transistor

BFQ270

FEATURES

- High power gain
- Emitter-ballasting resistors for good thermal stability
- Gold metallization ensures excellent reliability.

PINNING

PIN	DESCRIPTION
1	collector
2	emitter
3	base
4	emitter

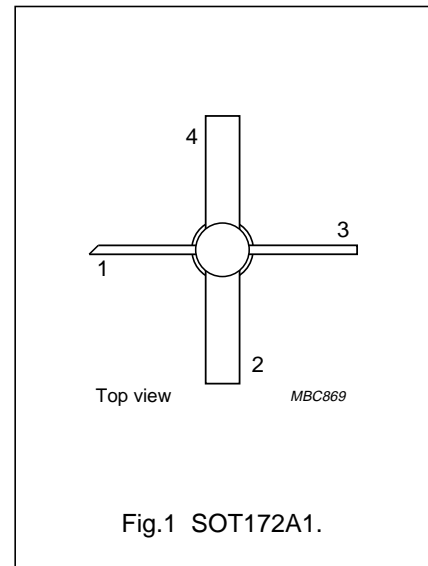

Fig.1 SOT172A1.

DESCRIPTION

Silicon NPN transistor mounted in a 4-lead dual-emitter SOT172A1 envelope with a ceramic cap. All leads are isolated from the mounting base.

It is primarily intended for use in MATV and CATV amplifiers.

QUICK REFERENCE DATA

SYMBOL	PARAMETER	CONDITIONS	MIN.	TYP.	MAX.	UNIT
V_{CB0}	collector-base voltage	open emitter	–	–	25	V
V_{CEO}	collector-emitter voltage	open base	–	–	19	V
I_C	DC collector current		–	–	500	mA
P_{tot}	total power dissipation	up to $T_c = 100\text{ }^\circ\text{C}$	–	–	10	W
h_{FE}	DC current gain	$I_C = 240\text{ mA}; V_{CE} = 18\text{ V}; T_j = 25\text{ }^\circ\text{C}$	60	–	–	
f_T	transition frequency	$I_C = 240\text{ mA}; V_{CE} = 18\text{ V}; f = 1\text{ GHz}; T_{amb} = 25\text{ }^\circ\text{C}$	–	6	–	GHz
G_{UM}	maximum unilateral power gain	$I_C = 240\text{ mA}; V_{CE} = 18\text{ V}; f = 800\text{ MHz}; T_{amb} = 25\text{ }^\circ\text{C}$	–	10	–	dB
V_O	output voltage	$d_{im} = -60\text{ dB}; I_C = 240\text{ mA}; V_{CE} = 18\text{ V}; R_L = 75\text{ }\Omega; f_{(p+q-t)} = 793.25\text{ MHz}$	–	1.6	–	V

WARNING

Product and environmental safety - toxic materials

This product contains beryllium oxide. The product is entirely safe provided that the BeO discs are not damaged. All persons who handle, use or dispose of this product should be aware of its nature and of the necessary safety precautions. After use, dispose of as chemical or special waste according to the regulations applying at the location of the user. It must never be thrown out with the general or domestic waste.

NPN 6 GHz wideband transistor

BFQ270

LIMITING VALUES

In accordance with the Absolute Maximum System (IEC 134).

SYMBOL	PARAMETER	CONDITIONS	MIN.	MAX.	UNIT
V _{CBO}	collector-base voltage	open emitter	–	25	V
V _{CEO}	collector-emitter voltage	open base	–	19	V
V _{EBO}	emitter-base voltage	open collector	–	2	V
I _C	DC collector current		–	500	mA
P _{tot}	total power dissipation	up to T _C = 100 °C	–	10	W
T _{stg}	storage temperature		–65	150	°C
T _j	junction temperature		–	200	°C

THERMAL RESISTANCE

SYMBOL	PARAMETER	THERMAL RESISTANCE
R _{th j-c}	thermal resistance from junction to case	10 K/W

CHARACTERISTICS

T_j = 25 °C unless otherwise specified.

SYMBOL	PARAMETER	CONDITIONS	MIN.	TYP.	MAX.	UNIT
I _{CBO}	collector cut-off current	I _E = 0; V _{CB} = 18 V	–	–	100	μA
h _{FE}	DC current gain	I _C = 240 mA; V _{CE} = 18 V	60	110	–	
C _c	collector capacitance	I _E = i _e = 0; V _{CB} = 18 V; f = 1 MHz	–	3.6	–	pF
C _e	emitter capacitance	I _C = i _c = 0; V _{EB} = 0.5 V; f = 1 MHz	–	11	–	pF
C _{re}	feedback capacitance	I _C = 0; V _{CB} = 18 V; f = 1 MHz	2	2.6	–	pF
C _{cs}	collector-stud capacitance		–	1.2	–	pF
f _T	transition frequency	I _C = 240 mA; V _{CE} = 18 V; f = 1 GHz; T _{amb} = 25 °C	4.5	6	–	GHz
G _{UM}	maximum unilateral power gain (note 1)	I _C = 240 mA; V _{CE} = 18 V; f = 500 MHz; T _{amb} = 25 °C	–	16	–	dB
		I _C = 240 mA; V _{CE} = 18 V; f = 1 GHz; T _{amb} = 25 °C	–	10	–	dB
V _O	output voltage	note 2	–	1.6	–	V
d ₂	second order intermodulation distortion	note 3	–	–50	–	dB

Notes

- G_{UM} is the maximum unilateral power gain, assuming S₁₂ is zero and $G_{UM} = 10 \log \left(\frac{|S_{21}|^2}{(1 - |S_{11}|^2)(1 - |S_{22}|^2)} \right)$ dB
- d_{im} = –60 dB (DIN 45004); I_C = 240 mA; V_{CE} = 18 V; R_L = 75 Ω;
V_p = V_O; f_p = 795.25 MHz;
V_q = V_O – 6 dB; f_q = 803.25 MHz;
V_r = V_O – 6 dB; f_r = 805.25 MHz;
measured at f_(p+q-r) = 793.25 MHz.
- I_C = 240 mA; V_{CE} = 18 V; R_L = 75 Ω;
V_p = V_q = V_O = 50.5 dBmV = 335 mV;
f_(p+q) = 810 MHz; f_p = 250 MHz; f_q = 560 MHz.

NPN 6 GHz wideband transistor

BFQ270

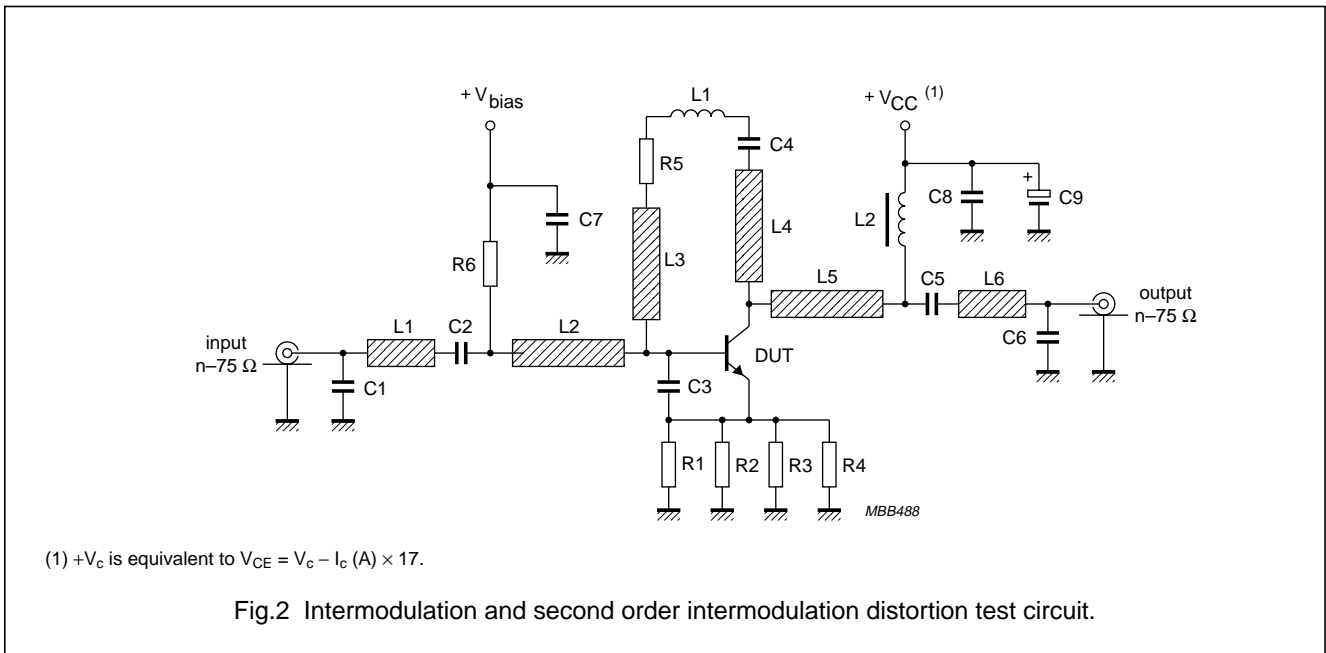

List of components (see test circuit)

DESIGNATION	DESCRIPTION	VALUE	DIMENSIONS	CATALOGUE NO.
C1	miniature ceramic plate capacitor	0.82 pF		2222 680 03827
C2, C5, C7, C8	multilayer ceramic capacitor	10 nF		2222 852 47103
C3	multilayer ceramic chip capacitor	2.2 pF		2222 855 12228
C4 (note 1)	miniature ceramic plate capacitor	1 nF		2222 630 08102
C6	miniature ceramic plate capacitor	1.2 pF		2222 680 03128
C9	electrolytic capacitor	4.7 μF		2222 014 28478
L1 (note 1)	4.5 turns loosely wound 0.4 mm enamelled copper wire	≈35 nH	internal coil diameter 2 mm	
L2	Ferroxcube choke	5 μH		3122 108 20153
ML1, ML6	microstripline	75 Ω	width 2.46 mm; length 9 mm	
ML2, ML5	microstripline	75 Ω	width 2.46 mm; length 22 mm	
ML3, ML4	microstripline	145 Ω	width 0.5 mm; length 12 mm	
R1, R2, R3, R4	metal film resistor	68 Ω	type MR25	2322 151 76819
R5 (note 1)	metal film resistor	240 Ω	type SFR16T	2322 180 73241
R6	metal film resistor	10 kΩ	type SFR16T	2322 180 73103

Note

1. Components C4, L1, and R5 are mounted in a cavity in the brass ground plate.

The circuit is constructed on a printed circuit board and 10 mm thick brass ground plate, with a relative dielectric constant of (ε_r = 2.2), thickness 1.57 mm; thickness of copper 0.017 mm (E.G. Rogers' RT/Duroid 5880).

NPN 6 GHz wideband transistor

BFQ270

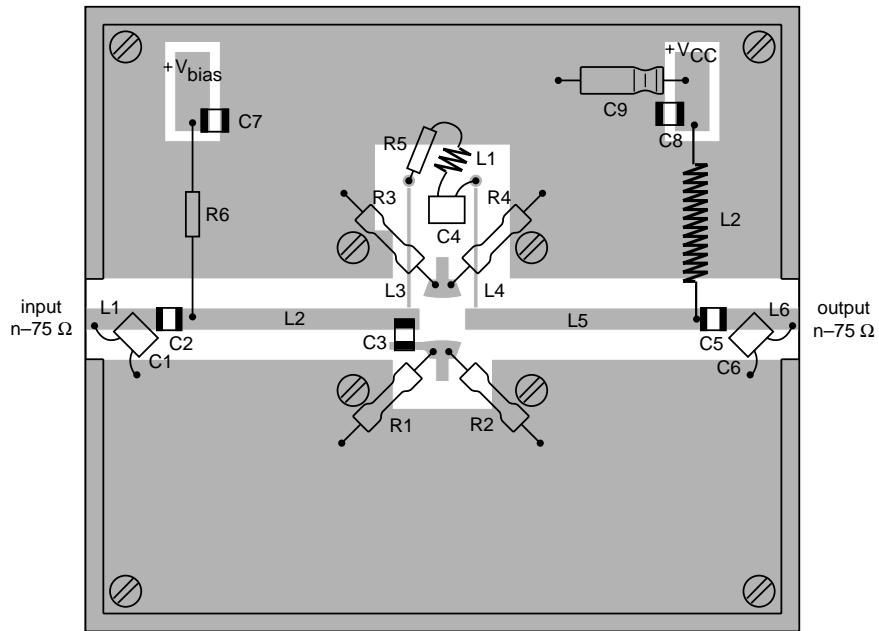

MBB487

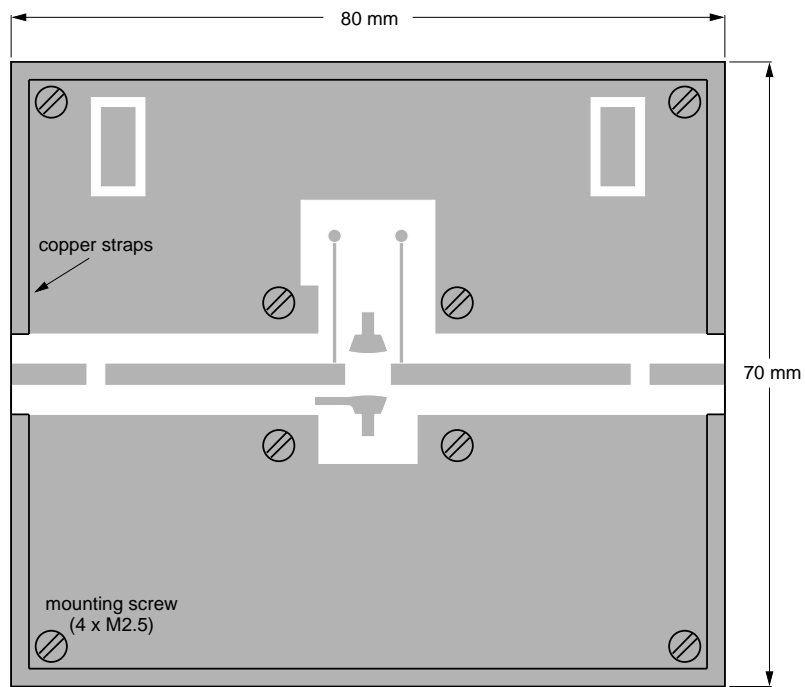

MBB486

Fig.3 Intermodulation test circuit printed circuit board.

NPN 6 GHz wideband transistor

BFQ270

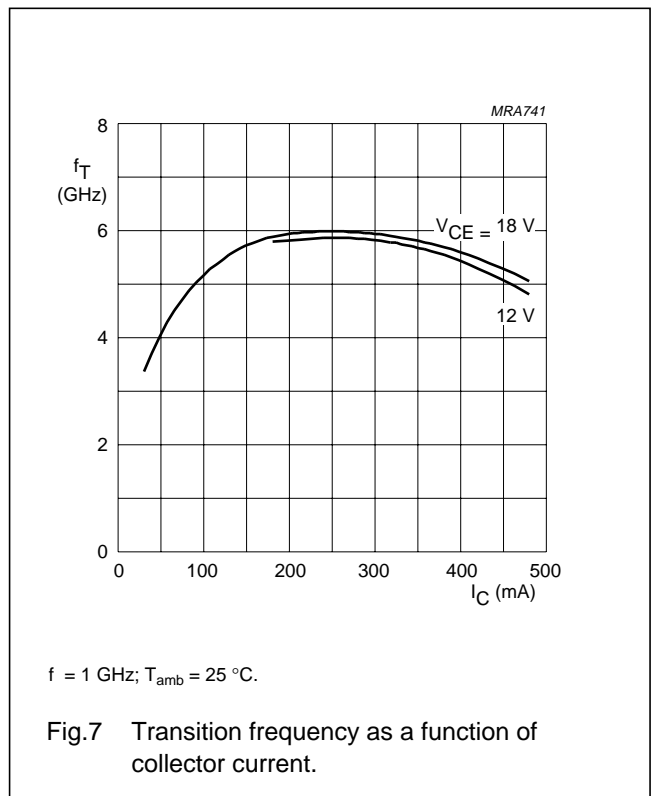
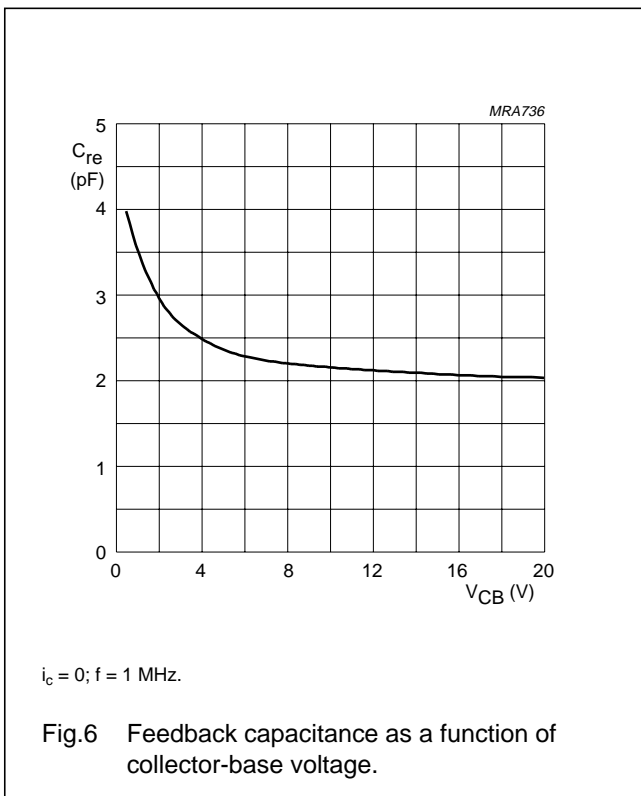
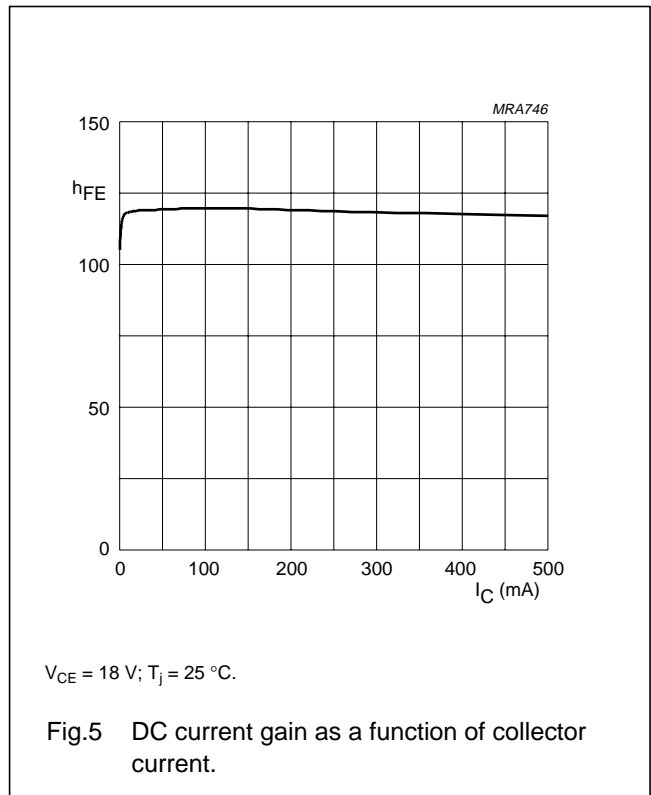
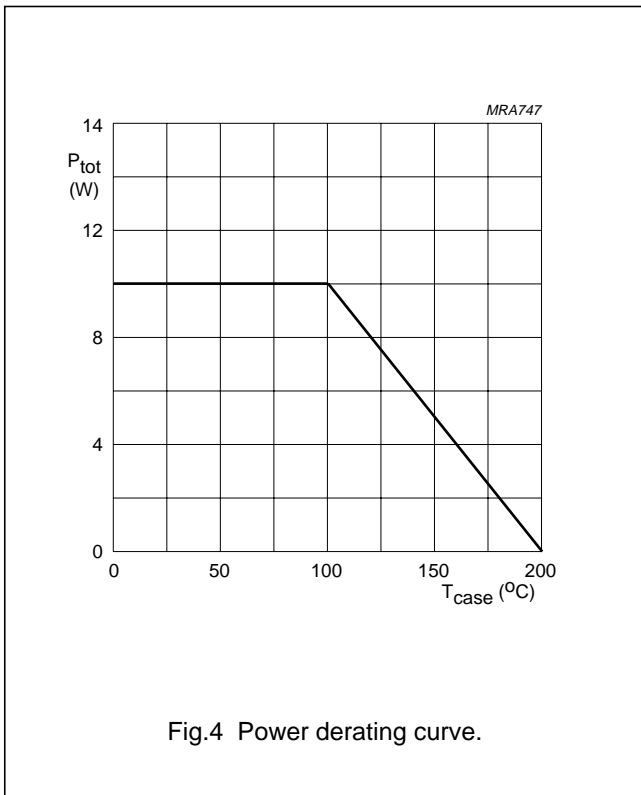

NPN 6 GHz wideband transistor

BFQ270

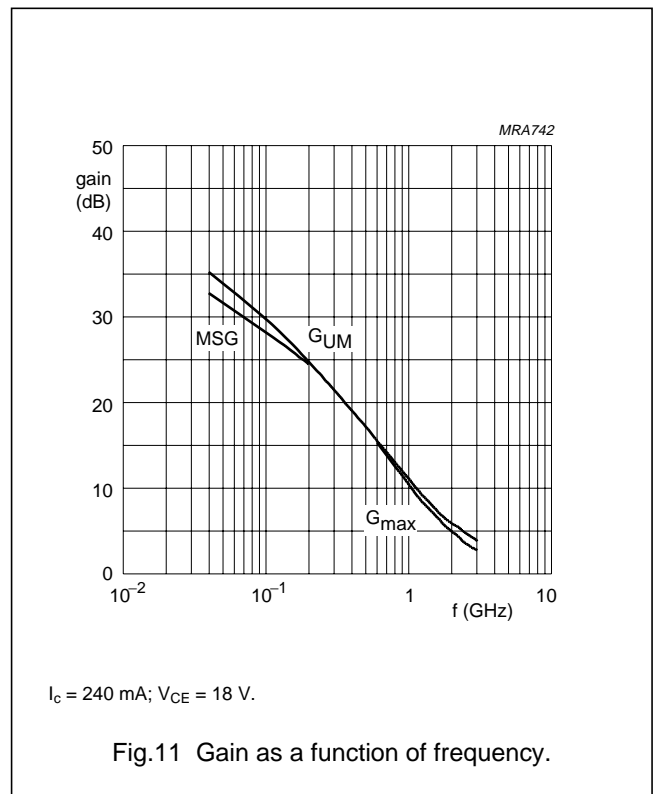
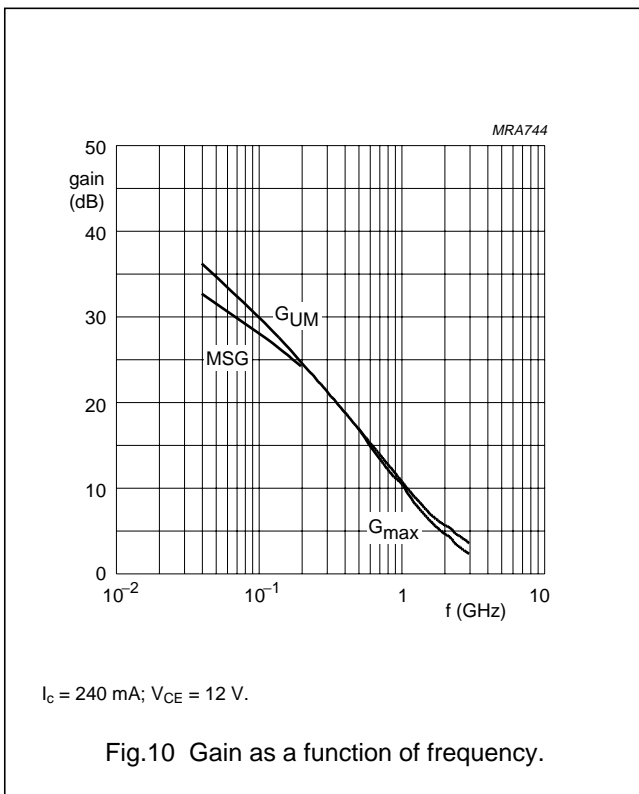
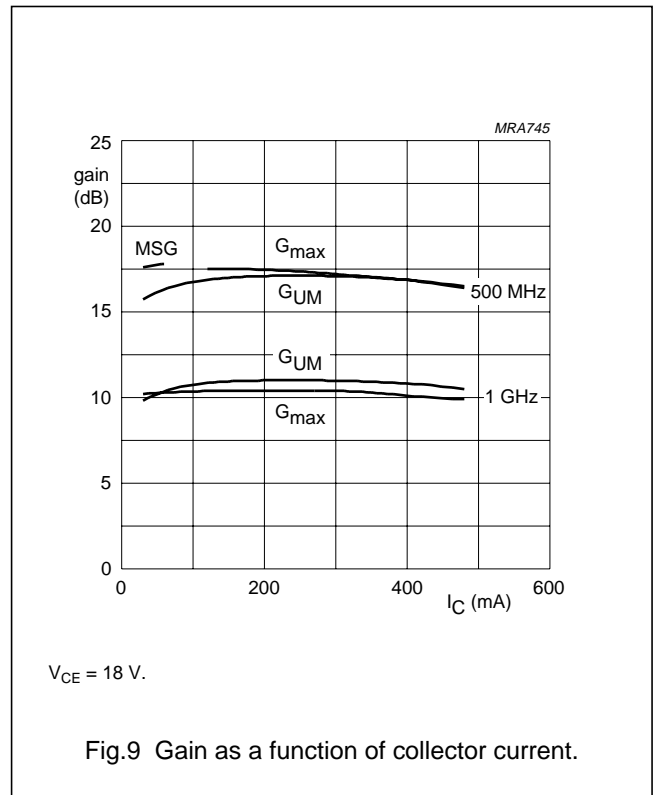
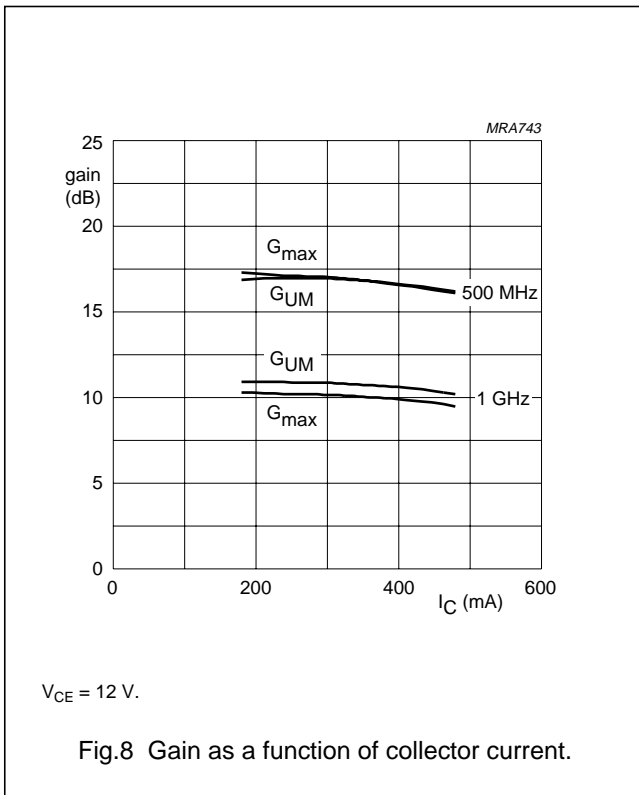

NPN 6 GHz wideband transistor

BFQ270

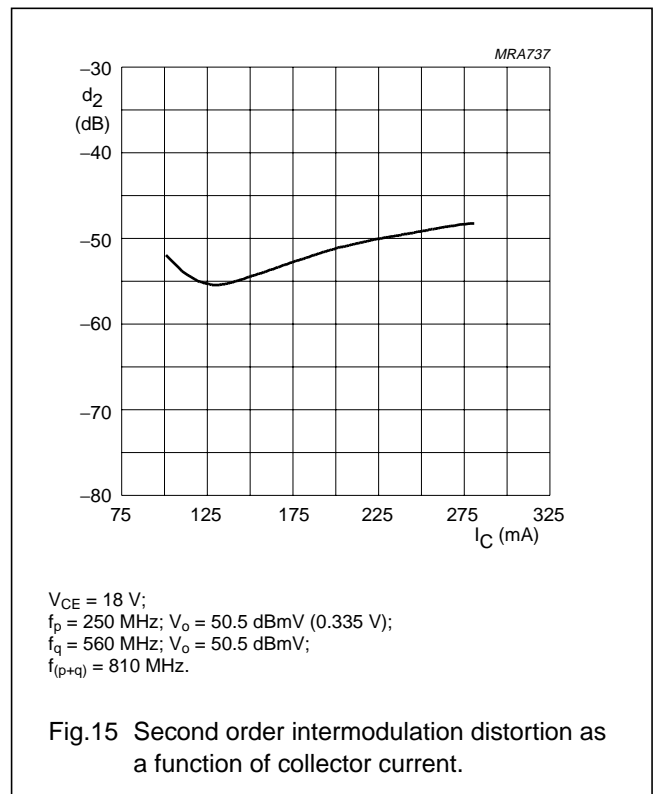
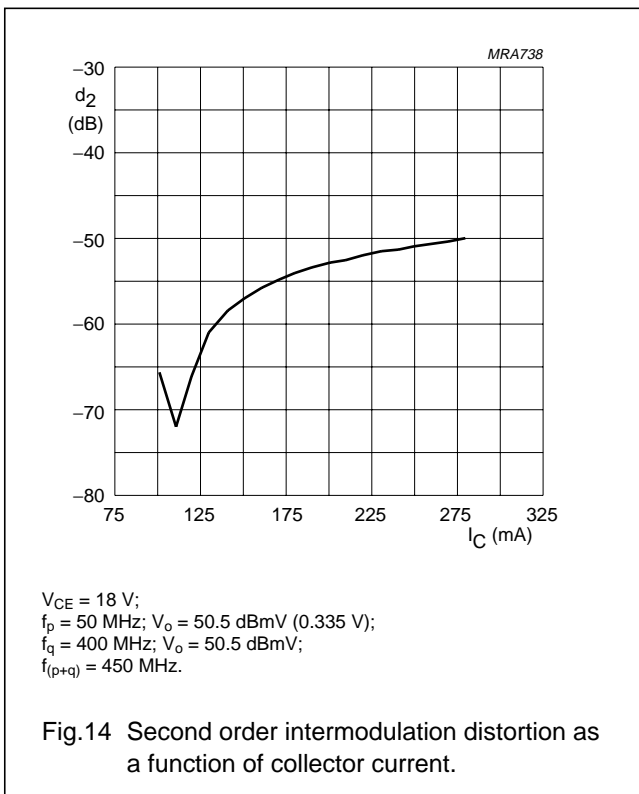
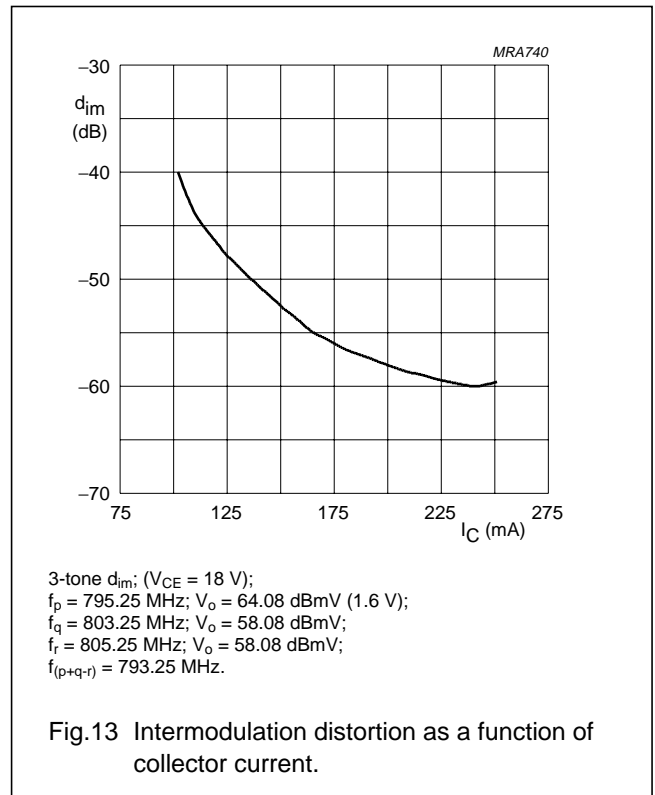
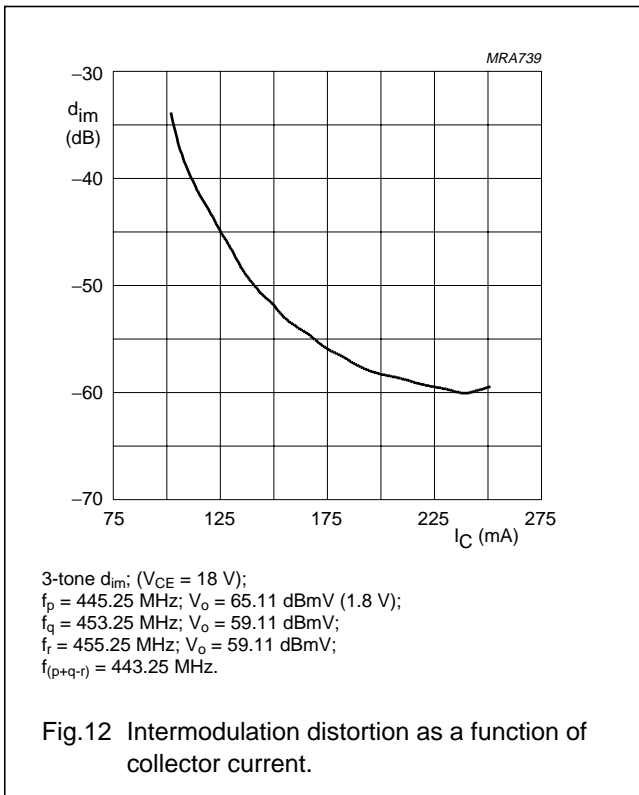

NPN 6 GHz wideband transistor

BFQ270

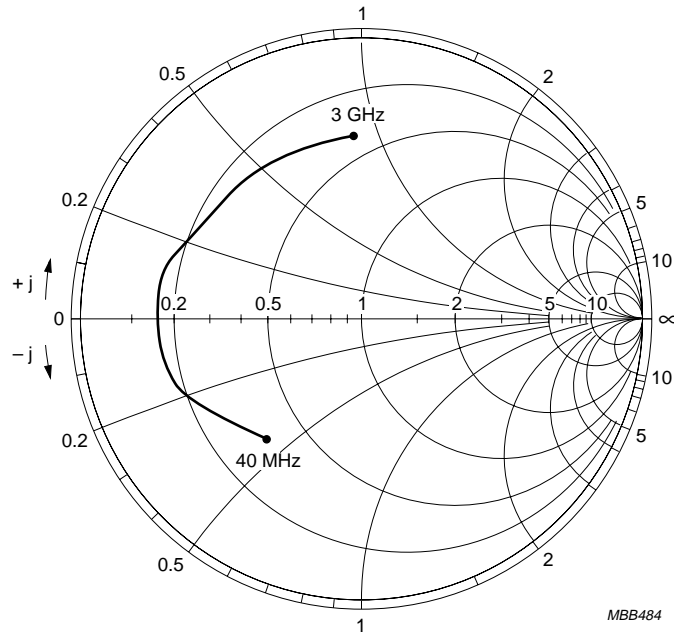

$I_c = 240 \text{ mA}$; $V_{CE} = 18 \text{ V}$.
 $Z_0 = 50 \Omega$.

Fig.16 Common emitter input reflection coefficient (S_{11}).

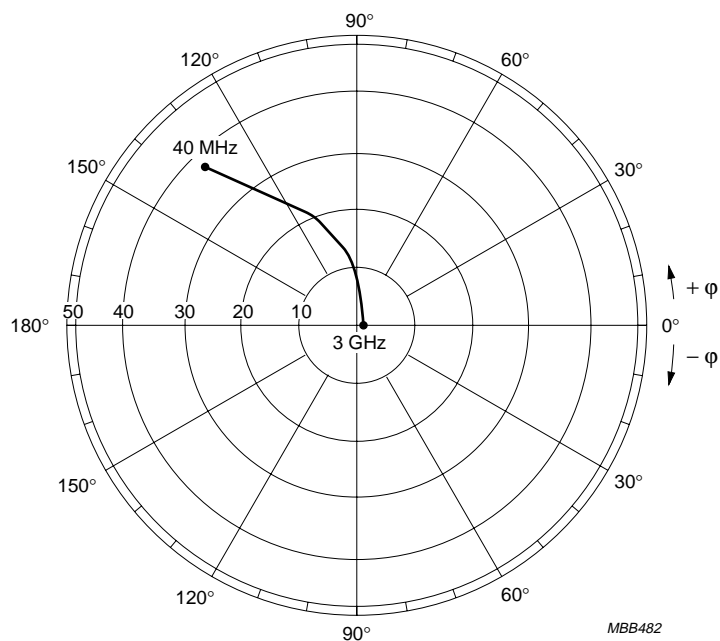

$I_c = 240 \text{ mA}$; $V_{CE} = 18 \text{ V}$.

Fig.17 Common emitter forward transmission coefficient (S_{21}).

NPN 6 GHz wideband transistor

BFQ270

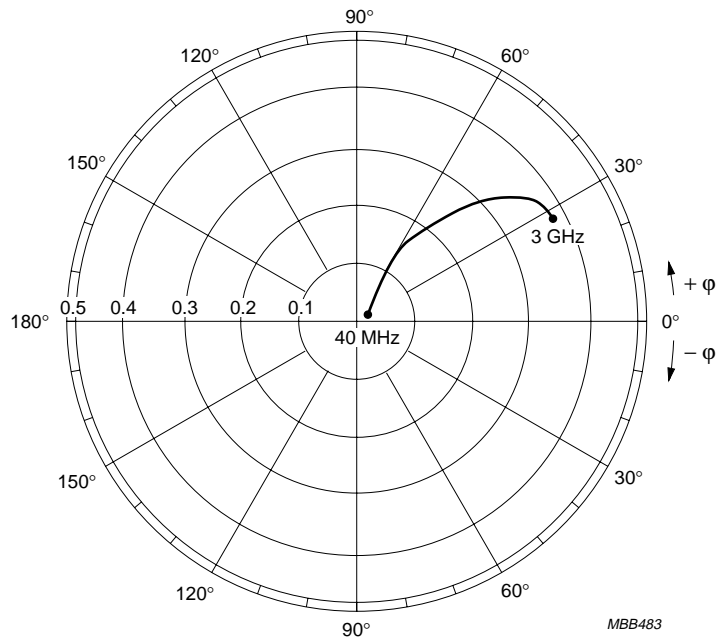

$I_c = 240 \text{ mA}; V_{CE} = 18 \text{ V}.$

Fig.18 Common emitter reverse transmission coefficient (S_{12}).

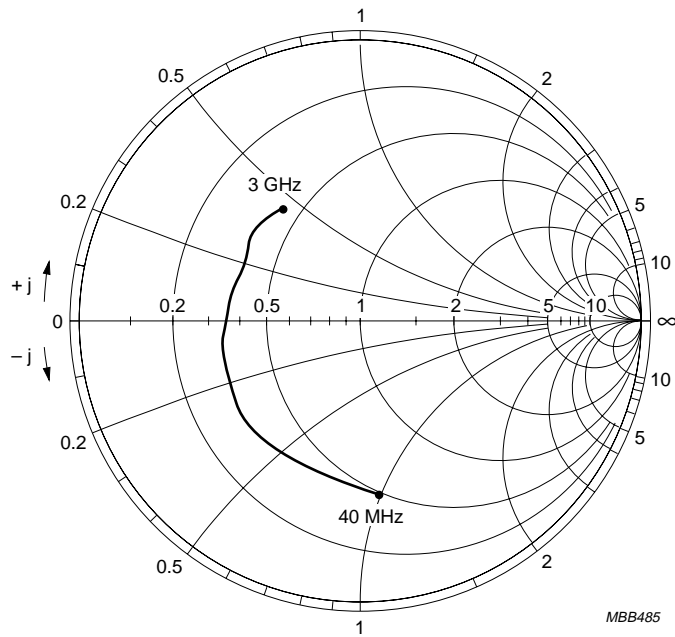

$I_c = 240 \text{ mA}; V_{CE} = 18 \text{ V}.$
 $Z_0 = 50 \Omega.$

Fig.19 Common emitter output reflection coefficient (S_{22}).

NPN 6 GHz wideband transistor

BFQ270

PACKAGE OUTLINE

Studded ceramic package; 4 leads

SOT172A1

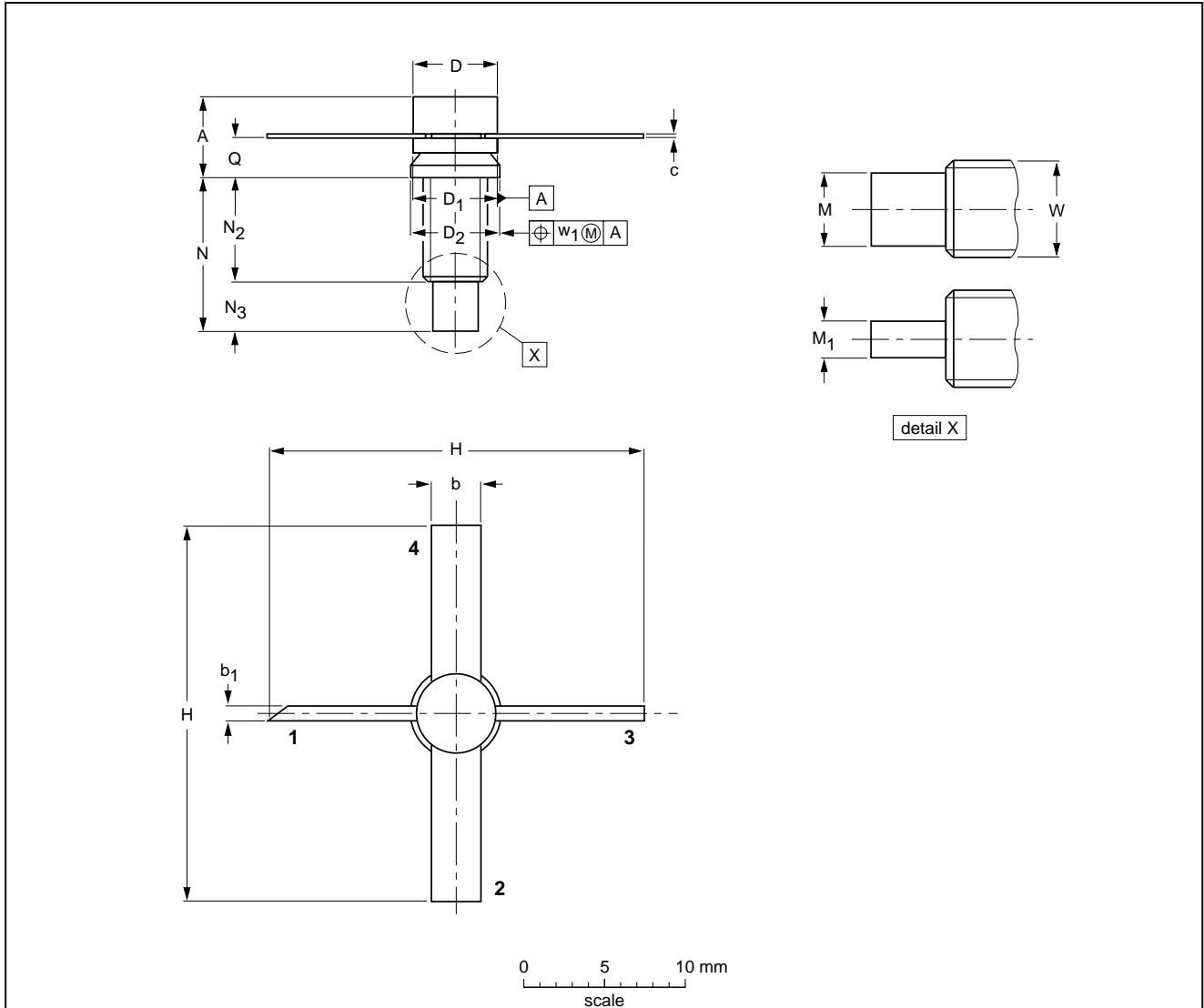

DIMENSIONS (millimetre dimensions are derived from the original inch dimensions)

UNIT	A	b	b ₁	c	D	D ₁	D ₂	H	M	M ₁	N	N ₂	N ₃	Q	W	w ₁
mm	5.31 4.34	3.31 3.04	0.89 0.63	0.16 0.10	5.20 4.95	5.33 5.08	5.33 5.08	26.17 24.63	3.05 2.79	1.66 1.39	11.82 10.89	8.89 6.90	3.69 2.92	2.90 2.31	8-32 UNC	0.38
inches	0.209 0.171	0.130 0.120	0.035 0.025	0.006 0.004	0.205 0.195	0.210 0.200	0.210 0.200	1.03 0.97	0.12 0.11	0.065 0.055	0.465 0.429	0.350 0.272	0.145 0.115	0.114 0.091		0.015

OUTLINE VERSION	REFERENCES				EUROPEAN PROJECTION	ISSUE DATE
	IEC	JEDEC	EIAJ			
SOT172A1						97-06-28

NPN 6 GHz wideband transistor

BFQ270

DEFINITIONS

Data Sheet Status	
Objective specification	This data sheet contains target or goal specifications for product development.
Preliminary specification	This data sheet contains preliminary data; supplementary data may be published later.
Product specification	This data sheet contains final product specifications.
Limiting values	
Limiting values given are in accordance with the Absolute Maximum Rating System (IEC 134). Stress above one or more of the limiting values may cause permanent damage to the device. These are stress ratings only and operation of the device at these or at any other conditions above those given in the Characteristics sections of the specification is not implied. Exposure to limiting values for extended periods may affect device reliability.	
Application information	
Where application information is given, it is advisory and does not form part of the specification.	

LIFE SUPPORT APPLICATIONS

These products are not designed for use in life support appliances, devices, or systems where malfunction of these products can reasonably be expected to result in personal injury. Philips customers using or selling these products for use in such applications do so at their own risk and agree to fully indemnify Philips for any damages resulting from such improper use or sale.



LittleDiode supplies new, hard to find or obsolete electronic components and semiconductors all over the world.

With over two million different components listed you are sure to find the part you need.

Feel free to visit us today at our online store:

LittleDiode.com

Looking forward to providing you with the best possible service.