

NPN Silicon RF Transistor

BFQ 70

- For low-noise IF and broadband amplifiers in antenna and telecommunications systems at collector currents from 2 mA to 20 mA.
- Hermetically sealed ceramic package
- HiRel/Mil screening available.

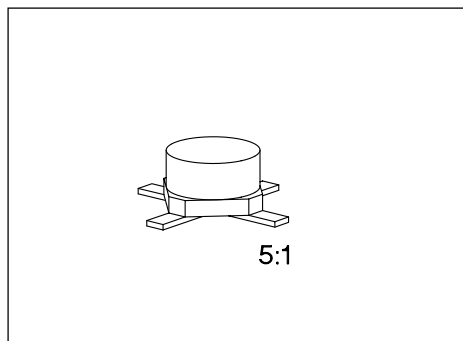

ESD: Electrostatic discharge sensitive device, observe handling precautions!

Type	Marking	Ordering Code (tape and reel)	Pin Configuration				Package ¹⁾
			1	2	3	4	
BFQ 70	70	Q62702-F774	B	E	C	E	Cerex-X

Maximum Ratings

Parameter	Symbol	Values	Unit
Collector-emitter voltage	V_{CE0}	15	V
Collector-emitter voltage, $V_{BE} = 0$	V_{CES}	20	
Collector-base voltage	V_{CB0}	20	
Emitter-base voltage	V_{EB0}	2.5	
Collector current	I_C	35	mA
Base current	I_B	4	
Total power dissipation, $T_s \leq 121 \text{ }^\circ\text{C}^3)$	P_{tot}	300	mW
Junction temperature	T_j	175	
Ambient temperature range	T_A	- 65 ... + 175	
Storage temperature range	T_{stg}	- 65 ... + 175	

Thermal Resistance

Junction - ambient ²⁾	$R_{th JA}$	≤ 260	K/W
Junction - soldering point ³⁾	$R_{th JS}$	≤ 180	

1) For detailed dimensions see chapter Package Outlines.

2) Package mounted on alumina 16 mm × 25 mm × 0.7 mm.

3) T_s is measured on the collector lead at the soldering point to the pcb.

Electrical Characteristics

at $T_A = 25\text{ °C}$, unless otherwise specified.

Parameter	Symbol	Values			Unit
		min.	typ.	max.	

DC Characteristics

Collector-emitter breakdown voltage $I_C = 1\text{ mA}$, $I_B = 0$	$V_{(BR)CE0}$	15	–	–	V
Collector-base cutoff current $V_{CB} = 10\text{ V}$, $I_E = 0$	I_{CB0}	–	–	50	nA
Emitter-base cutoff current $V_{EB} = 2\text{ V}$, $I_C = 0$	I_{EB0}	–	–	10	μA
DC current gain $I_C = 3\text{ mA}$, $V_{CE} = 6\text{ V}$ $I_C = 10\text{ mA}$, $V_{CE} = 6\text{ V}$	h_{FE}	50 50	– 130	250 –	–
Collector-emitter saturation voltage $I_C = 20\text{ mA}$, $I_B = 1\text{ mA}$	V_{CEsat}	–	0.1	0.4	V
Base-emitter voltage $I_C = 10\text{ mA}$, $V_{CE} = 6\text{ V}$	V_{BE}	–	0.78	–	

Electrical Characteristics

at $T_A = 25\text{ °C}$, unless otherwise specified.

Parameter	Symbol	Values			Unit
		min.	typ.	max.	

AC Characteristics

Transition frequency $I_C = 3\text{ mA}$, $V_{CE} = 6\text{ V}$, $f = 200\text{ MHz}$ $I_C = 20\text{ mA}$, $V_{CE} = 6\text{ V}$, $f = 200\text{ MHz}$	f_t	– 3.6	2.7 5	– –	GHz
Collector-base capacitance $V_{CB} = 6\text{ V}$, $V_{BE} = v_{be} = 0$, $f = 1\text{ MHz}$	C_{cb}	–	0.46	0.6	pF
Collector-emitter capacitance $V_{CE} = 6\text{ V}$, $V_{BE} = v_{be} = 0$, $f = 1\text{ MHz}$	C_{ce}	–	0.41	–	
Input capacitance $V_{EB} = 0.5\text{ V}$, $I_C = i_c = 0$, $f = 1\text{ MHz}$	C_{ibo}	–	2.2	–	
Output capacitance $V_{CE} = 6\text{ V}$, $V_{BE} = v_{be} = 0$, $f = 1\text{ MHz}$	C_{obs}	–	0.87	1.3	
Noise figure $I_C = 3\text{ mA}$, $V_{CE} = 6\text{ V}$, $f = 10\text{ MHz}$, $Z_S = 75\text{ }\Omega$ $I_C = 4\text{ mA}$, $V_{CE} = 6\text{ V}$, $f = 800\text{ MHz}$, $Z_S = 50\text{ }\Omega$	F	– –	0.9 1.5	1.2 –	dB
Power gain $I_C = 20\text{ mA}$, $V_{CE} = 6\text{ V}$, $f = 800\text{ MHz}$, $Z_S = Z_{Sopt}$, $Z_L = Z_{Lopt}$	G_{pe}	–	18	–	
Transducer gain $I_C = 10\text{ mA}$, $V_{CE} = 6\text{ V}$, $f = 1\text{ GHz}$, $Z_0 = 50\text{ }\Omega$	$ S_{21e} ^2$	–	13	–	
Linear output voltage two-tone intermodulation test $I_C = 20\text{ mA}$, $V_{CE} = 6\text{ V}$, $d_{IM} = 60\text{ dB}$, $f_1 = 806\text{ MHz}$, $f_2 = 810\text{ MHz}$, $Z_S = Z_L = 50\text{ }\Omega$	$V_{o1} = V_{o2}$	–	170	–	mV
Third order intercept point $I_C = 20\text{ mA}$, $V_{CE} = 6\text{ V}$, $f = 800\text{ MHz}$	IP_3	–	27.5	–	dBm

Total power dissipation $P_{tot} = f(T_A^*; T_S)$

*Package mounted on alumina

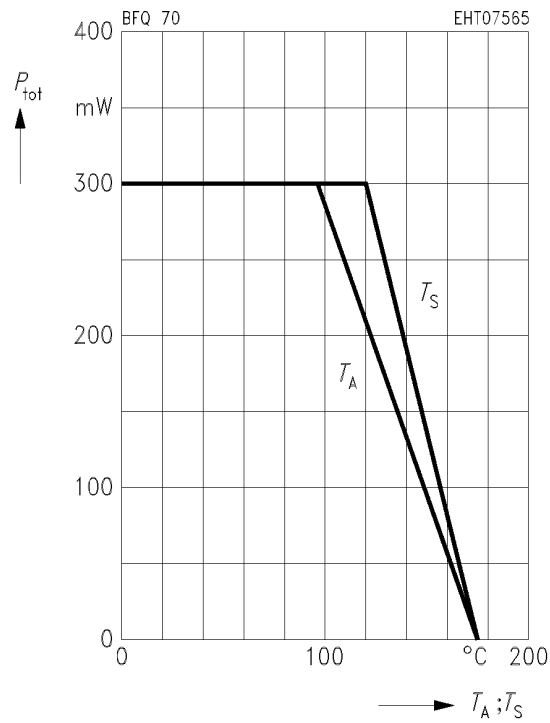

Transition frequency $f_T = f(I_C)$

$V_{CE} = 6\text{ V}, f = 200\text{ MHz}$

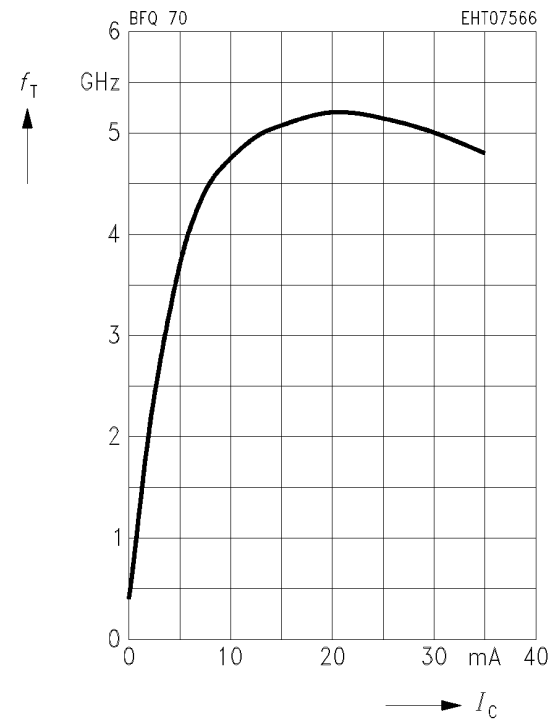

Collector-base capacitance $C_{cb} = f(V_{CB})$

$V_{BE} = v_{be} = 0, f = 1\text{ MHz}$

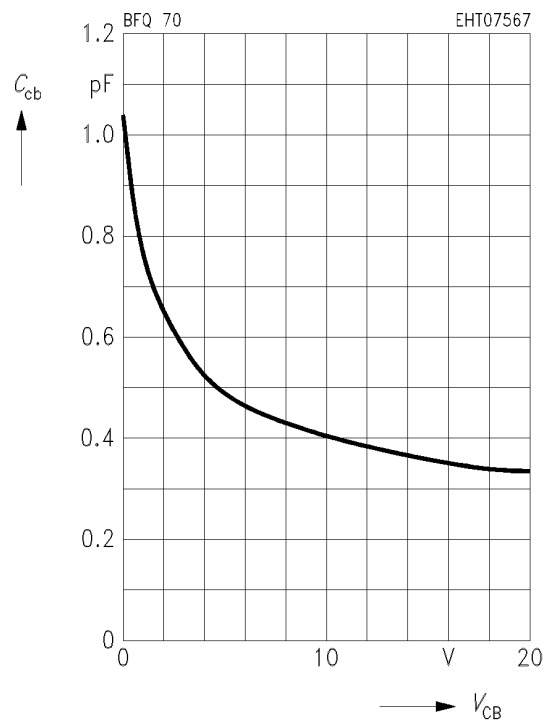

Common Emitter Noise Parameters

f	F_{min}	$G_p(F_{min})$	Γ_{opt}		R_N	N	$F_{50\Omega}$	$G_p(F_{50\Omega})$
GHz	dB	dB	MAG	ANG	Ω	—	dB	dB

$I_C = 3 \text{ mA}, V_{CE} = 6 \text{ V}, Z_0 = 50 \Omega$

0.01	0.8	—	(Z _s = 150 Ω)		—	—	1.2	—
------	-----	---	----------------------------------	--	---	---	-----	---

$I_C = 5 \text{ mA}, V_{CE} = 6 \text{ V}, Z_0 = 50 \Omega$

0.01	0.85	—	(Z _s = 100 Ω)		—	—	1.1	—
0.8	1.3	15.5	0.28	79	12	0.19	1.5	14.8

Noise figure $F = f(Z_s)$

$V_{CE} = 6 \text{ V}, f = 10 \text{ MHz}$

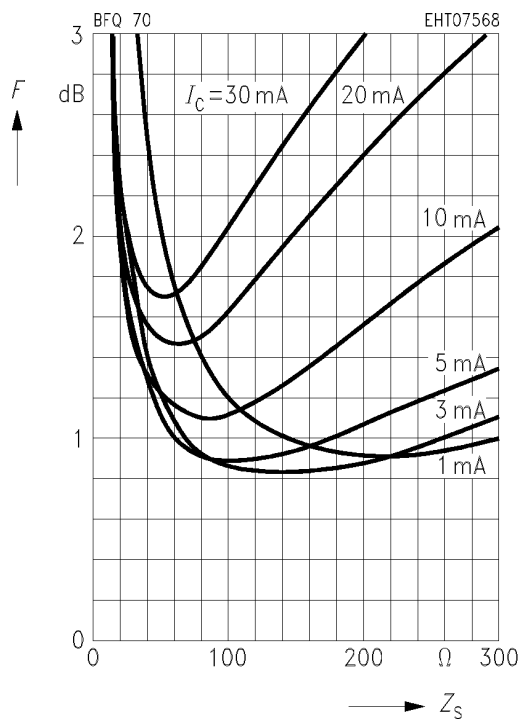

Circles of constant noise figure $F = f(Z_S)$
 in Z_S -plane, $I_C = 5 \text{ mA}$, $V_{CE} = 6 \text{ V}$, $f = 800 \text{ MHz}$

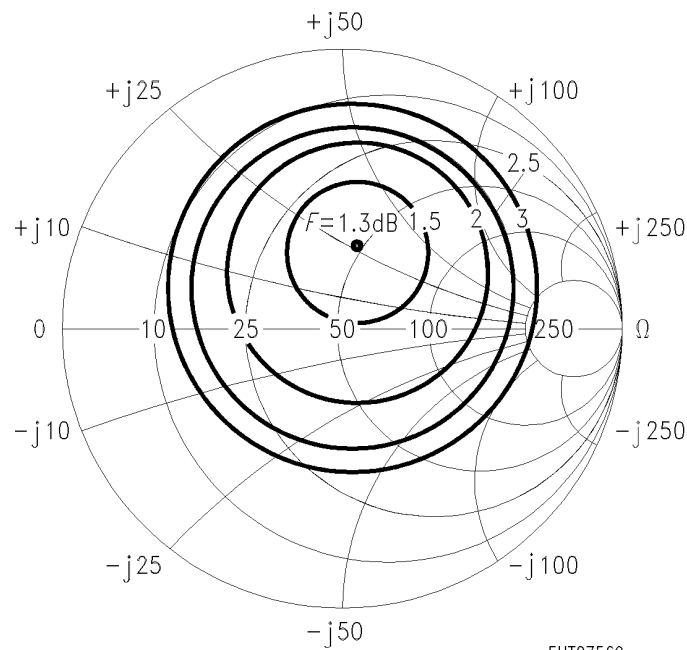

Noise figure $F = f(I_C)$
Power gain $G = f(I_C)$
 $V_{CE} = 6 \text{ V}$, $f = 800 \text{ MHz}$, $Z_{Lopt}(G)$

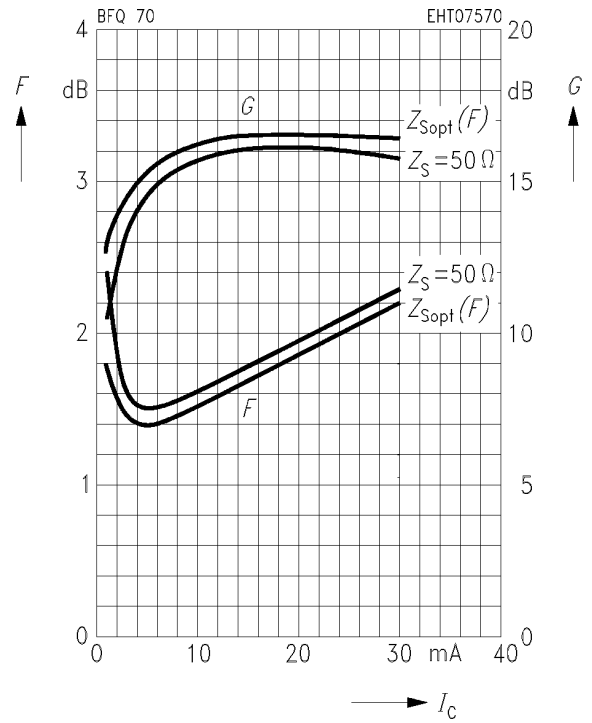

Common Emitter Power Gain

Power gain $G_{ms}, |S_{21e}|^2 = f(I_C)$

$V_{CE} = 6 \text{ V}, f = 200 \text{ MHz}, Z_0 = 50 \Omega$

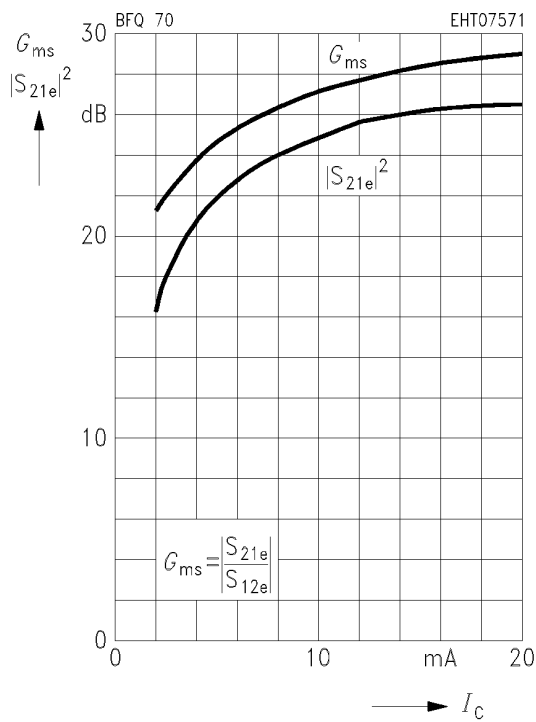

Power gain $G_{ms}, |S_{21e}|^2 = f(I_C)$

$V_{CE} = 6 \text{ V}, f = 500 \text{ MHz}, Z_0 = 50 \Omega$

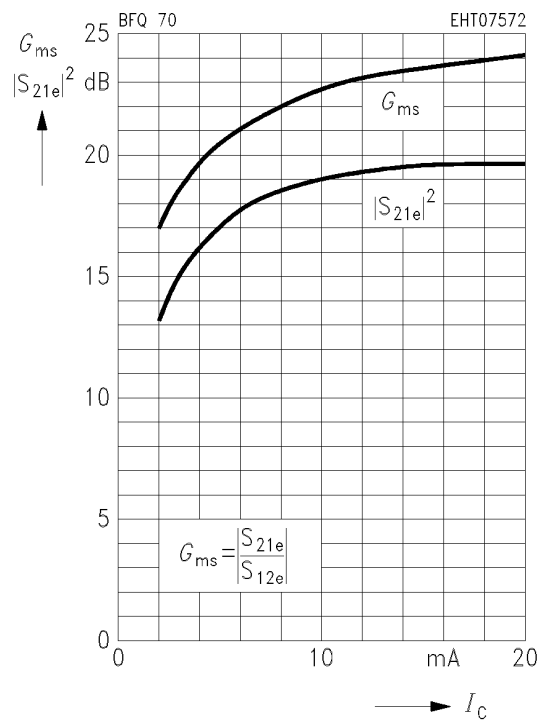

Power gain $G_{ms}, |S_{21e}|^2 = f(I_C)$

$V_{CE} = 6 \text{ V}, f = 800 \text{ MHz}, Z_0 = 50 \Omega$

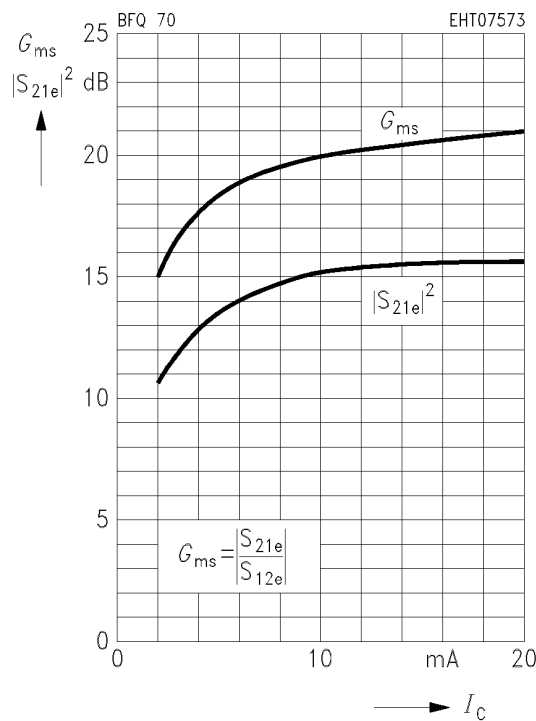

Power gain $G_{ma}, |S_{21e}|^2 = f(I_C)$

$V_{CE} = 6 \text{ V}, f = 1.5 \text{ GHz}, Z_0 = 50 \Omega$

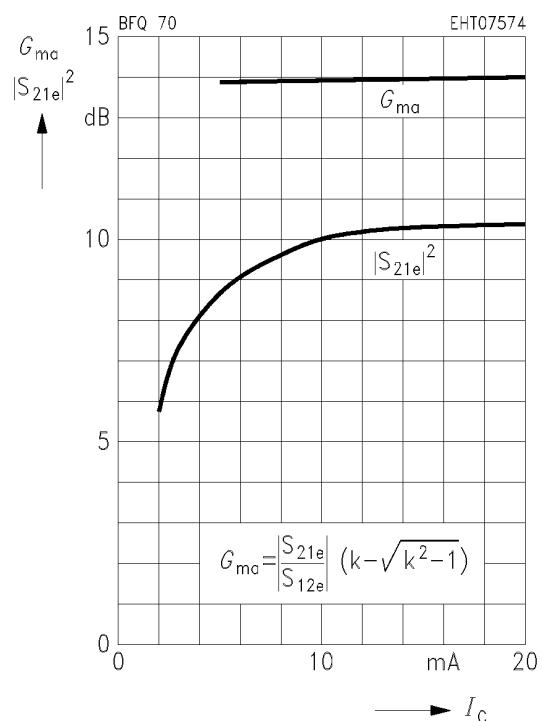

Power gain $G_{ms}, |S_{21e}|^2 = f(f)$

$I_C = 2 \text{ mA}, V_{CE} = 6 \text{ V}, Z_0 = 50 \Omega$

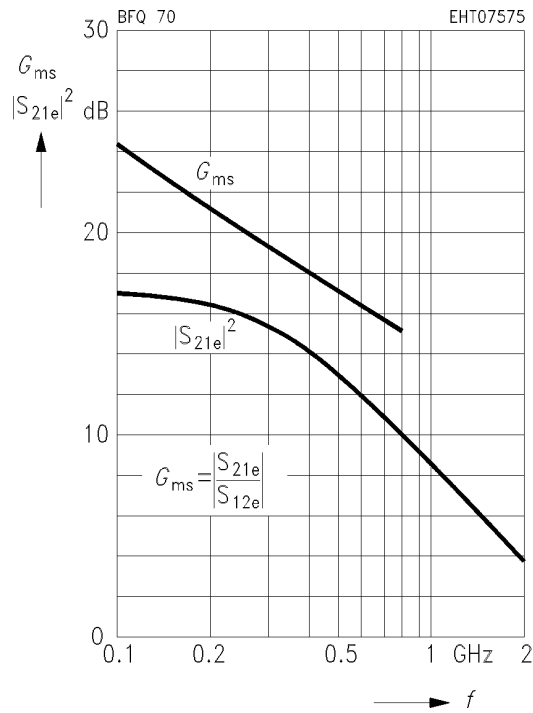

Power gain $G_{ma}, G_{ms}, |S_{21e}|^2 = f(f)$

$I_C = 5 \text{ mA}, V_{CE} = 6 \text{ V}, Z_0 = 50 \Omega$

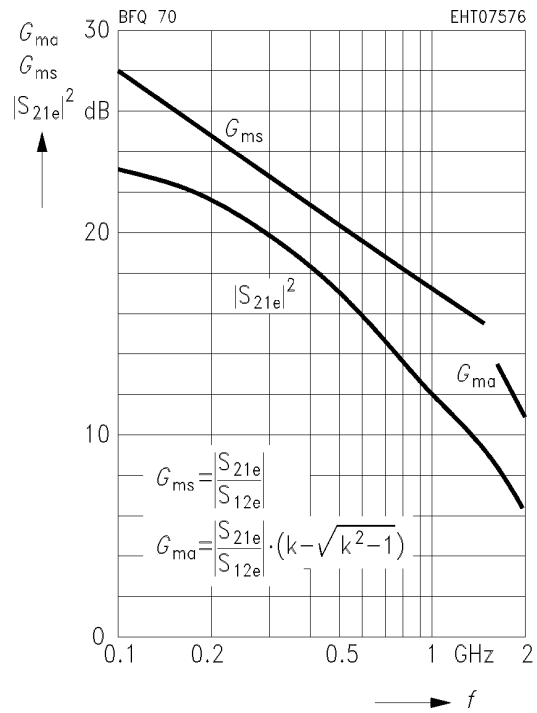

Power gain $G_{ma}, G_{ms}, |S_{21e}|^2 = f(f)$

$I_C = 10 \text{ mA}, V_{CE} = 6 \text{ V}, Z_0 = 50 \Omega$

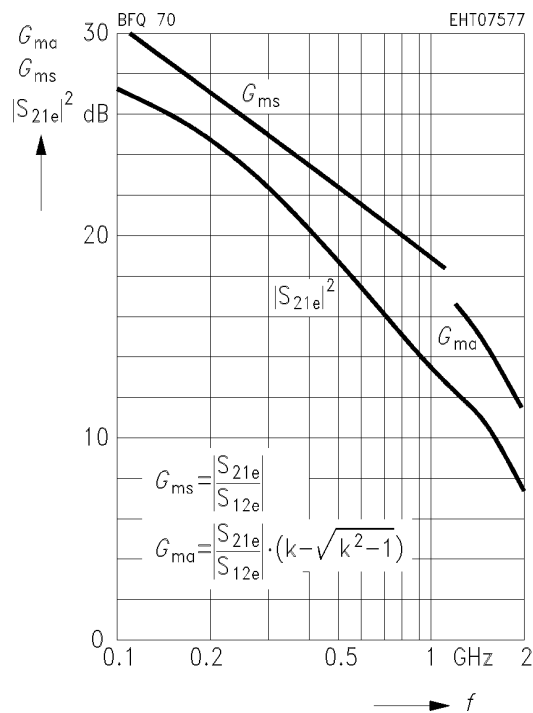

Power gain $G_{ma}, G_{ms}, |S_{21e}|^2 = f(f)$

$I_C = 20 \text{ mA}, V_{CE} = 6 \text{ V}, Z_0 = 50 \Omega$

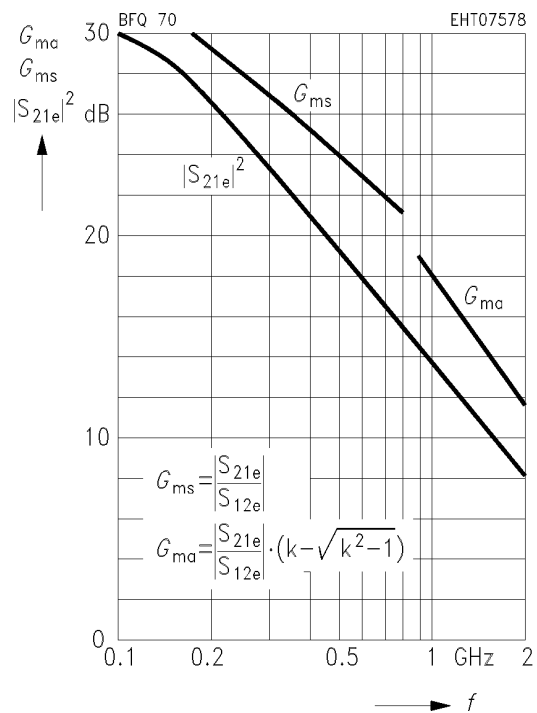

Common Emitter S Parameters

<i>f</i>	<i>S</i> ₁₁		<i>S</i> ₂₁		<i>S</i> ₁₂		<i>S</i> ₂₂	
	MAG	ANG	MAG	ANG	MAG	ANG	MAG	ANG
0.1	0.92	- 23	7.00	165	0.025	77	0.98	- 8
0.2	0.89	- 45	6.42	150	0.049	65	0.93	- 16
0.3	0.84	- 65	5.74	137	0.068	55	0.87	- 22
0.4	0.80	- 82	5.21	126	0.081	46	0.81	- 28
0.6	0.74	- 110	4.14	109	0.096	34	0.71	- 34
0.8	0.71	- 130	3.35	95	0.103	26	0.65	- 38
1.0	0.69	- 146	2.78	85	0.105	20	0.61	- 41
1.2	0.68	- 158	2.39	76	0.105	17	0.58	- 44
1.5	0.67	- 174	1.96	64	0.104	14	0.55	- 49
1.8	0.68	174	1.66	53	0.102	13	0.54	- 55
2.0	0.69	167	1.51	47	0.100	14	0.53	- 60
2.5	0.70	152	1.24	33	0.100	19	0.51	- 73
3.0	0.72	138	1.05	20	0.107	24	0.51	- 87

*I*_C = 2 mA, *V*_{CE} = 6 V, *Z*₀ = 50 Ω

*S*₁₁, *S*₂₂ = *f* (*f*)

*I*_C = 2 mA, *V*_{CE} = 6 V, *Z*₀ = 50 Ω

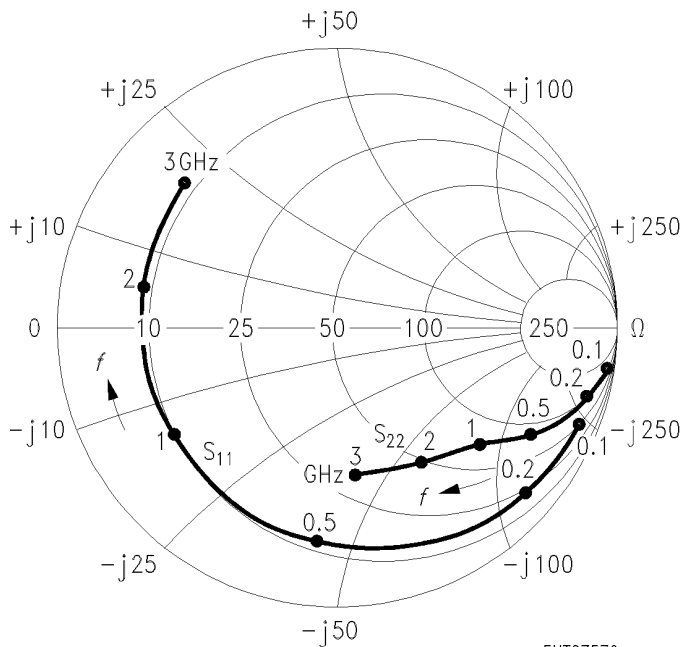

EHT07579

*S*₁₂, *S*₂₁ = *f* (*f*)

*I*_C = 2 mA, *V*_{CE} = 6 V, *Z*₀ = 50 Ω

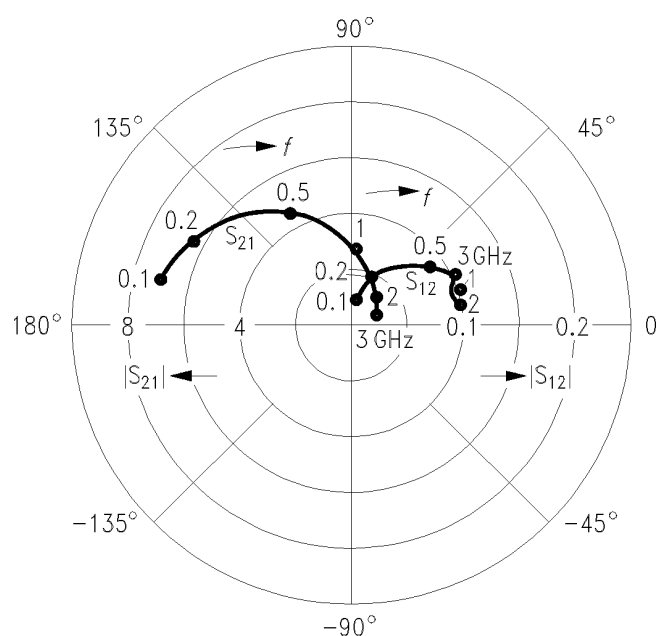

EHT07580

Common Emitter S Parameters (continued)

<i>f</i>	<i>S</i> ₁₁		<i>S</i> ₂₁		<i>S</i> ₁₂		<i>S</i> ₂₂	
	MAG	ANG	MAG	ANG	MAG	ANG	MAG	ANG
0.1	0.84	- 35	14.47	159	0.023	73	0.95	- 14
0.2	0.78	- 66	12.38	139	0.042	58	0.83	- 26
0.3	0.72	- 90	10.21	125	0.053	47	0.72	- 33
0.4	0.69	- 109	8.66	114	0.060	40	0.63	- 37
0.6	0.65	- 135	6.32	99	0.068	34	0.52	- 42
0.8	0.63	- 152	4.90	88	0.072	31	0.46	- 44
1.0	0.63	- 165	3.97	79	0.075	30	0.43	- 45
1.2	0.63	- 175	3.38	72	0.079	30	0.40	- 47
1.5	0.63	173	2.74	62	0.083	31	0.38	- 51
1.8	0.63	164	2.29	53	0.090	33	0.37	- 56
2.0	0.65	158	2.07	48	0.095	34	0.36	- 61
2.5	0.66	145	1.70	35	0.109	36	0.34	- 73
3.0	0.69	133	1.44	23	0.127	36	0.34	- 87

*I*_C = 5 mA, *V*_{CE} = 6 V, *Z*₀ = 50 Ω

*S*₁₁, *S*₂₂ = *f* (*f*)

*I*_C = 5 mA, *V*_{CE} = 6 V, *Z*₀ = 50 Ω

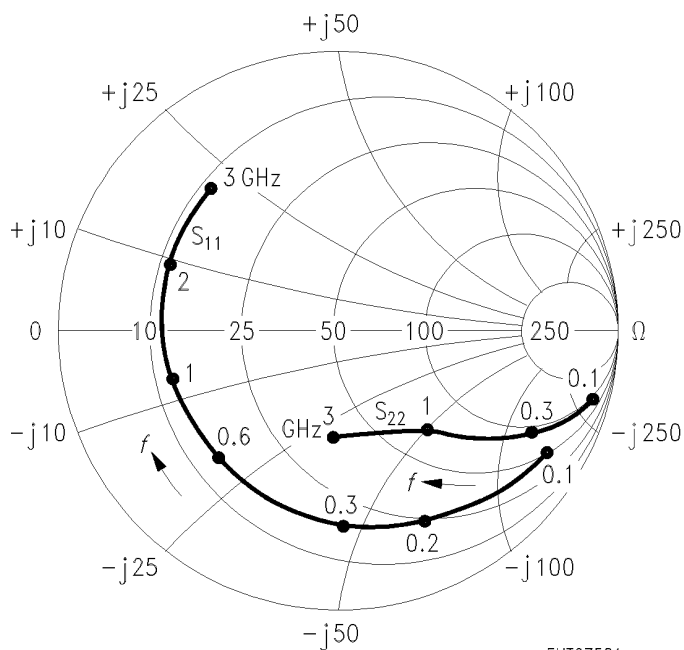

EHT07581

*S*₁₂, *S*₂₁ = *f* (*f*)

*I*_C = 5 mA, *V*_{CE} = 6 V, *Z*₀ = 50 Ω

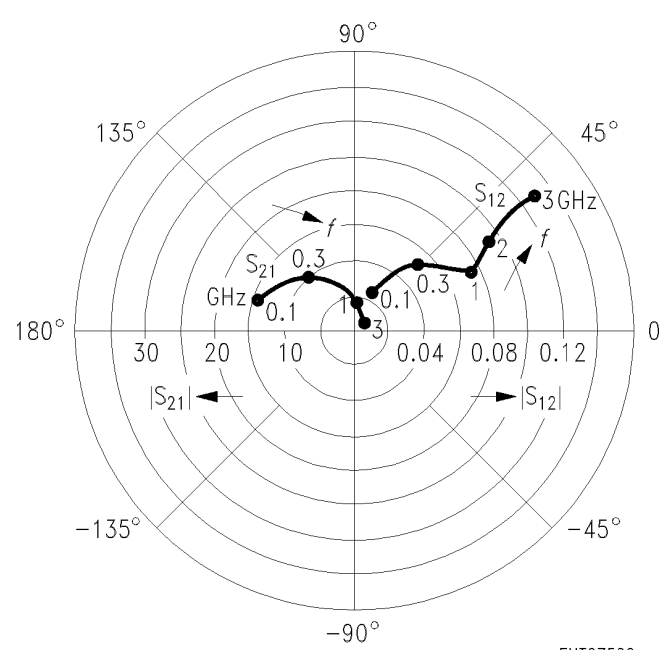

EHT07582

Common Emitter S Parameters (continued)

<i>f</i>	<i>S</i> ₁₁		<i>S</i> ₂₁		<i>S</i> ₁₂		<i>S</i> ₂₂		
	GHZ	MAG	ANG	MAG	ANG	MAG	ANG	MAG	ANG
<i>I</i> _C = 10 mA, <i>V</i> _{CE} = 6 V, <i>Z</i> ₀ = 50 Ω									
0.1	0.73	- 50	22.77	151	0.021	65	0.89	- 21	
0.2	0.67	- 89	17.57	129	0.034	52	0.71	- 34	
0.3	0.63	- 114	13.44	115	0.041	43	0.57	- 41	
0.4	0.62	- 132	10.84	105	0.045	41	0.49	- 44	
0.6	0.60	- 153	7.56	92	0.051	39	0.39	- 45	
0.8	0.60	- 167	5.75	83	0.057	40	0.35	- 46	
1.0	0.61	- 177	4.62	76	0.062	41	0.32	- 47	
1.2	0.61	175	3.90	70	0.068	43	0.30	- 48	
1.5	0.61	165	3.15	60	0.078	44	0.29	- 51	
1.8	0.62	157	2.62	52	0.089	44	0.28	- 56	
2.0	0.64	152	2.37	47	0.096	44	0.27	- 61	
2.5	0.65	141	1.94	35	0.117	44	0.25	- 73	
3.0	0.68	130	1.65	24	0.138	41	0.25	- 88	

*S*₁₁, *S*₂₂ = *f* (*f*)

*I*_C = 10 mA, *V*_{CE} = 6 V, *Z*₀ = 50 Ω

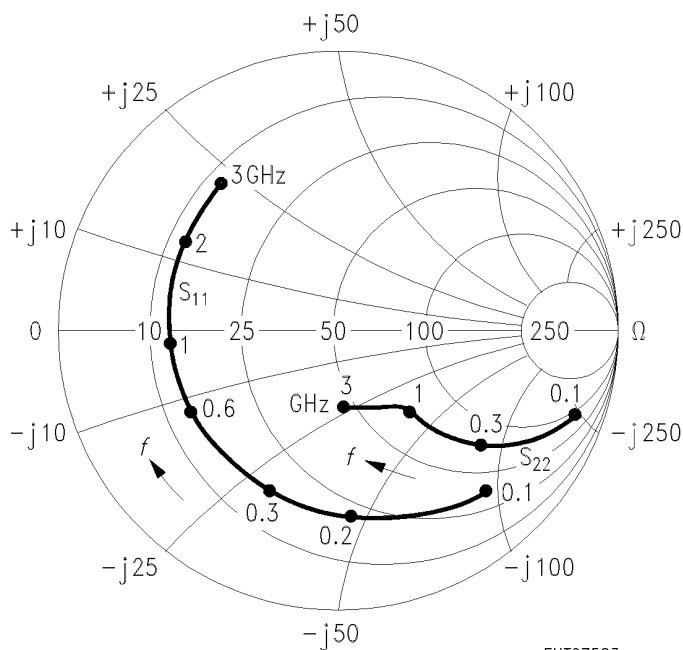

EHT07583

*S*₁₂, *S*₂₁ = *f* (*f*)

*I*_C = 10 mA, *V*_{CE} = 6 V, *Z*₀ = 50 Ω

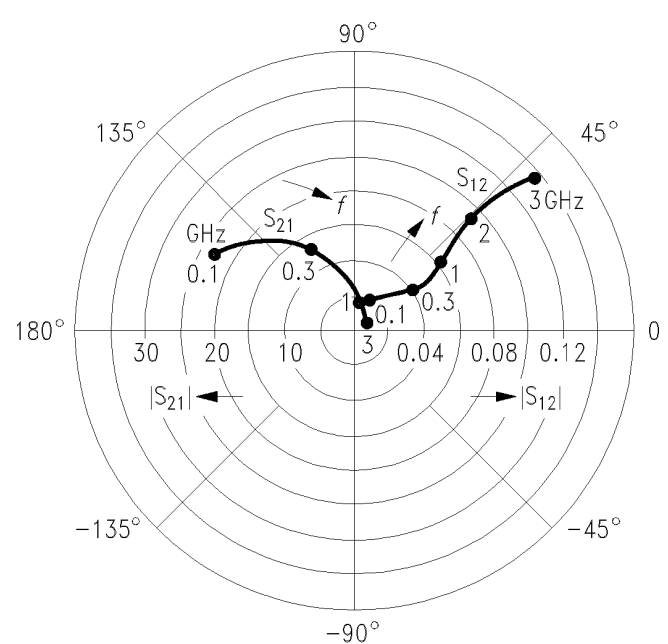

EHT07584

Common Emitter S Parameters (continued)

<i>f</i>	<i>S</i> ₁₁		<i>S</i> ₂₁		<i>S</i> ₁₂		<i>S</i> ₂₂	
	MAG	ANG	MAG	ANG	MAG	ANG	MAG	ANG
0.1	0.67	- 62	27.86	146	0.019	64	0.84	- 25
0.2	0.62	- 104	20.01	123	0.029	49	0.63	- 38
0.3	0.59	- 128	14.73	110	0.035	44	0.50	- 43
0.4	0.60	- 143	11.63	101	0.038	43	0.42	- 44
0.6	0.59	- 162	7.97	89	0.045	44	0.34	- 45
0.8	0.59	- 173	6.02	81	0.051	46	0.30	- 45
1.0	0.60	178	4.82	75	0.058	48	0.28	- 45
1.2	0.60	171	4.07	68	0.065	49	0.27	- 47
1.5	0.61	162	3.28	60	0.077	50	0.25	- 50
1.8	0.62	154	2.73	52	0.090	49	0.25	- 55
2.0	0.63	150	2.47	47	0.097	49	0.24	- 60
2.5	0.65	139	2.02	35	0.120	47	0.22	- 72
3.0	0.68	128	1.71	24	0.142	43	0.22	- 87

*I*_C = 15 mA, *V*_{CE} = 6 V, *Z*₀ = 50 Ω

*S*₁₁, *S*₂₂ = *f* (*f*)

*I*_C = 15 mA, *V*_{CE} = 6 V, *Z*₀ = 50 Ω

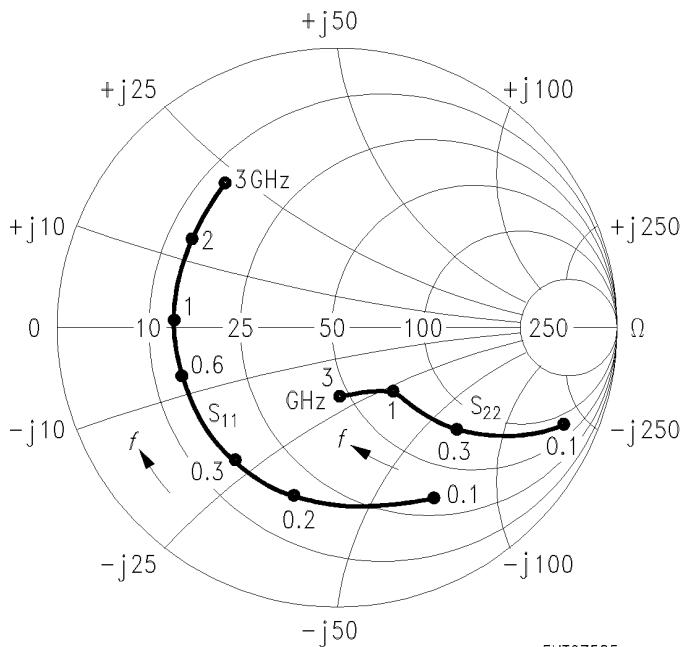

EHT07585

*S*₁₂, *S*₂₁ = *f* (*f*)

*I*_C = 15 mA, *V*_{CE} = 6 V, *Z*₀ = 50 Ω

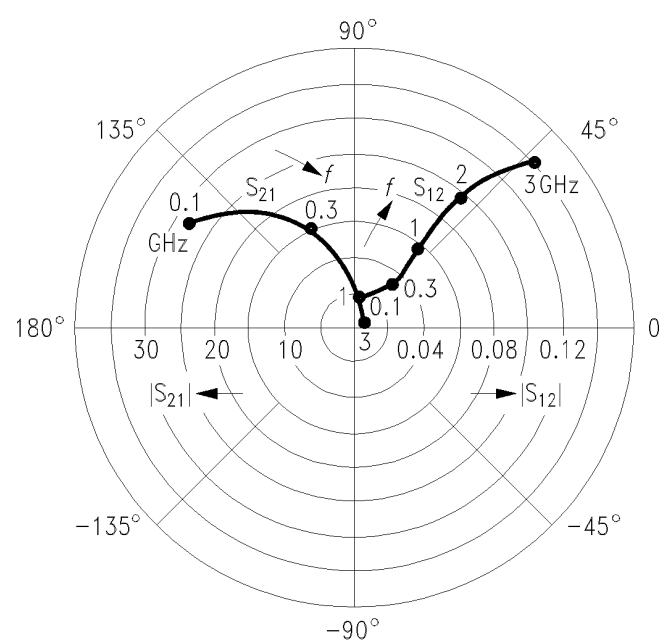

EHT07586

Common Emitter S Parameters (continued)

<i>f</i>	<i>S</i> ₁₁		<i>S</i> ₂₁		<i>S</i> ₁₂		<i>S</i> ₂₂	
	MAG	ANG	MAG	ANG	MAG	ANG	MAG	ANG
GHz								
<i>I</i> _C = 20 mA, <i>V</i> _{CE} = 6 V, <i>Z</i> ₀ = 50 Ω								
0.1	0.63	- 71	31.01	142	0.017	59	0.81	- 28
0.2	0.60	- 113	21.18	119	0.026	48	0.58	- 40
0.3	0.58	- 136	15.24	107	0.031	45	0.45	- 43
0.4	0.59	- 150	11.90	98	0.034	45	0.38	- 44
0.6	0.59	- 166	8.08	88	0.041	47	0.32	- 43
0.8	0.59	- 177	6.09	80	0.048	50	0.29	- 43
1.0	0.60	175	4.87	74	0.056	52	0.27	- 44
1.2	0.60	169	4.11	68	0.064	53	0.26	- 45
1.5	0.61	160	3.31	59	0.076	53	0.25	- 48
1.8	0.62	153	2.75	51	0.089	52	0.24	- 54
2.0	0.64	149	2.49	47	0.098	51	0.23	- 58
2.5	0.65	138	2.03	35	0.120	49	0.21	- 70
3.0	0.68	128	1.72	24	0.143	44	0.21	- 86

*S*₁₁, *S*₂₂ = *f* (*f*)

*I*_C = 20 mA, *V*_{CE} = 6 V, *Z*₀ = 50 Ω

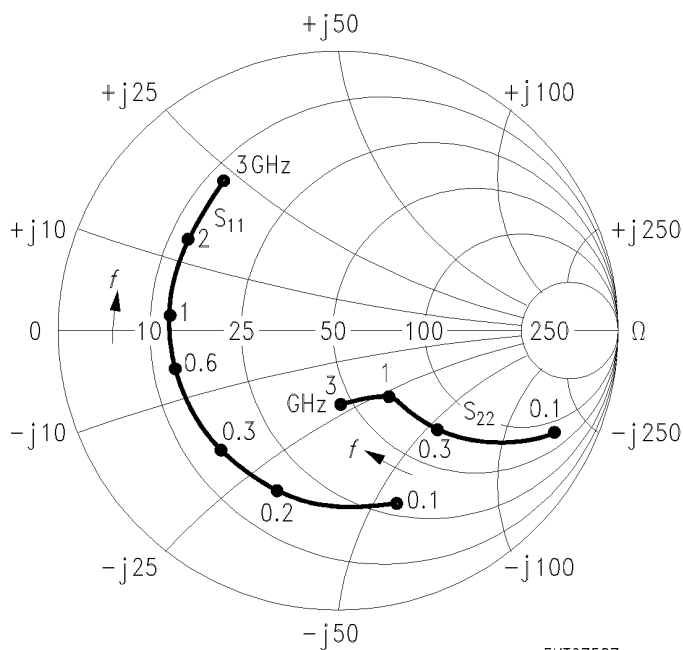

EHT07587

*S*₁₂, *S*₂₁ = *f* (*f*)

*I*_C = 20 mA, *V*_{CE} = 6 V, *Z*₀ = 50 Ω

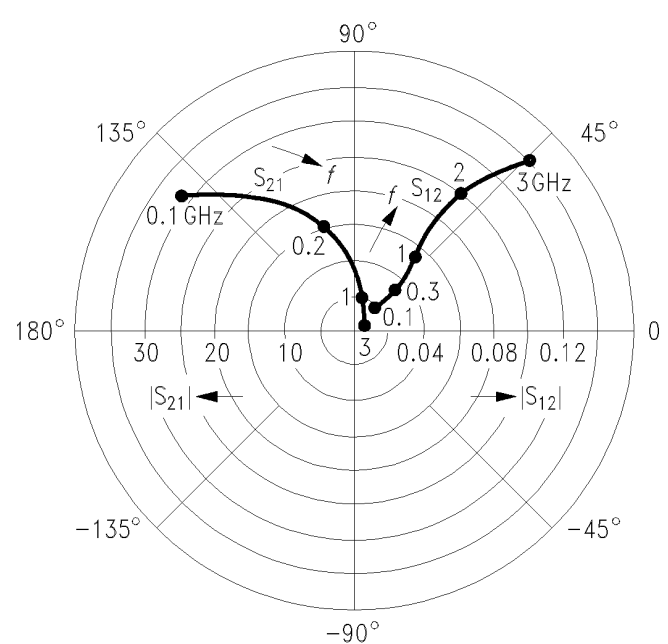

EHT07588

Common Emitter S Parameters (continued)

<i>f</i>	<i>S</i> ₁₁		<i>S</i> ₂₁		<i>S</i> ₁₂		<i>S</i> ₂₂	
	MAG	ANG	MAG	ANG	MAG	ANG	MAG	ANG
0.1	0.75	- 45	22.64	153	0.018	67	0.91	- 18
0.2	0.69	- 83	17.84	131	0.030	53	0.75	- 29
0.3	0.63	- 109	13.82	117	0.037	45	0.63	- 34
0.4	0.62	- 127	11.23	107	0.041	42	0.55	- 36
0.6	0.59	- 149	7.88	93	0.046	40	0.46	- 37
0.8	0.59	- 164	6.01	84	0.051	41	0.42	- 37
1.0	0.59	- 174	4.83	77	0.056	43	0.40	- 38
1.2	0.59	178	4.09	70	0.061	44	0.38	- 40
1.5	0.59	167	3.29	61	0.070	46	0.37	- 43
1.8	0.60	159	2.75	53	0.080	47	0.37	- 48
2.0	0.62	153	2.49	48	0.087	47	0.36	- 52
2.5	0.63	142	2.03	36	0.106	47	0.34	- 62
3.0	0.66	131	1.73	25	0.126	45	0.33	- 75

*I*_C = 10 mA, *V*_{CE} = 10 V, *Z*₀ = 50 Ω

*S*₁₁, *S*₂₂ = *f* (*f*)

*I*_C = 10 mA, *V*_{CE} = 10 V, *Z*₀ = 50 Ω

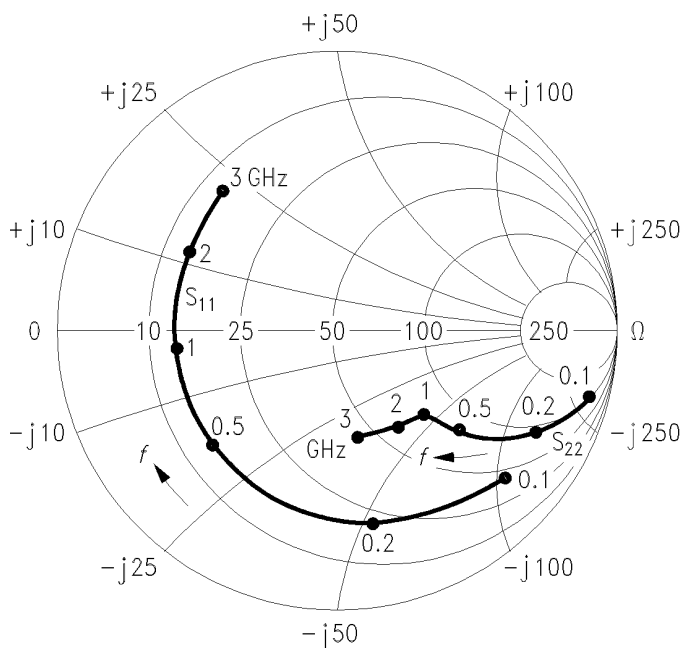

EHT07589

*S*₁₂, *S*₂₁ = *f* (*f*)

*I*_C = 10 mA, *V*_{CE} = 10 V, *Z*₀ = 50 Ω

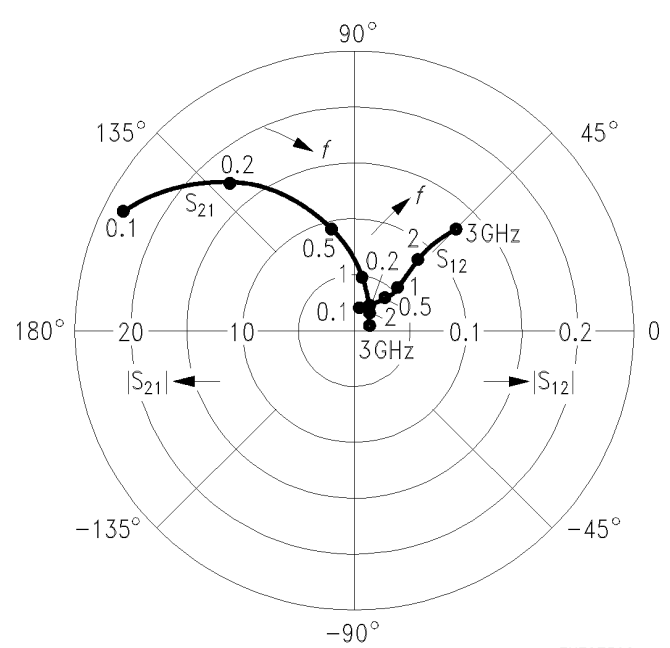

EHT07590



LittleDiode supplies new, hard to find or obsolete electronic components and semiconductors all over the world.

With over two million different components listed you are sure to find the part you need.

Feel free to visit us today at our online store:

LittleDiode.com

Looking forward to providing you with the best possible service.