



## Silicon NPN Planar RF Transistor

Electrostatic sensitive device.  
Observe precautions for handling.



### Applications

Wide band amplifier up to GHz range.

### Features

- High power gain
- Low noise figure
- High transition frequency

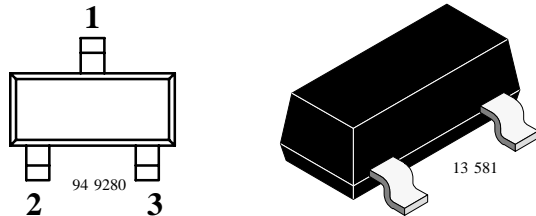

BFR92A Marking: +P2  
Plastic case (SOT 23)  
1 = Collector, 2 = Base, 3 = Emitter

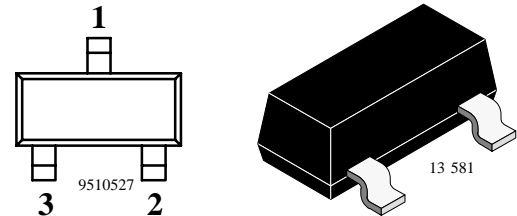

BFR92AR Marking: +P5  
Plastic case (SOT 23)  
1 = Collector, 2 = Base, 3 = Emitter

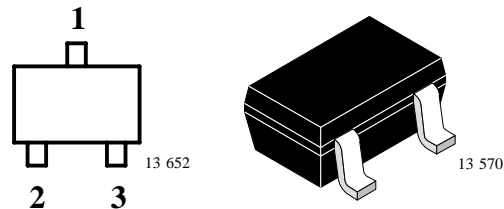

BFR92AW Marking: WP2  
Plastic case (SOT 323)  
1 = Collector, 2 = Base, 3 = Emitter

### Absolute Maximum Ratings

$T_{amb} = 25^{\circ}\text{C}$ , unless otherwise specified

Parameter	Test Conditions	Symbol	Value	Unit
Collector-base voltage		$V_{CBO}$	20	V
Collector-emitter voltage		$V_{CEO}$	15	V
Emitter-base voltage		$V_{EBO}$	2	V
Collector current		$I_C$	30	mA
Total power dissipation	$T_{amb} \leq 60^{\circ}\text{C}$	$P_{tot}$	200	mW
Junction temperature		$T_j$	150	$^{\circ}\text{C}$
Storage temperature range		$T_{stg}$	-65 to +150	$^{\circ}\text{C}$

### Maximum Thermal Resistance

$T_{amb} = 25^{\circ}\text{C}$ , unless otherwise specified

Parameter	Test Conditions	Symbol	Value	Unit
Junction ambient	on glass fibre printed board (25 x 20 x 1.5) mm <sup>3</sup> plated with 35μm Cu	$R_{thJA}$	450	K/W

### Electrical DC Characteristics

$T_{amb} = 25^{\circ}\text{C}$ , unless otherwise specified

Parameter	Test Conditions	Symbol	Min	Typ	Max	Unit
Collector cut-off current	$V_{CE} = 20\text{ V}$ , $V_{BE} = 0$	$I_{CES}$			100	μA
Collector-base cut-off current	$V_{CB} = 10\text{ V}$ , $I_E = 0$	$I_{CBO}$			100	nA
Emitter-base cut-off current	$V_{EB} = 2\text{ V}$ , $I_C = 0$	$I_{EBO}$			10	μA
Collector-emitter breakdown voltage	$I_C = 1\text{ mA}$ , $I_B = 0$	$V_{(BR)CEO}$	15			V
DC forward current transfer ratio	$V_{CE} = 10\text{ V}$ , $I_C = 14\text{ mA}$	$h_{FE}$	65	100	150	

### Electrical AC Characteristics

$T_{amb} = 25^{\circ}\text{C}$ , unless otherwise specified

Parameter	Test Conditions	Symbol	Min	Typ	Max	Unit
Transition frequency	$V_{CE} = 10\text{ V}$ , $I_C = 14\text{ mA}$ , $f = 500\text{ MHz}$	$f_T$		6		GHz
Collector-base capacitance	$V_{CB} = 10\text{ V}$ , $f = 1\text{ MHz}$	$C_{cb}$		0.3		pF
Collector-emitter capacitance	$V_{CE} = 10\text{ V}$ , $f = 1\text{ MHz}$	$C_{ce}$		0.15		pF
Emitter-base capacitance	$V_{EB} = 0.5\text{ V}$ , $f = 1\text{ MHz}$	$C_{eb}$		0.65		pF
Noise figure	$V_{CE} = 10\text{ V}$ , $I_C = 2\text{ mA}$ , $Z_S = 50\ \Omega$ , $f = 800\text{ MHz}$	F		1.8		dB
Power gain	$V_{CE} = 10\text{ V}$ , $Z_S = 50\ \Omega$ , $Z_L = Z_{Lopt}$ , $I_C = 14\text{ mA}$ , $f = 800\text{ MHz}$	$G_{pe}$		16		dB
Linear output voltage – two tone intermodulation test	$V_{CE} = 10\text{ V}$ , $I_C = 14\text{ mA}$ , $d_{IM} = 60\text{ dB}$ , $f_1 = 806\text{ MHz}$ , $f_2 = 810\text{ MHz}$ , $Z_S = Z_L = 50\ \Omega$	$V_1 = V_2$		120		mV
Third order intercept point	$V_{CE} = 10\text{ V}$ , $I_C = 14\text{ mA}$ , $f = 800\text{ MHz}$	$IP_3$		24		dBm



## Common Emitter S-Parameters

$Z_0 = 50 \Omega$ ,  $T_{amb} = 25^\circ\text{C}$ , unless otherwise specified

$V_{CE}/V$	$I_C/mA$	f/MHz	S11		S21		S12		S22	
			LIN MAG	ANG	LIN MAG	ANG	LIN MAG	ANG	LIN MAG	ANG
				deg		deg		deg		deg
5	2	100	0.902	-17.5	6.38	164.6	0.025	79.9	0.978	-7.6
		300	0.761	-50.2	5.51	137.8	0.064	63.1	0.859	-19.3
		500	0.577	-76.8	4.48	117.8	0.086	53.7	0.736	-24.2
		800	0.399	-105.3	3.28	98.9	0.104	49.7	0.642	-25.3
		1000	0.339	-121.9	2.79	90.0	0.114	50.3	0.618	-26.0
		1200	0.303	-138.1	2.45	82.1	0.124	51.1	0.603	-28.0
		1500	0.284	-163.3	2.07	71.4	0.140	53.1	0.577	-31.2
		1800	0.272	172.9	1.79	62.5	0.157	55.5	0.560	-33.9
	2000	0.278	159.4	1.65	57.3	0.171	56.6	0.558	-36.0	
	5	100	0.783	-27.2	12.84	155.8	0.023	76.3	0.934	-12.7
		300	0.534	-69.6	9.12	122.8	0.052	61.9	0.711	-25.1
		500	0.351	-97.6	6.41	104.8	0.068	59.5	0.580	-25.6
		800	0.220	-128.3	4.28	89.8	0.091	61.1	0.518	-22.1
		1000	0.188	-145.2	3.53	82.9	0.107	62.5	0.515	-22.2
		1200	0.175	-162.0	3.04	76.5	0.124	62.8	0.510	-24.1
		1500	0.189	175.1	2.51	67.8	0.149	63.0	0.494	-27.3
		1800	0.200	153.5	2.16	60.2	0.175	62.4	0.483	-30.0
	2000	0.214	140.6	1.98	55.8	0.194	61.6	0.481	-32.6	
	10	100	0.641	-38.1	19.40	146.3	0.020	73.2	0.869	-17.6
		300	0.362	-85.8	11.09	112.0	0.043	65.2	0.597	-26.0
		500	0.229	-116.7	7.27	97.3	0.062	66.3	0.496	-22.9
		800	0.148	-151.6	4.69	84.9	0.089	68.1	0.465	-18.1
		1000	0.136	-168.5	3.83	79.0	0.108	68.1	0.473	-18.4
		1200	0.133	176.8	3.27	73.4	0.127	67.8	0.473	-20.6
		1500	0.160	158.3	2.70	65.7	0.156	66.5	0.461	-24.6
		1800	0.183	139.4	2.30	58.9	0.184	64.8	0.452	-27.4
	2000	0.198	130.4	2.12	54.8	0.203	63.5	0.450	-30.1	

# BFR92A/BFR92AR/BFR92AW



Vishay Semiconductors

V <sub>CE</sub> /V	I <sub>C</sub> /mA	f/MHz	S11		S21		S12		S22	
			LIN MAG	ANG	LIN MAG	ANG	LIN MAG	ANG	LIN MAG	ANG
				deg		deg		deg		deg
5	14	100	0.566	-44.3	22.20	141.5	0.019	72.7	0.832	-19.4
		300	0.301	-94.2	11.58	108.1	0.041	67.5	0.560	-25.1
		500	0.195	-127.0	7.43	94.6	0.060	69.0	0.475	-20.9
		800	0.137	-164.6	4.78	83.2	0.089	70.1	0.456	-16.5
		1000	0.129	-179.9	3.88	77.6	0.109	69.9	0.466	-17.1
		1200	0.132	167.7	3.30	72.3	0.128	69.1	0.469	-19.4
		1500	0.162	153.1	2.72	64.9	0.157	67.5	0.456	-23.4
		1800	0.183	136.6	2.32	58.1	0.185	65.6	0.448	-26.3
	2000	0.204	127.4	2.13	54.1	0.205	64.1	0.446	-29.2	
	20	100	0.484	-52.5	24.55	136.0	0.018	72.0	0.788	-20.7
		300	0.251	-106.2	11.67	104.3	0.039	69.5	0.531	-22.8
		500	0.181	-141.8	7.37	92.1	0.058	71.5	0.466	-18.3
		800	0.144	-177.4	4.70	81.3	0.088	72.0	0.456	-14.4
		1000	0.138	169.3	3.82	76.0	0.108	71.4	0.469	-15.3
		1200	0.145	159.1	3.26	70.9	0.127	70.6	0.472	-18.1
		1500	0.179	148.3	2.67	63.7	0.157	68.4	0.461	-22.4
1800		0.202	133.7	2.28	57.0	0.185	66.4	0.453	-25.4	
2000	0.220	125.9	2.10	52.8	0.205	64.8	0.452	-28.4		
10	2	100	0.915	-16.2	6.32	165.5	0.020	80.5	0.981	-6.2
		300	0.780	-46.7	5.56	139.6	0.054	65.1	0.883	-16.1
		500	0.597	-71.2	4.57	119.9	0.073	55.8	0.778	-20.4
		800	0.405	-97.6	3.37	101.0	0.089	52.2	0.692	-21.6
		1000	0.339	-113.1	2.87	92.3	0.098	53.0	0.677	-22.4
		1200	0.294	-129.6	2.53	84.2	0.107	54.3	0.663	-24.0
		1500	0.261	-155.8	2.13	73.7	0.121	56.8	0.643	-27.0
		1800	0.240	179.2	1.84	64.8	0.136	59.2	0.630	-29.6
	2000	0.243	163.2	1.70	59.8	0.149	61.1	0.630	-31.4	
	5	100	0.816	-24.3	12.50	157.4	0.019	77.2	0.947	-10.3
		300	0.569	-62.7	9.15	125.3	0.044	63.6	0.761	-20.5
		500	0.372	-87.9	6.55	106.9	0.059	60.6	0.647	-21.1
		800	0.220	-114.2	4.41	91.6	0.079	62.3	0.592	-18.8
		1000	0.175	-129.6	3.63	84.6	0.093	63.9	0.590	-19.1
		1200	0.153	-145.8	3.13	78.3	0.107	64.8	0.589	-20.8
		1500	0.153	-175.7	2.59	69.7	0.129	65.5	0.576	-24.1
1800		0.157	158.0	2.22	62.1	0.152	65.5	0.567	-26.6	
2000	0.170	143.4	2.04	57.9	0.168	65.3	0.567	-28.7		



# BFR92A/BFR92AR/BFR92AW

Vishay Semiconductors

V <sub>CE</sub> /V	I <sub>C</sub> /mA	f/MHz	S11		S21		S12		S22	
			LIN MAG	ANG	LIN MAG	ANG	LIN MAG	ANG	LIN MAG	ANG
				deg		deg		deg		deg
10	10	100	0.696	-33.7	18.83	148.4	0.017	74.6	0.896	-13.8
		300	0.397	-75.7	11.20	114.4	0.038	66.4	0.666	-20.8
		500	0.237	-101.2	7.41	99.0	0.054	67.0	0.577	-18.6
		800	0.132	-130.2	4.81	86.4	0.078	68.9	0.553	-15.5
		1000	0.103	-149.3	3.92	80.4	0.094	69.4	0.560	-16.0
		1200	0.097	-165.8	3.35	75.0	0.111	69.5	0.561	-18.2
		1500	0.116	167.2	2.76	67.5	0.136	69.0	0.551	-21.9
		1800	0.133	141.3	2.36	60.4	0.160	67.9	0.545	-24.4
		2000	0.148	129.4	2.16	56.4	0.178	66.8	0.549	-27.1
	14	100	0.639	-38.8	21.41	143.8	0.016	73.2	0.866	-15.2
		300	0.339	-82.4	11.61	110.2	0.036	67.5	0.636	-19.8
		500	0.199	-110.0	7.52	96.3	0.053	69.4	0.562	-16.9
		800	0.113	-144.1	4.83	84.4	0.077	70.7	0.549	-14.2
		1000	0.093	160.9	3.93	78.9	0.094	71.1	0.556	-14.9
		1200	0.090	179.0	3.36	73.7	0.110	70.5	0.560	-17.3
		1500	0.118	158.6	2.76	66.4	0.136	69.8	0.550	-21.0
		1800	0.137	137.7	2.35	59.5	0.161	68.4	0.546	-24.0
		2000	0.155	125.7	2.16	55.6	0.178	67.4	0.548	-26.5
	20	100	0.576	-45.8	23.38	138.5	0.015	72.0	0.836	-15.8
		300	0.286	-91.7	11.55	106.1	0.034	69.0	0.620	-17.7
		500	0.177	-123.1	7.34	93.4	0.051	71.3	0.565	-14.7
		800	0.113	-161.1	4.69	82.2	0.075	72.4	0.557	-12.6
		1000	0.101	-177.3	3.81	77.1	0.092	72.4	0.568	-13.8
		1200	0.107	168.1	3.24	72.0	0.109	71.9	0.571	-16.4
		1500	0.136	152.5	2.67	64.8	0.134	70.9	0.564	-20.4
		1800	0.160	133.1	2.27	58.1	0.159	69.5	0.559	-23.5
		2000	0.181	124.2	2.09	54.0	0.176	68.4	0.560	-25.9

### Typical Characteristics ( $T_{amb} = 25^{\circ}\text{C}$ unless otherwise specified)

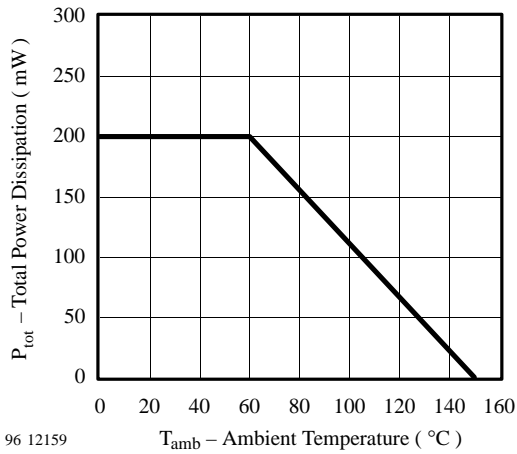

Figure 1. Total Power Dissipation vs. Ambient Temperature

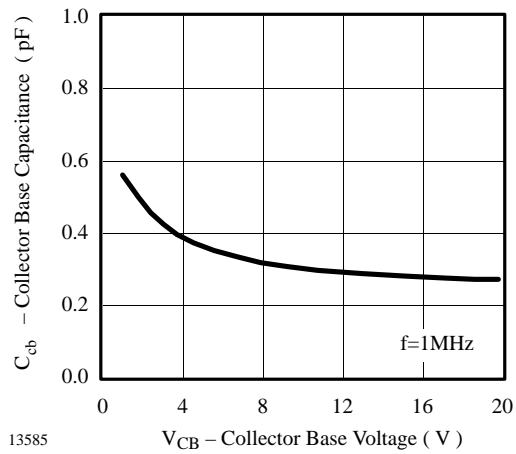

Figure 3. Collector Base Capacitance vs. Collector Base Voltage

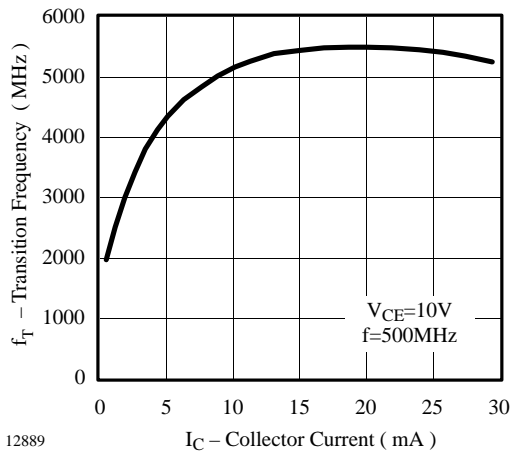

Figure 2. Transition Frequency vs. Collector Current

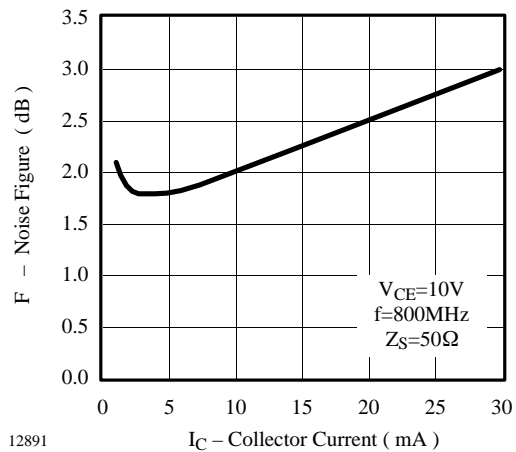

Figure 4. Noise Figure vs. Collector Current



$V_{CE} = 10 \text{ V}$ ,  $I_C = 14 \text{ mA}$ ,  $Z_0 = 50 \Omega$

$S_{11}$

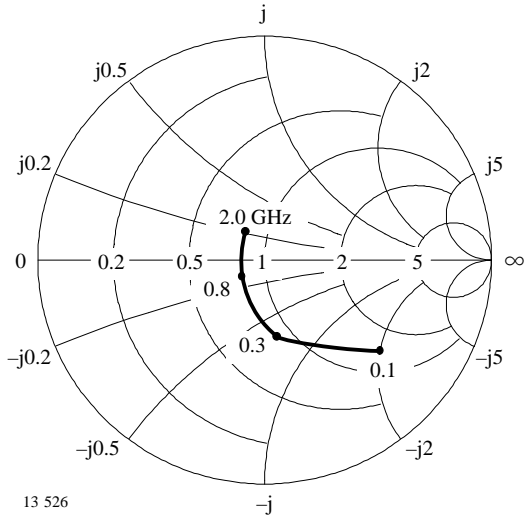

Figure 5. Input reflection coefficient

$S_{12}$

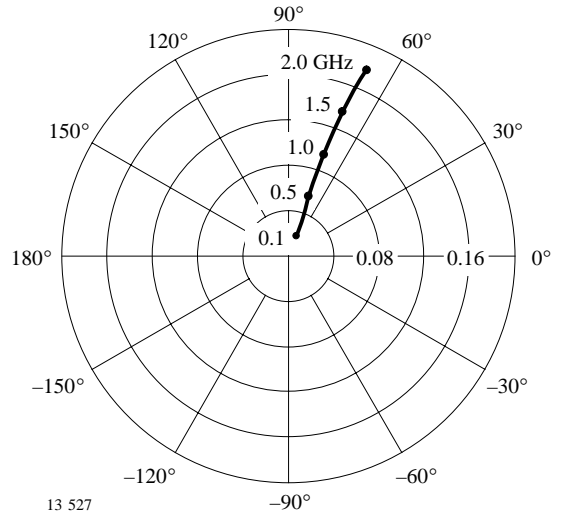

Figure 7. Reverse transmission coefficient

$S_{21}$

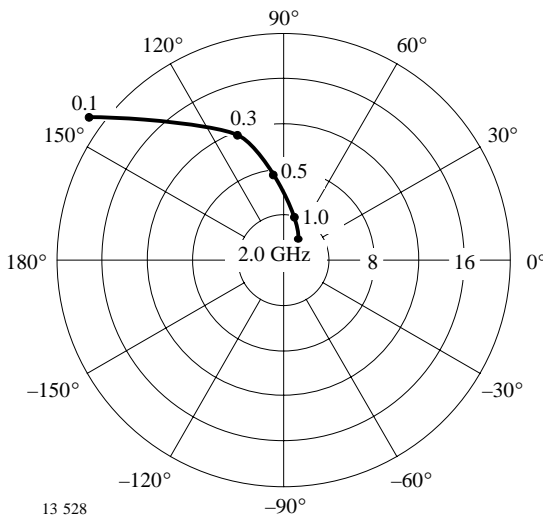

Figure 6. Forward transmission coefficient

$S_{22}$

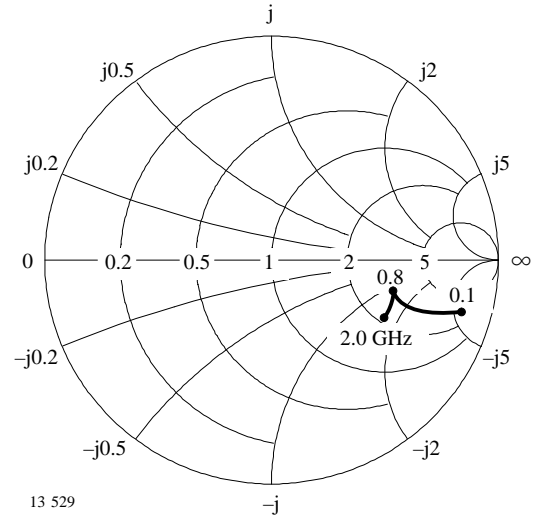
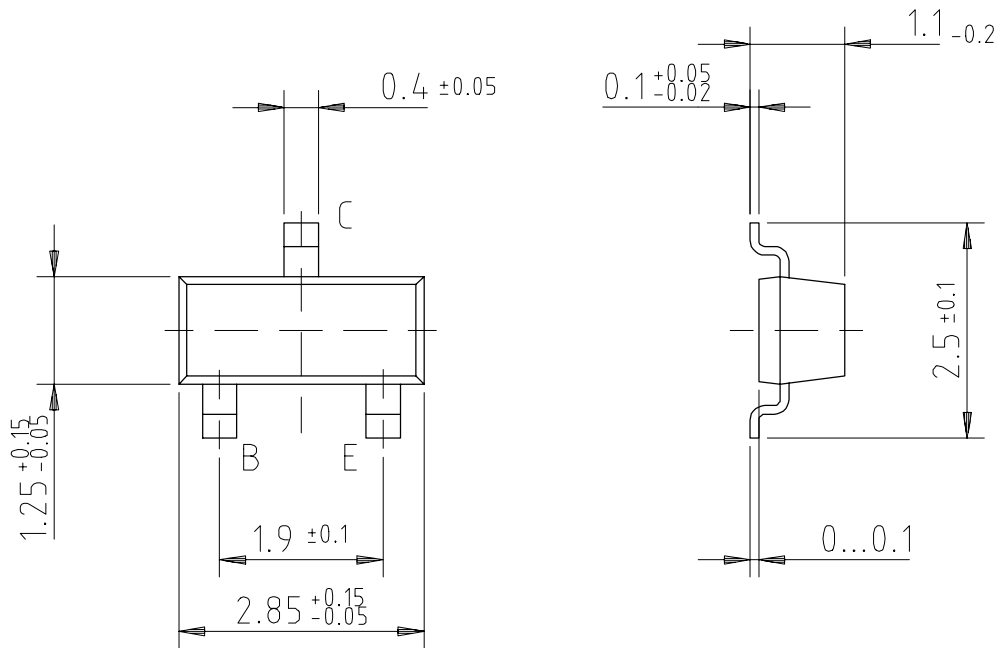
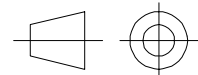

Figure 8. Output reflection coefficient

### Dimensions of BFR92A in mm



95 11346



technical drawings  
according to DIN  
specifications

### Dimensions of BFR92AR in mm

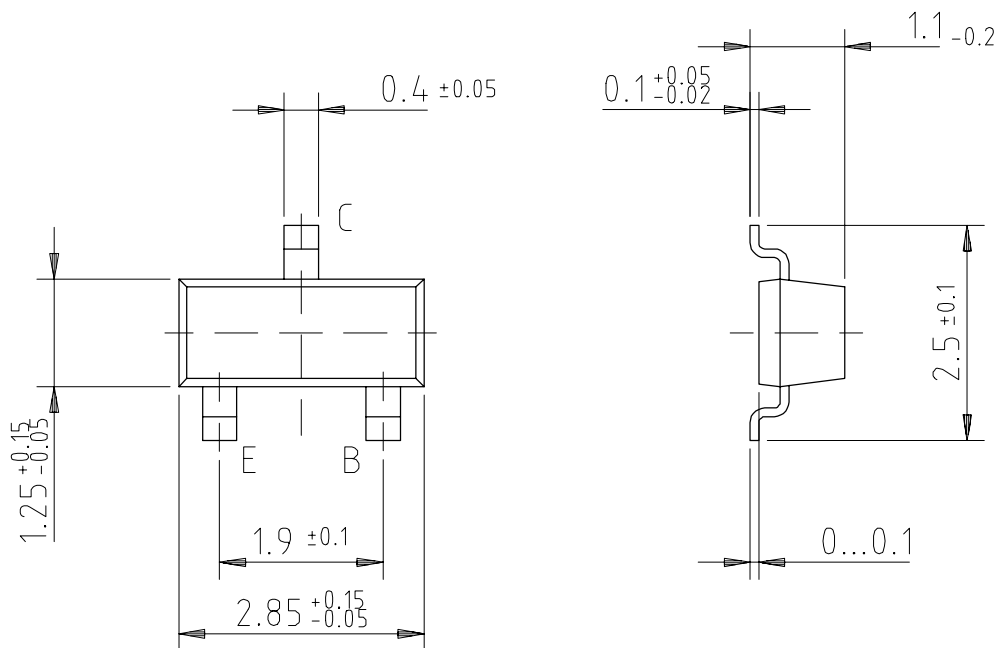

95 11347

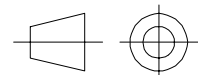

technical drawings  
according to DIN  
specifications



# BFR92A/BFR92AR/BFR92AW

Vishay Semiconductors

## Dimensions of BFR92AW in mm

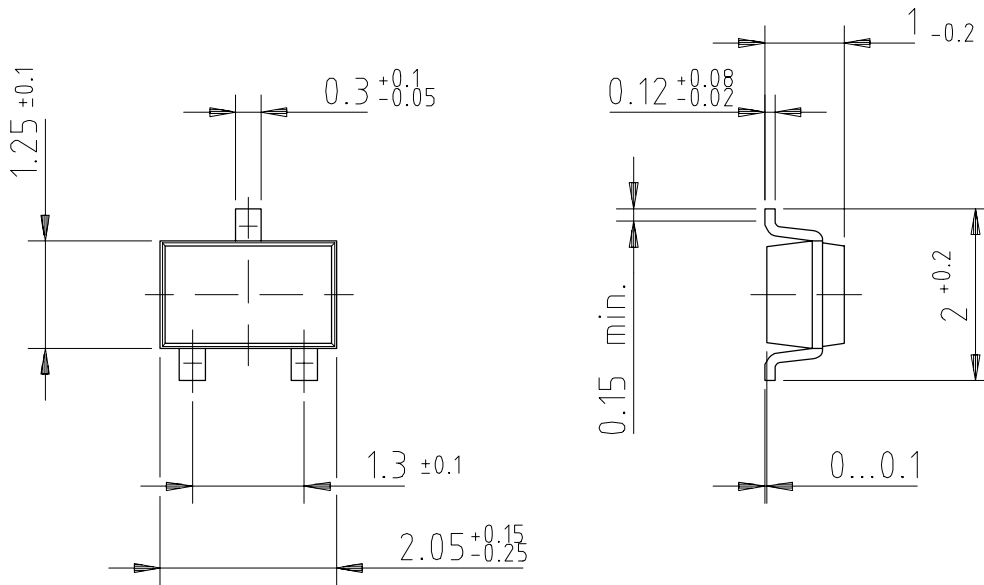

96 12236

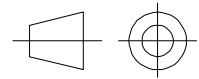

technical drawings  
according to DIN  
specifications



### Ozone Depleting Substances Policy Statement

It is the policy of **Vishay Semiconductor GmbH** to

1. Meet all present and future national and international statutory requirements.
2. Regularly and continuously improve the performance of our products, processes, distribution and operating systems with respect to their impact on the health and safety of our employees and the public, as well as their impact on the environment.

It is particular concern to control or eliminate releases of those substances into the atmosphere which are known as ozone depleting substances (ODSs).

The Montreal Protocol (1987) and its London Amendments (1990) intend to severely restrict the use of ODSs and forbid their use within the next ten years. Various national and international initiatives are pressing for an earlier ban on these substances.

**Vishay Semiconductor GmbH** has been able to use its policy of continuous improvements to eliminate the use of ODSs listed in the following documents.

1. Annex A, B and list of transitional substances of the Montreal Protocol and the London Amendments respectively
2. Class I and II ozone depleting substances in the Clean Air Act Amendments of 1990 by the Environmental Protection Agency (EPA) in the USA
3. Council Decision 88/540/EEC and 91/690/EEC Annex A, B and C (transitional substances) respectively.

**Vishay Semiconductor GmbH** can certify that our semiconductors are not manufactured with ozone depleting substances and do not contain such substances.

**We reserve the right to make changes to improve technical design and may do so without further notice.**

Parameters can vary in different applications. All operating parameters must be validated for each customer application by the customer. Should the buyer use Vishay-Semiconductors products for any unintended or unauthorized application, the buyer shall indemnify Vishay-Semiconductors against all claims, costs, damages, and expenses, arising out of, directly or indirectly, any claim of personal damage, injury or death associated with such unintended or unauthorized use.

Vishay Semiconductor GmbH, P.O.B. 3535, D-74025 Heilbronn, Germany  
Telephone: 49 (0)7131 67 2831, Fax number: 49 (0)7131 67 2423



LittleDiode supplies new, hard to find or obsolete electronic components and semiconductors all over the world.

With over two million different components listed you are sure to find the part you need.

Feel free to visit us today at our online store:

[LittleDiode.com](http://LittleDiode.com)

Looking forward to providing you with the best possible service.