

**NPN Silicon RF Transistor**

- For broadband amplifiers up to 1 GHz at collector currents from 1 mA to 20 mA

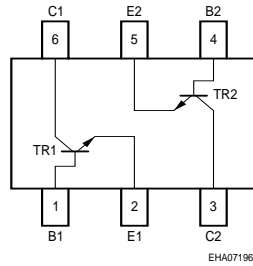
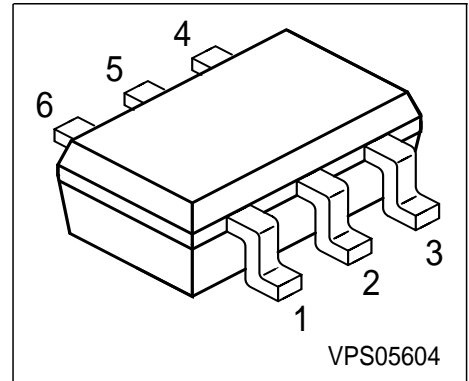

Type	Marking	Pin Configuration					Package	
BFS17S	MCs	1=B1	2=E1	3=C2	4=B2	5=E2	6=C1	SOT363

**Maximum Ratings**

Parameter	Symbol	Value	Unit
Collector-emitter voltage	$V_{CEO}$	15	V
Collector-base voltage	$V_{CBO}$	25	
Emitter-base voltage	$V_{EBO}$	2.5	
Collector current	$I_C$	25	mA
Peak collector current, $f = 10$ MHz	$I_{CM}$	50	
Total power dissipation $T_S \leq 93$ °C <sup>1)</sup>	$P_{tot}$	280	mW
Junction temperature	$T_j$	150	°C
Ambient temperature	$T_A$	-65 ... 150	
Storage temperature	$T_{stg}$	-65 ... 150	

**Thermal Resistance**

Junction - soldering point <sup>2)</sup>	$R_{thJS}$	$\leq 240$	K/W
--	------------	------------	-----

<sup>1</sup>  $T_S$  is measured on the collector lead at the soldering point to the pcb

<sup>2</sup> For calculation of  $R_{thJA}$  please refer to Application Note Thermal Resistance

**Electrical Characteristics** at  $T_A = 25^\circ\text{C}$ , unless otherwise specified.

Parameter	Symbol	Values			Unit
		min.	typ.	max.	
<b>DC characteristics</b>					
Collector-emitter breakdown voltage $I_C = 1 \text{ mA}, I_B = 0$	$V_{(BR)CEO}$	15	-	-	V
Collector-base cutoff current $V_{CB} = 10 \text{ V}, I_E = 0$ $V_{CB} = 25 \text{ V}, I_E = 0$	$I_{CBO}$	-	-	0.05 10	$\mu\text{A}$
Emitter-base cutoff current $V_{EB} = 2.5 \text{ V}, I_C = 0$	$I_{EBO}$	-	-	100	
DC current gain $I_C = 2 \text{ mA}, V_{CE} = 1 \text{ V}$ $I_C = 25 \text{ mA}, V_{CE} = 1 \text{ V}$	$h_{FE}$	20 20	- 70	150 -	-
Collector-emitter saturation voltage $I_C = 10 \text{ mA}, I_B = 1 \text{ mA}$	$V_{CEsat}$	-	0.1	0.4	V

**Electrical Characteristics** at  $T_A = 25^\circ\text{C}$ , unless otherwise specified.

Parameter	Symbol	Values			Unit
		min.	typ.	max.	
<b>AC characteristics</b>					
Transition frequency $I_C = 2 \text{ mA}$ , $V_{CE} = 5 \text{ V}$ , $f = 200 \text{ MHz}$ $I_C = 25 \text{ mA}$ , $V_{CE} = 5 \text{ V}$ , $f = 200 \text{ MHz}$	$f_T$	1 1.3	1.4 2.5	- -	GHz
Collector-base capacitance $V_{CB} = 5 \text{ V}$ , $f = 1 \text{ MHz}$	$C_{cb}$	-	0.55	0.8	pF
Collector-emitter capacitance $V_{CE} = 5 \text{ V}$ , $f = 1 \text{ MHz}$	$C_{ce}$	-	0.13	-	
Input capacitance $V_{EB} = 0.5 \text{ V}$ , $I_C = 0$ , $f = 1 \text{ MHz}$	$C_{ibo}$	-	1.45	-	
Output capacitance $V_{CE} = 5 \text{ V}$ , $V_{BE} = 0$ , $f = 1 \text{ MHz}$	$C_{obs}$	-	-	1.5	
Noise figure $I_C = 2 \text{ mA}$ , $V_{CE} = 5 \text{ V}$ , $f = 800 \text{ MHz}$ , $Z_S = 0 \Omega$	$F$	-	3.5	5	dB
Transducer gain $I_C = 20 \text{ mA}$ , $V_{CE} = 5 \text{ V}$ , $Z_S = Z_L = 50 \Omega$ , $f = 500 \text{ MHz}$	$ S_{21e} ^2$	-	12,7	-	
Linear output voltage $I_C = 14 \text{ mA}$ , $V_{CE} = 5 \text{ V}$ , $d_{im} = 60 \text{ dB}$ , $f_1 = 806 \text{ MHz}$ , $f_2 = 810 \text{ MHz}$ , $Z_S = Z_L = 50 \Omega$	$V_{01} = V_{02}$	-	100	-	mV
Third order intercept point $I_C = 200 \text{ mA}$ , $V_{CE} = 8 \text{ V}$ , $Z_S = Z_{Sopt}$ , $Z_L = Z_{Lopt}$ , $f = 900 \text{ MHz}$	$IP_3$	-	23	-	dBm

**Total power dissipation  $P_{tot} = f(T_S)$**

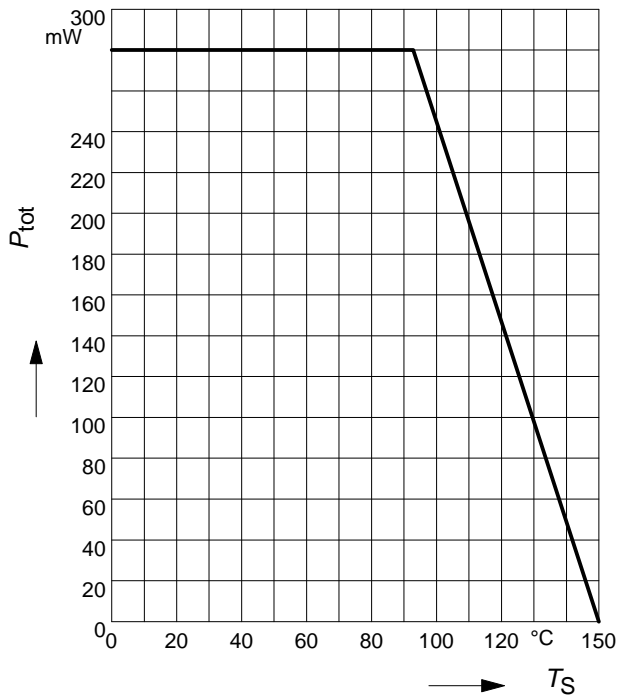

**Permissible Pulse Load  $R_{thJS} = f(t_p)$**

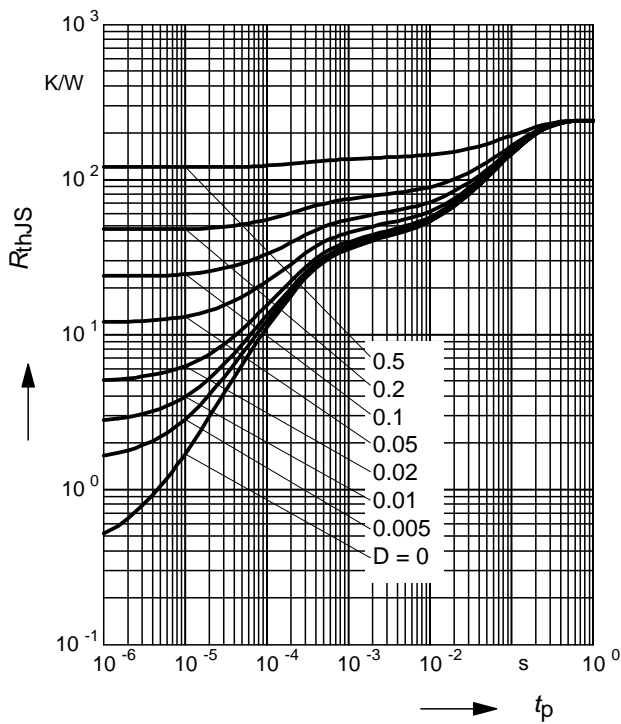

**Permissible Pulse Load**

$P_{totmax} / P_{totDC} = f(t_p)$

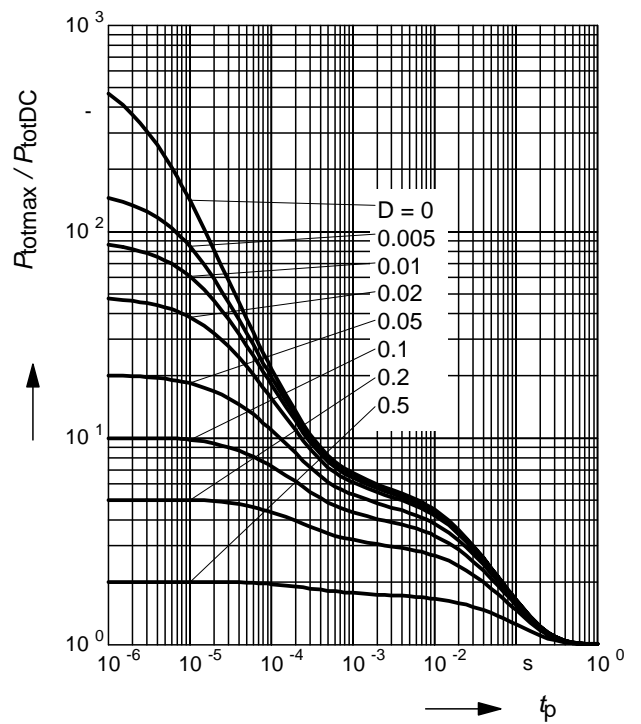

**Collector-base capacitance**  $C_{cb} = f(V_{CB})$   
 $f = 1\text{MHz}$

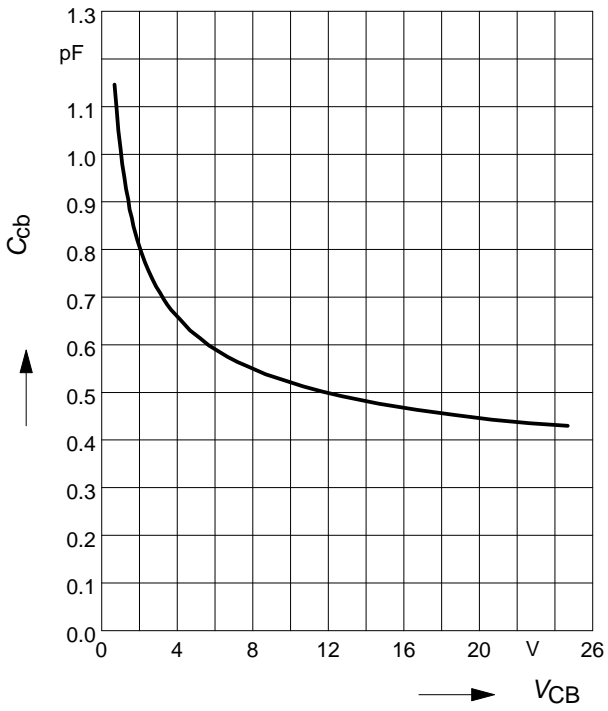

**Transition frequency**  $f_T = f(I_C)$

$V_{CE} = \text{Parameter}$

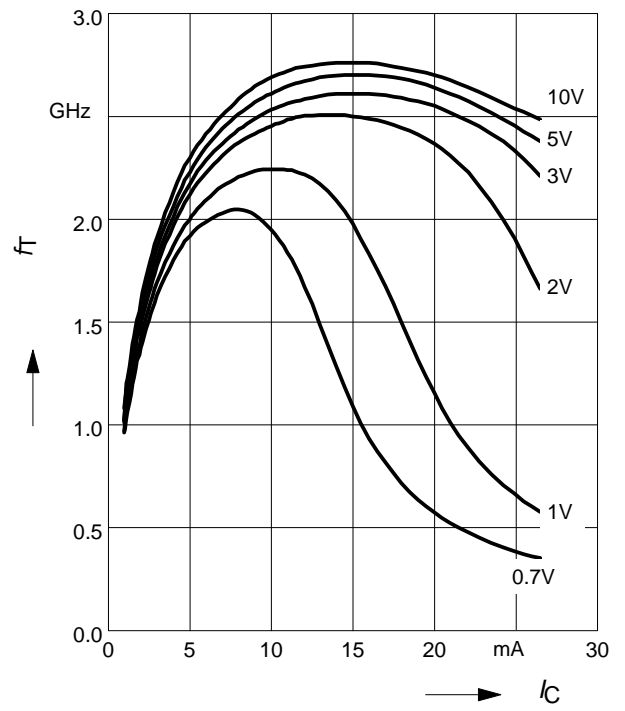



LittleDiode supplies new, hard to find or obsolete electronic components and semiconductors all over the world.

With over two million different components listed you are sure to find the part you need.

Feel free to visit us today at our online store:

[LittleDiode.com](http://LittleDiode.com)

Looking forward to providing you with the best possible service.