

**NPN Silicon Transistor for VHF Output Stages
in Broadband Amplifiers**

BFX 55

SIEMENS AKTIENGESELLSCHAFT

BFX 55 is an epitaxial NPN silicon planar transistor in a TO 39 case (5 C 3 DIN 41873). The collector has been electrically connected to the case. The transistor is especially suitable for use in VHF output stages of antenna channel and broadband amplifiers.

Type	Ordering code
BFX 55	Q60206-X55

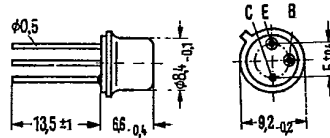

Approx weight 1.5 g Dimensions in mm

Maximum ratings

Collector-emitter voltage	V_{CE0}	40	V
Collector-base voltage	V_{CB0}	60	V
Emitter-base voltage	V_{EB0}	3.5	V
Collector current	I_C	400	mA
Base current	I_B	100	mA
Junction temperature	T_j	200	°C
Storage temperature range	T_{stg}	-65 to +175	°C
Total power dissipation ($T_{case} \leq 68^\circ\text{C}$)	P_{tot}	2.2	W

Thermal resistance

Junction to ambient air	R_{thJA}	≤ 220	K/W
Junction to case	R_{thJC}	≤ 60	K/W

Test circuit for power gain $f = 200$ MHz

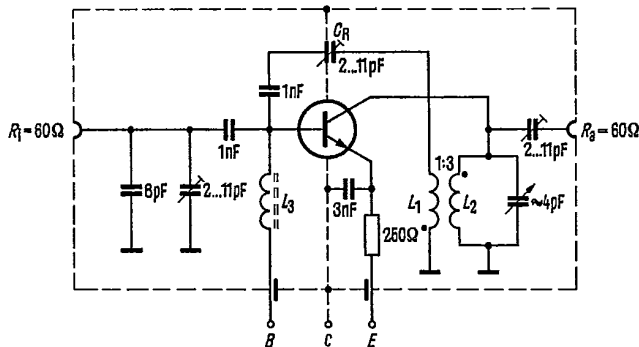

(Transistor cooled by mounted radiator of $R_{th} = 30$ K/W)

- L_1 1 turn 0.5 CuLS (enameled, silk insulated copper wire)
- L_2 3 turns 6.5 \varnothing , spacing 1.5 mm, 1 \varnothing silvered Cu
- L_3 20 turns 0.5 CuLS on SIFERRIT core B 63310-A 3004-X 025 transformed load resistance $R_L = 450 \Omega$

SIEMENS AKTIENGESELLSCHAFT

Static characteristics ($T_{amb} = 25^{\circ}\text{C}$)

Collector cutoff current ($V_{CB0} = 40\text{ V}$)	I_{CB0}	≤ 50	nA
Collector-base breakdown voltage ($I_{CBS} = 100\ \mu\text{A}$)	$V_{(BR)CBS}$	> 60	V
DC current gain ($I_C = 50\text{ mA}$; $V_{CE} = 5\text{ V}$)	h_{FE}	30 to 160	-

Dynamic characteristics ($T_{amb} = 25^{\circ}\text{C}$)

Transition frequency ($I_C = 50\text{ mA}$; $V_{CE} = 15\text{ V}$)	f_T	700	MHz
Reverse transfer capacitance ($I_C = 1\text{ mA}$; $V_{CE} = 10\text{ V}$; $f = 1\text{ MHz}$)	C_{12e}	2.5 (<3.5)	pF
Power gain ($f = 200\text{ MHz}$; $R_L = 450\ \Omega$; see test circuit) ($I_C = 40\text{ mA}$; $V_{CB} = 25\text{ V}$)	G_{pe}	16	dB
Output voltage ($I_C = 40\text{ mA}$; $V_{CB} = 25\text{ V}$; $d_{IM} = 30\text{ dB}$; $R_L = 60\ \Omega$)	$V_{o\ rms}$	2.4	V

Total perm. power dissipation versus temperature

$P_{tot} = f(T)$; R_{th} = parameter

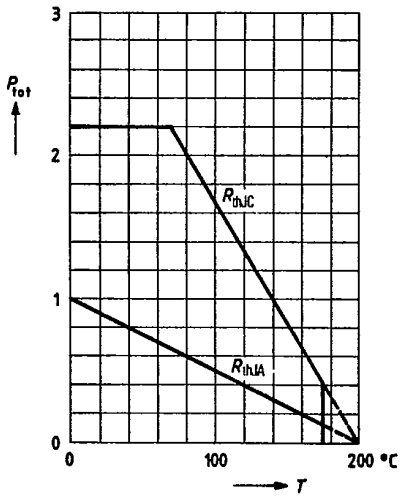

SIEMENS AKTIENGESELLSCHAFT

S parameter

Operating point: $V_{CE} = 15 \text{ V}$, $I_C = 50 \text{ mA}$, $Z_o = 50 \Omega$

f (MHz)	S ₁₁	φ	S ₂₁	φ	S ₁₂	φ	S ₂₂	φ
0,1	0,470	-172	6,25	85	0,042	77	0,455	-13
0,2	0,505	176	3,18	73	0,078	84	0,444	-17
0,3	0,540	171	2,13	65	0,114	90	0,447	-24
0,4	0,577	165	1,66	56	0,158	94	0,452	-33
0,5	0,604	161	1,36	51	0,209	97	0,451	-45
0,6	0,634	157	1,12	47	0,272	98	0,464	-58
0,7	0,637	153	0,95	44	0,332	97	0,478	-70
0,8	0,644	148	0,84	43	0,398	95	0,498	-82
0,9	0,650	143	0,76	45	0,471	93	0,526	-92
1,0	0,639	139	0,69	46	0,532	90	0,535	-99
1,1	0,620	134	0,65	49	0,586	87	0,524	-106
1,2	0,599	128	0,64	51	0,630	83	0,526	-113
1,3	0,574	121	0,64	53	0,673	79	0,505	-117
1,4	0,559	116	0,65	54	0,705	76	0,480	-121
1,5	0,549	110	0,65	54	0,722	72	0,442	-129
1,6	0,557	105	0,66	54	0,741	68	0,439	-137
1,7	0,580	104	0,67	54	0,761	66	0,439	-144
1,8	0,585	105	0,66	53	0,742	63	0,453	-156
1,9	0,593	102	0,65	51	0,723	59	0,473	-165
2,0	0,647	103	0,64	50	0,706	56	0,505	-174

SIEMENS AKTIENGESELLSCHAFT

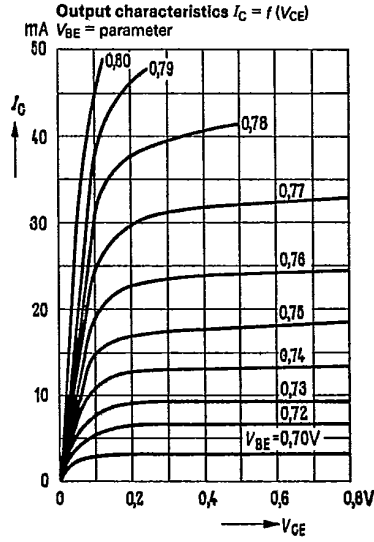
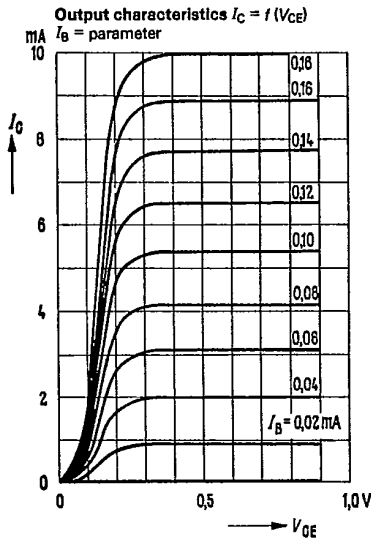
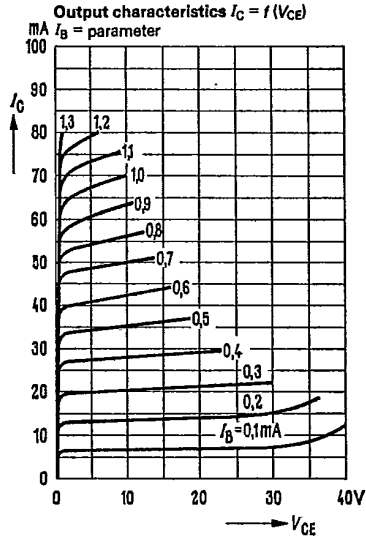
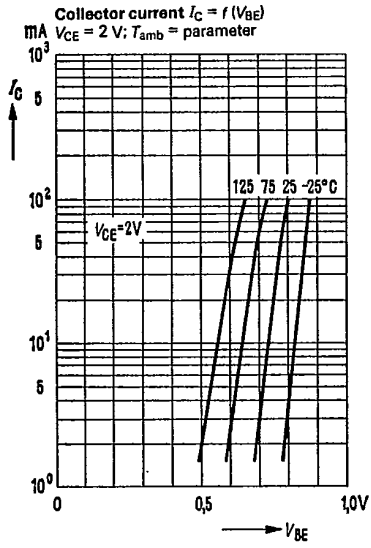

SIEMENS AKTIENGESELLSCHAFT

Collector-emitter saturation voltage

$V_{CE sat} = f(I_C)$

Base-emitter saturation voltage

$V_{BE sat} = f(I_C); h_{FE} = 20$

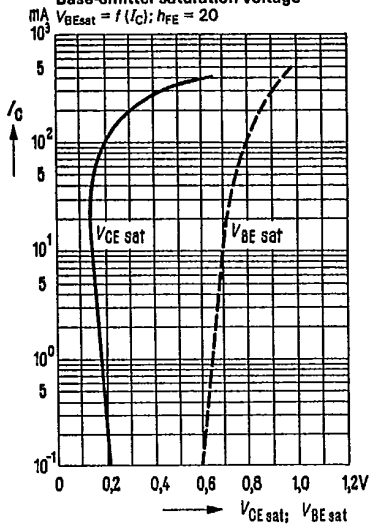

Collector cutoff current versus temperature

$I_{CBO} = f(T_{amb})$

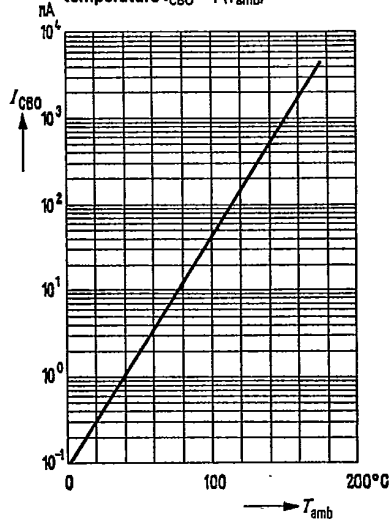

Transition frequency $f_T = f(I_C)$

$V_{CE} = \text{parameter}$

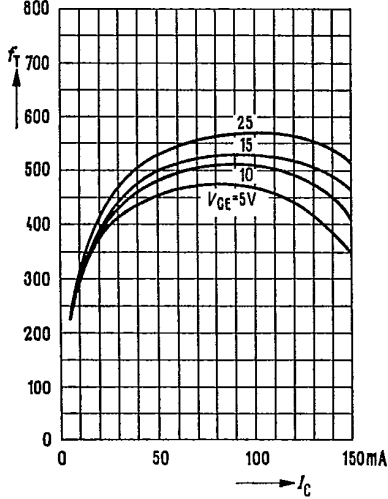

Reverse transfer capacitance

$C_{12e} = f(V_{CB})$

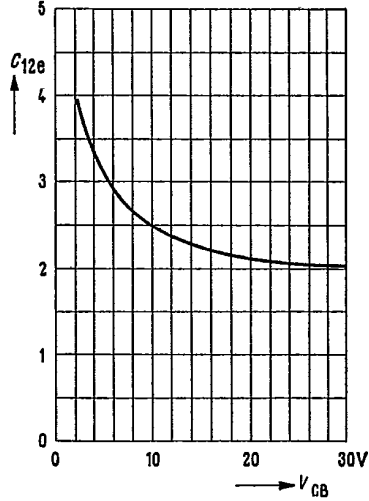



LittleDiode supplies new, hard to find or obsolete electronic components and semiconductors all over the world.

With over two million different components listed you are sure to find the part you need.

Feel free to visit us today at our online store:

LittleDiode.com

Looking forward to providing you with the best possible service.