

DATA SHEET

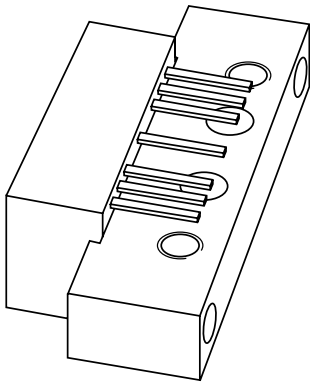

BGD702

**750 MHz, 18.5 dB gain
power doubler amplifier**

Product specification
Supersedes data of 2001 Nov 02

2001 Nov 27

750 MHz, 18.5 dB gain power doubler amplifier

BGD702

FEATURES

- Excellent linearity
- Extremely low noise
- Silicon nitride passivation
- Rugged construction
- Gold metallization ensures excellent reliability.

APPLICATIONS

- CATV systems operating in the 40 to 750 MHz frequency range.

DESCRIPTION

Hybrid amplifier module in a SOT115J package operating at a supply voltage of 24 V (DC).

PINNING - SOT115J

PIN	DESCRIPTION
1	input
2, 3	common
5	+V _B
7, 8	common
9	output

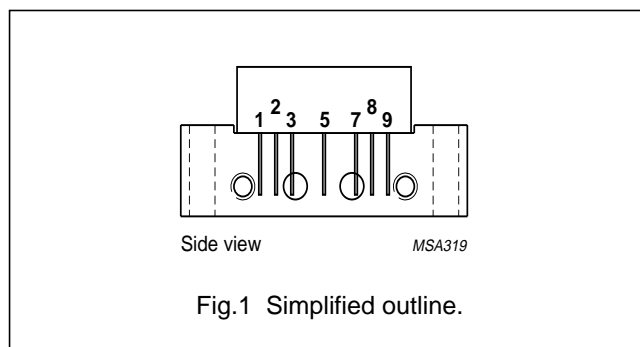

QUICK REFERENCE DATA

SYMBOL	PARAMETER	CONDITIONS	MIN.	MAX.	UNIT
G _p	power gain	f = 50 MHz	18	19	dB
		f = 750 MHz	18.5	–	dB
I _{tot}	total current consumption (DC)	V _B = 24 V	–	435	mA

LIMITING VALUES

In accordance with the Absolute Maximum Rating System (IEC 60134).

SYMBOL	PARAMETER	MIN.	MAX.	UNIT
V _i	RF input voltage	–	65	dBmV
T _{stg}	storage temperature	–40	+100	°C
T _{mb}	operating mounting base temperature	–20	+100	°C

750 MHz, 18.5 dB gain power doubler amplifier

BGD702

CHARACTERISTICS

Table 1 Bandwidth 40 to 750 MHz; $V_B = 24$ V; $T_{mb} = 35$ °C; $Z_S = Z_L = 75$ Ω

SYMBOL	PARAMETER	CONDITIONS	MIN.	TYP.	MAX.	UNIT
G_p	power gain	f = 50 MHz	18	18.5	19	dB
		f = 750 MHz	18.5	19.7	–	dB
SL	slope cable equivalent	f = 40 to 750 MHz	0.2	1.3	2	dB
FL	flatness of frequency response	f = 40 to 750 MHz	–	± 0.2	± 0.5	dB
S_{11}	input return losses	f = 40 to 80 MHz	20	27	–	dB
		f = 80 to 160 MHz	19	30	–	dB
		f = 160 to 320 MHz	18	29	–	dB
		f = 320 to 640 MHz	17	22	–	dB
		f = 640 to 750 MHz	16	21	–	dB
S_{22}	output return losses	f = 40 to 80 MHz	20	23	–	dB
		f = 80 to 160 MHz	19	24	–	dB
		f = 160 to 320 MHz	18	23	–	dB
		f = 320 to 640 MHz	17	21	–	dB
		f = 640 to 750 MHz	16	21	–	dB
S_{21}	phase response	f = 50 MHz	–45	–	+45	deg
CTB	composite triple beat	110 channels flat; $V_o = 44$ dBmV; measured at 745.25 MHz	–	–59	–58	dB
X_{mod}	cross modulation	110 channels flat; $V_o = 44$ dBmV; measured at 55.25 MHz	–	–64	–62	dB
CSO	composite second order distortion	110 channels flat; $V_o = 44$ dBmV; measured at 746.5 MHz	–	–63	–58	dB
d_2	second order distortion	note 1	–	–78	–68	dB
V_o	output voltage	$d_{im} = -60$ dB; note 2	61	64	–	dBmV
NF	noise figure	f = 50 MHz	–	4.5	5.5	dB
		f = 450 MHz	–	–	6.5	dB
		f = 550 MHz	–	–	6.5	dB
		f = 600 MHz	–	–	7	dB
		f = 750 MHz	–	6.5	8.5	dB
I_{tot}	total current consumption (DC)	note 3	–	425	435	mA

Notes

- $f_p = 55.25$ MHz; $V_p = 44$ dBmV;
 $f_q = 691.25$ MHz; $V_q = 44$ dBmV;
measured at $f_p + f_q = 746.5$ MHz.
- Measured according to DIN45004B:
 $f_p = 740.25$ MHz; $V_p = V_o$;
 $f_q = 747.25$ MHz; $V_q = V_o - 6$ dB;
 $f_r = 749.25$ MHz; $V_r = V_o - 6$ dB;
measured at $f_p + f_q - f_r = 738.25$ MHz.
- The modules normally operate at $V_B = 24$ V, but are able to withstand supply transients up to $V_B = 30$ V.

750 MHz, 18.5 dB gain power doubler amplifier

BGD702

Table 2 Bandwidth 40 to 600 MHz; $V_B = 24$ V; $T_{mb} = 35$ °C; $Z_S = Z_L = 75$ Ω

SYMBOL	PARAMETER	CONDITIONS	MIN.	TYP.	MAX.	UNIT
G _p	power gain	f = 50 MHz	18	18.5	19	dB
		f = 600 MHz	18.5	19.4	–	dB
SL	slope cable equivalent	f = 40 to 600 MHz	0.2	–	2	dB
FL	flatness of frequency response	f = 40 to 600 MHz	–	–	±0.3	dB
S ₁₁	input return losses	f = 40 to 80 MHz	20	27	–	dB
		f = 80 to 160 MHz	19	30	–	dB
		f = 160 to 320 MHz	18	29	–	dB
		f = 320 to 600 MHz	17	22	–	dB
S ₂₂	output return losses	f = 40 to 80 MHz	20	23	–	dB
		f = 80 to 160 MHz	19	24	–	dB
		f = 160 to 320 MHz	18	23	–	dB
		f = 320 to 600 MHz	17	21	–	dB
S ₂₁	phase response	f = 50 MHz	–45	–	+45	deg
CTB	composite triple beat	85 channels flat; V _o = 44 dBmV; measured at 595.25 MHz	–	–66	–65	dB
X _{mod}	cross modulation	85 channels flat; V _o = 44 dBmV; measured at 55.25 MHz	–	–66	–65	dB
CSO	composite second order distortion	85 channels flat; V _o = 44 dBmV; measured at 596.5 MHz	–	–68	–60	dB
d ₂	second order distortion	note 1	–	–80	–70	dB
V _o	output voltage	d _{im} = –60 dB; note 2	64	67	–	dBmV
NF	noise figure	see Table 1	–	–	–	dB
I _{tot}	total current consumption (DC)	note 3	–	425	435	mA

Notes

1. $f_p = 55.25$ MHz; $V_p = 44$ dBmV;
 $f_q = 541.25$ MHz; $V_q = 44$ dBmV;
measured at $f_p + f_q = 596.5$ MHz.
2. Measured according to DIN45004B:
 $f_p = 590.25$ MHz; $V_p = V_o$;
 $f_q = 597.25$ MHz; $V_q = V_o - 6$ dB;
 $f_r = 599.25$ MHz; $V_r = V_o - 6$ dB;
measured at $f_p + f_q - f_r = 588.25$ MHz.
3. The modules normally operate at $V_B = 24$ V, but are able to withstand supply transients up to $V_B = 30$ V.

750 MHz, 18.5 dB gain power doubler amplifier

BGD702

Table 3 Bandwidth 40 to 550 MHz; $V_B = 24$ V; $T_{mb} = 35$ °C; $Z_S = Z_L = 75$ Ω

SYMBOL	PARAMETER	CONDITIONS	MIN.	TYP.	MAX.	UNIT
G _p	power gain	f = 50 MHz	18	18.5	19	dB
		f = 550 MHz	18.5	19.3	–	dB
SL	slope cable equivalent	f = 40 to 550 MHz	0.2	–	2	dB
FL	flatness of frequency response	f = 40 to 550 MHz	–	–	±0.3	dB
S ₁₁	input return losses	f = 40 to 80 MHz	20	27	–	dB
		f = 80 to 160 MHz	19	30	–	dB
		f = 160 to 320 MHz	18	29	–	dB
		f = 320 to 550 MHz	17	22	–	dB
S ₂₂	output return losses	f = 40 to 80 MHz	20	23	–	dB
		f = 80 to 160 MHz	19	24	–	dB
		f = 160 to 320 MHz	18	23	–	dB
		f = 320 to 550 MHz	17	21	–	dB
S ₂₁	phase response	f = 50 MHz	–45	–	+45	deg
CTB	composite triple beat	77 channels flat; V _o = 44 dBmV; measured at 547.25 MHz	–	–68	–67	dB
X _{mod}	cross modulation	77 channels flat; V _o = 44 dBmV; measured at 55.25 MHz	–	–68	–67	dB
CSO	composite second order distortion	77 channels flat; V _o = 44 dBmV; measured at 548.5 MHz	–	–68	–62	dB
d ₂	second order distortion	note 1	–	–81	–72	dB
V _o	output voltage	d _{im} = –60 dB; note 2	64.5	68	–	dBmV
NF	noise figure	see Table 1	–	–	–	dB
I _{tot}	total current consumption (DC)	note 3	–	425	435	mA

Notes

1. $f_p = 55.25$ MHz; $V_p = 44$ dBmV;
 $f_q = 493.25$ MHz; $V_q = 44$ dBmV;
measured at $f_p + f_q = 548.5$ MHz.
2. Measured according to DIN45004B:
 $f_p = 540.25$ MHz; $V_p = V_o$;
 $f_q = 547.25$ MHz; $V_q = V_o - 6$ dB;
 $f_r = 549.25$ MHz; $V_r = V_o - 6$ dB;
measured at $f_p + f_q - f_r = 538.25$ MHz.
3. The modules normally operate at $V_B = 24$ V, but are able to withstand supply transients up to $V_B = 30$ V.

750 MHz, 18.5 dB gain power doubler amplifier

BGD702

Table 4 Bandwidth 40 to 450 MHz; $V_B = 24$ V; $T_{mb} = 35$ °C; $Z_S = Z_L = 75$ Ω

SYMBOL	PARAMETER	CONDITIONS	MIN.	TYP.	MAX.	UNIT
G _p	power gain	f = 50 MHz	18	18.5	19	dB
		f = 450 MHz	18.5	19.2	–	dB
SL	slope cable equivalent	f = 40 to 450 MHz	0.2	–	2	dB
FL	flatness of frequency response	f = 40 to 450 MHz	–	–	±0.3	dB
S ₁₁	input return losses	f = 40 to 80 MHz	20	27	–	dB
		f = 80 to 160 MHz	19	30	–	dB
		f = 160 to 320 MHz	18	29	–	dB
		f = 320 to 450 MHz	17	22	–	dB
S ₂₂	output return losses	f = 40 to 80 MHz	20	23	–	dB
		f = 80 to 160 MHz	19	24	–	dB
		f = 160 to 320 MHz	18	23	–	dB
		f = 320 to 450 MHz	17	21	–	dB
S ₂₁	phase response	f = 50 MHz	–45	–	+45	deg
CTB	composite triple beat	60 channels flat; V _o = 46 dBmV; measured at 445.25 MHz	–	–	–68	dB
X _{mod}	cross modulation	60 channels flat; V _o = 46 dBmV; measured at 55.25 MHz	–	–	–65	dB
CSO	composite second order distortion	60 channels flat; V _o = 46 dBmV measured at 446.5 MHz	–	–	–65	dB
d ₂	second order distortion	note 1	–	–	–75	dB
V _o	output voltage	d _{im} = –60 dB; note 2	67	–	–	dBmV
NF	noise figure	see Table 1	–	–	–	dB
I _{tot}	total current consumption (DC)	note 3	–	425	435	mA

Notes

- f_p = 55.25 MHz; V_p = 46 dBmV;
f_q = 391.25 MHz; V_q = 46 dBmV;
measured at f_p + f_q = 446.5 MHz.
- Measured according to DIN45004B:
f_p = 440.25 MHz; V_p = V_o;
f_q = 447.25 MHz; V_q = V_o –6 dB;
f_r = 449.25 MHz; V_r = V_o –6 dB;
measured at f_p + f_q – f_r = 438.25 MHz.
- The modules normally operate at V_B = 24 V, but are able to withstand supply transients up to V_B = 30 V.

750 MHz, 18.5 dB gain power doubler amplifier

BGD702

PACKAGE OUTLINE

Rectangular single-ended package; aluminium flange; 2 vertical mounting holes; 2 x 6-32 UNC and 2 extra horizontal mounting holes; 7 gold-plated in-line leads

SOT115J

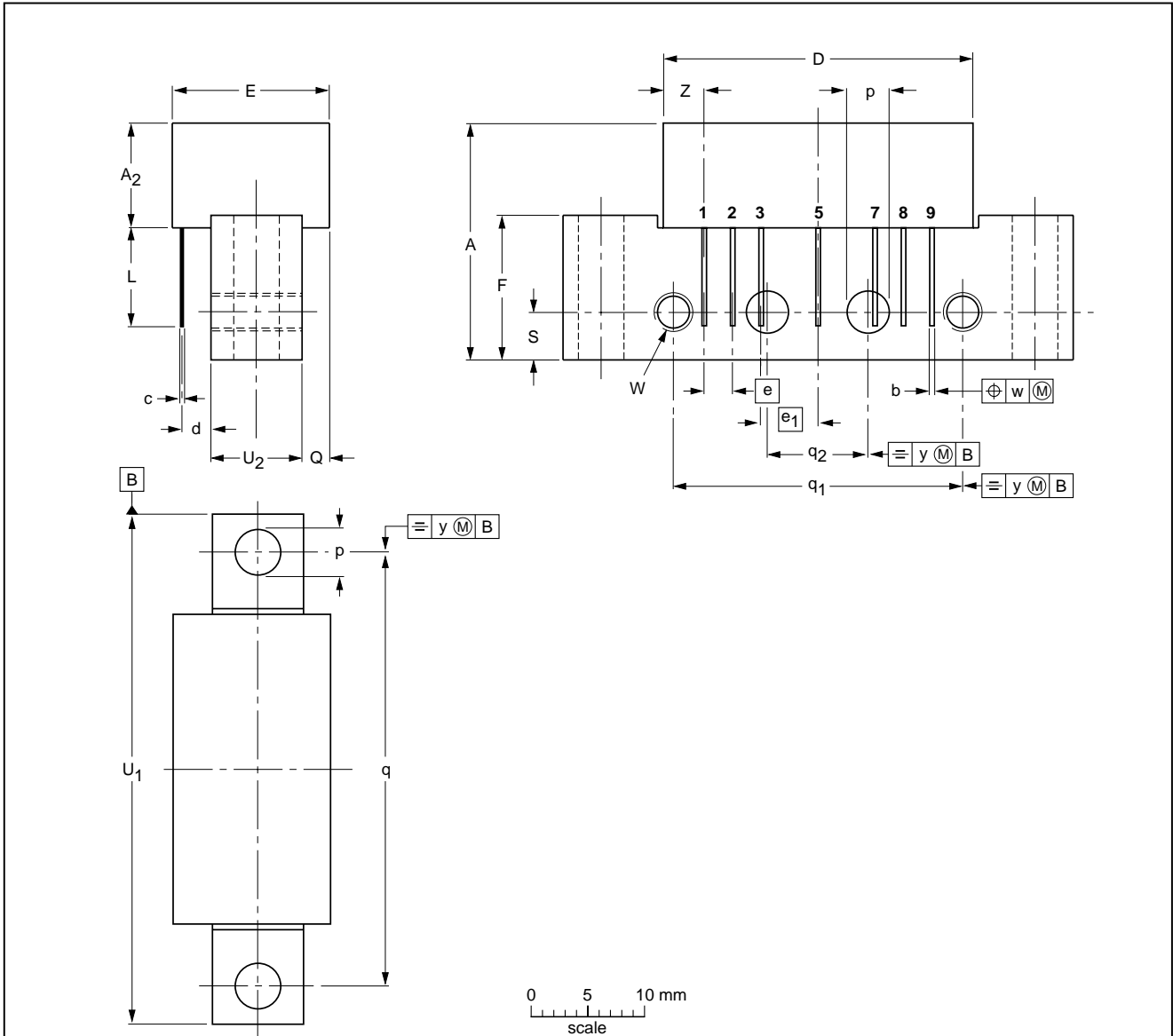

DIMENSIONS (mm are the original dimensions)

UNIT	A max.	A2 max.	b	c	D max.	d max.	E max.	e	e1	F	L min.	p	Q max.	q	q1	q2	S	U1 max.	U2	W	w	y	Z max.
mm	20.8	9.1	0.51 0.38	0.25	27.2	2.54	13.75	2.54	5.08	12.7	8.8	4.15 3.85	2.4	38.1	25.4	10.2	4.2	44.75	8	6-32 UNC	0.25	0.1	3.8

OUTLINE VERSION	REFERENCES				EUROPEAN PROJECTION	ISSUE DATE
	IEC	JEDEC	EIAJ			
SOT115J						99-02-06

750 MHz, 18.5 dB gain power doubler amplifier

BGD702

DATA SHEET STATUS

DATA SHEET STATUS ⁽¹⁾	PRODUCT STATUS ⁽²⁾	DEFINITIONS
Objective data	Development	This data sheet contains data from the objective specification for product development. Philips Semiconductors reserves the right to change the specification in any manner without notice.
Preliminary data	Qualification	This data sheet contains data from the preliminary specification. Supplementary data will be published at a later date. Philips Semiconductors reserves the right to change the specification without notice, in order to improve the design and supply the best possible product.
Product data	Production	This data sheet contains data from the product specification. Philips Semiconductors reserves the right to make changes at any time in order to improve the design, manufacturing and supply. Changes will be communicated according to the Customer Product/Process Change Notification (CPCN) procedure SNW-SQ-650A.

Notes

1. Please consult the most recently issued data sheet before initiating or completing a design.
2. The product status of the device(s) described in this data sheet may have changed since this data sheet was published. The latest information is available on the Internet at URL <http://www.semiconductors.philips.com>.

DEFINITIONS

Short-form specification — The data in a short-form specification is extracted from a full data sheet with the same type number and title. For detailed information see the relevant data sheet or data handbook.

Limiting values definition — Limiting values given are in accordance with the Absolute Maximum Rating System (IEC 60134). Stress above one or more of the limiting values may cause permanent damage to the device. These are stress ratings only and operation of the device at these or at any other conditions above those given in the Characteristics sections of the specification is not implied. Exposure to limiting values for extended periods may affect device reliability.

Application information — Applications that are described herein for any of these products are for illustrative purposes only. Philips Semiconductors make no representation or warranty that such applications will be suitable for the specified use without further testing or modification.

DISCLAIMERS

Life support applications — These products are not designed for use in life support appliances, devices, or systems where malfunction of these products can reasonably be expected to result in personal injury. Philips Semiconductors customers using or selling these products for use in such applications do so at their own risk and agree to fully indemnify Philips Semiconductors for any damages resulting from such application.

Right to make changes — Philips Semiconductors reserves the right to make changes, without notice, in the products, including circuits, standard cells, and/or software, described or contained herein in order to improve design and/or performance. Philips Semiconductors assumes no responsibility or liability for the use of any of these products, conveys no licence or title under any patent, copyright, or mask work right to these products, and makes no representations or warranties that these products are free from patent, copyright, or mask work right infringement, unless otherwise specified.

CAUTION

This product is supplied in anti-static packing to prevent damage caused by electrostatic discharge during transport and handling. For further information, refer to Philips specs.: SNW-EQ-608, SNW-FQ-302A and SNW-FQ-302B.

750 MHz, 18.5 dB gain power doubler amplifier

BGD702

NOTES

750 MHz, 18.5 dB gain power doubler amplifier

BGD702

NOTES

750 MHz, 18.5 dB gain power doubler amplifier

BGD702

NOTES

Philips Semiconductors – a worldwide company

Contact information

For additional information please visit <http://www.semiconductors.philips.com>. Fax: +31 40 27 24825

For sales offices addresses send e-mail to: sales.addresses@www.semiconductors.philips.com.

© Koninklijke Philips Electronics N.V. 2001

SCA73

All rights are reserved. Reproduction in whole or in part is prohibited without the prior written consent of the copyright owner.

The information presented in this document does not form part of any quotation or contract, is believed to be accurate and reliable and may be changed without notice. No liability will be accepted by the publisher for any consequence of its use. Publication thereof does not convey nor imply any license under patent- or other industrial or intellectual property rights.

Printed in The Netherlands

613518/07/pp12

Date of release: 2001 Nov 27

Document order number: 9397 750 09068

Let's make things better.

**Philips
Semiconductors**



PHILIPS



LittleDiode supplies new, hard to find or obsolete electronic components and semiconductors all over the world.

With over two million different components listed you are sure to find the part you need.

Feel free to visit us today at our online store:

LittleDiode.com

Looking forward to providing you with the best possible service.