

DATA SHEET

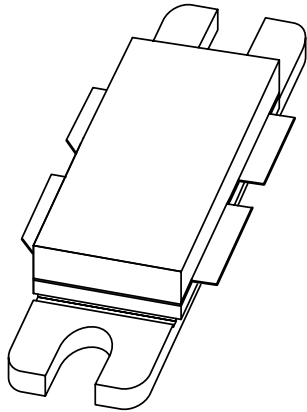

BLF647 UHF power LDMOS transistor

Product specification
Supersedes data of 2001 Aug 02

2001 Nov 27

UHF power LDMOS transistor

BLF647

FEATURES

- High power gain
- Easy power control
- Excellent ruggedness
- Source on underside eliminates DC isolators, reducing common mode inductance
- Designed for broadband operation (HF to 800 MHz)
- Internal input damping for excellent stability over the whole frequency range.

APPLICATIONS

- Communication transmitter applications in the HF to 800 MHz frequency range.

DESCRIPTION

Silicon N-channel enhancement mode lateral D-MOS push-pull transistor in a SOT540A package with ceramic cap. The common source is connected to the mounting flange.

PINNING - SOT540A

PIN	DESCRIPTION
1	drain 1
2	drain 2
3	gate 1
4	gate 2
5	source, connected to flange

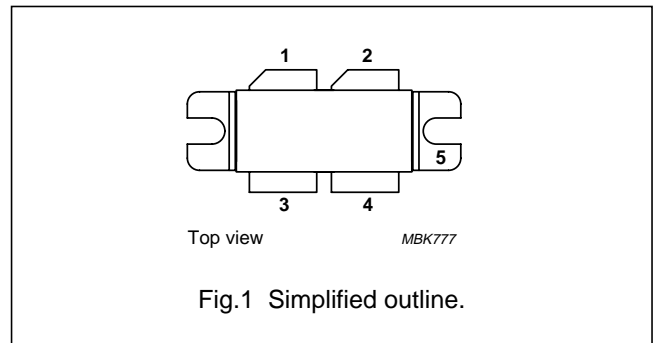

QUICK REFERENCE DATA

RF performance at $T_h = 25\text{ °C}$ in a common source test circuit.

MODE OF OPERATION	f (MHz)	V_{DS} (V)	P_L (W)	G_p (dB)	η_D (%)	d_{im} (dBc)
CW, class-AB	600	28	120	>14.5	>55	–
2-tone, class-AB	$f_1 = 600; f_2 = 600.1$	28	120 (PEP)	>14.5	>40	≤ -26

LIMITING VALUES

In accordance with the Absolute Maximum Rating System (IEC 60134).

SYMBOL	PARAMETER	CONDITIONS	MIN.	MAX.	UNIT
V_{DS}	drain-source voltage		–	65	V
V_{GS}	gate-source voltage		–	± 15	V
I_D	drain current (DC)		–	18	A
P_{tot}	total power dissipation	$T_{mb} \leq 25\text{ °C}$	–	290	W
T_{stg}	storage temperature		–65	+150	°C
T_j	junction temperature		–	200	°C

CAUTION

This product is supplied in anti-static packing to prevent damage caused by electrostatic discharge during transport and handling. For further information, refer to Philips specs.: SNW-EQ-608, SNW-FQ-302A and SNW-FQ-302B.

UHF power LDMOS transistor

BLF647

THERMAL CHARACTERISTICS

SYMBOL	PARAMETER	CONDITIONS	VALUE	UNIT
$R_{th\ j-mb}$	thermal resistance from junction to mounting base	$T_{mb} = 25\ ^\circ\text{C}; P_{tot} = 290\ \text{W}$	0.6	K/W
$R_{th\ mb-h}$	thermal resistance from mounting base to heatsink		0.2	K/W

CHARACTERISTICS

$T_j = 25\ ^\circ\text{C}$ per section unless otherwise specified.

SYMBOL	PARAMETER	CONDITIONS	MIN.	TYP.	MAX.	UNIT
$V_{(BR)DSS}$	drain-source breakdown voltage	$V_{GS} = 0; I_D = 1.4\ \text{mA}$	65	–	–	V
V_{GSth}	gate-source threshold voltage	$V_{DS} = 20\ \text{V}; I_D = 140\ \text{mA}$	4	–	5.5	V
I_{DSS}	drain-source leakage current	$V_{GS} = 0; V_{DS} = 28\ \text{V}$	–	–	1.2	μA
I_{DSX}	drain cut-off current	$V_{GS} = V_{GSth} + 9\ \text{V}; V_{DS} = 10\ \text{V}$	18	–	–	A
I_{GSS}	gate leakage current	$V_{GS} = \pm 15\ \text{V}; V_{DS} = 0$	–	–	25	nA
g_{fs}	forward transconductance	$V_{DS} = 20\ \text{V}; I_D = 4\ \text{A}$	–	4	–	S
R_{DSon}	drain-source on-state resistance	$V_{GS} = V_{GSth} + 9\ \text{V}; I_D = 4\ \text{A}$	–	160	–	$\text{m}\Omega$
C_{iss}	input capacitance	$V_{GS} = 0; V_{DS} = 28\ \text{V}; f = 1\ \text{MHz};$ note 1	–	80	–	pF
C_{oss}	output capacitance	$V_{GS} = 0; V_{DS} = 28\ \text{V}; f = 1\ \text{MHz}$	–	43	–	pF
C_{rss}	feedback capacitance	$V_{GS} = 0; V_{DS} = 28\ \text{V}; f = 1\ \text{MHz}$	–	6	–	pF

Note

1. Capacitance values of the die only.

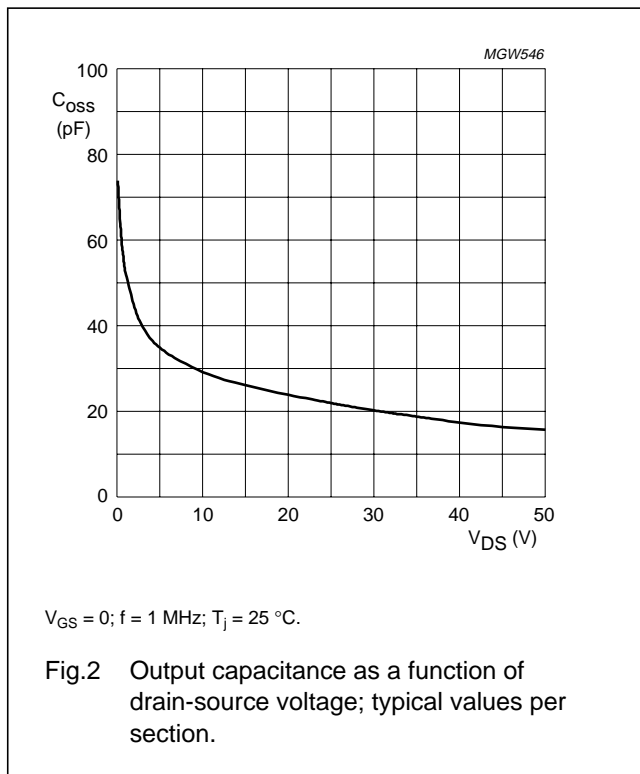

UHF power LDMOS transistor

BLF647

APPLICATION INFORMATION

RF performance in a common source class-AB circuit. $T_h = 25\text{ °C}$; $R_{th\ mb-h} = 0.2\text{ K/W}$, unless otherwise specified.

MODE OF OPERATION	f (MHz)	V _{DS} (V)	P _L (W)	G _p (dB)	η _D (%)	d _{im} (dBc)
CW, class-AB	600	28	120	>14.5	>55	–
2-tone, class-AB	f ₁ = 600; f ₂ = 600.1	28	120 (PEP)	>14.5	>40	≤–26
CW, class-AB	800	32	150	typ. 12.5	typ. 60	–
2-tone, class-AB	f ₁ = 800; f ₂ = 800.1	32	150 (PEP)	typ. 13	typ. 45	typ. –30

Ruggedness in class-AB operation

The BLF647 is capable of withstanding a load mismatch corresponding to VSWR = 10 : 1 through all phases under the following conditions: V_{DS} = 28 V; f = 100 MHz at rated load power.

The BLF647 is capable of withstanding abrupt source or load mismatch errors under the nominal power conditions.

Impedances (per section)

At f = 600 MHz, P_L = 120 W, V_{DS} = 28 V and I_{DQ} = 1 A: Z_{in} = 1.0 + j2.0 Ω and Z_L = 2.7 + j0.7 Ω.

At f = 800 MHz, P_L = 150 W, V_{DS} = 32 V and I_{DQ} = 1 A: Z_{in} = 1.0 + j3.8 Ω and Z_L = 1.8 + j0.7 Ω.

UHF power LDMOS transistor

BLF647

Application at 600 MHz

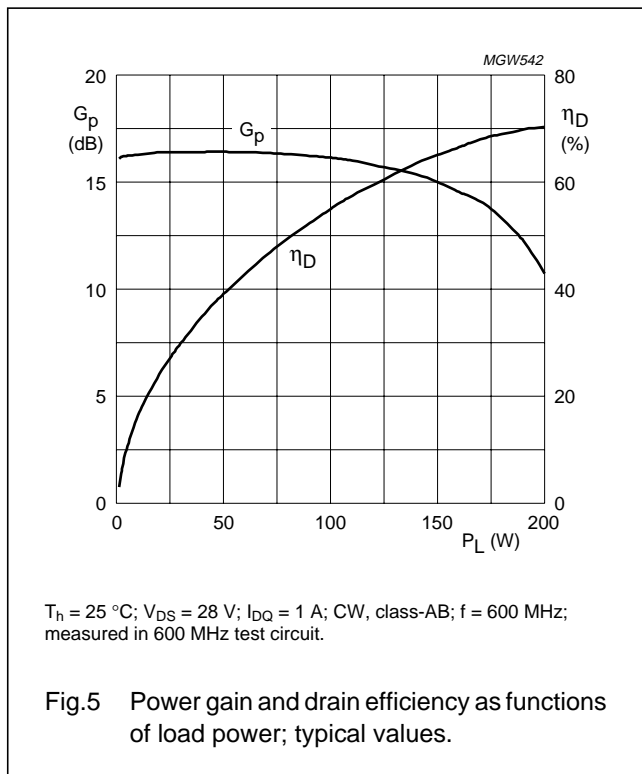
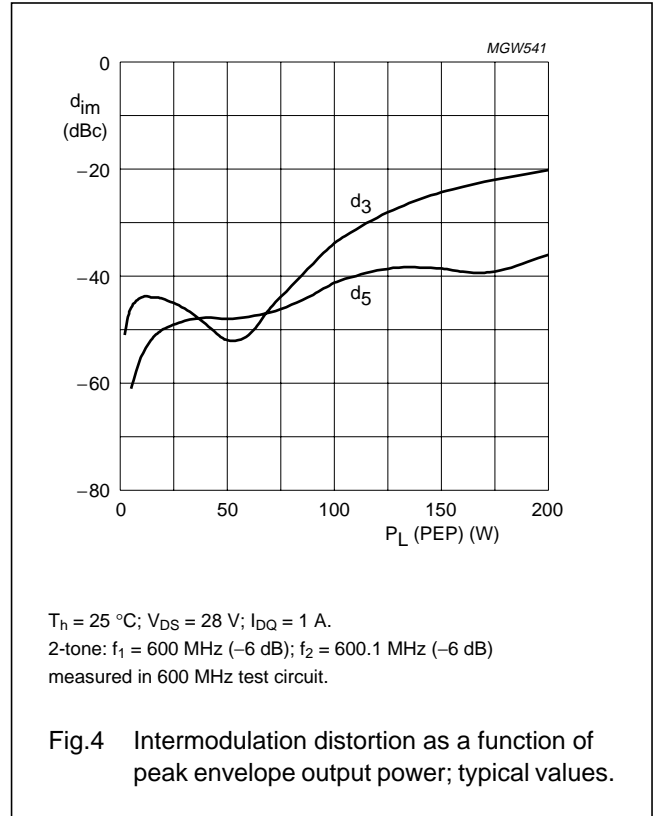
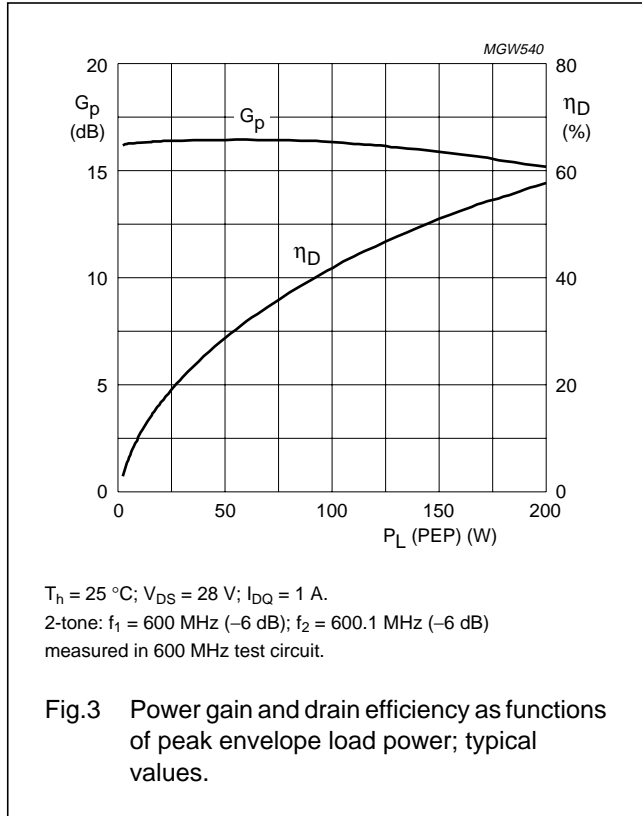

UHF power LDMOS transistor

BLF647

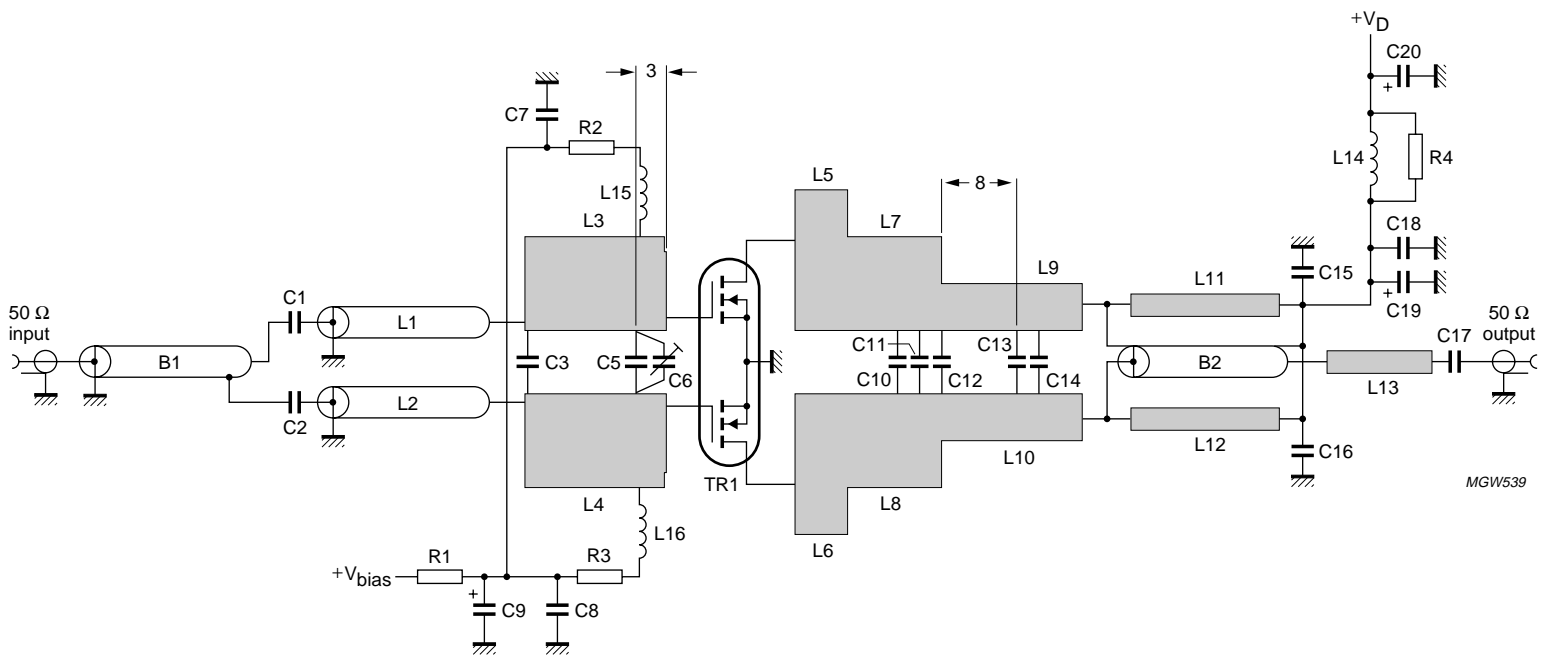

Dimensions in mm.

Fig.6 Class-AB common source 600 MHz test circuit.

UHF power LDMOS transistor

BLF647

List of components class-AB 600 MHz test circuit (see Figs 6 and 7)

COMPONENT	DESCRIPTION	VALUE	DIMENSIONS	CATALOGUE No.
C1, C2	multilayer ceramic chip capacitor; note 1	30 pF		
C3	multilayer ceramic chip capacitor; note 1	8.2 pF		
C5	multilayer ceramic chip capacitor; note 1	16 pF		
C6	Tekelec trimmer	0.6 to 7.5 pF		
C7, C8	multilayer ceramic chip capacitor; note 1	100 pF		
C9	electrolytic capacitor	10 μ F		
C10	multilayer ceramic chip capacitor; note 2	2 pF		
C11, C12	multilayer ceramic chip capacitor; note 2	10 pF		
C13	multilayer ceramic chip capacitor; note 2	8.2 pF		
C14	multilayer ceramic chip capacitor; note 2	1.5 pF		
C15, C16, C17	multilayer ceramic chip capacitor; note 2	100 pF		
C18	SMD capacitor	1 μ F		2222 595 16754
C19	electrolytic capacitor	470 μ F		
C20	electrolytic capacitor	100 μ F		
L1, L2	semi rigid coax UT70-25	$Z = 25 \Omega \pm 1.5 \Omega$	30.6 mm	
L3, L4	stripline; note 3		15 \times 10 mm	
L5, L6	stripline; note 3		5.5 \times 15 mm	
L7, L8	stripline; note 3		10 \times 10 mm	
L9, L10	stripline; note 3		15 \times 5 mm	
L11, L12	stripline; note 3		48.5 \times 2.4 mm	
L13	stripline; note 3		10 \times 2.4 mm	
L14	ferrite			
L15, L16	Coilcraft SMD coil 1008CS-102XKBC	1 μ H		
B1	semi rigid coax ($\lambda/2$)	$Z = 50 \Omega \pm 1.5 \Omega$	$\lambda/2$	
B2	semi rigid coax balun UT70-25	$Z = 25 \Omega \pm 1.5 \Omega$	48.5 mm	
R1	resistor	1 k Ω		
R2, R3	resistor	100 Ω		
R4	resistor	3,3 Ω		

Notes

1. American Technical Ceramics type 100A or capacitor of same quality.
2. American Technical Ceramics type 180R or capacitor of same quality.
3. The striplines are on a double copper-clad printed-circuit board: Rogers 5880 ($\epsilon_r = 2.2$); thickness 0.79 mm.

UHF power LDMOS transistor

BLF647

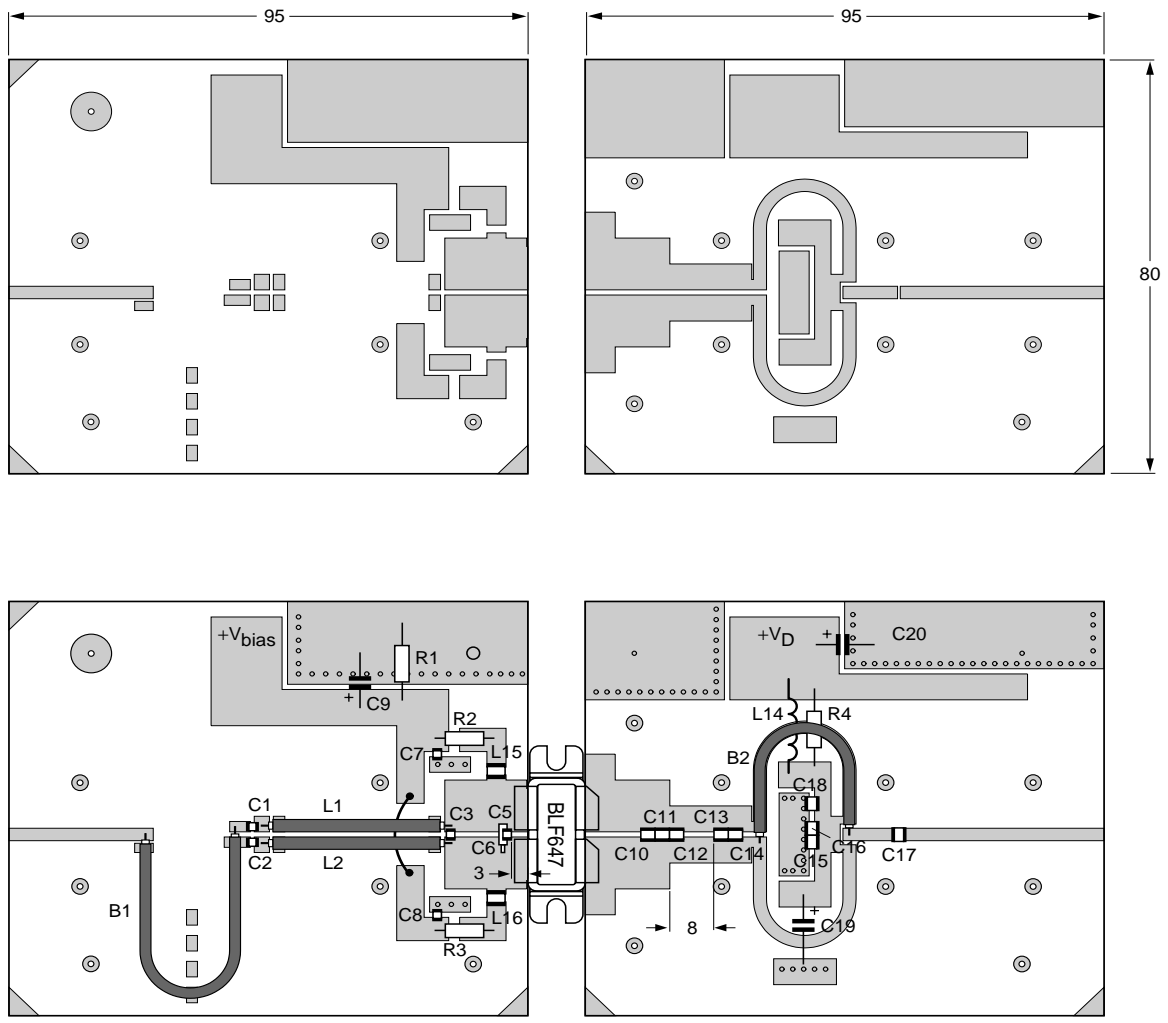

MGW547

Dimensions in mm.

The components are situated on one side of the Rogers 5880 printed-circuit board, the other side is unetched and serves as a ground plane. Earth connections from the component side to the ground plane are made by through metallization.

Fig.7 Printed-circuit board and component layout for class-AB 600 MHz test circuit.

UHF power LDMOS transistor

BLF647

Application at 800 MHz

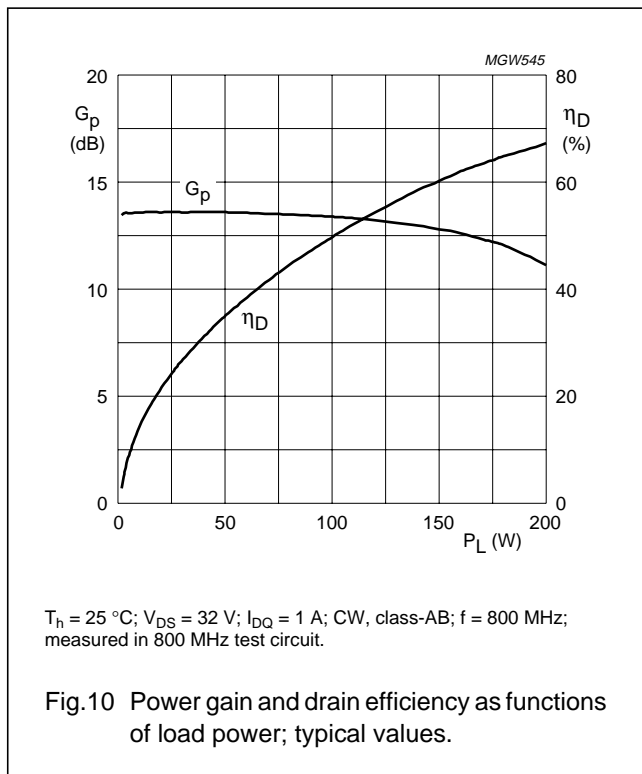
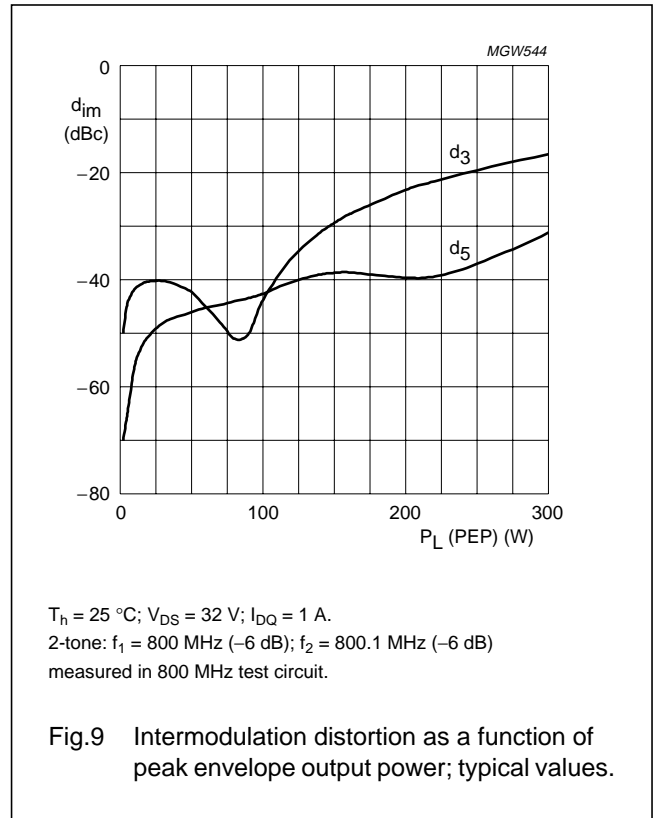
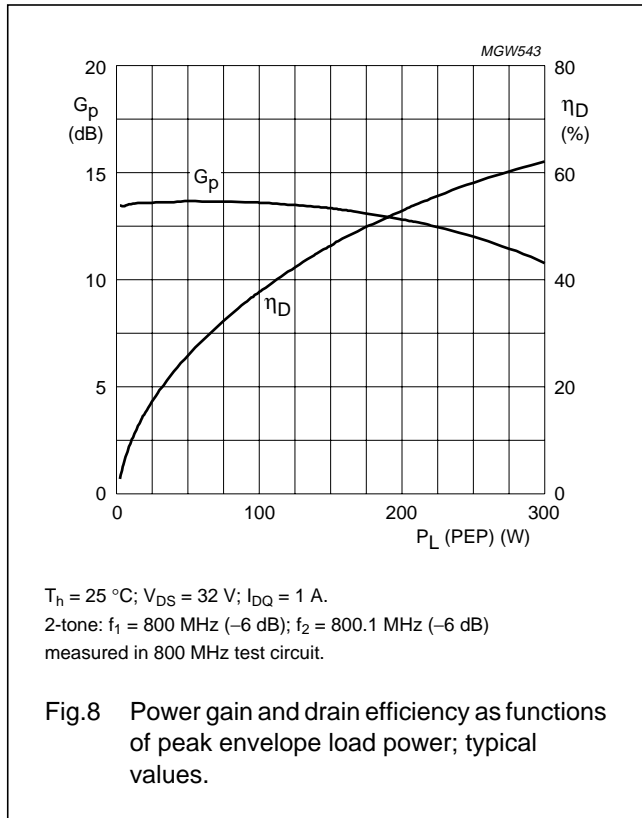

UHF power LDMOS transistor

BLF647

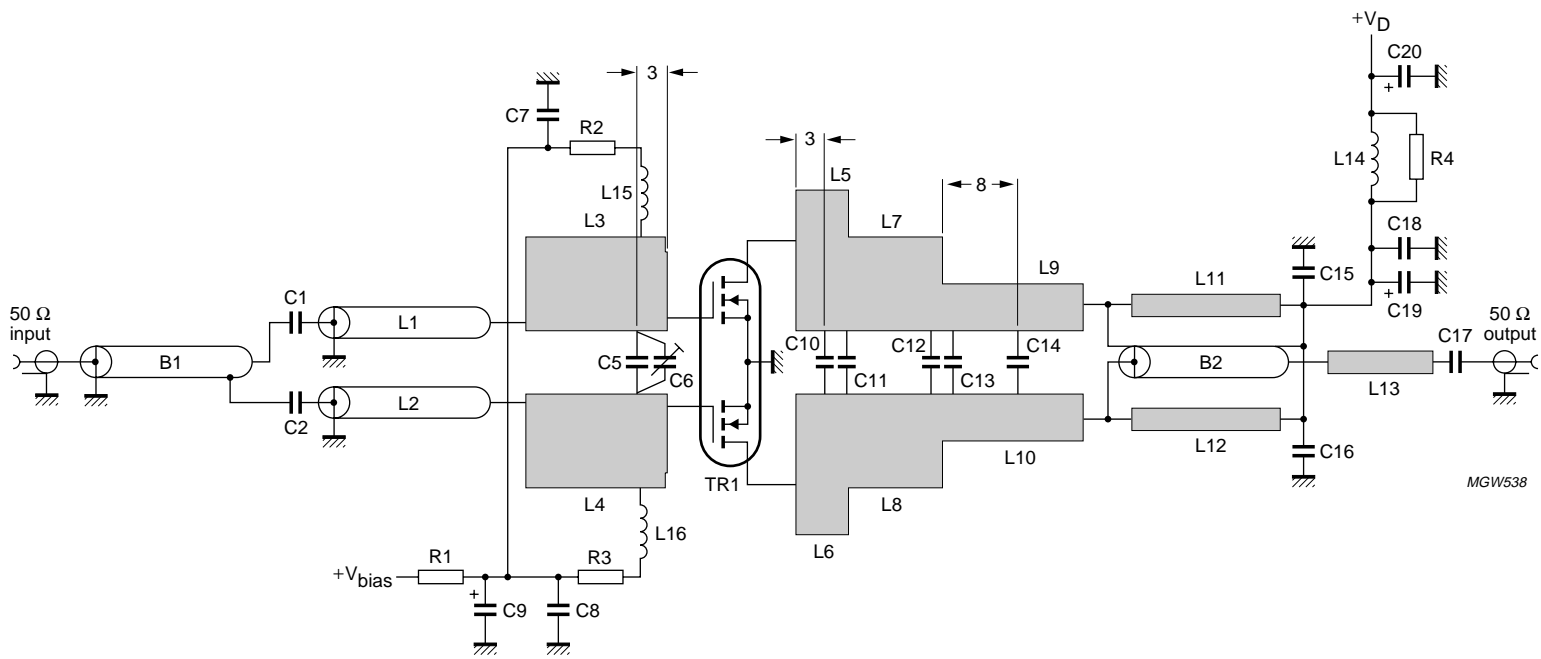

MGW538

Fig.11 Class-AB common source 800 MHz test circuit.

Dimensions in mm.

UHF power LDMOS transistor

BLF647

List of components class-AB 800 MHz test circuit (see Figs 11 and 12)

COMPONENT	DESCRIPTION	VALUE	DIMENSIONS	CATALOGUE No.
C1, C2	multilayer ceramic chip capacitor; note 1	30 pF		
C5	multilayer ceramic chip capacitor; note 1	10 pF		
C6	tekelec trimmer	0.6 to 7.5 pF		
C7, C8	multilayer ceramic chip capacitor; note 1	100 pF		
C9	electrolytic capacitor	10 μ F		
C10, C11	multilayer ceramic chip capacitor; note 2	8.2 pF		
C12, C13	multilayer ceramic chip capacitor; note 2	10 pF		
C14	multilayer ceramic chip capacitor; note 2	4.7 pF		
C15, C16	multilayer ceramic chip capacitor; note 2	100 pF		
C17	multilayer ceramic chip capacitor; note 2	20 pF		
C18	SMD capacitor	1 μ F		2222 595 16754
C19	electrolytic capacitor	470 μ F		
C20	electrolytic capacitor	100 μ F		
L1, L2	semi rigid coax UT70-25	$Z = 25 \Omega \pm 1.5 \Omega$	30.6 mm	
L3, L4	stripline; note 3		15 \times 10 mm	
L5, L6	stripline; note 3		5.5 \times 15 mm	
L7, L8	stripline; note 3		10 \times 10 mm	
L9, L10	stripline; note 3		15 \times 5 mm	
L11, L12	stripline; note 3		48.5 \times 2.4 mm	
L13	stripline; note 3		10 \times 2.4 mm	
L14	ferrite			
L15, L16	Coilcraft SMD coil 1008CS-102XKBC	1 μ H		
B1	semi rigid coax ($\lambda/2$)	$Z = 50 \Omega \pm 1.5 \Omega$	$\lambda/2$	
B2	semi rigid coax balun UT70-25	$Z = 25 \Omega \pm 1.5 \Omega$	48.5 mm	
R1	resistor	1 k Ω		
R2, R3	resistor	100 Ω		
R4	resistor	3,3 Ω		

Notes

1. American Technical Ceramics type 100A or capacitor of same quality.
2. American Technical Ceramics type 180R or capacitor of same quality.
3. The striplines are on a double copper-clad printed-circuit board: Rogers 5880 ($\epsilon_r = 2.2$); thickness 0.79 mm.

UHF power LDMOS transistor

BLF647

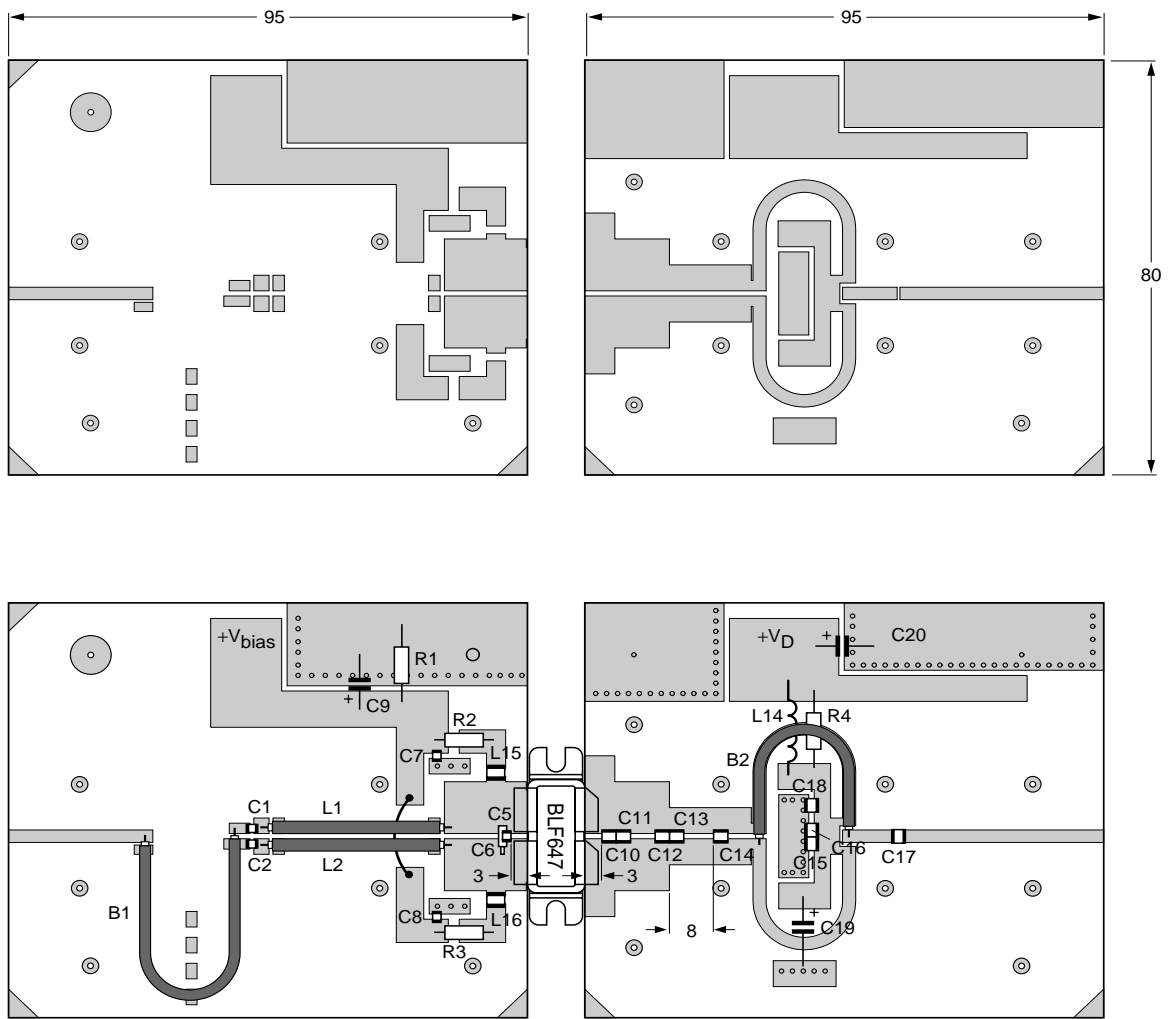

MGW548

Dimensions in mm.

The components are situated on one side of the Rogers 5880 printed-circuit board, the other side is unetched and serves as a ground plane. Earth connections from the component side to the ground plane are made by through metallization.

Fig.12 Printed-circuit board and component layout for class-AB 800 MHz test circuit.

UHF power LDMOS transistor

BLF647

PACKAGE OUTLINE

Flanged balanced LDMOST ceramic package; 2 mounting holes; 4 leads

SOT540A

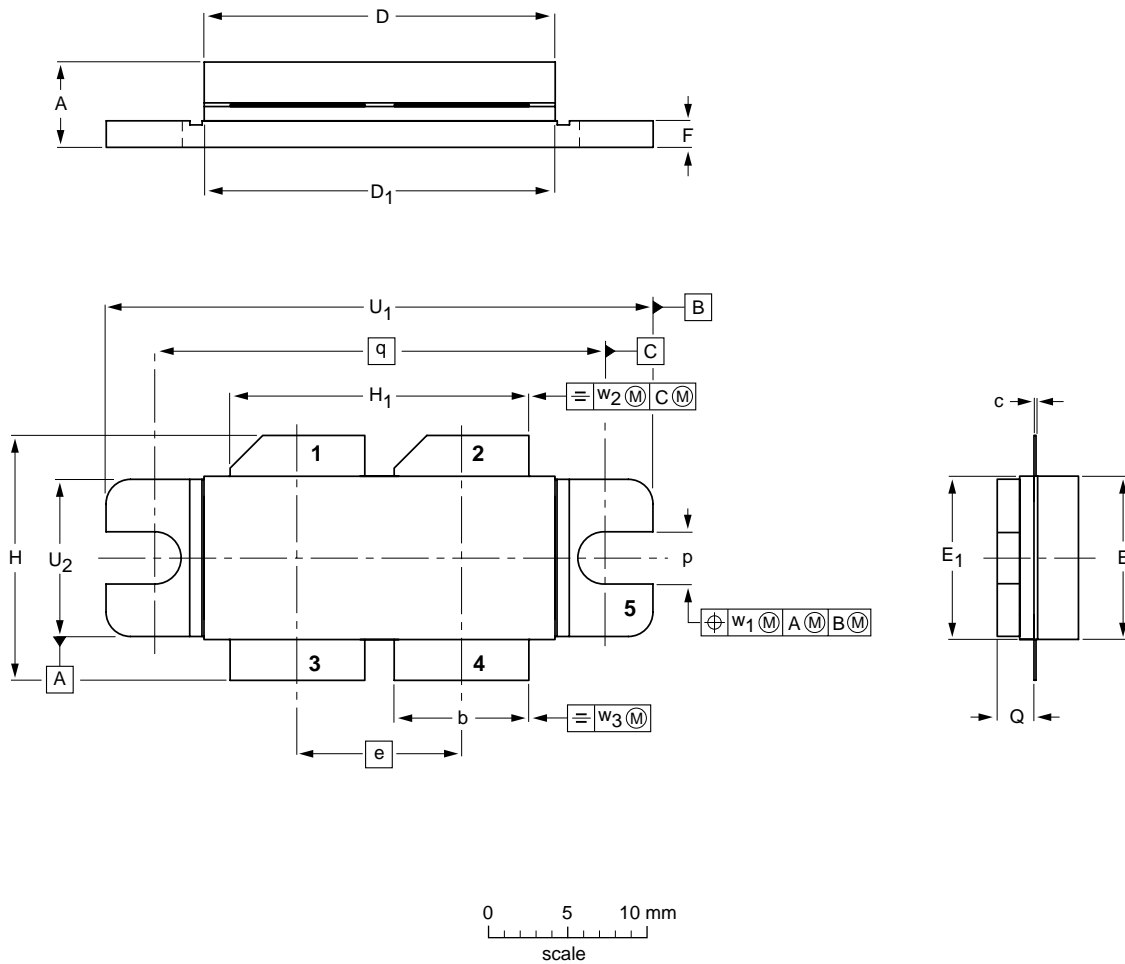

DIMENSIONS (millimetre dimensions are derived from the original inch dimensions)

UNIT	A	b	c	D	D ₁	e	E	E ₁	F	H	H ₁	p	Q	q	U ₁	U ₂	w ₁	w ₂	w ₃
mm	5.77 5.00	8.51 8.26	0.15 0.10	22.05 21.64	22.05 21.64	10.21	10.26 10.06	10.31 10.01	1.78 1.52	15.75 14.73	18.72 18.47	3.38 3.12	2.72 2.46	27.94	34.16 33.91	9.91 9.65	0.25	0.51	0.25
inches	0.227 0.197	0.335 0.325	0.006 0.004	0.868 0.852	0.868 0.852	0.402	0.404 0.396	0.406 0.394	0.070 0.060	0.620 0.580	0.737 0.727	0.133 0.123	0.107 0.097	1.100	1.345 1.335	0.390 0.380	0.010	0.020	0.010

OUTLINE VERSION	REFERENCES				EUROPEAN PROJECTION	ISSUE DATE
	IEC	JEDEC	EIAJ			
SOT540A						99-08-27 99-12-28

UHF power LDMOS transistor

BLF647

DATA SHEET STATUS

DATA SHEET STATUS ⁽¹⁾	PRODUCT STATUS ⁽²⁾	DEFINITIONS
Objective data	Development	This data sheet contains data from the objective specification for product development. Philips Semiconductors reserves the right to change the specification in any manner without notice.
Preliminary data	Qualification	This data sheet contains data from the preliminary specification. Supplementary data will be published at a later date. Philips Semiconductors reserves the right to change the specification without notice, in order to improve the design and supply the best possible product.
Product data	Production	This data sheet contains data from the product specification. Philips Semiconductors reserves the right to make changes at any time in order to improve the design, manufacturing and supply. Changes will be communicated according to the Customer Product/Process Change Notification (CPCN) procedure SNW-SQ-650A.

Notes

1. Please consult the most recently issued data sheet before initiating or completing a design.
2. The product status of the device(s) described in this data sheet may have changed since this data sheet was published. The latest information is available on the Internet at URL <http://www.semiconductors.philips.com>.

DEFINITIONS

Short-form specification — The data in a short-form specification is extracted from a full data sheet with the same type number and title. For detailed information see the relevant data sheet or data handbook.

Limiting values definition — Limiting values given are in accordance with the Absolute Maximum Rating System (IEC 60134). Stress above one or more of the limiting values may cause permanent damage to the device. These are stress ratings only and operation of the device at these or at any other conditions above those given in the Characteristics sections of the specification is not implied. Exposure to limiting values for extended periods may affect device reliability.

Application information — Applications that are described herein for any of these products are for illustrative purposes only. Philips Semiconductors make no representation or warranty that such applications will be suitable for the specified use without further testing or modification.

DISCLAIMERS

Life support applications — These products are not designed for use in life support appliances, devices, or systems where malfunction of these products can reasonably be expected to result in personal injury. Philips Semiconductors customers using or selling these products for use in such applications do so at their own risk and agree to fully indemnify Philips Semiconductors for any damages resulting from such application.

Right to make changes — Philips Semiconductors reserves the right to make changes, without notice, in the products, including circuits, standard cells, and/or software, described or contained herein in order to improve design and/or performance. Philips Semiconductors assumes no responsibility or liability for the use of any of these products, conveys no licence or title under any patent, copyright, or mask work right to these products, and makes no representations or warranties that these products are free from patent, copyright, or mask work right infringement, unless otherwise specified.

UHF power LDMOS transistor

BLF647

NOTES

Philips Semiconductors – a worldwide company

Contact information

For additional information please visit <http://www.semiconductors.philips.com>. Fax: +31 40 27 24825

For sales offices addresses send e-mail to: sales.addresses@www.semiconductors.philips.com.

© Koninklijke Philips Electronics N.V. 2001

SCA73

All rights are reserved. Reproduction in whole or in part is prohibited without the prior written consent of the copyright owner.

The information presented in this document does not form part of any quotation or contract, is believed to be accurate and reliable and may be changed without notice. No liability will be accepted by the publisher for any consequence of its use. Publication thereof does not convey nor imply any license under patent- or other industrial or intellectual property rights.

Printed in The Netherlands

613524/03/pp16

Date of release: 2001 Nov 27

Document order number: 9397 750 08838

Let's make things better.

**Philips
Semiconductors**



PHILIPS



LittleDiode supplies new, hard to find or obsolete electronic components and semiconductors all over the world.

With over two million different components listed you are sure to find the part you need.

Feel free to visit us today at our online store:

LittleDiode.com

Looking forward to providing you with the best possible service.