

# DATA SHEET

## **BLT82** UHF power transistor

Product specification

1996 Feb 05

# UHF power transistor

# BLT82

### FEATURES

- High efficiency
- High gain
- Internal pre-matched input.

### APPLICATIONS

- Hand-held radio equipment in common emitter class-AB operation for 900 MHz Time Division Multiple Axis (TDMA) communication systems.

### PINNING - SOT96-1

PIN	SYMBOL	DESCRIPTION
1, 8	b	base
2, 4, 5, 7	e	emitter
3, 6	c	collector

### DESCRIPTION

NPN silicon planar epitaxial transistor encapsulated in a plastic SOT96-1 (SO8) SMD package.

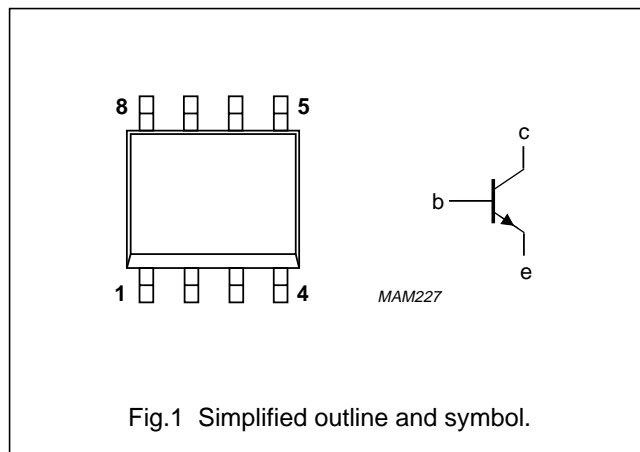

### QUICK REFERENCE DATA

RF performance at  $T_s \leq 60\text{ }^\circ\text{C}$  in a common emitter test circuit (see Fig.5).

MODE OF OPERATION	f (MHz)	V <sub>CE</sub> (V)	P <sub>L</sub> (W)	G <sub>p</sub> (dB)	$\eta_c$ (%)
Pulsed, class-AB	900	6	3.5	$\geq 8$ typ. 10	$\geq 50$ typ. 65
			2.8	$\geq 9$	$\geq 57$

UHF power transistor

BLT82

**LIMITING VALUES**

In accordance with the Absolute Maximum Rating System (IEC 134).

SYMBOL	PARAMETER	CONDITIONS	MIN.	MAX.	UNIT
$V_{CBO}$	collector-base voltage	open emitter	–	20	V
$V_{CEO}$	collector-emitter voltage	open base	–	10	V
$V_{EBO}$	emitter-base voltage	open collector	–	3.5	V
$I_C$	collector current (DC)		–	1	A
$P_{tot}$	total power dissipation	$T_s = 115\text{ °C}$ ; note 1	–	1.9	W
$T_{stg}$	storage temperature		–65	+150	°C
$T_j$	operating junction temperature		–	175	°C

**Note**

- $T_s$  is the temperature at the soldering point of the collector pin.

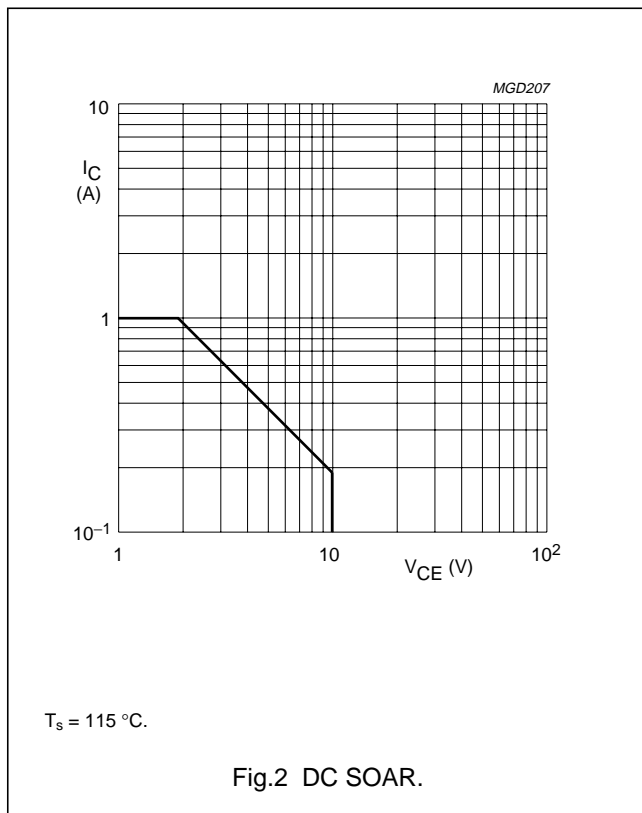

UHF power transistor

BLT82

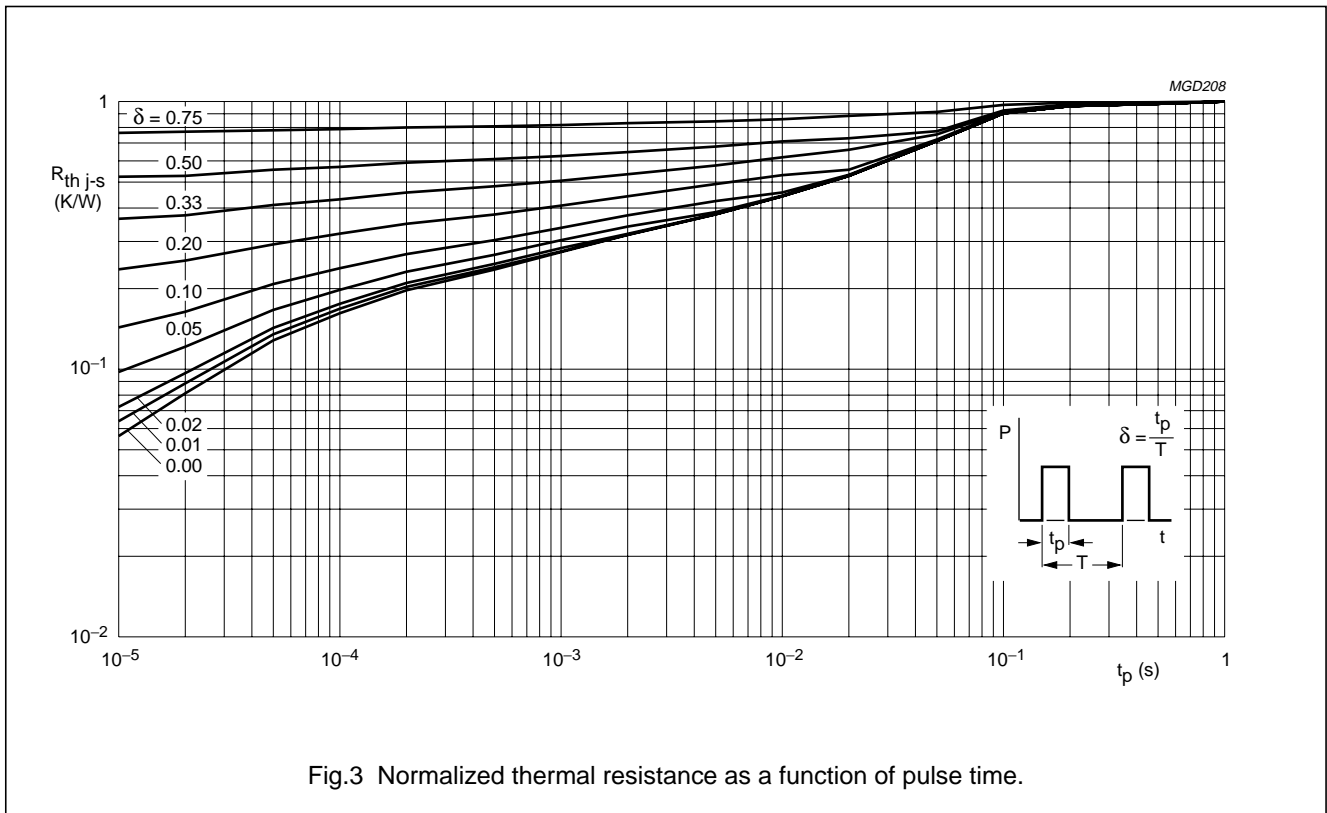

Fig.3 Normalized thermal resistance as a function of pulse time.

**THERMAL CHARACTERISTICS**

SYMBOL	PARAMETER	CONDITIONS	VALUE	UNIT
$R_{th\ j-s}$	thermal resistance from junction to soldering point	$P_{tot} = 1.9\ W$ ; $T_s = 115\ ^\circ C$ ; note 1	32	K/W

**Note**

- 1.  $T_s$  is the temperature at the soldering point of the collector pin.

**CHARACTERISTICS**

$T_j = 25\ ^\circ C$  unless otherwise specified.

SYMBOL	PARAMETER	CONDITIONS	MIN.	TYP.	MAX.	UNIT
$V_{(BR)CBO}$	collector-base breakdown voltage	open emitter; $I_C = 5\ mA$	20	—	—	V
$V_{(BR)CEO}$	collector-emitter breakdown voltage	open base; $I_C = 10\ mA$	10	—	—	V
$V_{(BR)EBO}$	emitter-base breakdown voltage	open collector; $I_E = 1\ mA$	3.5	—	—	V
$I_{CES}$	collector leakage current	$V_{CE} = 6\ V$ ; $V_{BE} = 0$	—	—	0.1	mA
$h_{FE}$	DC current gain	$V_{CE} = 5\ V$ ; $I_C = 100\ mA$	30	—	150	
$C_c$	collector capacitance	$V_{CB} = 6\ V$ ; $I_E = I_e = 0$ ; $f = 1\ MHz$	—	17	—	pF
$C_{re}$	feedback capacitance	$V_{CE} = 6\ V$ ; $I_C = 0$ ; $f = 1\ MHz$	—	10	—	pF

UHF power transistor

BLT82

**APPLICATION INFORMATION**

RF performance at  $T_s \leq 60^\circ\text{C}$  in a common emitter test circuit (see notes 1, 2 and Fig.5).

MODE OF OPERATION	f (MHz)	V <sub>CE</sub> (V)	I <sub>CQ</sub> (mA)	P <sub>L</sub> (W)	G <sub>p</sub> (dB)	η <sub>c</sub> (%)
Pulsed, class-AB; δ = 1 : 8; t <sub>p</sub> ≤ 5 ms	900	6	2	3.5	≥8 typ. 10	≥50 typ. 65
				2.8	≥9	≥57

**Notes**

1. T<sub>s</sub> is the temperature at the soldering point of the collector pin.
2. See also application report: "G.S.M. Power Amplifier for 900 MHz at 6 V (no.: RNR-T45-95-T-246)"

**Ruggedness in class-AB operation**

The BLT82 is capable of withstanding load mismatches corresponding to:

- VSWR = 6 : 1 through all phases under the following conditions: δ = 1 : 8; t<sub>p</sub> ≤ 5 ms; f = 900 MHz; V<sub>CE</sub> = 8.3 V; P<sub>L</sub> = 4 W.
- VSWR = 10 : 1 through all phases under the following conditions: δ = 1 : 8; t<sub>p</sub> ≤ 5 ms; f = 900 MHz; V<sub>CE</sub> = 8.6 V; P<sub>L</sub> = 2.8 W.

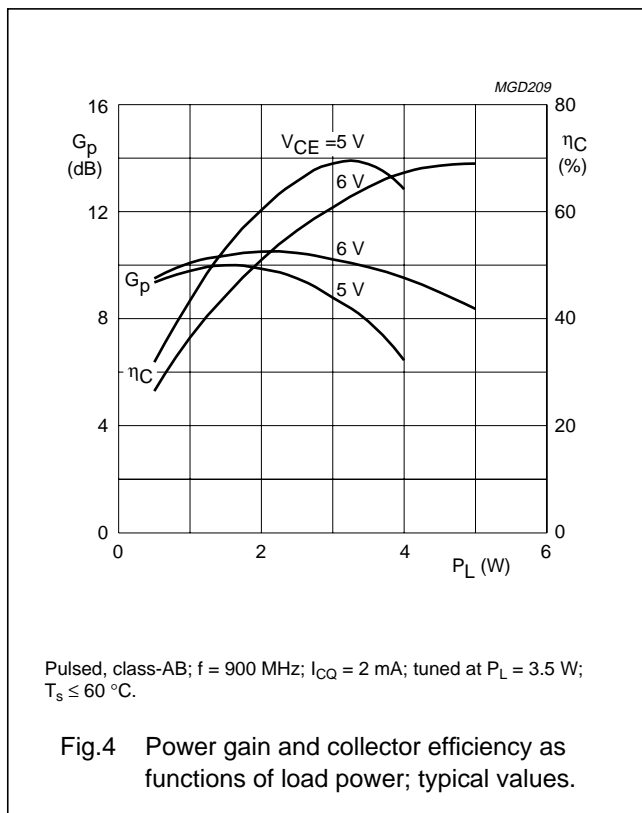

# UHF power transistor

# BLT82

## Test circuit information

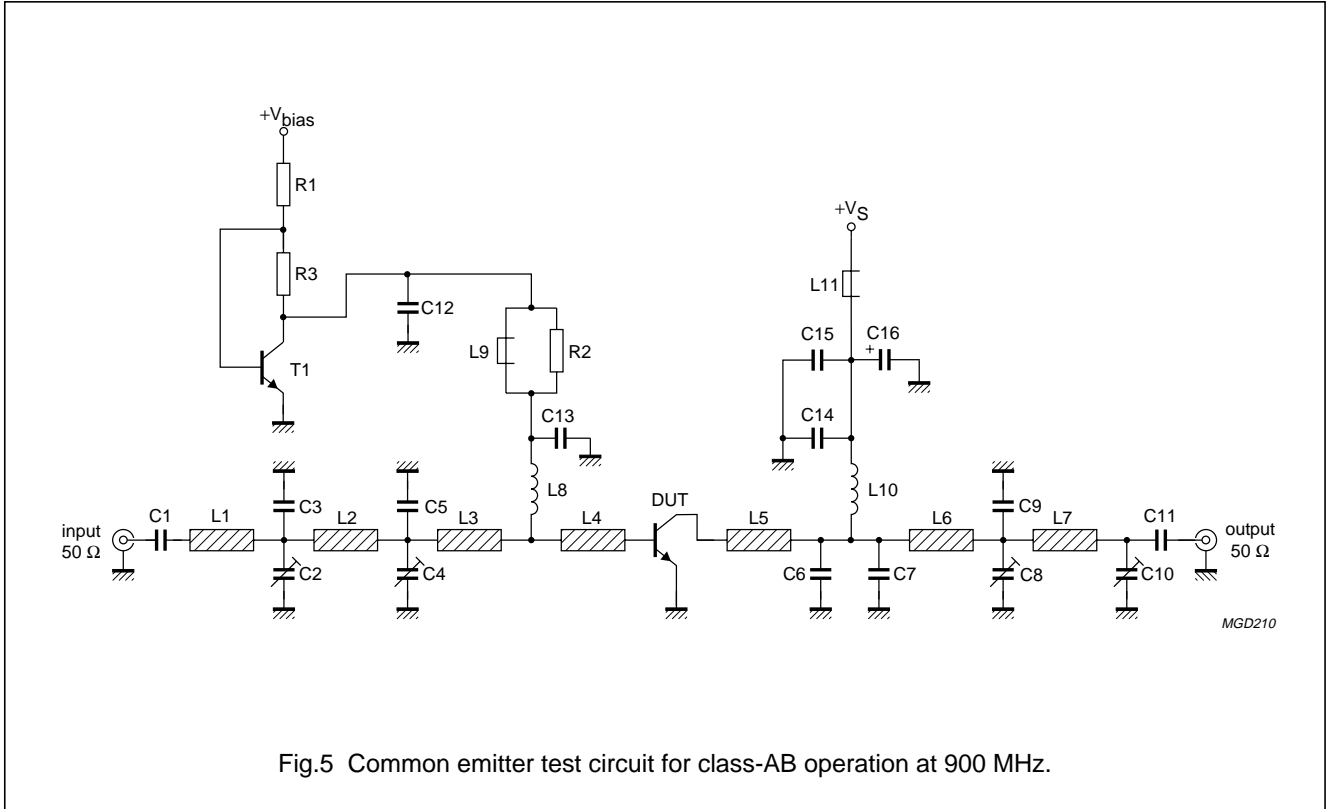

Fig.5 Common emitter test circuit for class-AB operation at 900 MHz.

## UHF power transistor

BLT82

## List of components used in test circuit (see Figs 5 and 6)

COMPONENT	DESCRIPTION	VALUE	DIMENSIONS	CATALOGUE No.
C1, C11	multilayer ceramic chip capacitor; note 1	62 pF		
C2, C4, C8, C10	film dielectric trimmer	0.8 to 3.5 pF		2222 809 05001
C3	multilayer ceramic chip capacitor; note 1	1 pF		
C5	multilayer ceramic chip capacitor; note 1	8.2 pF		
C6, C7	multilayer ceramic chip capacitor; note 1	6.2 pF		
C9	multilayer ceramic chip capacitor; note 1	1.2 pF		
C12	multilayer ceramic chip cap.; note 2	10 nF		
C13, C14	multilayer ceramic chip cap.; note 1	18 pF		
C15	multilayer ceramic chip cap.; note 2	39 nF		
C16	electrolytic capacitor	2200 $\mu$ F		
L1	stripline; note 3	50 $\Omega$	length 20.6 mm width 5 mm	
L2	stripline; note 3	50 $\Omega$	length 27.4 mm width 5 mm	
L3, L4	stripline; note 3	50 $\Omega$	length 4 mm width 5 mm	
L5	stripline; note 3	50 $\Omega$	length 5.8 mm width 5 mm	
L6	stripline; note 3	50 $\Omega$	length 12.4 mm width 5 mm	
L7	stripline; note 3	50 $\Omega$	length 36 mm width 5 mm	
L8	8 turns enamelled 1 mm copper wire	80 nH	internal dia. 3 mm leads 2 $\times$ 5 mm	
L9, L11	grade 3B Ferroxcube wideband HF choke			4132 020 36640
L10	4 turns enamelled 1 mm copper wire	35 nH	internal dia. 3 mm leads 2 $\times$ 5 mm	
R1	metal film resistor	0.6 W, 38.3 $\Omega$		2322 156 13839
R2	metal film resistor	0.6 W, 10 $\Omega$		2322 156 11009
R3	metal film resistor	0.6 W, 1 $\Omega$		2322 156 11008
T1	NPN transistor	BC817		

## Notes

- American Technical Ceramics type 100B or capacitor of same quality.
- American Technical Ceramics type 200B or capacitor of same quality.
- The striplines are on a double copper-clad printed-circuit board, with DUROID dielectric ( $\epsilon_r = 2.2$ ); thickness  $\frac{1}{32}$ "; thickness of the copper sheet 2  $\times$  35  $\mu$ m.

UHF power transistor

BLT82

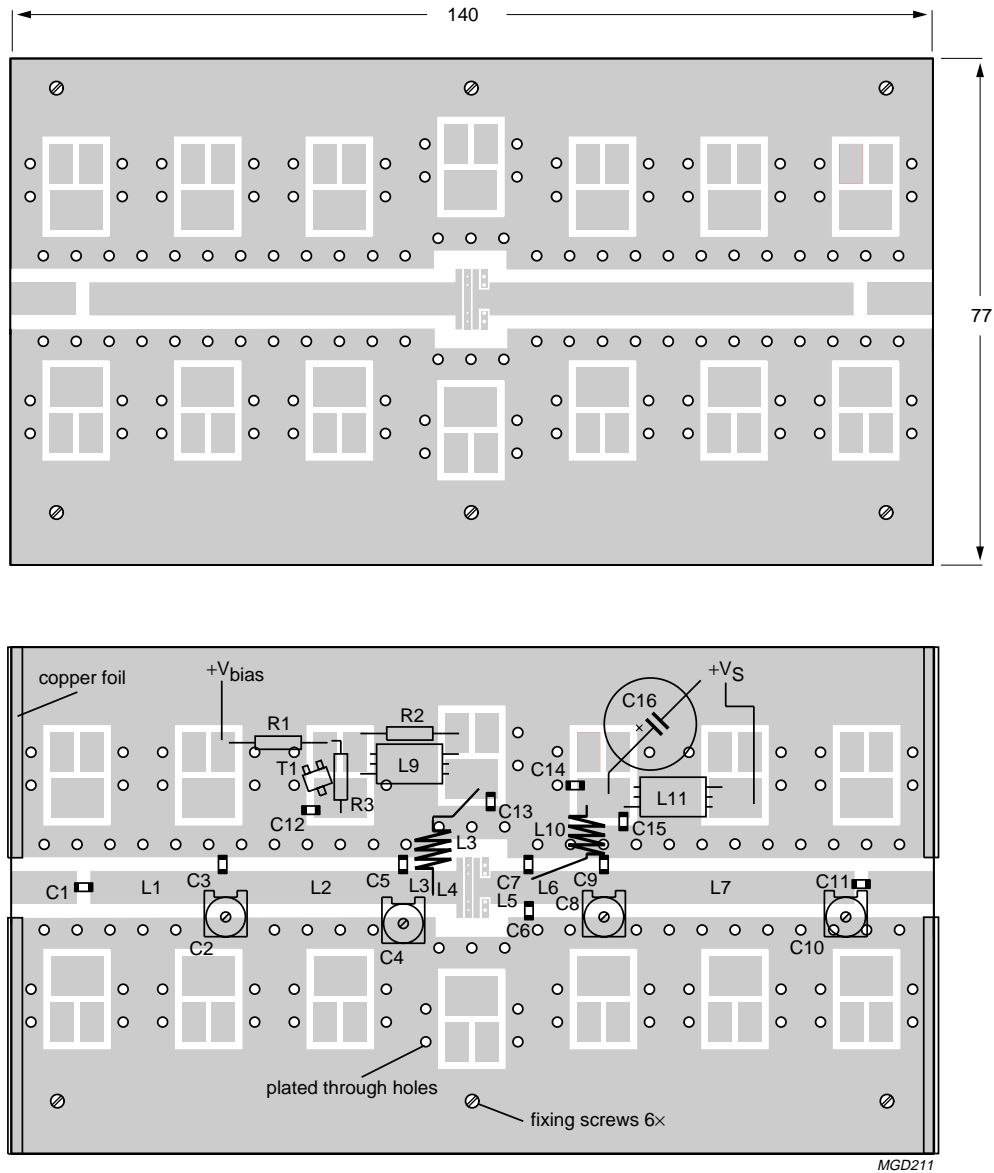

Dimensions in mm.

The components are situated on one side of the copper-clad PCB, the other side is unetched and serves as a ground plane. Earth connections from the component side to the ground plane are made by fixing screws, through metallization and copper straps around the board.

Fig.6 Printed-circuit board and component lay-out for 900 MHz class-AB test circuit in Fig.5.

UHF power transistor

BLT82

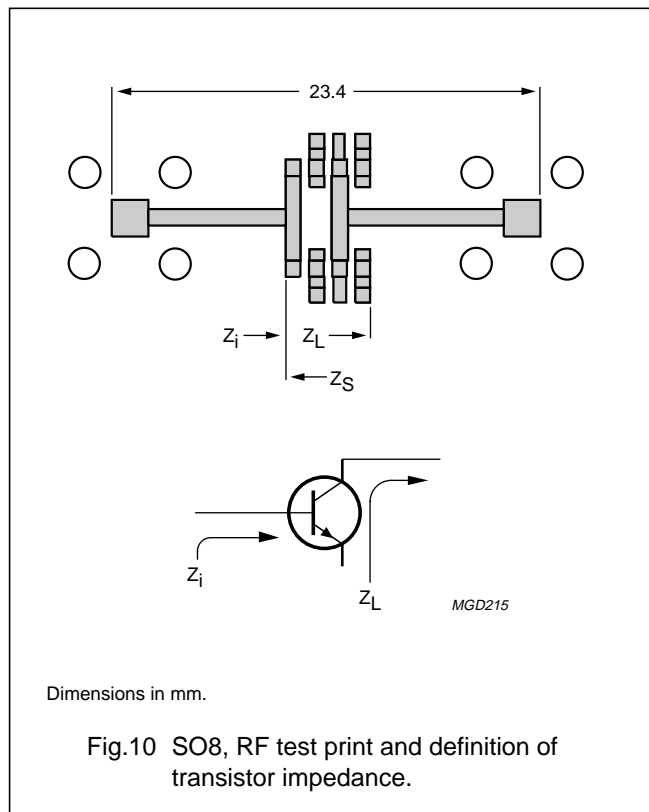
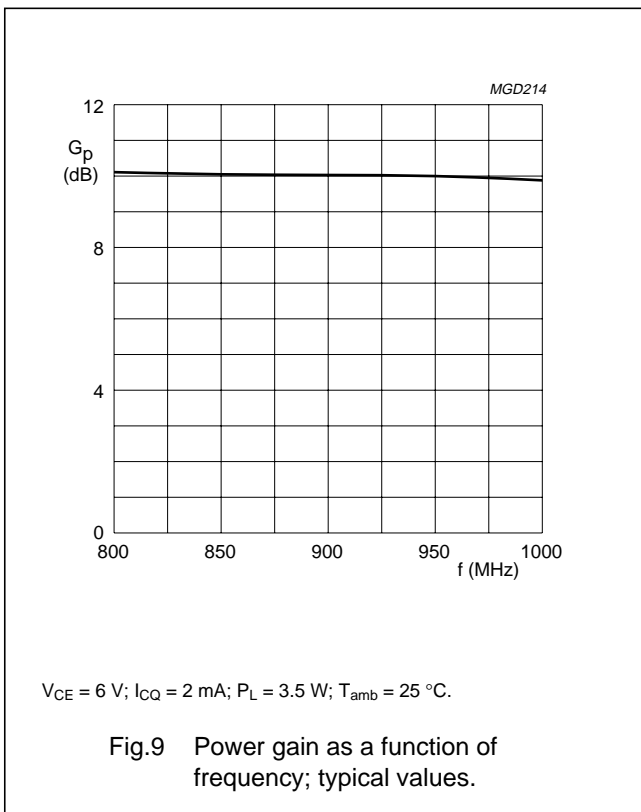
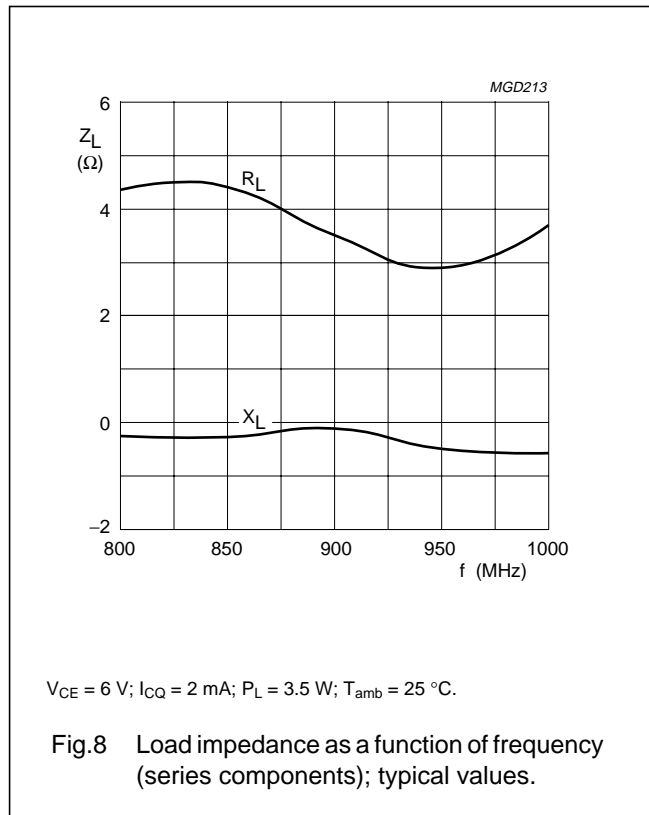
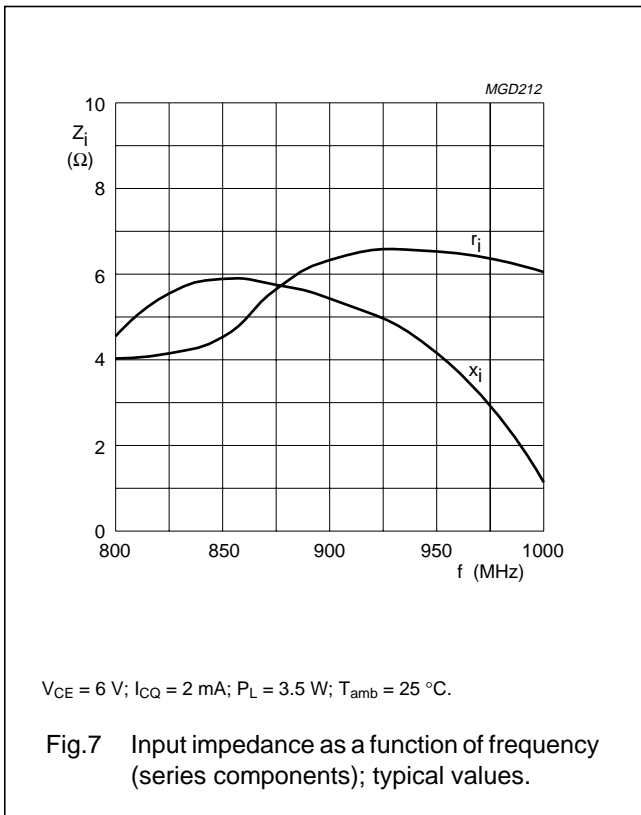

UHF power transistor

BLT82

PACKAGE OUTLINE

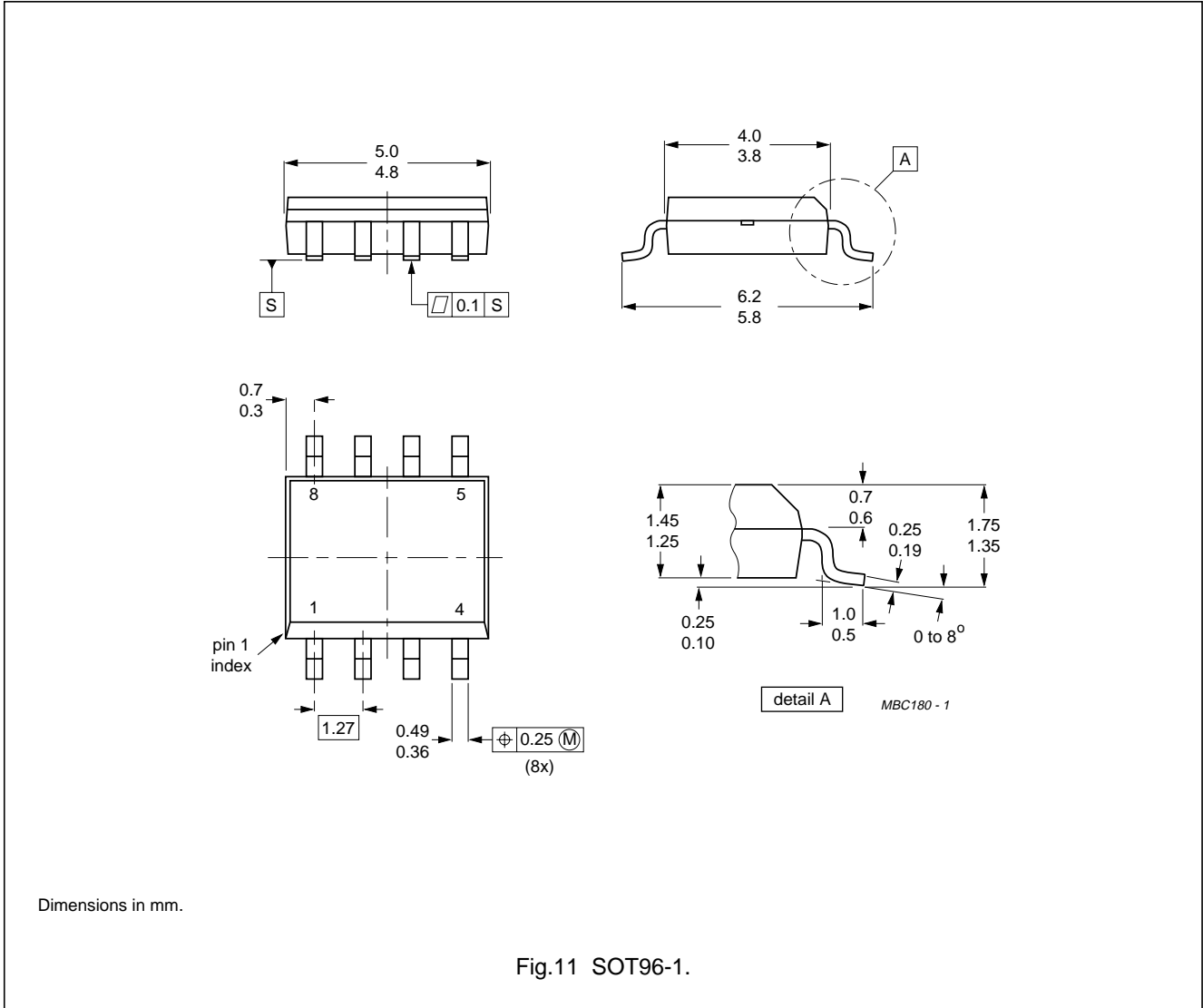

## UHF power transistor

BLT82

**DEFINITIONS**

<b>Data Sheet Status</b>	
Objective specification	This data sheet contains target or goal specifications for product development.
Preliminary specification	This data sheet contains preliminary data; supplementary data may be published later.
Product specification	This data sheet contains final product specifications.
<b>Limiting values</b>	
Limiting values given are in accordance with the Absolute Maximum Rating System (IEC 134). Stress above one or more of the limiting values may cause permanent damage to the device. These are stress ratings only and operation of the device at these or at any other conditions above those given in the Characteristics sections of the specification is not implied. Exposure to limiting values for extended periods may affect device reliability.	
<b>Application information</b>	
Where application information is given, it is advisory and does not form part of the specification.	

**LIFE SUPPORT APPLICATIONS**

These products are not designed for use in life support appliances, devices, or systems where malfunction of these products can reasonably be expected to result in personal injury. Philips customers using or selling these products for use in such applications do so at their own risk and agree to fully indemnify Philips for any damages resulting from such improper use or sale.



LittleDiode supplies new, hard to find or obsolete electronic components and semiconductors all over the world.

With over two million different components listed you are sure to find the part you need.

Feel free to visit us today at our online store:

[LittleDiode.com](http://LittleDiode.com)

Looking forward to providing you with the best possible service.