

# DATA SHEET

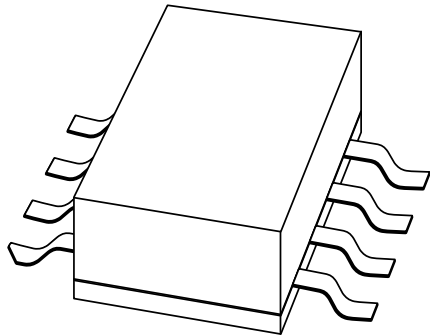

## **BLV2042** UHF power transistor

Product specification  
Supersedes data of 1997 July 11

2000 May 08

# UHF power transistor

# BLV2042

### FEATURES

- Emitter ballasting resistors for optimum temperature profile
- Gold metallization ensures excellent reliability
- Internal input matching to achieve high power gain and easy design of wideband circuits.

### APPLICATIONS

- Common emitter class-AB operation in base stations in the 1800 to 1990 MHz frequency range.

### DESCRIPTION

NPN silicon planar epitaxial power transistor in an 8-lead SOT409A SMD package with ceramic cap. All leads are isolated from the mounting base.

### PINNING - SOT409A

PIN	DESCRIPTION
1, 4, 5 and 8	emitter
2 and 3	base
6 and 7	collector

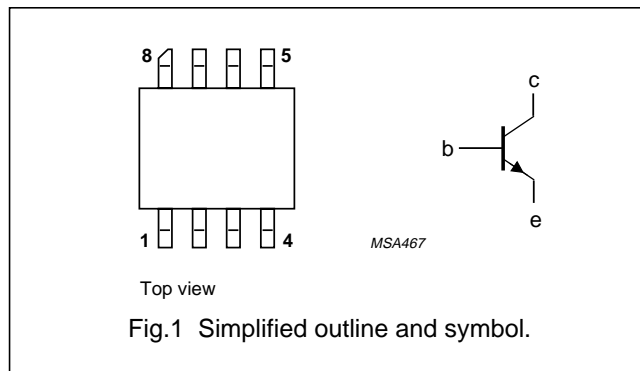

### QUICK REFERENCE DATA

RF performance at  $T_{mb} = 25\text{ }^\circ\text{C}$  in a common emitter test circuit.

MODE OF OPERATION	f (MHz)	$V_{CE}$ (V)	$P_L$ (W)	$G_p$ (dB)	$\eta_c$ (%)	$d_{im}$ (dBc)
CW, class-AB	1950	26	4	$\geq 11$	$\geq 40$	–
CW, class-AB	1990	26	4	$\geq 11$	$\geq 40$	–
2-tone, class-AB	$f_1 = 1950; f_2 = 1950.1$	26	4 (PEP)	typ. 14	typ. 35	typ. -30

UHF power transistor

BLV2042

**LIMITING VALUES**

In accordance with the Absolute Maximum Rating System (IEC 60134).

SYMBOL	PARAMETER	CONDITIONS	MIN.	MAX.	UNIT
$V_{CBO}$	collector-base voltage	open emitter	–	60	V
$V_{CEO}$	collector-emitter voltage	open base	–	28	V
$V_{EBO}$	emitter-base voltage	open collector	–	4	V
$I_C$	collector current (DC)		–	1.2	A
$I_{C(AV)}$	collector current (average)		–	1.2	A
$P_{tot}$	total power dissipation	$T_{mb} = 25\text{ °C}$ ; note 1	–	14.6	W
$T_{stg}$	storage temperature		–65	+150	°C
$T_j$	operating junction temperature		–	200	°C

**Note**

1. Transistor with metallized ground plane mounted on a printed-circuit board, see *“Mounting and soldering recommendations in the General part of the associated handbook”*.

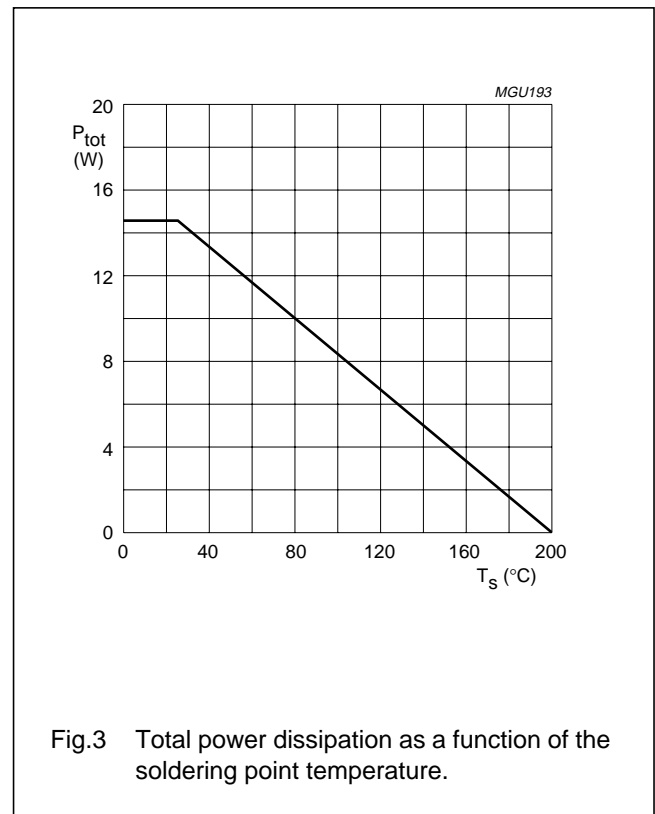
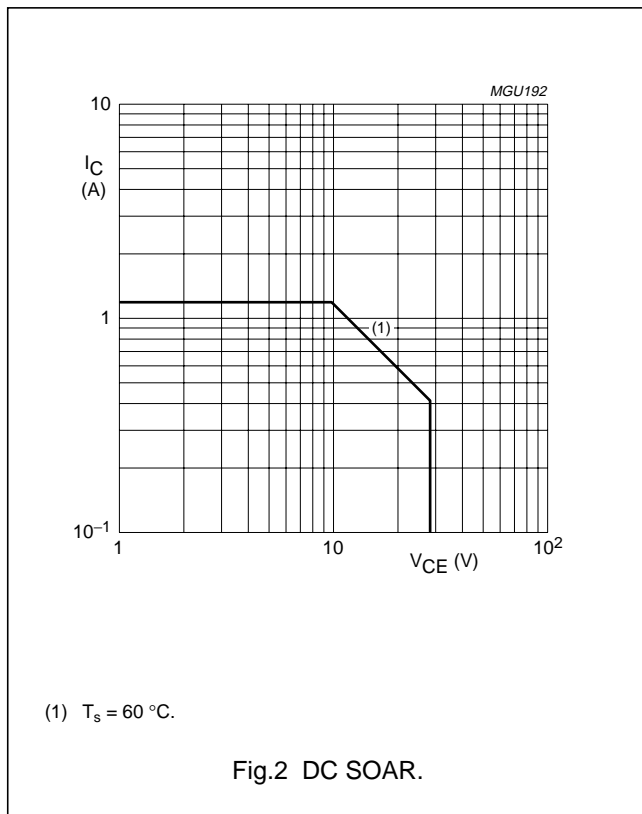

UHF power transistor

BLV2042

**THERMAL CHARACTERISTICS**

SYMBOL	PARAMETER	CONDITIONS	VALUE	UNIT
$R_{th\ j-mb}$	thermal resistance from junction to mounting base	$P_{tot} = 14.6\ W$ ; $T_{mb} = 25\ ^\circ C$ ; note 1	12	K/W

**Note**

1. Transistor with metallized ground plane mounted on a printed-circuit board, see "Mounting and soldering recommendations in the General part of the associated handbook".

**CHARACTERISTICS**

$T_j = 25\ ^\circ C$  unless otherwise specified.

SYMBOL	PARAMETER	CONDITIONS	MIN.	TYP.	MAX.	UNIT
$V_{(BR)CBO}$	collector-base breakdown voltage	open emitter; $I_C = 5\ mA$	60	–	–	V
$V_{(BR)CEO}$	collector-emitter breakdown voltage	open base; $I_C = 10\ mA$	28	–	–	V
$V_{(BR)EBO}$	emitter-base breakdown voltage	open collector; $I_E = 0.5\ mA$	4	–	–	V
$I_{CES}$	collector leakage current	$V_{CE} = 26\ V$ ; $V_{BE} = 0$	–	–	1.3	mA
$h_{FE}$	DC current gain	$V_{CE} = 26\ V$ ; $I_C = 600\ mA$	30	–	120	
$C_c$	collector capacitance	$V_{CB} = 26\ V$ ; $I_E = i_e = 0$ ; $f = 1\ MHz$	–	6	–	pF
$C_{re}$	feedback capacitance	$V_{CE} = 26\ V$ ; $I_C = 0$ ; $f = 1\ MHz$	–	2.5	–	pF

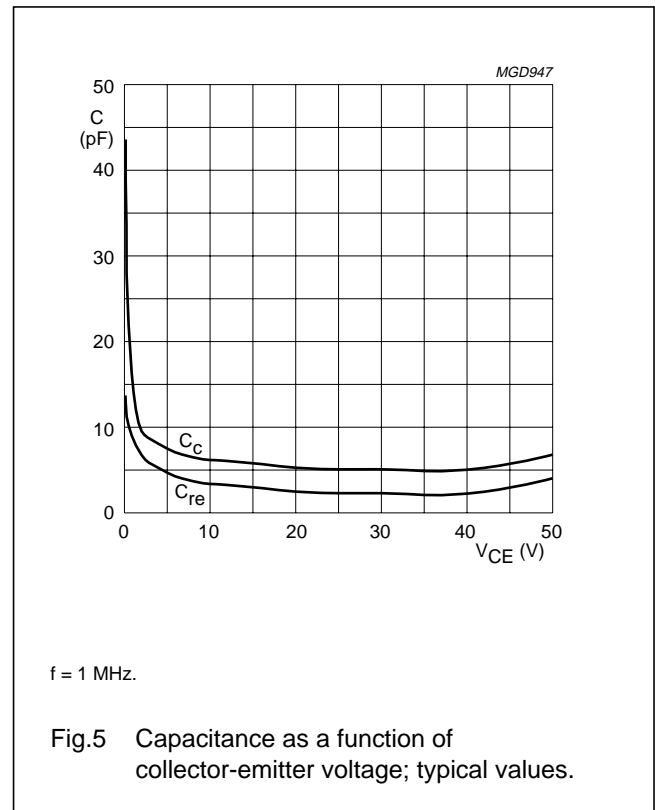
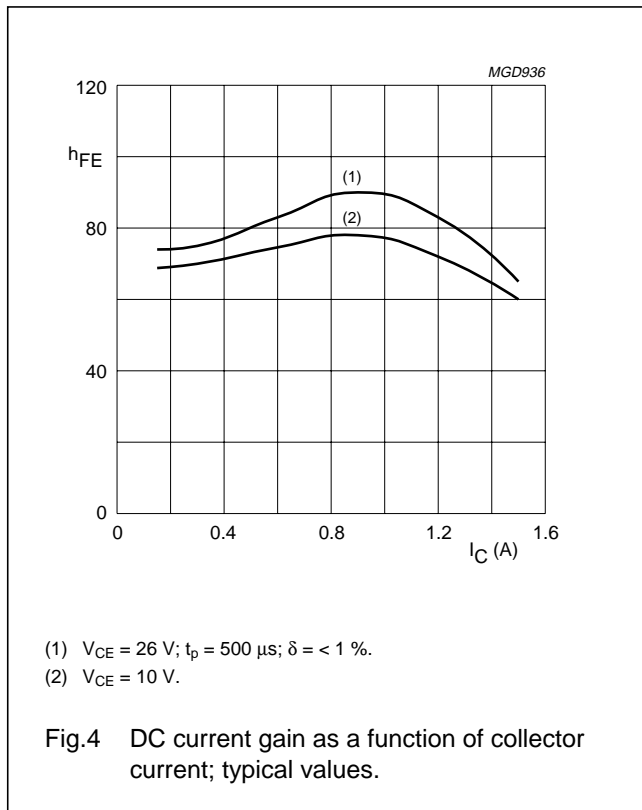

UHF power transistor

BLV2042

APPLICATION INFORMATION

RF performance at  $T_{mb} = 25\text{ }^{\circ}\text{C}$  in a common emitter test circuit.

MODE OF OPERATION	f (MHz)	V <sub>CE</sub> (V)	I <sub>CQ</sub> (mA)	P <sub>L</sub> (W)	G <sub>p</sub> (dB)	η <sub>C</sub> (%)	d <sub>im</sub> (dBc)
CW, class-AB	1950	26	15	4	≥11 typ. 13	≥40 typ. 43	–
CW, class-AB	1990	26	15	4	≥11	≥40	–
2-tone, class-AB	f <sub>1</sub> = 1950; f <sub>2</sub> = 1950.1	26	15	4 (PEP)	typ. 14	typ. 35	typ. –30

Ruggedness in class-AB operation

The BLV2042 is capable of withstanding a load mismatch corresponding to VSWR = 20 : 1 through all phases under the following conditions: f = 1950 MHz; V<sub>CE</sub> = 26 V; I<sub>CQ</sub> = 15 mA; P<sub>L</sub> = 4 W; T<sub>mb</sub> = 25 °C.

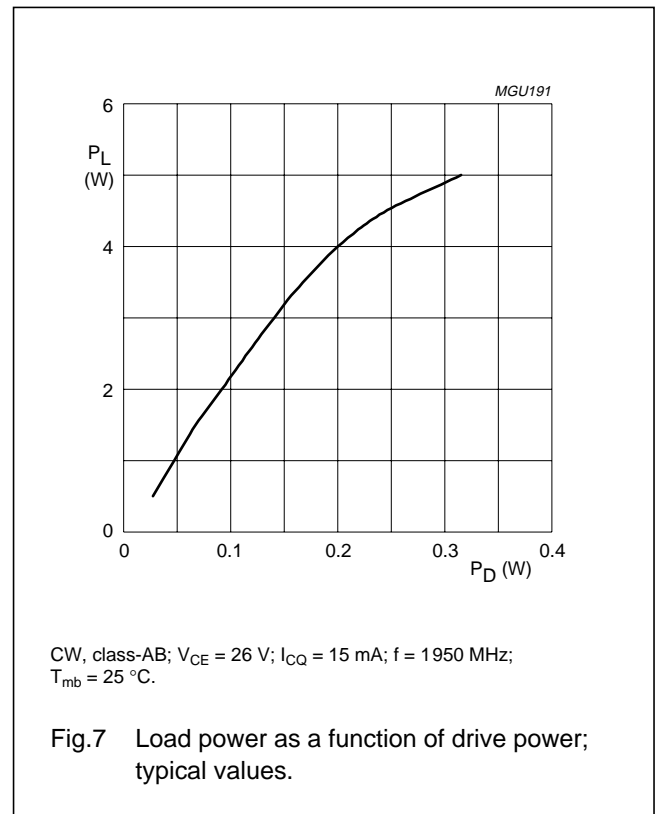
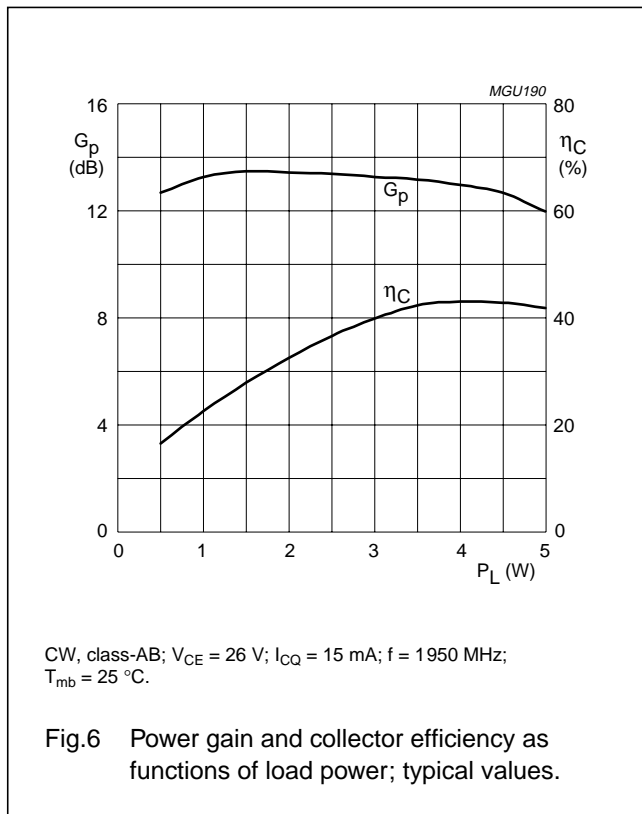

UHF power transistor

BLV2042

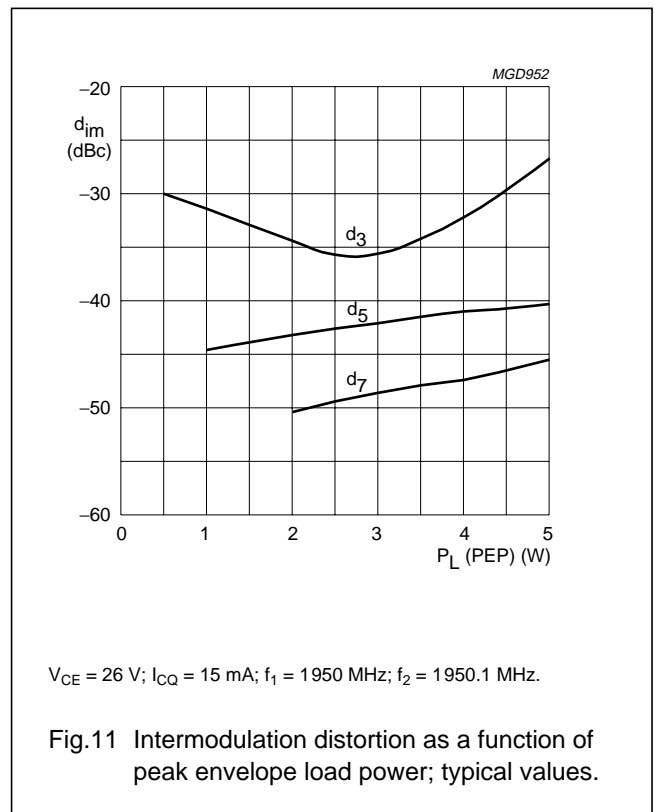
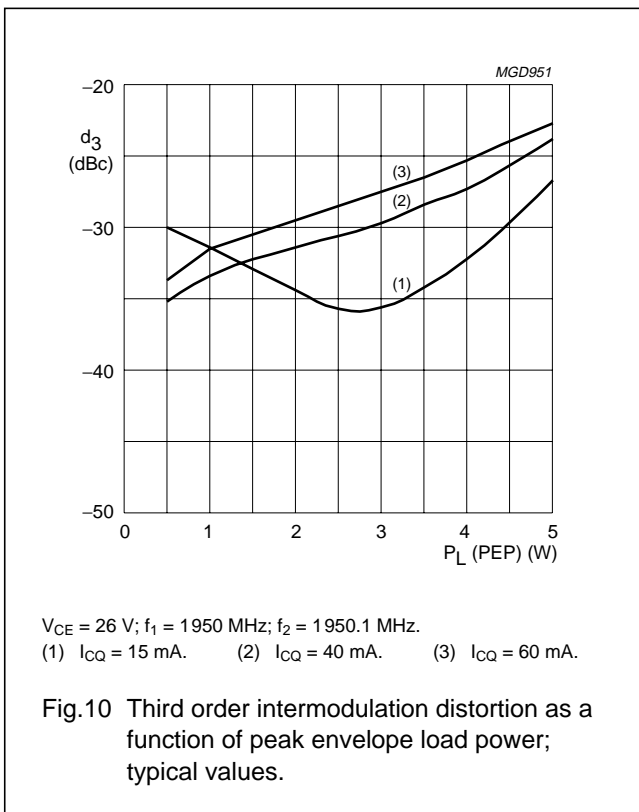
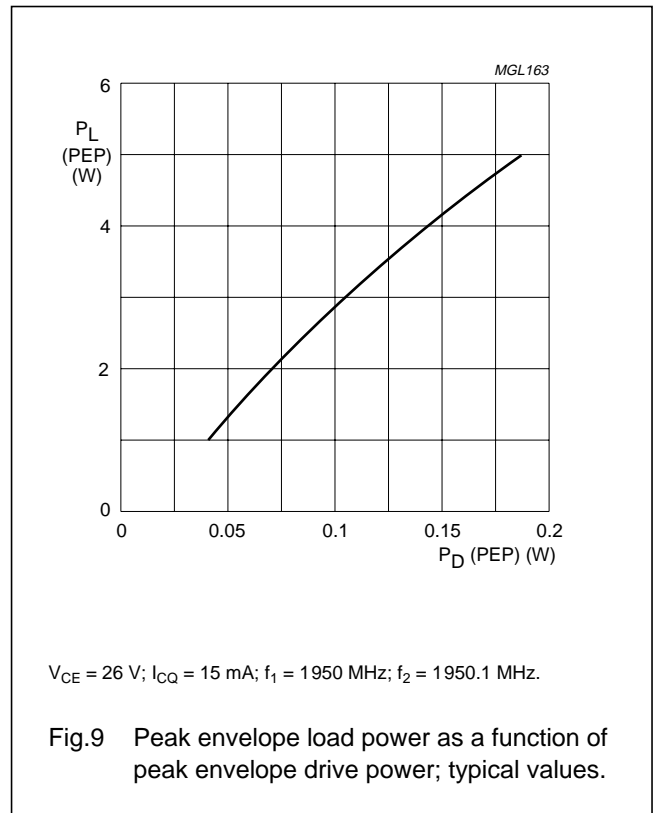
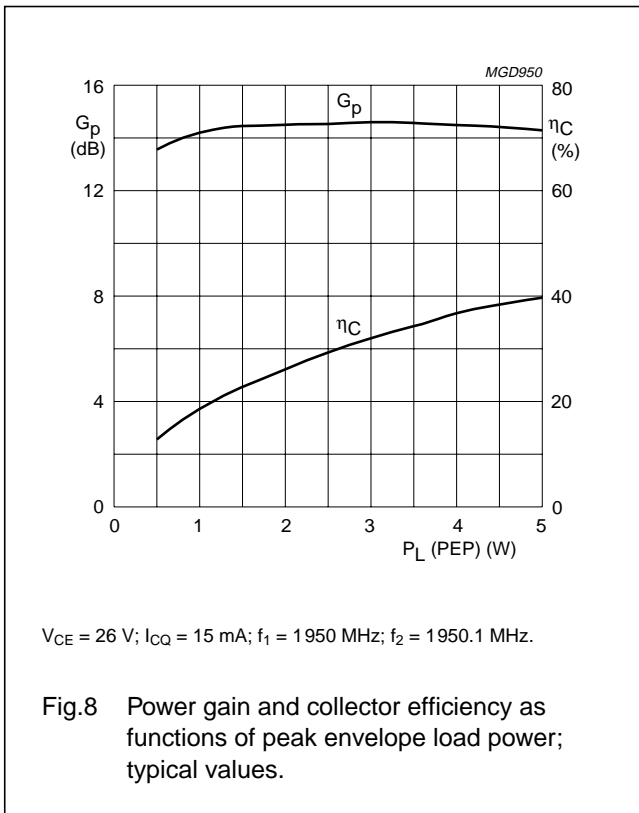

# UHF power transistor

# BLV2042

## Test circuit information

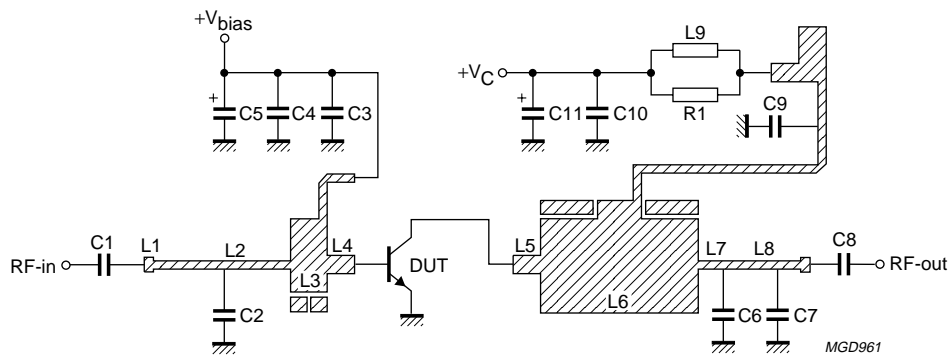

Fig.12 Class-AB test circuit at 1950 MHz.

## UHF power transistor

BLV2042

## List of components (see Figs 12 and 13)

COMPONENT	DESCRIPTION	VALUE	DIMENSIONS	CATALOGUE No.
C1, C9	multilayer ceramic chip capacitor; note 1	100 pF		
C2, C6	multilayer ceramic chip capacitor; note 2	3 pF		
C3, C8	multilayer ceramic chip capacitor; note 2	27 pF		
C4, C10	multilayer ceramic chip capacitor	100 nF		2222 581 16641
C5, C11	tantalum SMD capacitor	47 $\mu$ F; 35 V		
C7	multilayer ceramic chip capacitor; note 2	1.2 pF		
L1	stripline; note 3	50 $\Omega$	length 9.9 mm width 0.91 mm	
L2	stripline; note 3	50 $\Omega$	length 6.66 mm width 0.91 mm	
L3	stripline; note 3	10 $\Omega$	length 4 mm width 8 mm	
L4	stripline; note 3	31 $\Omega$	length 3 mm width 2 mm	
L5	stripline; note 3	31 $\Omega$	length 3 mm width 2 mm	
L6	stripline; note 3	8.3 $\Omega$	length 17.25 mm width 10.3 mm	
L7	stripline; note 3	50 $\Omega$	length 2.42 mm width 0.91 mm	
L8	stripline; note 3	50 $\Omega$	length 6.14 mm width 0.91 mm	
L9	grade 4S2 ferroxcube chip-bead			4330 030 36301
R1	metal film resistor	100 $\Omega$ ; 0.4 W		

## Notes

1. American Technical Ceramics type 100B or capacitor of the same quality.
2. American Technical Ceramics type 100A or capacitor of the same quality.
3. The striplines are on a double copper-clad printed-circuit board with epoxy fibreglass dielectric ( $\epsilon_r = 6.15$ ); thickness 0.64 mm.

UHF power transistor

BLV2042

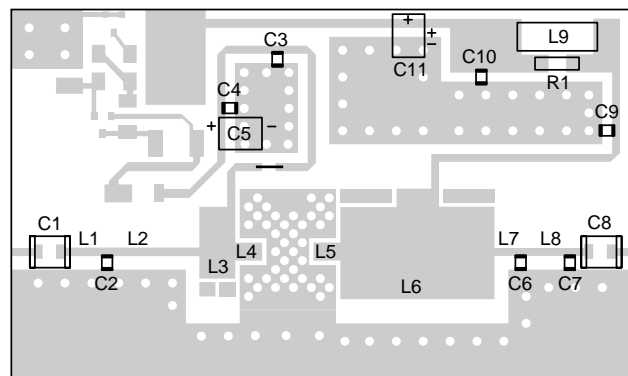
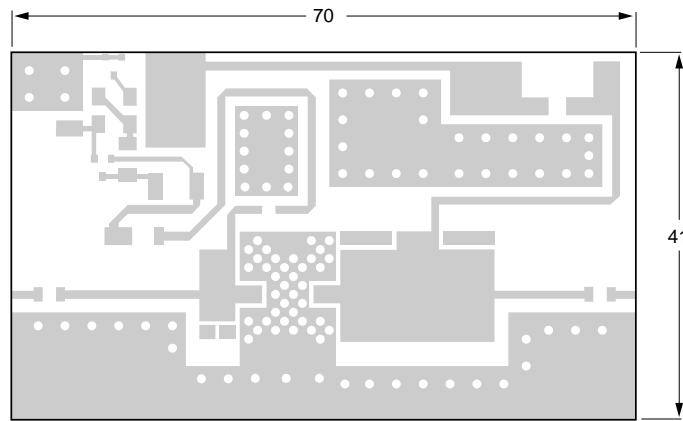

MGD965

Dimensions in mm.

The components are situated on one side of the copper-clad epoxy fibreglass board, the other side is not etched and serves as a ground plane. Earth connections from the component side to the ground plane are made by through metallization.

Fig.13 Component layout for 1950 MHz class-AB test circuit.

UHF power transistor

BLV2042

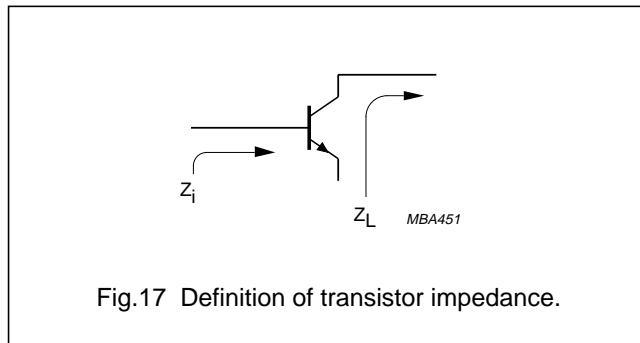
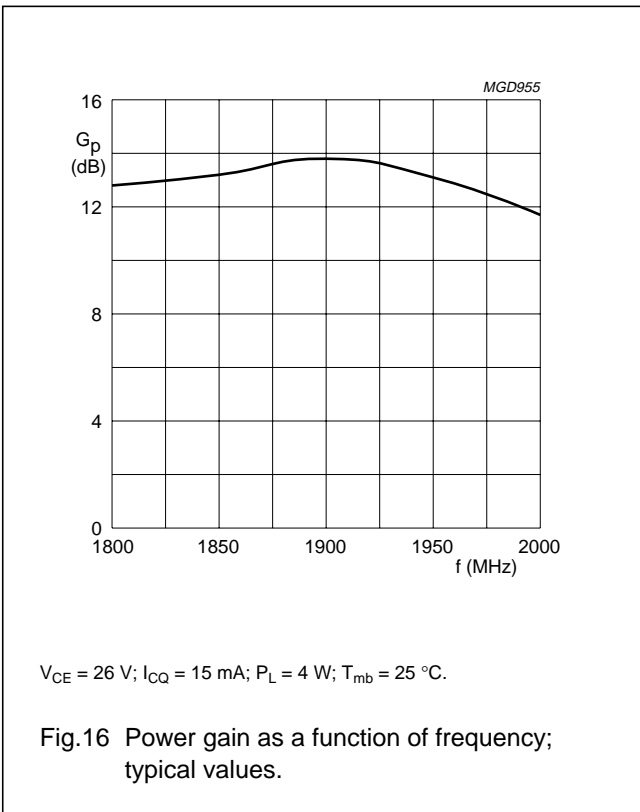
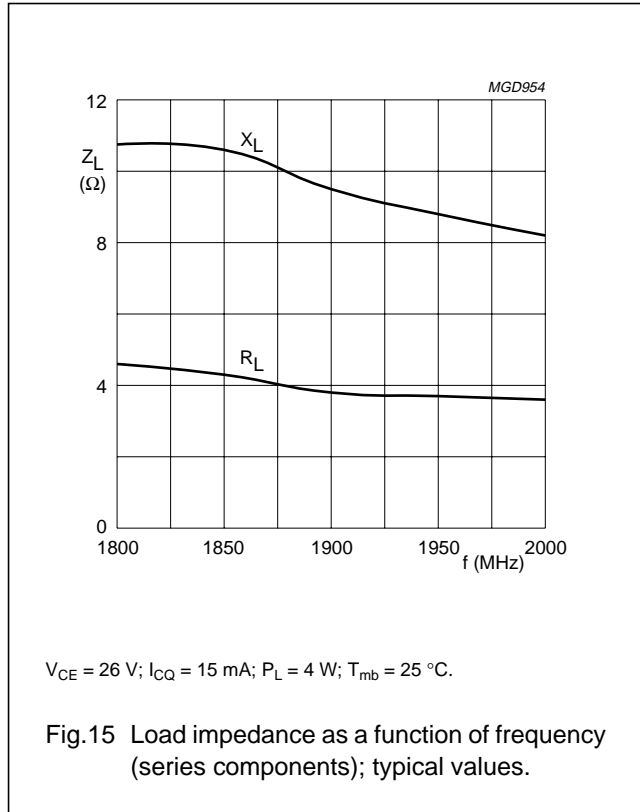
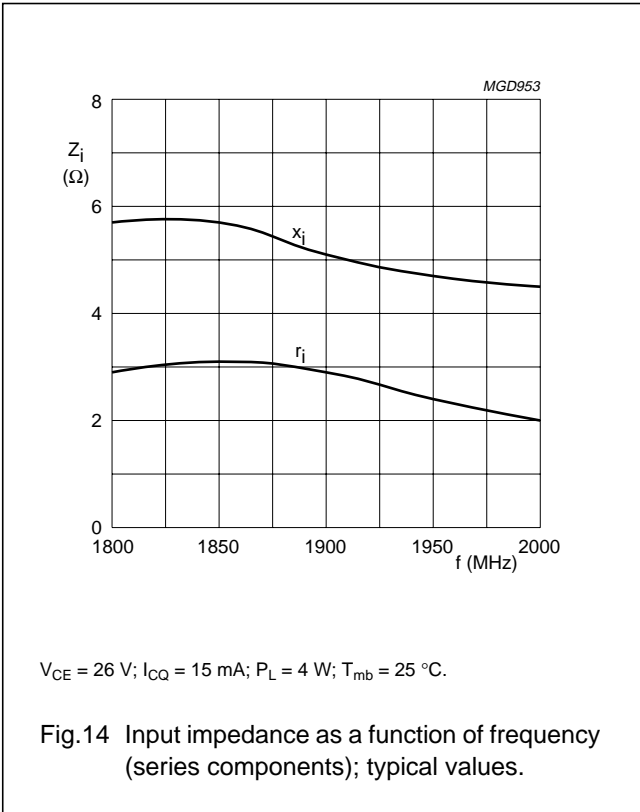

**MOUNTING RECOMMENDATIONS**

Heat from the device is transferred via the leads and the metallized underside. For optimum heat transfer it is recommended that the transistor be mounted on a grounded metallized area on the component side of the printed-circuit board. This metallized area should contain a large number of metallized, solder-filled through-holes. The non-component side of the printed-circuit board forms a ground plane. When the printed-circuit board is mounted on the heatsink using heatsink compound, a thermal resistance from mounting base to heatsink of 0.9 K/W can be attained.

UHF power transistor

BLV2042

PACKAGE OUTLINE

Ceramic surface mounted package; 8 leads

SOT409A

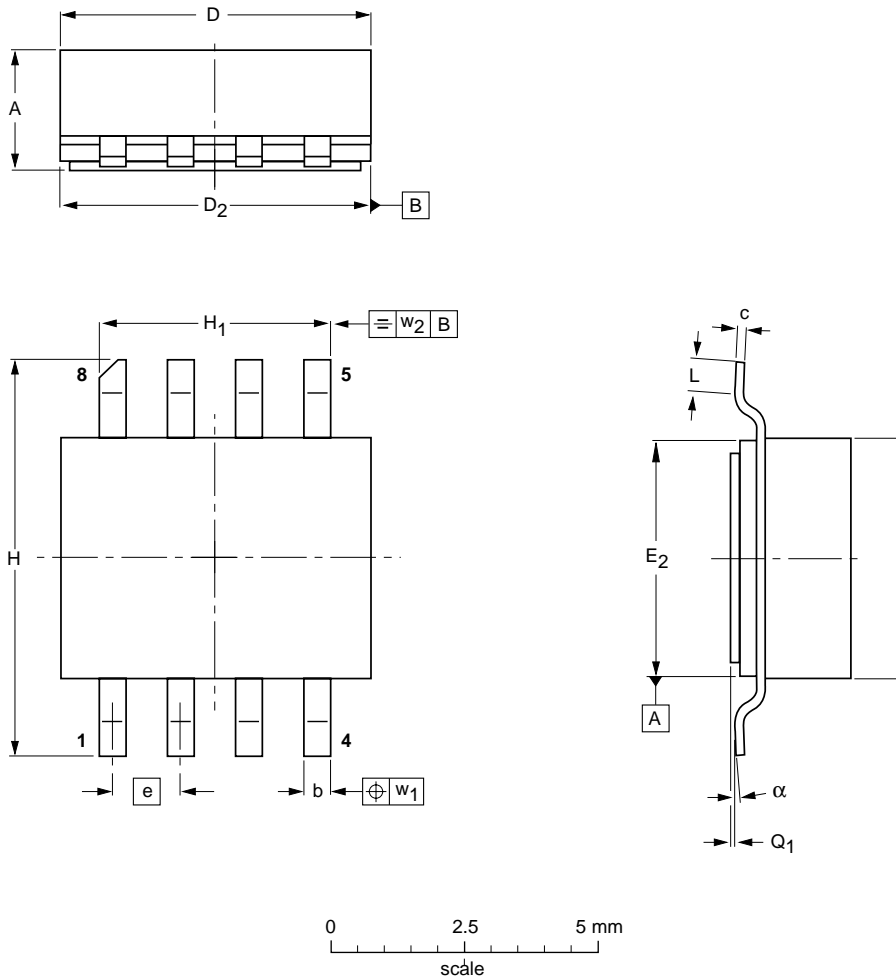

DIMENSIONS (millimetre dimensions are derived from the original inch dimensions)

UNIT	A	b	c	D	D <sub>2</sub>	E	E <sub>2</sub>	e	H	H <sub>1</sub>	L	Q <sub>1</sub>	w <sub>1</sub>	w <sub>2</sub>	$\alpha$
mm	2.36 2.06	0.58 0.43	0.23 0.18	5.94 5.03	5.16 5.00	4.93 4.01	4.14 3.99	1.27	7.47 7.26	4.39 4.24	1.02 0.51	0.10 0.00	0.25	0.25	7° 0°
inches	0.093 0.081	0.023 0.017	0.009 0.007	0.234 0.198	0.203 0.197	0.194 0.158	0.163 0.157	0.050	0.294 0.286	0.173 0.167	0.040 0.020	0.004 0.000	0.010	0.010	7° 0°

OUTLINE VERSION	REFERENCES				EUROPEAN PROJECTION	ISSUE DATE
	IEC	JEDEC	EIAJ			
SOT409A						98-01-27

## UHF power transistor

BLV2042

## DATA SHEET STATUS

DATA SHEET STATUS	PRODUCT STATUS	DEFINITIONS <sup>(1)</sup>
Objective specification	Development	This data sheet contains the design target or goal specifications for product development. Specification may change in any manner without notice.
Preliminary specification	Qualification	This data sheet contains preliminary data, and supplementary data will be published at a later date. Philips Semiconductors reserves the right to make changes at any time without notice in order to improve design and supply the best possible product.
Product specification	Production	This data sheet contains final specifications. Philips Semiconductors reserves the right to make changes at any time without notice in order to improve design and supply the best possible product.

## Note

1. Please consult the most recently issued data sheet before initiating or completing a design.

## DEFINITIONS

**Short-form specification** — The data in a short-form specification is extracted from a full data sheet with the same type number and title. For detailed information see the relevant data sheet or data handbook.

**Limiting values definition** — Limiting values given are in accordance with the Absolute Maximum Rating System (IEC 60134). Stress above one or more of the limiting values may cause permanent damage to the device. These are stress ratings only and operation of the device at these or at any other conditions above those given in the Characteristics sections of the specification is not implied. Exposure to limiting values for extended periods may affect device reliability.

**Application information** — Applications that are described herein for any of these products are for illustrative purposes only. Philips Semiconductors make no representation or warranty that such applications will be suitable for the specified use without further testing or modification.

## DISCLAIMERS

**Life support applications** — These products are not designed for use in life support appliances, devices, or systems where malfunction of these products can reasonably be expected to result in personal injury. Philips Semiconductors customers using or selling these products for use in such applications do so at their own risk and agree to fully indemnify Philips Semiconductors for any damages resulting from such application.

**Right to make changes** — Philips Semiconductors reserves the right to make changes, without notice, in the products, including circuits, standard cells, and/or software, described or contained herein in order to improve design and/or performance. Philips Semiconductors assumes no responsibility or liability for the use of any of these products, conveys no licence or title under any patent, copyright, or mask work right to these products, and makes no representations or warranties that these products are free from patent, copyright, or mask work right infringement, unless otherwise specified.

UHF power transistor

BLV2042

---

**NOTES**

UHF power transistor

BLV2042

---

**NOTES**

UHF power transistor

BLV2042

---

**NOTES**

# Philips Semiconductors – a worldwide company

**Argentina:** see South America

**Australia:** 3 Figtree Drive, HOME BUSH, NSW 2140,  
Tel. +61 2 9704 8141, Fax. +61 2 9704 8139

**Austria:** Computerstr. 6, A-1101 WIEN, P.O. Box 213,  
Tel. +43 1 60 101 1248, Fax. +43 1 60 101 1210

**Belarus:** Hotel Minsk Business Center, Bld. 3, r. 1211, Volodarski Str. 6,  
220050 MINSK, Tel. +375 172 20 0733, Fax. +375 172 20 0773

**Belgium:** see The Netherlands

**Brazil:** see South America

**Bulgaria:** Philips Bulgaria Ltd., Energoproject, 15th floor,  
51 James Bourchier Blvd., 1407 SOFIA,  
Tel. +359 2 68 9211, Fax. +359 2 68 9102

**Canada:** PHILIPS SEMICONDUCTORS/COMPONENTS,  
Tel. +1 800 234 7381, Fax. +1 800 943 0087

**China/Hong Kong:** 501 Hong Kong Industrial Technology Centre,  
72 Tat Chee Avenue, Kowloon Tong, HONG KONG,  
Tel. +852 2319 7888, Fax. +852 2319 7700

**Colombia:** see South America

**Czech Republic:** see Austria

**Denmark:** Sydhavnsgade 23, 1780 COPENHAGEN V,  
Tel. +45 33 29 3333, Fax. +45 33 29 3905

**Finland:** Sinikalliontie 3, FIN-02630 ESPOO,  
Tel. +358 9 615 800, Fax. +358 9 6158 0920

**France:** 51 Rue Carnot, BP317, 92156 SURESNES Cedex,  
Tel. +33 1 4099 6161, Fax. +33 1 4099 6427

**Germany:** Hammerbrookstraße 69, D-20097 HAMBURG,  
Tel. +49 40 2353 60, Fax. +49 40 2353 6300

**Hungary:** see Austria

**India:** Philips INDIA Ltd, Band Box Building, 2nd floor,  
254-D, Dr. Annie Besant Road, Worli, MUMBAI 400 025,  
Tel. +91 22 493 8541, Fax. +91 22 493 0966

**Indonesia:** PT Philips Development Corporation, Semiconductors Division,  
Gedung Philips, Jl. Buncit Raya Kav.99-100, JAKARTA 12510,  
Tel. +62 21 794 0040 ext. 2501, Fax. +62 21 794 0080

**Ireland:** Newstead, Clonskeagh, DUBLIN 14,  
Tel. +353 1 7640 000, Fax. +353 1 7640 200

**Israel:** RAPAC Electronics, 7 Kehilat Saloniki St, PO Box 18053,  
TEL AVIV 61180, Tel. +972 3 645 0444, Fax. +972 3 649 1007

**Italy:** PHILIPS SEMICONDUCTORS, Via Casati, 23 - 20052 MONZA (MI),  
Tel. +39 039 203 6838, Fax +39 039 203 6800

**Japan:** Philips Bldg 13-37, Kohnan 2-chome, Minato-ku,  
TOKYO 108-8507, Tel. +81 3 3740 5130, Fax. +81 3 3740 5057

**Korea:** Philips House, 260-199 Itaewon-dong, Yongsan-ku, SEOUL,  
Tel. +82 2 709 1412, Fax. +82 2 709 1415

**Malaysia:** No. 76 Jalan Universiti, 46200 PETALING JAYA, SELANGOR,  
Tel. +60 3 750 5214, Fax. +60 3 757 4880

**Mexico:** 5900 Gateway East, Suite 200, EL PASO, TEXAS 79905,  
Tel. +9-5 800 234 7381, Fax +9-5 800 943 0087

**Middle East:** see Italy

**Netherlands:** Postbus 90050, 5600 PB EINDHOVEN, Bldg. VB,  
Tel. +31 40 27 82785, Fax. +31 40 27 88399

**New Zealand:** 2 Wagener Place, C.P.O. Box 1041, AUCKLAND,  
Tel. +64 9 849 4160, Fax. +64 9 849 7811

**Norway:** Box 1, Manglerud 0612, OSLO,  
Tel. +47 22 74 8000, Fax. +47 22 74 8341

**Pakistan:** see Singapore

**Philippines:** Philips Semiconductors Philippines Inc.,  
106 Valero St. Salcedo Village, P.O. Box 2108 MCC, MAKATI,  
Metro MANILA, Tel. +63 2 816 6380, Fax. +63 2 817 3474

**Poland:** Al.Jerozolimskie 195 B, 02-222 WARSAW,  
Tel. +48 22 5710 000, Fax. +48 22 5710 001

**Portugal:** see Spain

**Romania:** see Italy

**Russia:** Philips Russia, Ul. Usatcheva 35A, 119048 MOSCOW,  
Tel. +7 095 755 6918, Fax. +7 095 755 6919

**Singapore:** Lorong 1, Toa Payoh, SINGAPORE 319762,  
Tel. +65 350 2538, Fax. +65 251 6500

**Slovakia:** see Austria

**Slovenia:** see Italy

**South Africa:** S.A. PHILIPS Pty Ltd., 195-215 Main Road Martindale,  
2092 JOHANNESBURG, P.O. Box 58088 Newville 2114,  
Tel. +27 11 471 5401, Fax. +27 11 471 5398

**South America:** Al. Vicente Pinzon, 173, 6th floor,  
04547-130 SÃO PAULO, SP, Brazil,  
Tel. +55 11 821 2333, Fax. +55 11 821 2382

**Spain:** Balmes 22, 08007 BARCELONA,  
Tel. +34 93 301 6312, Fax. +34 93 301 4107

**Sweden:** Kottbygatan 7, Akalla, S-16485 STOCKHOLM,  
Tel. +46 8 5985 2000, Fax. +46 8 5985 2745

**Switzerland:** Allmendstrasse 140, CH-8027 ZÜRICH,  
Tel. +41 1 488 2741 Fax. +41 1 488 3263

**Taiwan:** Philips Semiconductors, 6F, No. 96, Chien Kuo N. Rd., Sec. 1,  
TAIPEI, Taiwan Tel. +886 2 2134 2886, Fax. +886 2 2134 2874

**Thailand:** PHILIPS ELECTRONICS (THAILAND) Ltd.,  
209/2 Sanpavuth-Bangna Road Prakanong, BANGKOK 10260,  
Tel. +66 2 745 4090, Fax. +66 2 398 0793

**Turkey:** Yukari Dudullu, Org. San. Blg., 2.Cad. Nr. 28 81260 Umraniye,  
ISTANBUL, Tel. +90 216 522 1500, Fax. +90 216 522 1813

**Ukraine:** PHILIPS UKRAINE, 4 Patrice Lumumba str., Building B, Floor 7,  
252042 KIEV, Tel. +380 44 264 2776, Fax. +380 44 268 0461

**United Kingdom:** Philips Semiconductors Ltd., 276 Bath Road, Hayes,  
MIDDLESEX UB3 5BX, Tel. +44 208 730 5000, Fax. +44 208 754 8421

**United States:** 811 East Arques Avenue, SUNNYVALE, CA 94088-3409,  
Tel. +1 800 234 7381, Fax. +1 800 943 0087

**Uruguay:** see South America

**Vietnam:** see Singapore

**Yugoslavia:** PHILIPS, Trg N. Pasica 5/v, 11000 BEOGRAD,  
Tel. +381 11 3341 299, Fax.+381 11 3342 553

**For all other countries apply to:** Philips Semiconductors,  
International Marketing & Sales Communications, Building BE-p, P.O. Box 218,  
5600 MD EINDHOVEN, The Netherlands, Fax. +31 40 27 24825

**Internet:** <http://www.semiconductors.philips.com>

© Philips Electronics N.V. 2000

SCA 69

All rights are reserved. Reproduction in whole or in part is prohibited without the prior written consent of the copyright owner.

The information presented in this document does not form part of any quotation or contract, is believed to be accurate and reliable and may be changed without notice. No liability will be accepted by the publisher for any consequence of its use. Publication thereof does not convey nor imply any license under patent- or other industrial or intellectual property rights.

Printed in The Netherlands

613524/03/pp16

Date of release: 2000 May 08

Document order number: 9397 750 07006

*Let's make things better.*

**Philips**  
Semiconductors



**PHILIPS**



LittleDiode supplies new, hard to find or obsolete electronic components and semiconductors all over the world.

With over two million different components listed you are sure to find the part you need.

Feel free to visit us today at our online store:

[LittleDiode.com](http://LittleDiode.com)

Looking forward to providing you with the best possible service.