

DATA SHEET

BLW80 UHF power transistor

Product specification

March 1993

UHF power transistor

BLW80

DESCRIPTION

N-P-N silicon planar epitaxial transistor intended for transmitting applications in class-A, B or C in the u.h.f. and v.h.f. range for nominal supply voltages up to 13,5 V.

The resistance stabilization of the transistor provides protection against device damage at severe load mismatch conditions.

The transistor is housed in a 1/4" capstan envelope with a ceramic cap.

QUICK REFERENCE DATA

R.F. performance up to $T_h = 25\text{ }^\circ\text{C}$ in an unneutralized common-emitter class-circuit.

MODE OF OPERATION	V_{CE} V	f MHz	P_L W	G_p dB	η %	\bar{z}_i Ω	\bar{Y}_L mS
c.w.	12,5	470	4	> 8,0	> 60	2,1 + j2,3	57 - j56
c.w.	12,5	175	4	typ. 15,0	typ. 60	2,0 - j2,2	51 - j48

PIN CONFIGURATION

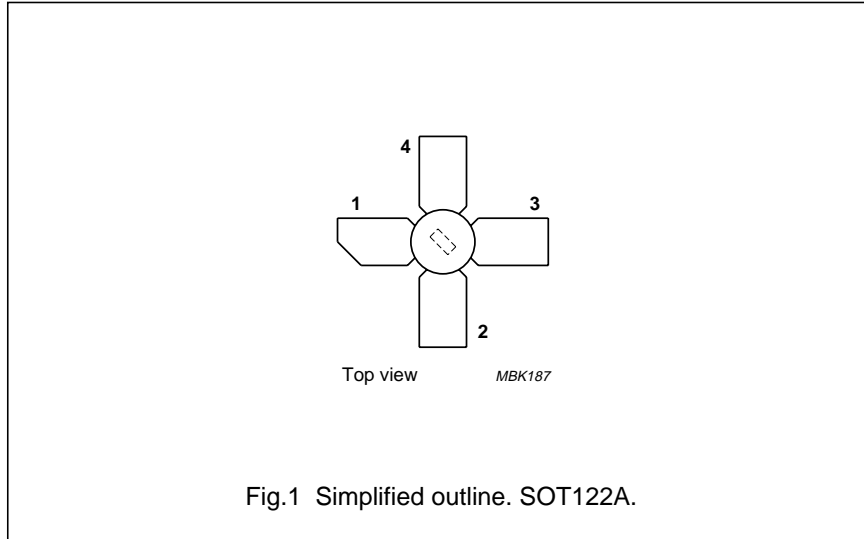

PINNING - SOT122A.

PIN	DESCRIPTION
1	collector
2	emitter
3	base
4	emitter

PRODUCT SAFETY This device incorporates beryllium oxide, the dust of which is toxic. The device is entirely safe provided that the BeO disc is not damaged.

UHF power transistor

BLW80

RATINGS

Limiting values in accordance with the Absolute Maximum System (IEC 134)

Collector-emitter voltage ($V_{BE} = 0$)

peak value

V_{CESM} max 36 V

Collector-emitter voltage (open base)

V_{CEO} max 17 V

Emitter-base voltage (open collector)

V_{EBO} max 4 V

Collector current (d.c.)

I_C max 1 A

Collector current (peak value); $f > 1$ MHz

I_{CM} max 3 A

Total power dissipation (d.c. and r.f.) up to $T_{mb} = 25$ °C

P_{tot} max 17 W

Storage temperature

T_{stg} -65 to +150 °C

Operating junction temperature

T_j max 200 °C

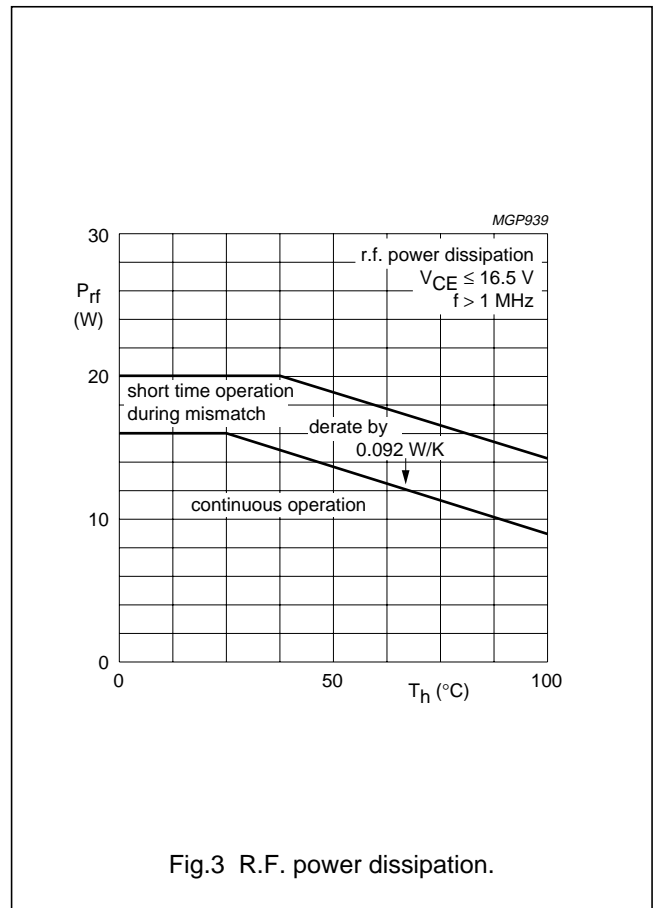
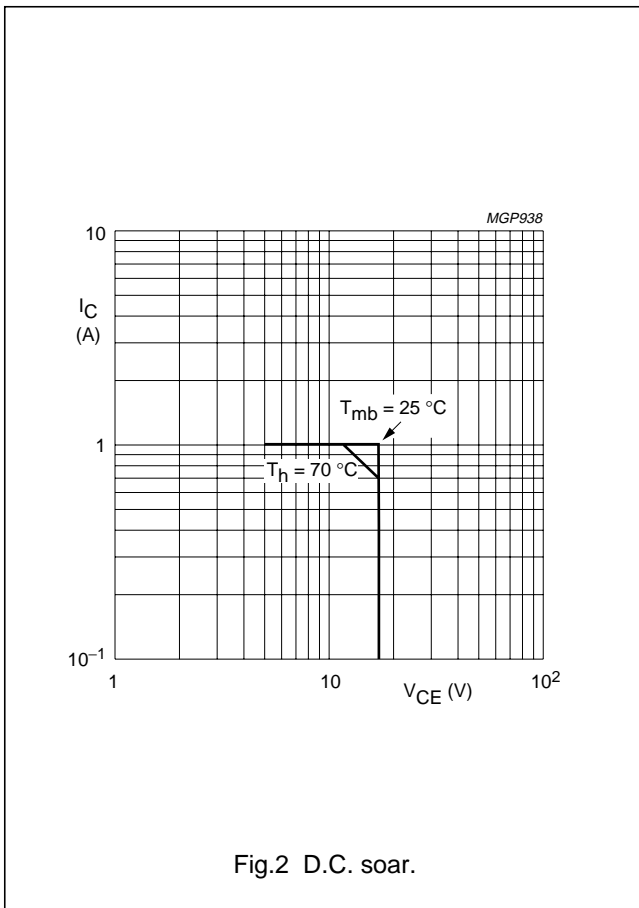

THERMAL RESISTANCE

From junction to mounting base

$R_{th\ j-mb}$ = 10,3 K/W

From mounting base to heatsink

$R_{th\ mb-h}$ = 0,6 K/W

UHF power transistor

BLW80

CHARACTERISTICS $T_j = 25\text{ }^\circ\text{C}$ **Breakdown voltages**

Collector-emitter voltage

 $V_{BE} = 0; I_C = 10\text{ mA}$ $V_{(BR)CES} > 36\text{ V}$

Collector-emitter voltage

open base; $I_C = 50\text{ mA}$ $V_{(BR)CEO} > 17\text{ V}$

Emitter-base voltage

open collector; $I_E = 4\text{ mA}$ $V_{(BR)EBO} > 4\text{ V}$ **Collector cut-off current** $V_{BE} = 0; V_{CE} = 17\text{ V}$ $I_{CES} < 4\text{ mA}$ **D.C. current gain ⁽¹⁾** $I_C = 0,5\text{ A}; V_{CE} = 5\text{ V}$ $h_{FE} > 10$
typ 35**Collector-emitter saturation voltage ⁽¹⁾** $I_C = 1,5\text{ A}; I_B = 0,3\text{ A}$ V_{CEsat} typ 0,75 V**Transition frequency at $f = 500\text{ MHz}$ ⁽¹⁾** $I_C = 0,5\text{ A}; V_{CE} = 12,5\text{ V}$ f_T typ 1,75 GHz $I_C = 1,5\text{ A}; V_{CE} = 12,5\text{ V}$ f_T typ 1,25 GHz**Collector capacitance at $f = 1\text{ MHz}$** $I_E = I_e = 0; V_{CB} = 12,5\text{ V}$ C_c typ 14 pF**Feedback capacitance at $f = 1\text{ MHz}$** $I_C = 40\text{ mA}; V_{CE} = 12,5\text{ V}$ C_{re} typ 7,1 pF**Collector-stud capacitance** C_{cs} typ 1,2 pF**Note**1. Measured under pulse conditions: $t_p \leq 200\text{ }\mu\text{s}$; $\delta \leq 0,02$.

UHF power transistor

BLW80

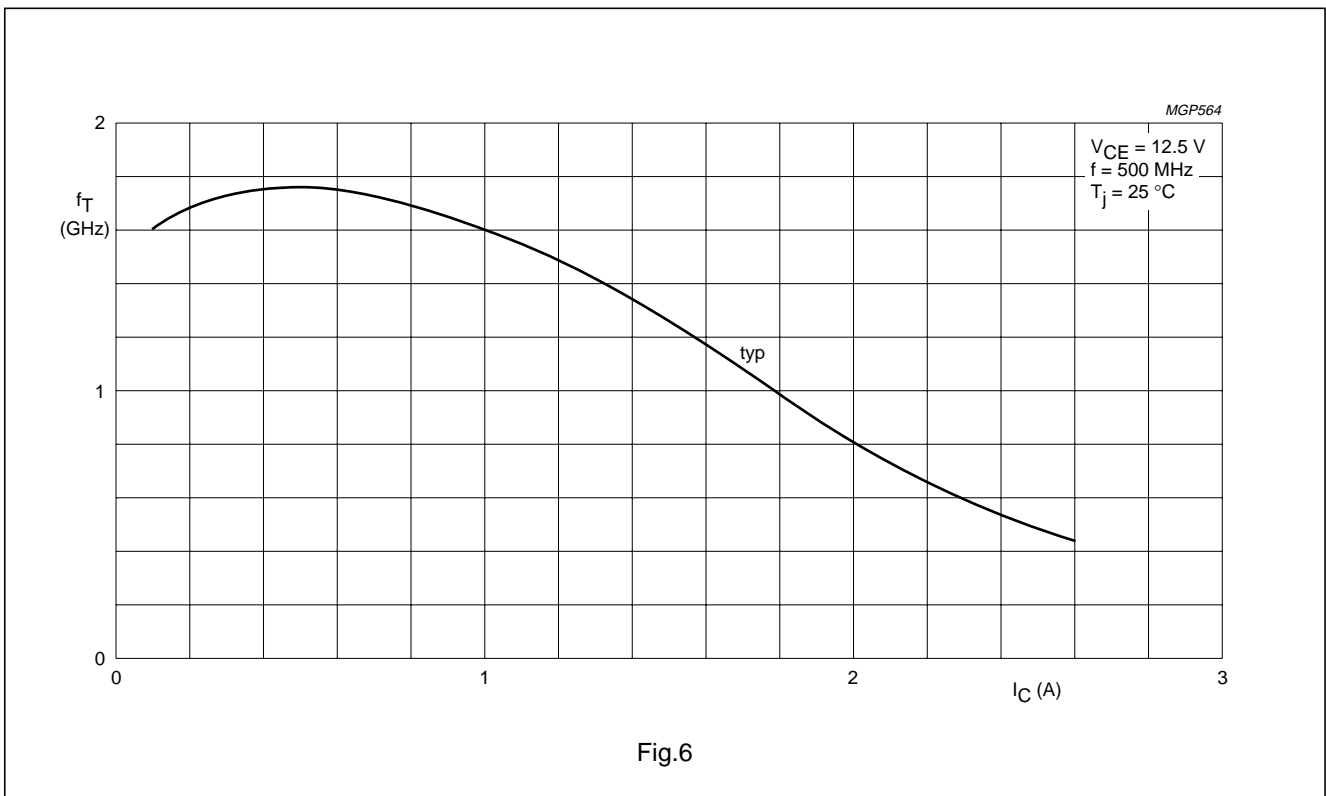
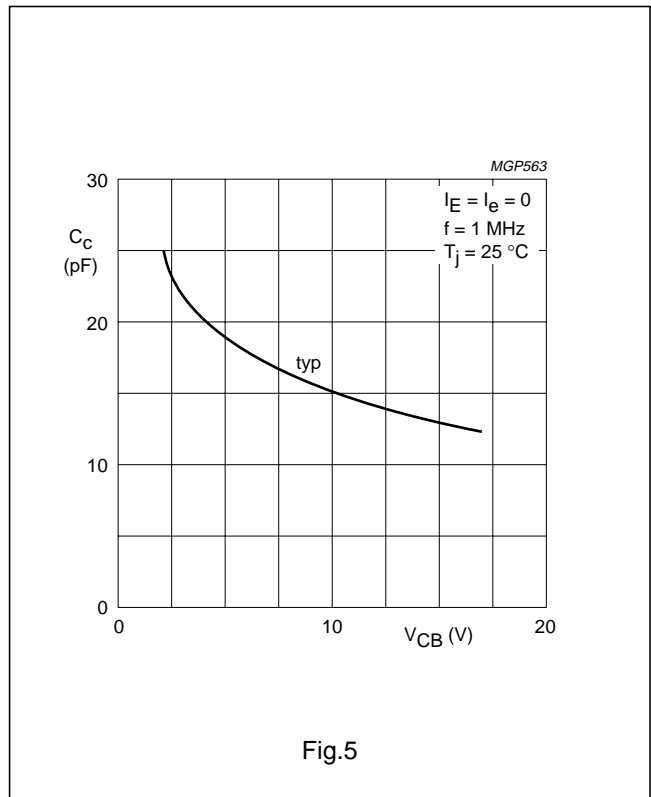
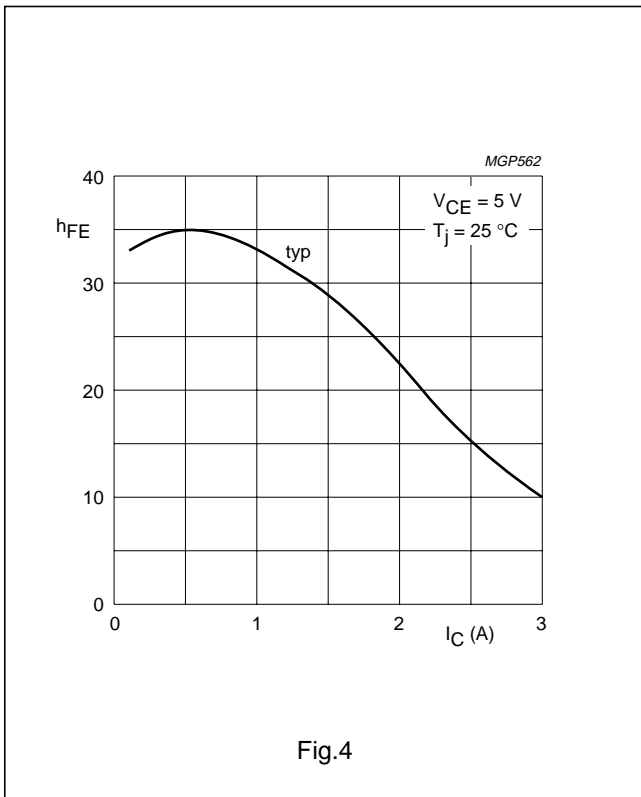

UHF power transistor

BLW80

APPLICATION INFORMATION

R.F. performance in c.w. operation (unneutralized common-emitter class-B circuit)

 $T_h = 25\text{ }^\circ\text{C}$

f (MHz)	V_{CE} (V)	P_L (W)	P_S (W)	G_p (dB)	I_C (A)	η (%)	\bar{z}_i (Ω)	\bar{Y}_L (mS)
470	12,5	4	< 0,63 >	8,0	< 0,53 >	> 60	$2,1 + j2,3$	$57 - j56$
470	13,5	4	–	typ 9,5	–	typ 65	–	–
175	12,5	4	–	typ 15,0	–	typ 60	$2,0 - j2,2$	$51 - j48$

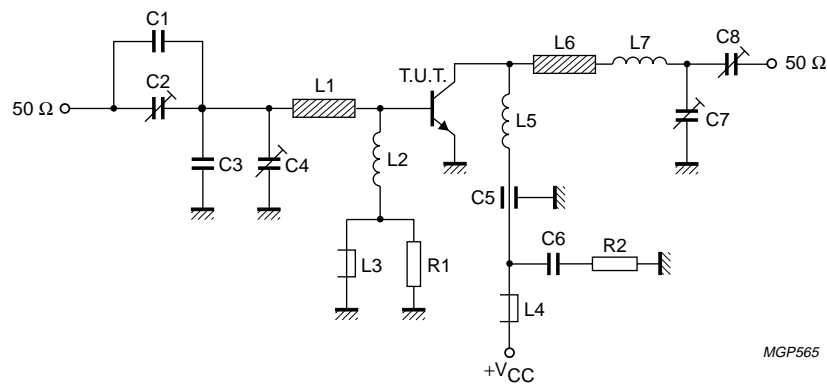
Fig.7 Class-B test circuit at $f = 470\text{ MHz}$.

List of components:

- C1 = 2,2 pF ($\pm 0,25\text{ pF}$) ceramic capacitor
- C2 = C7 = C8 = 1,4 to 5,5 pF film dielectric trimmer (cat. no. 2222 809 09001)
- C3 = 5,6 pF ($\pm 0,25\text{ pF}$) ceramic capacitor
- C4 = 2 to 9 pF film dielectric trimmer (cat. no. 2222 809 09002)
- C5 = 100 pF ceramic feed-through capacitor
- C6 = 100 nF polyester capacitor
- L1 = stripline (22,5 mm \times 6,0 mm)
- L2 = 13 turns closely wound enamelled Cu wire (0,5 mm); int. dia. 4 mm; leads 2 \times 5 mm
- L3 = L4 = Ferroxcube wide-band h.f. choke, grade 3B (cat. no. 4312 020 36640)
- L5 = 51 nH; 3,5 turns Cu wire (1 mm); int. dia. 6 mm; coil length 7 mm; leads 2 \times 5 mm
- L6 = stripline (10,0 mm \times 6,0 mm)
- L7 = 15 nH; 1 turn Cu wire (1 mm); int. dia. 5 mm; leads 2 \times 5 mm
- L1 and L6 are striplines on a double Cu-clad printed-circuit board with PTFE fibre-glass dielectric ($\epsilon_r = 2,74$); thickness 1/16".
- R1 = R2 = 10 Ω ($\pm 5\%$) carbon resistor

Component layout and printed-circuit board for 470 MHz test circuit (Fig.8).

UHF power transistor

BLW80

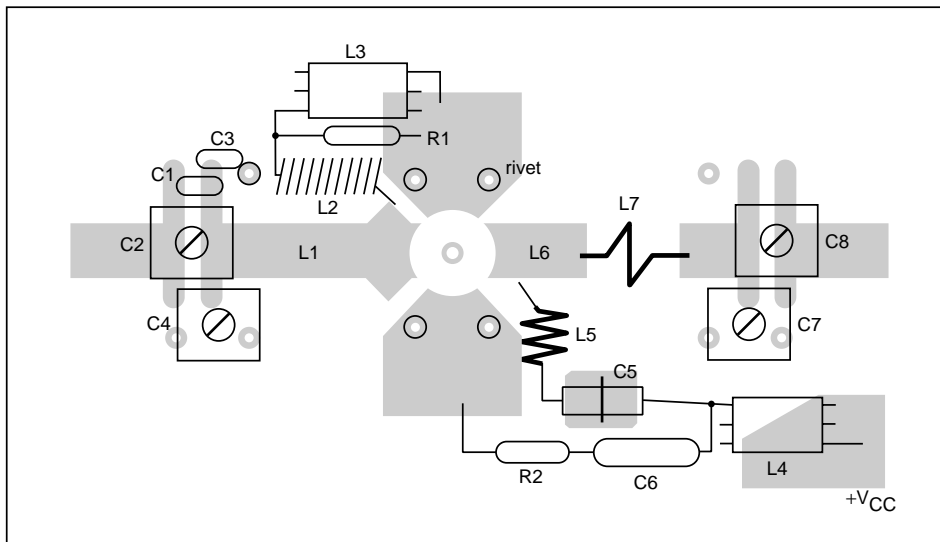
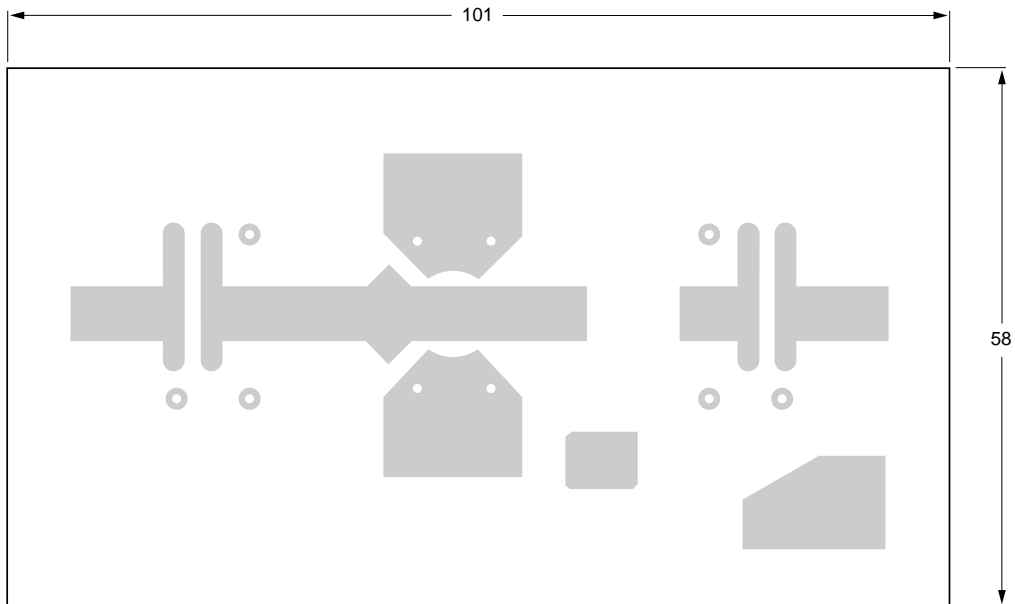

MGP566

The circuit and the components are situated on one side of the PTFE fibre-glass board, the other side being fully metallized to serve as earth. Earth connections are made by means of hollow rivets.

Fig.8 Component layout and printed-circuit board for 470 MHz test circuit.

UHF power transistor

BLW80

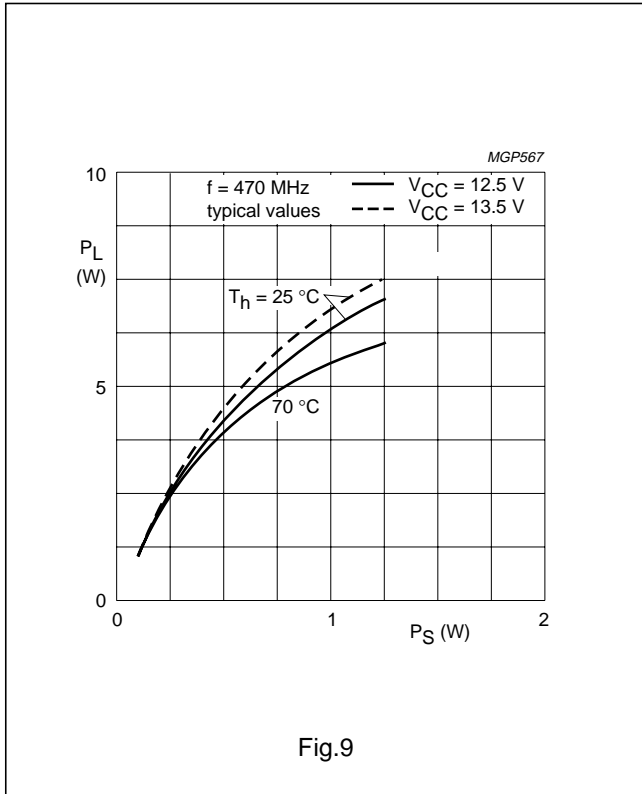

Fig.9

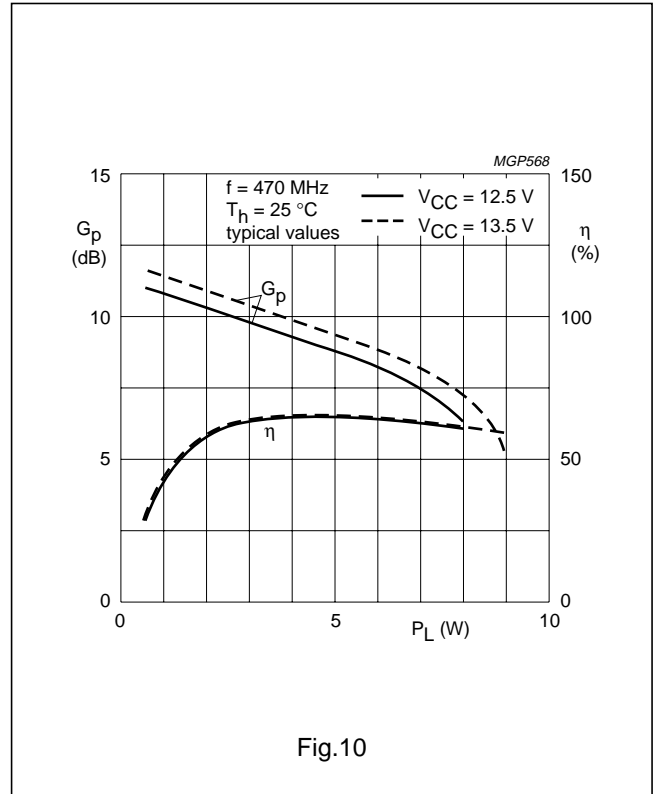

Fig.10

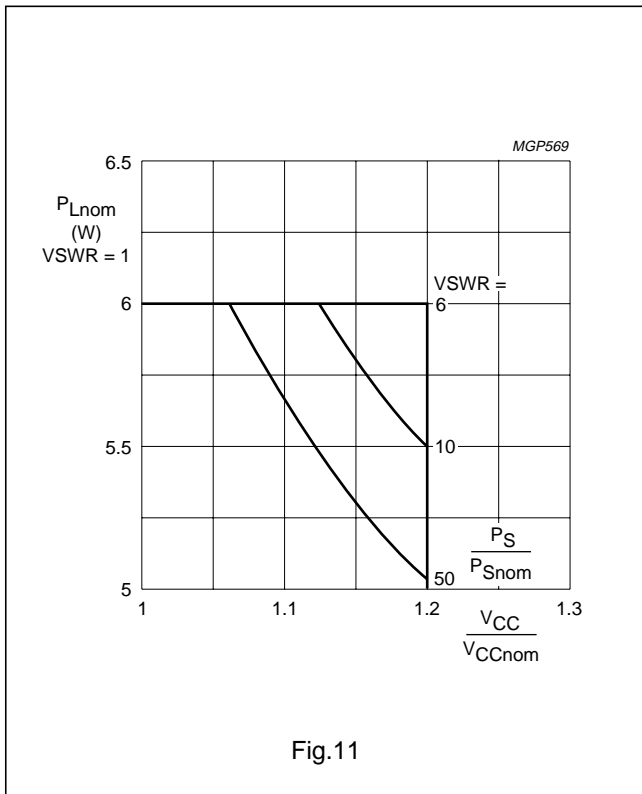

Fig.11

Conditions for R.F. SOAR

f = 470 MHz
 Th = 70 °C
 Rth mb-h = 0,6 K/W
 VCCnom = 12,5 V or 13,5 V
 PS = PSnom at VCCnom and VSWR = 1 measured in the circuit of Fig.7.

The transistor has been developed for use with unstabilized supply voltages. As the output power and drive power increase with the supply voltage, the nominal output power must be derated in accordance with the graph for safe operation at supply voltages other than the nominal. The graph shows the permissible output power under nominal conditions (VSWR = 1), as a function of the expected supply over-voltage ratio, with VSWR as parameter.

The graph applies to the situation in which the drive (PS/PSnom) increases linearly with supply over-voltage ratio.

UHF power transistor

BLW80

OPERATING NOTE

Below 300 MHz a base-emitter resistor of 10 Ω is recommended to avoid oscillation. This resistor must be effective for r.f. only.

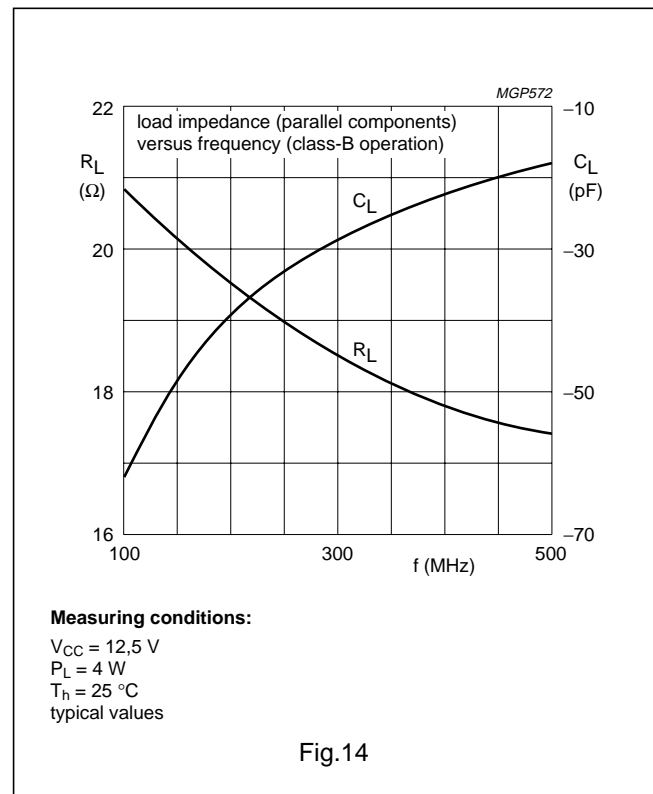
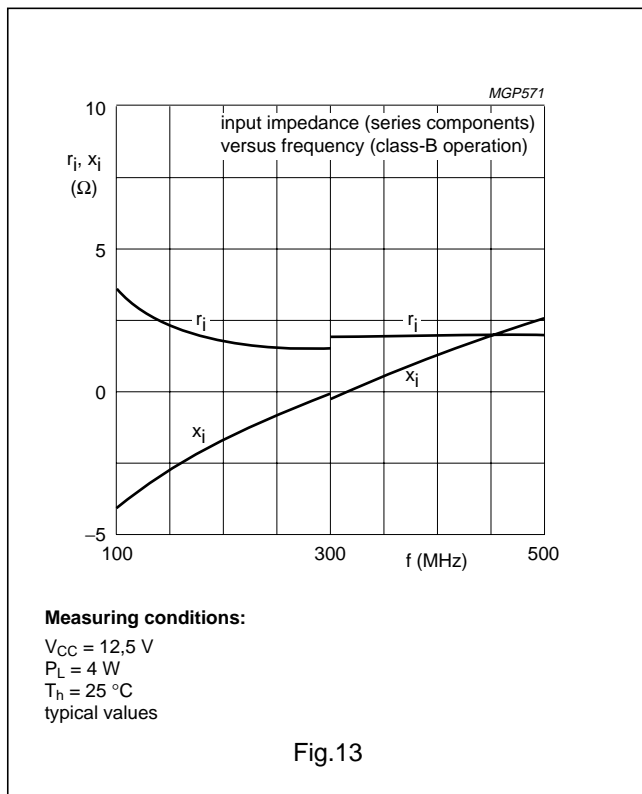
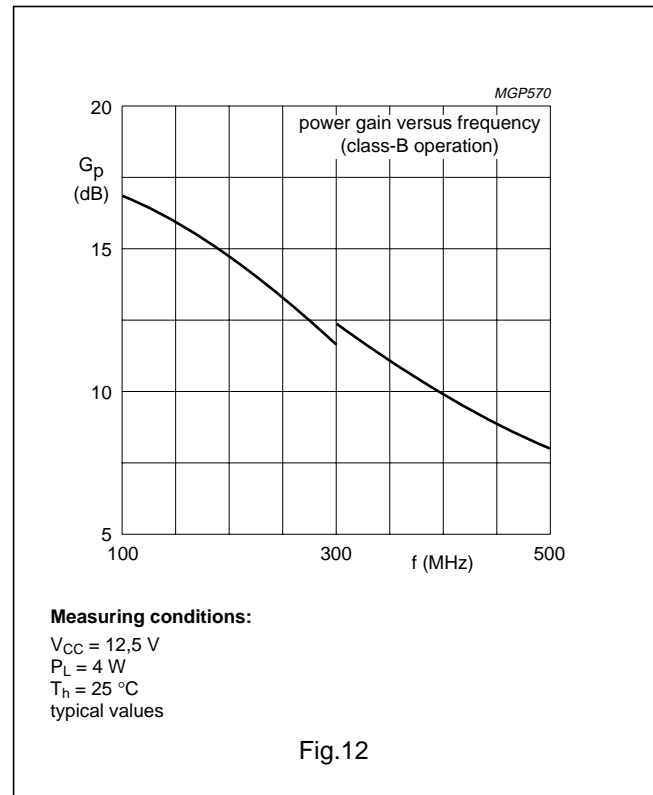

UHF power transistor

BLW80

PACKAGE OUTLINE

Studded ceramic package; 4 leads

SOT122A

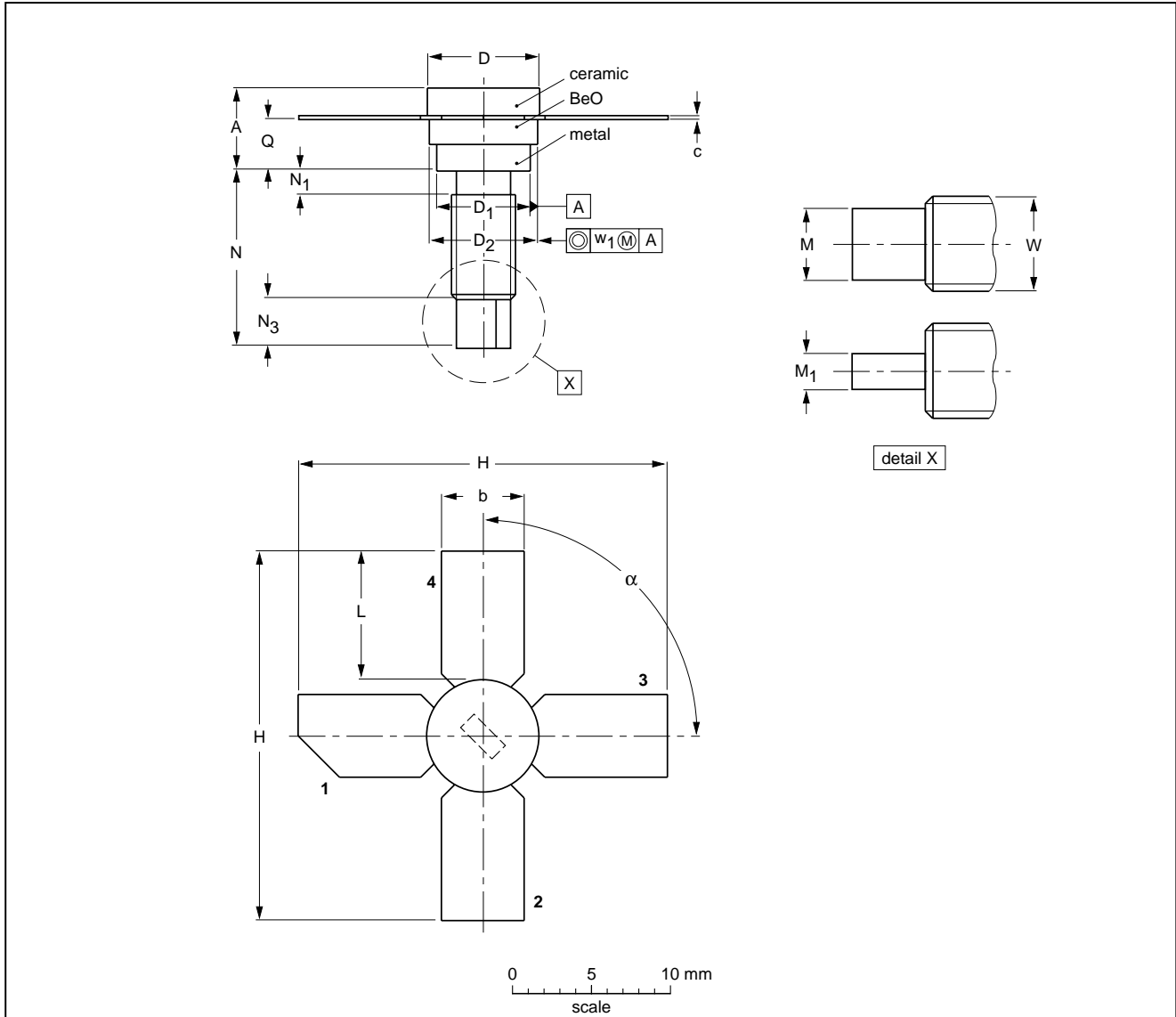

DIMENSIONS (millimetre dimensions are derived from the original inch dimensions)

UNIT	A	b	c	D	D ₁	D ₂	H	L	M ₁	M	N	N ₁ max.	N ₃	Q	W	w ₁	α
mm	5.97 4.74	5.85 5.58	0.18 0.14	7.50 7.23	6.48 6.22	7.24 6.93	27.56 25.78	9.91 9.14	3.18 2.66	1.66 1.39	11.82 11.04	1.02	3.86 2.92	3.38 2.74	8-32 UNC	0.381	90°

OUTLINE VERSION	REFERENCES				EUROPEAN PROJECTION	ISSUE DATE
	IEC	JEDEC	EIAJ			
SOT122A						97-04-18

UHF power transistor

BLW80

DEFINITIONS

Data Sheet Status	
Objective specification	This data sheet contains target or goal specifications for product development.
Preliminary specification	This data sheet contains preliminary data; supplementary data may be published later.
Product specification	This data sheet contains final product specifications.
Limiting values	
Limiting values given are in accordance with the Absolute Maximum Rating System (IEC 134). Stress above one or more of the limiting values may cause permanent damage to the device. These are stress ratings only and operation of the device at these or at any other conditions above those given in the Characteristics sections of the specification is not implied. Exposure to limiting values for extended periods may affect device reliability.	
Application information	
Where application information is given, it is advisory and does not form part of the specification.	

LIFE SUPPORT APPLICATIONS

These products are not designed for use in life support appliances, devices, or systems where malfunction of these products can reasonably be expected to result in personal injury. Philips customers using or selling these products for use in such applications do so at their own risk and agree to fully indemnify Philips for any damages resulting from such improper use or sale.



LittleDiode supplies new, hard to find or obsolete electronic components and semiconductors all over the world.

With over two million different components listed you are sure to find the part you need.

Feel free to visit us today at our online store:

LittleDiode.com

Looking forward to providing you with the best possible service.