



9,7 mm x 6,4 mm

SBS v1.1 COMPLIANT GAS GAUGE FOR USE WITH THE bq29312

FEATURES

- Provides Accurate Measurement of Available Charge in Li-Ion and Li-Polymer Batteries
- Supports the Smart Battery Specification (SBS) V1.1
- Integrated Time Base Removes Need for External Crystal with Optional Crystal input
- Works With the TI bq29312 Analog Front End (AFE) Protection IC to Provide Complete Pack Electronics for 7.2-V, 10.8-V or 14.4-V Battery Packs With Few External Components
- Based on a Powerful Low-Power RISC CPU Core With High-Performance Peripherals
- Integrated FLASH Memory Eliminates the Need for External Configuration EEPROM
- Uses 16-Bit Delta Sigma Converter for Accurate Voltage and Temperature Measurements
- Measures Charge Flow Using a High Resolution 16-Bit Integrating Converter
 - Better Than 0.65-nVh of Resolution
 - Self-Calibrating
 - Offset Error Less Than 1- μ V
- Programmable Cell Modeling for Maximum Battery Fuel Gauge Accuracy
- Drives 3-, 4-, or 5-Segment LED Display for Remaining Capacity Indication
- Available in a 38-Pin TSSOP (DBT) Package

APPLICATIONS

- Notebook PCs
- Medical and Test Equipment
- Portable Instrumentation

DESCRIPTION

The bq2084-V123 SBS-compliant gas gauge IC for battery pack or in-system installation maintains an accurate record of available charge in Li-ion or Li-polymer batteries. The bq2084-V123 monitors capacity and other critical parameters of the battery pack and reports the information to the system host controller over a serial communication bus. It is designed to work with the bq29312 analog front-end (AFE) protection IC to maximize functionality and safety and minimize component count and cost in smart battery circuits. Using information from the bq2084-V123, the host controller can manage remaining battery power to extend the system run time as much as possible.

The bq2084-V123 uses an integrating converter with continuous sampling for the measurement of battery charge and discharge currents. Optimized for coulomb counting in portable applications, the self-calibrating integrating converter has a resolution better than 0.65-nVh and an offset measurement error of less than 1- μ V (typical). For voltage and temperature reporting, the bq2084-V123 uses a 16-bit A-to-D converter. In conjunction with the bq29312, the onboard ADC also monitors the pack and individual cell voltages in a battery pack and allows the bq2084-V123 to generate the control signals necessary to implement the cell balancing and the required safety protection for Li-ion and Li-polymer battery chemistries.

The bq2084-V123 supports the Smart Battery Data (SBData) commands and charge-control functions. It communicates data using the System Management Bus (SMBus) 2-wire protocol. The data available include the battery's remaining capacity, temperature, voltage, current and remaining run-time predictions.

The bq2084-V123 provides LED drivers and a push-button input to depict remaining battery capacity from full to empty in 20%, 25%, or 33% increments with a 3-, 4-, or 5-segment display.



Please be aware that an important notice concerning availability, standard warranty, and use in critical applications of Texas Instruments semiconductor products and disclaimers thereto appears at the end of this data sheet.

bq2084-V123

SLUS619A – AUGUST 2004 – REVISED JANUARY 2005



These devices have limited built-in ESD protection. The leads should be shorted together or the device placed in conductive foam during storage or handling to prevent electrostatic damage to the MOS gates.

The bq2084-V123 contains 1k bytes of internal data flash memory, which store configuration information. The information includes nominal capacity and voltage, self-discharge rate, rate compensation factors, and other programmable cell-modeling factors used to accurately adjust remaining capacity for use-conditions based on time, rate, and temperature. The bq2084-V123 also automatically calibrates or learns the true battery capacity in the course of a discharge cycle from programmable near full to near empty levels.

The bq29312 analog front-end (AFE) protection IC is used to maximize functionality and safety and minimize component count and cost in smart battery circuits. The bq29312 AFE protection IC provides power to the bq2084-V123 from a 2, 3 or 4 series Li-ion cell stack, eliminating the need for an external regulator circuit.

ORDERING INFORMATION

T _A	PACKAGE
	38-PIN TSSOP (DBT)
-20°C to 85°C	bq2084DBT-V123 ⁽¹⁾

(1) The bq2084-V123 is available taped and reeled. Add an R suffix to the device type (e.g., bq2084DBTR-V123) to order tape and reel version.

ABSOLUTE MAXIMUM RATINGS

over operating free-air temperature range unless otherwise noted⁽¹⁾

	UNIT
Supply voltage range, V _{DD} relative to V _{SS} (see Note 2)	-0.3 V to 4.1 V
Open-drain I/O pins, V _(IOD) relative to V _{SS} (see Note 2)	-0.3 V to 6 V
Input voltage range to all other pins, V _I relative to V _{SS} (see Note 2)	-0.3 V to V _{DD} + 0.3 V
Operating free-air temperature range, T _A	-20°C to 85°C
Storage temperature range, T _{stg}	-65°C to 150°C

(1) Stresses beyond those listed under "absolute maximum ratings" may cause permanent damage to the device. These are stress ratings only, and functional operation of the device at these or any other conditions beyond those indicated under "recommended operating conditions" is not implied. Exposure to absolute-maximum-rated conditions for extended periods may affect device reliability.

(2) V_{SS} refers to the common node of V_(SSA), V_(SSD), and V_(SSP).

ELECTRICAL CHARACTERISTICS

$V_{DD} = 3.0\text{ V to }3.6\text{ V}$, $T_A = -20^\circ\text{C to }85^\circ\text{C}$ unless otherwise noted

PARAMETER		TEST CONDITIONS	MIN	TYP	MAX	UNIT
V_{DD}	Supply voltage	VDDA and VDDD	3.0	3.3	3.6	V
I_{DD}	Operating mode current	No flash programming or LEDs active		380		μA
$I_{(SLP)}$	Low-power storage mode current	Sleep mode		8		μA
V_{OL}	Output voltage low SMBC, SMBD, SDATA, SCLK, $\overline{\text{SAFE}}$, PU	$I_{OL} = 0.5\text{ mA}$			0.4	V
	LED1–LED5	$I_{OL} = 10\text{ mA}$			0.4	V
V_{IL}	Input voltage low SMBC, SMBD, SDATA, SCLK, EVENT, PU, PRES, PFIN		-0.3		0.8	V
	DISP		-0.3		0.8	V
V_{IH}	Input voltage high SMBC, SMBD, SDATA, SCLK, EVENT, PU, PRES, PFIN		2		6	V
	DISP		2	$V_{DD} + 0.3$		V
$V_{(A11)}$	Input voltage range VIN, TS		$V_{SS} - 0.3$		1.0	V
$V_{(A12)}$	Input voltage range SR1, SR2		$V_{SS} - 0.25$		0.25	V
$Z_{(A11)}$	Input impedance SR1, SR2	$-0.25\text{ V} - +0.25\text{ V}$	2.5			$\text{M}\Omega$
$Z_{(A12)}$	Input impedance VIN, TS	$0\text{ V} - 1.0\text{ V}$	8			$\text{M}\Omega$
POWER-ON RESET						
V_{IT+}	Negative-going voltage input		2.1	2.3	2.5	V
V_{hys}	Power-on reset hysteresis		50	125	200	mV

POWER ON RESET BEHAVIOR vs

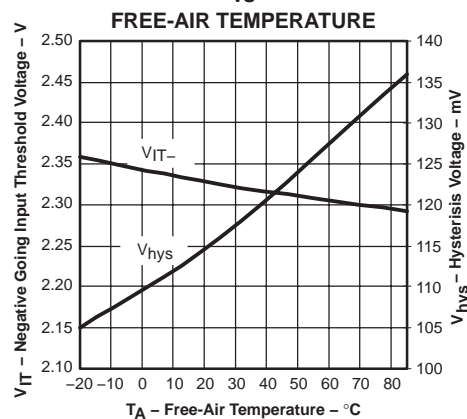

INTEGRATING ADC CHARACTERISTICS

$V_{DD} = 3.0\text{ V to }3.6\text{ V}$, $T_A = -20^\circ\text{C to }85^\circ\text{C}$ unless otherwise noted

PARAMETER	TEST CONDITIONS	MIN	TYP	MAX	UNIT	
$V_{(SR)}$	Input voltage range, $V_{(SR2)}$ and $V_{(SR1)}$	$V_{SR} = V_{(SR2)} - V_{(SR1)}$	-0.25		0.25	V
$V_{(SROS)}$	Input offset		1			μV
INL	Integral nonlinearity error	FAST = 0, $-0.1\text{ V to }0.8 \times V_{ref}$	0.004%	0.018%		

PLL SWITCHING CHARACTERISTICS

$V_{DD} = 3.0\text{ V to }3.6\text{ V}$, $T_A = -20^\circ\text{C to }85^\circ\text{C}$ unless otherwise noted

PARAMETER	TEST CONDITIONS	MIN	TYP	MAX	UNIT
$t_{(SP)}$	Start-up time (see Note 1)	$\pm 0.5\%$ frequency error	2	5	ms

(1) The frequency error is measured from the trimmed frequency of the internal system clock, which is 128 x oscillator frequency, nominally 4.194 MHz.

bq2084-V123

SLUS619A – AUGUST 2004 – REVISED JANUARY 2005

OSCILLATOR
 $V_{DD} = 3.0\text{ V to }3.6\text{ V}$, $T_A = -20^\circ\text{C to }85^\circ\text{C}$ (unless otherwise noted) (TYP: $V_{DD} = 3.3\text{ V}$, $T_A = 25^\circ\text{C}$)

PARAMETER		TEST CONDITIONS	MIN	TYP	MAX	UNIT
f _(eio)	Frequency error from 32.768 kHz	ROSC = 100k	-2%	0.5%	2%	
		XCK1 = 12 pF XTAL	-0.25%		0.25%	
f _(dio)	Frequency drift ⁽¹⁾	ROSC = 100k, T _A = 0°C to 50°C	-1%		1%	
f _(sio)	Start-up time (2)	ROSC = 100k			200	μs
f _(sxo)		XCK1 = 12 pF XTAL			250	ms

 (1) The frequency drift is measured from the trimmed frequency at $V_{DD} = 3.3\text{ V}$, $T_A = 25^\circ\text{C}$.

 (2) The start-up time is defined as the time it takes for the oscillator output frequency to be $\pm 1\%$
DATA FLASH MEMORY CHARACTERISTICS
 $V_{DD} = 3.0\text{ V to }3.6\text{ V}$, $T_A = -20^\circ\text{C to }85^\circ\text{C}$ unless otherwise noted

PARAMETER		TEST CONDITIONS	MIN	TYP	MAX	UNIT
t _{DR}	Data retention	See Note 1	10			Years
	Flash programming write-cycles	See Note 1	20k			Cycles
t _(WORDPROG)	Word programming time	See Note 1			2	ms
I _(DDPROG)	Flash-write supply current	See Note 1		8	12	mA

(1) Assured by design. Not production tested.

REGISTER BACKUP

PARAMETER		TEST CONDITIONS	MIN	TYP	MAX	UNIT
I _(RBI)	RBI data-retention input current	$V_{RBI} > 2.0\text{ V}$, $V_{DD} < V_{IT}$		10	100	nA
V _(RBI)	RBI data-retention voltage (see Note 1)		1.3			V

(1) Specified by design. Not production tested.

SMBus TIMING SPECIFICATIONS
 $V_{DD} = 3.0\text{ V to }3.6\text{ V}$, $T_A = -20^\circ\text{C to }85^\circ\text{C}$ unless otherwise noted

PARAMETER		TEST CONDITIONS	MIN	TYP	MAX	UNIT
f _(SMB)	SMBus operating frequency	Slave mode, SMBC 50% duty cycle	10		100	kHz
f _(MAS)	SMBus master clock frequency	Master mode, no clock low slave extend		51.2		kHz
t _(BUF)	Bus free time between start and stop		4.7			μs
T _(HD:STA)	Hold time after (repeated) start		4.0			μs
t _(SU:STA)	Repeated start setup time		4.7			μs
t _(SU:STO)	Stop setup time		4.0			μs
t _(HD:DAT)	Data hold time	Receive mode	0			ns
		Transmit mode	300			
t _(SU:DAT)	Data setup time		250			ns
t _(TIMEOUT)	Error signal/detect	See Note 1	25		35	ms
t _(LOW)	Clock low period		4.7			μs
t _(HIGH)	Clock high period	See Note 2	4.0		50	μs
t _(LOW:SEXT)	Cumulative clock low slave extend time	See Note 3			25	ms
t _(LOW:MEXT)	Cumulative clock low master extend time	See Note 4			10	ms
t _f	Clock/data fall time	(V _{ILMAX} - 0.15 V) to (V _{IHMIN} + 0.15 V)			300	ns
t _r	Clock/data rise time	0.9 V _{DD} to (V _{ILMAX} - 0.15 V)			1000	ns

 (1) The bq2084-V123 times out when any clock low exceeds t_(TIMEOUT)

 (2) t_(HIGH) Max. is minimum bus idle time. SMBC = 1 for t > 50 ms causes reset of any transaction involving bq2084-V123 that is in progress.

 (3) t_(LOW:SEXT) is the cumulative time a slave device is allowed to extend the clock cycles in one message from initial start to the stop.

 (4) t_(LOW:MEXT) is the cumulative time a master device is allowed to extend the clock cycles in one message from initial start to the stop.

SMBus TIMING DIAGRAMS

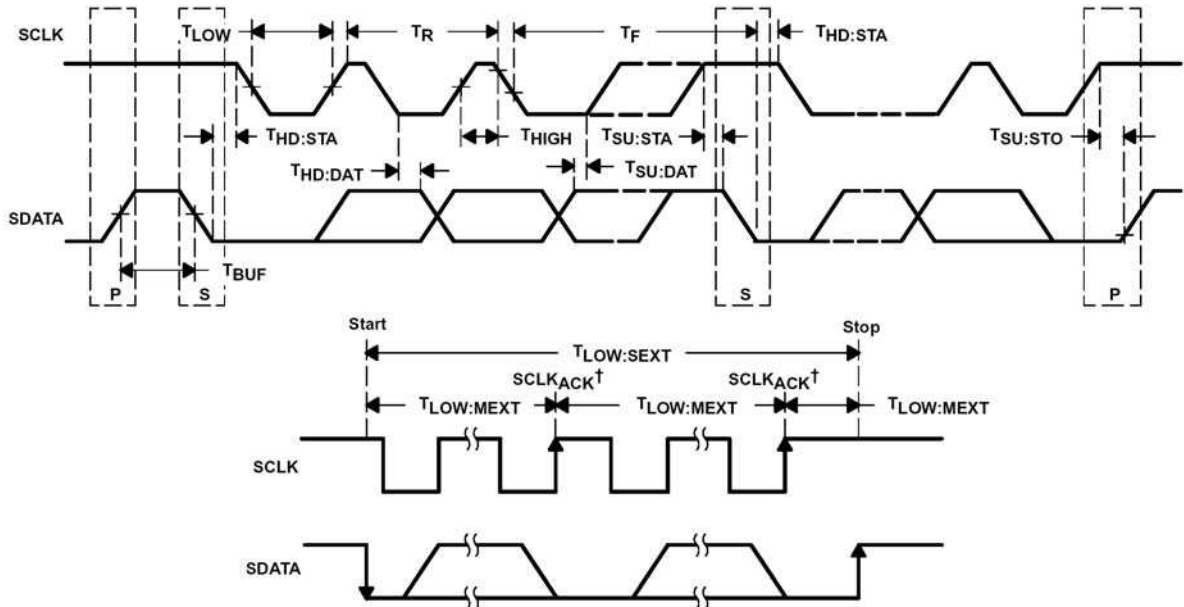

† SCLKACK is the acknowledge-related clock pulse generated by the master.

SYSTEM DIAGRAM

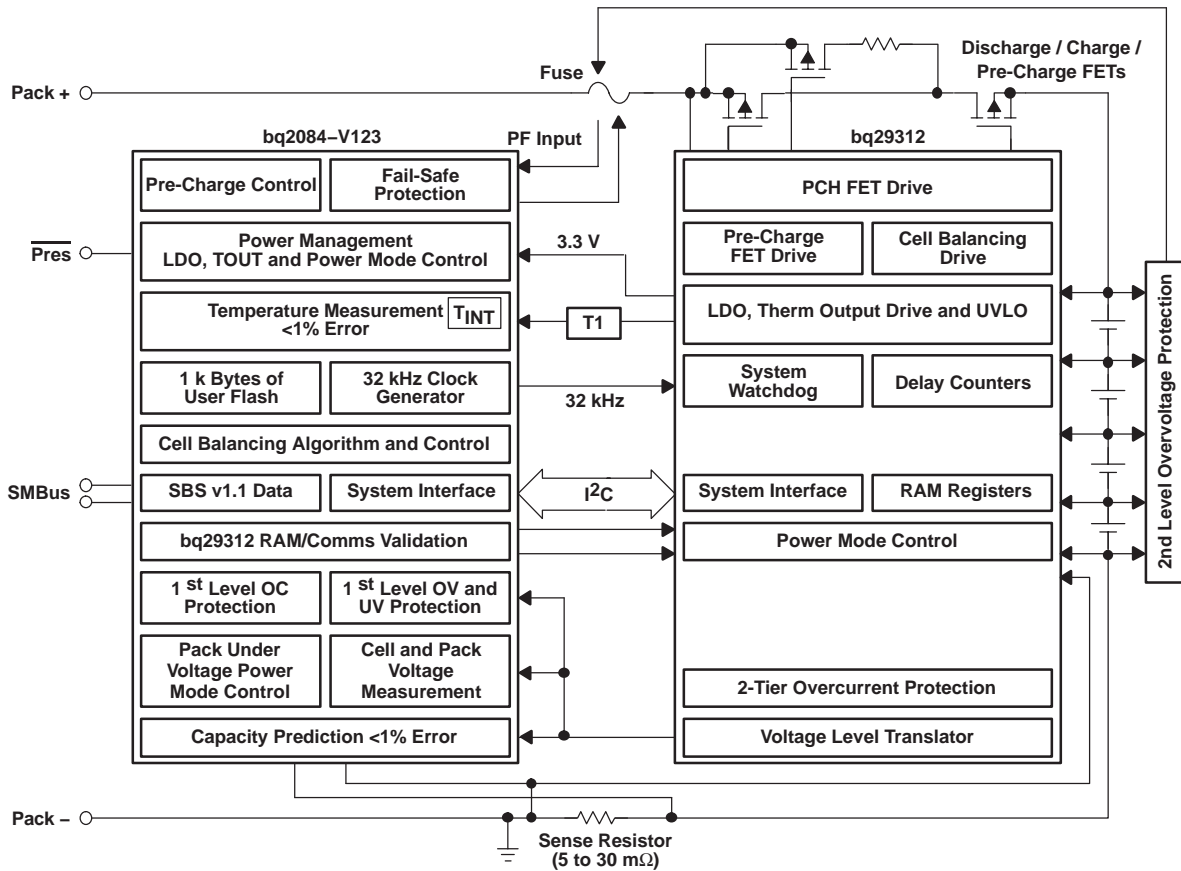

bq2084-V123

SLUS619A – AUGUST 2004 – REVISED JANUARY 2005

PIN ASSIGNMENTS

TSSOP (DBT)
(TOP VIEW)

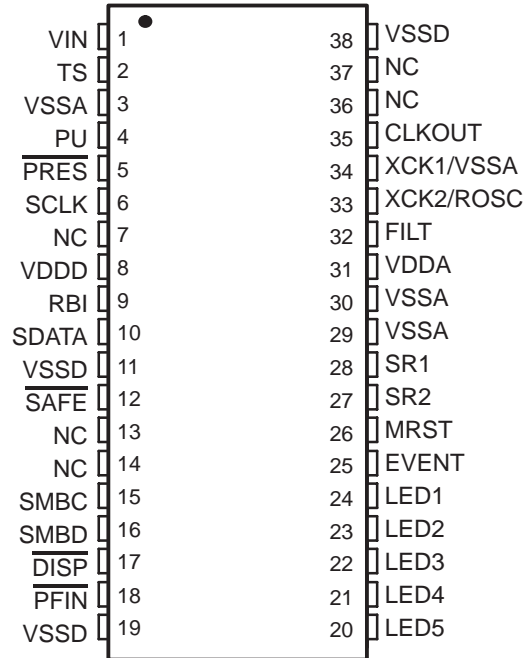

Terminal Functions

TERMINAL		I/O	DESCRIPTION
NAME	NO. TSSOP		
CLKOUT	35	I	32.768-kHz output to the bq29312
DISP	17	I	Display control for the LED drivers LED1 through LED5
FILT	32	I	Analog input connected to the external PLL filter
EVENT	25	I	Input from bq29312 XALERT output
LED1	24	O	LED display segments that each may drive an external LED
LED2	23	O	
LED3	22	O	
LED4	21	O	
LED5	20	O	
MRST	26	I	
NC	7, 13, 14, 36, 37	–	No connection
PFIN	18	I	Active low input to detect secondary protector output status
PRES	5	I	Active low input to sense system insertion
PU	4	O	Output to pull up the /PRES pin for detection
RBI	9	I	Register backup that provides backup potential to the bq2084-V123 data registers during periods of low operating voltage. RBI accepts a storage capacitor or a battery input.
SAFE	12	O	Active low output for additional level of safety protection; e.g., fuse blow.
SCLK	6	O	Communication clock to the bq29312
SDATA	10	I/O	Data transfer to and from bq29312
SMBC	15	I/O	SMBus clock open-drain bidirectional pin used to clock the data transfer to and from the bq2084-V123
SMBD	16	I/O	SMBus data open-drain bidirectional pin used to transfer address and data to and from the bq2084-V123
SR1	28	I	Connections for a small-value sense resistor to monitor the battery charge- and discharge-current flow
SR2	27	I	
TS	2	I	Thermistor voltage input connection to monitor temperature
VDDA	31	I	Positive supply for analog circuitry
VDDD	8	I	Positive supply for digital circuitry and I/O pins
VIN	1	I	Single cell voltage input from the bq29312
VSSA	3, 29, 30	I	Negative supply for analog circuitry
VSSD	11, 19, 38	I	Negative supply for digital circuitry
XCK1/VSSA	34	I	32.768-kHz crystal oscillator input pin or connected to VSSA if the internal oscillator is used
XCK2/ROSC	33	O	32.768-kHz crystal oscillator output pin or connected to a 100-kΩ, 50 ppm or better resistor if the internal oscillator is used

FUNCTIONAL DESCRIPTION

Oscillator Function

The oscillator of the bq2084-V123 can be set up for an internal or external operation. As the bq2084-V123 powers up it automatically attempts to start the internal oscillator but if a 100-k Ω resistor is not connected to ROSC (pin 33) then it attempts to start the oscillator using an external 32.768-kHz crystal. Either the 100-k Ω ROSC resistor OR the 12 pF 32.768-kHz crystal should be mounted, NOT both.

The performance of the internal oscillator is dependent on the tolerance of the 100-k Ω resistor connected between RSOC (pin 33) and VSSA (pin 34). It is recommended that this resistor be as close to the bq2084-V123 as possible and that it has a specification of $\pm 0.1\%$ tolerance and ± 50 ppm temperature drift or better. The 12-pF crystal, if used, should also be placed as close to the XCK1 (pin 34) and XCK2 (pin 33) pins as possible. The layout of the PCB around these pins and components is also an additional contributing factor to oscillator performance degradation.

The average temperature drift error of the oscillator function over a learning charge or discharge cycle introduces an equal capacity prediction error in a learned full charge capacity (FCC).

System Present Operation

When the bq2084-V123 detects that the battery is inserted into the system via a low state on the $\overline{\text{PRES}}$ input, the bq2084-V123 enters normal operating mode and sets the PRES bit in PackStatus(). The discharge FET will turn on within 250 ms of pack insertion. When the pack is removed from the system and the $\overline{\text{PRES}}$ input is high, then the bq2084-V123 enters the battery removed state and turns OFF the charge and discharge FETs, and enables the 0-V/precharging FET. If NR is Misc Config is set then the PRES input can be left floating as it is not used.

General Operation

The bq2084-V123 determines battery capacity by monitoring the amount of charge input or removed from a rechargeable battery. In addition to measuring charge and discharge, the bq2084-V123 measures individual cell voltages, pack voltage, temperature, and current, estimates battery self-discharge, and monitors the battery for low-voltage thresholds using features of the bq29312 AFE device.

The bq2084-V123 measures charge and discharge activity by monitoring the voltage across a small-value series sense resistor between the cell stack negative terminal and the negative terminal of the battery pack. The available battery charge is determined by monitoring this voltage and correcting the measurement for environmental and operating conditions.

The bq2084-V123 interfaces with the bq29312 to perform battery protection, cell balancing and voltage translation functions. The bq2084-V123 can accept any NTC thermistor (default is Semitec 103AT) for temperature measurement or can also be configured to use its internal temperature sensor. The bq2084-V123 uses temperature to monitor the battery pack and to compensate the self-discharge estimate.

Measurements

The bq2084-V123 uses an integrating sigma-delta analog-to-digital converter (ADC) for current measurement and a second sigma-delta ADC for individual cell and battery voltage and temperature measurement. The individual cell and pack voltages, Voltage(), Current(), AverageCurrent() and Temperature are updated every 1 s during normal operation.

Charge and Discharge Counting

The integrating ADC measures the charge and discharge flow of the battery by monitoring a small-value sense resistor between the SR1 and SR2 pins. The integrating ADC measures bipolar signals from -0.25 V to 0.25 V. The bq2084-V123 detects charge activity when $V_{\text{SR}} = V(\text{SR1}) - V(\text{SR2})$ is positive and discharge activity when $V_{\text{SR}} = V(\text{SR1}) - V(\text{SR2})$ is negative. The bq2084-V123 continuously integrates the signal over time, using an internal counter. The fundamental rate of the counter is 0.65 nVh. The bq2084-V123 updates RemainingCapacity() with the charge or discharge accumulated in this internal counter once every second.

Offset Calibration

The bq2084-V123 provides an auto-calibration feature to cancel the voltage offset error across SR1 and SR2 for maximum charge measurement accuracy. The bq2084-V123 performs auto-calibration when the SMBus lines stay low for a minimum of 20 s when it internally connects SR1 to SR2 and measures the internal offset. With this feature the bq2084-V123 is capable of automatic offset calibration down to <1 μ V.

Digital Filter

The bq2084-V123 does not measure charge or discharge counts below the digital filter threshold. The digital filter threshold is programmed in the *Digital Filter* DF 0x2c and should be set sufficiently high to prevent false signal detection with no charge or discharge flowing through the sense resistor.

Voltage

While monitoring SR1 and SR2 for charge and discharge currents, the bq2084-V123 monitors the individual series cell voltages through the bq29312. The bq2084-V123 configures the bq29312 to present the selected cell to the CELL pin of the bq29312, which should be connected to VIN of the bq2084-V123. The internal ADC of the bq2084-V123 then measures the voltage and scales it appropriately. The bq2084-V123 then reports the Voltage() and the individual cell voltages in VCELL1(), VCELL2(), VCELL3(), and VCELL4(). There is an additional SMBus command (0x45) that returns the measured ADC Reading of the PACK input to the AFE.

Current

The bq2084-V123 uses the SR1 and SR2 inputs to measure and calculate the battery charge and discharge current. This value is reported via the SBS command Current(). AverageCurrent() is implemented as a single pole IIR filter with a 14.5-s time constant.

Temperature

The TS input of the bq2084-V123 in conjunction with an NTC thermistor measures the battery temperature as shown in the schematic. The bq2084-V123 reports temperature via the SBS command Temperature().

The bq2084-V123 can also be configured to use its internal temperature sensor by setting the IT bit in *Misc Configuration* DF 0x2a-0x2b. Data flash locations DF 0xb5 through DF 0xc0 also have to be changed to prescribed values if the internal temperature sensor option is selected.

Table 1. Data Flash Settings for Internal or External Temperature Sensor

LABEL	LOCATION	INTERNAL TEMP SENSOR SETTING	EXTERNAL TEMP SENSOR SETTING (SEMITEC 103AT)
	DEC (HEX)	DEC (HEX)	DEC (HEX)
Misc. Config	42 (0x2a)	Bit 7 = 1	Bit 7 = 0
TS Const1 A3	164/5 (0xb5/6)	0 (0x0000)	-28285 (0x9183)
TS Const2 A2	166/7 (0xb7/8)	0 (0x0000)	20848 (0x5170)
TS Const3 A1	168/9 (0xb9/a)	-11136 (0xd480)	-7537 (0xe28f)
TS Const4 A0	170/1 (0xbb/c)	5734 (0x1666)	4012 (0x0fac)
Min Temp AD	172/3 (0xbd/e)	0 (0x0000)	0 (0x000)
Max Temp	174/5 (0xbf/c0)	5734 (0x1666)	4012 (0x0fac)

Gas Gauge Operation

General

The operational overview in Figure 1 illustrates the gas gauge operation of the bq2084-V123. Table 3 describes the bq2084-V123 registers.

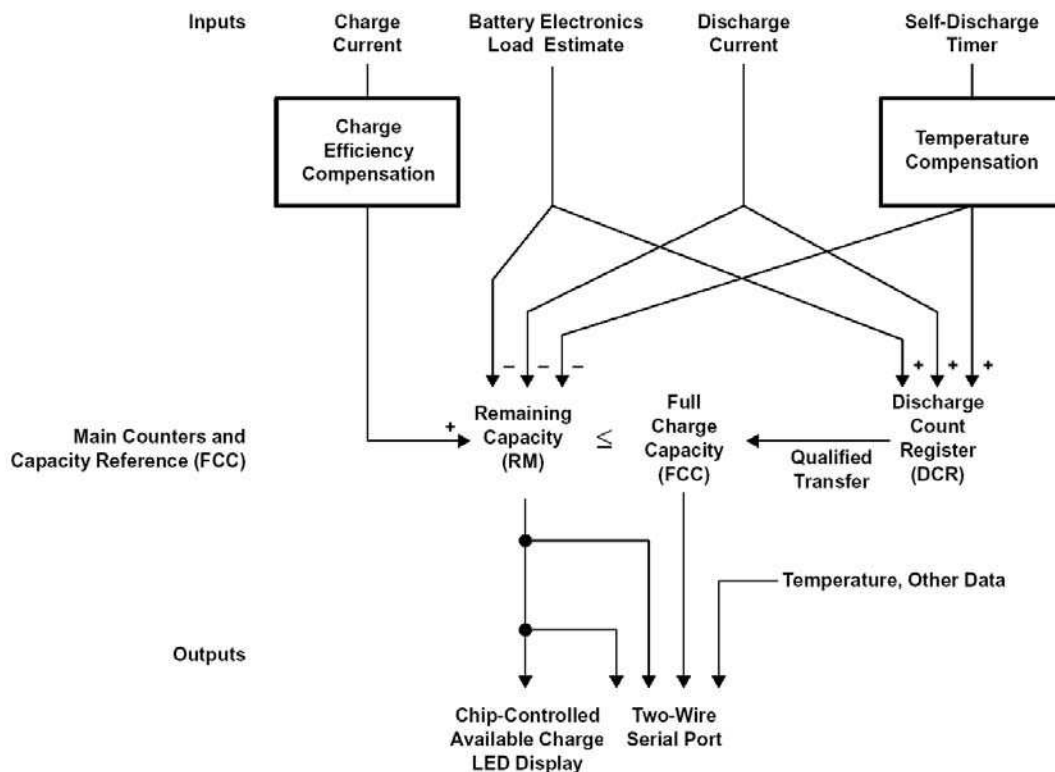

Figure 1. bq2084-V123 Gas Gauging Operational Overview

The bq2084-V123 accumulates a measure of charge and discharge currents and estimates self-discharge of the battery. The bq2084-V123 compensates the charge current measurement for temperature and state-of-charge of the battery. The bq2084-V123 also adjusts the self-discharge estimation based on temperature.

The main charge counter RemainingCapacity() (RM) represents the available capacity or energy in the battery at any given time. The bq2084-V123 adjusts RM for charge, self-discharge, and other compensation factors. The information in the RM register is accessible through the SMBus interface and is also represented through the LED display.

The FullChargeCapacity() (FCC) register represents the last measured learned full discharge of the battery. It is used as the battery full-charge reference for relative capacity indication. The bq2084-V123 updates FCC after the battery undergoes a qualified discharge from nearly full to a low battery level. FCC is accessible through the SMBus interface.

The Discharge Count Register (DCR) is a non-accessible register that tracks discharge of the battery. The bq2084-V123 uses the DCR register to update the FCC register if the battery undergoes a qualified discharge from nearly full to a low battery level. In this way, the bq2084-V123 learns the true discharge capacity of the battery under system use conditions.

Main Gas-Gauge Registers

RemainingCapacity() (RM)

RM represents the remaining capacity in the battery. The bq2084-V123 computes RM in units of either mAh or 10 mWh depending on the selected mode. See Battery Mode() (0x03) for units configuration. RM counts up during charge to a maximum value of FullChargeCapacity() (FCC) and down during discharge and self-discharge to a minimum of 0. In addition to charge and self-discharge compensation, the bq2084-V123 calibrates RM at three low-battery-voltage thresholds, EDV2, EDV1, and EDV0 and three programmable midrange thresholds VOC25, VOC50, and VOC75. This provides a voltage-based calibration to the RM counter.

DesignCapacity () (DC)

DC is the user-specified battery full capacity. It is calculated from *Pack Capacity* DF 0x32–0x33 and is represented in units of mAh or 10 mWh. It also represents the full-battery reference for the absolute display mode.

FullChargeCapacity() (FCC)

FCC is the last learned measured discharge capacity of the battery. It is represented in units of either mAh or 10 mWh, depending on the selected mode. On initialization, the bq2084-V123 sets FCC to the value stored in *Full Charge Capacity* DF 0x36–0x37. During subsequent discharges, the bq2084-V123 updates FCC with the last learned measured discharge capacity of the battery. The last learned measured discharge of the battery is based on the value in the Discharge Count Register (DCR) after a qualified discharge occurs. Once updated, the bq2084-V123 writes the new FCC value to data flash in mAh to *Full Charge Capacity*. FCC represents the full battery reference for the relative display mode, relative state of charge and AtRate() calculations.

Discharge Count Register (DCR)

The DCR register counts up during discharge, independent of RM. DCR counts discharge activity, battery load estimation, and self-discharge increments. The bq2084-V123 initializes DCR, at the beginning of a discharge, to FCC – RM when FCC – RM is within the programmed value in *Near Full* DF 0x30. The DCR initial value of FCC – RM is reduced by FCC/128 if SC = 1 (bit 5 in *Gauge Configuration*) and is not reduced if SC = 0. DCR stops counting when the battery voltage reaches the EDV2 threshold on discharge.

Capacity Learning (FCC Update) and Qualified Discharge

The bq2084-V123 updates FCC with an amount based on the value in DCR if a qualified discharge occurs. The new value for FCC equals the DCR value plus the programmable nearly full and low battery levels, according to the following equation:

$$\text{FCC (new)} = \text{DCR (final)} = \text{DCR (initial)} + \text{Measured Discharge to EDV2} + (\text{FCC} \times \text{Battery Low\%})$$

here *Battery Low %* = (value stored in DF 0x2f) ÷ 2.56

A qualified discharge occurs if the battery discharges from RM = FCC – *Near Full* to the EDV2 voltage threshold with the following conditions: *W*

- No more than 256 mAh of self-discharge or battery load estimation occurs during the discharge period
- The temperature does not drop below the low temperature threshold programmed in *Learning Low Temp* DF 0xac at the time when EDV2 is reached.
- The battery voltage reaches the EDV2 threshold during the discharge period and the voltage is greater than or equal to the EDV2 threshold minus 256 mV when the bq2084-V123 detected EDV2
- No midrange voltage correction occurs during the discharge period
- Current remains $\geq 3C/32$ when EDV2 or *Battery Low %* level is reached.
- No overload condition exists when EDV2 threshold is reached or if RM() has dropped to *Battery Low%* x FCC
- No valid charge activity occurs during the discharge period. A valid charge is defined as an uninterrupted charge of 10 mAh into the battery

The bq2084-V123 sets VDQ=1 in PackStatus() when qualified discharge begins. The bq2084-V123 sets VDQ=0 if any disqualifying condition occurs. FCC cannot be reduced by more than 256 mAh or increased by more than 512 mAh during any single update cycle. The bq2084-V123 saves the new FCC value to the data flash within 4 seconds of being updated.

End-of-Discharge Thresholds and Capacity Correction

The bq2084-V123 monitors the battery for three low-voltage thresholds, EDV0, EDV1, and EDV2. The EDV thresholds can be programmed for determination based on the overall pack voltage or an individual cell level. The EDVV bit in *Pack Configuration* DF 0x28 configures the bq2084-V123 for overall voltage or single-cell EDV thresholds. If programmed for single cell EDV determination, the bq2084-V123 determines EDV on the basis of the lowest single-cell voltage. Fixed EDV thresholds must be programmed in *EMF/EDV0* DF 0x95–0x96, *EDV C0 Factor/EDV1* DF 0x97–0x98 and *EDV R Factor/EDV2* DF 0x99–0x9a.

If the CEDV bit in *Gauge Configuration* DF 0x29 is set, automatic compensated EDVs are enabled and the bq2084-V123 computes the EDV0, EDV1, and EDV2 voltage thresholds based on the values in DF 0x95–0xa0 and the battery's current discharge rate and temperature. The bq2084-V123 disables EDV detection if Current() exceeds the *Overload Current* threshold programmed in DF 0x5b–DF 0x5c. The bq2084-V123 resumes EDV threshold detection after Current() drops below the *Overload Current* threshold. Any EDV threshold detected is reset after charge is detected and VDQ is cleared after 10 mAh of charge.

The bq2084-V123 uses the EDV thresholds to apply voltage-based corrections to the RM register according to Table 2.

Table 2. State of Charge Based on Low Battery Voltage

THRESHOLD	RELATIVE STATE OF CHARGE
EDV0	0%
EDV1	3%
EDV2	Battery Low %

The bq2084-V123 performs EDV-based RM adjustments with $\text{Current}(\) \geq C/32$. No EDV flags are set if current $< C/32$.

The bq2084-V123 adjusts RM as it detects each threshold. If the voltage threshold is reached before the corresponding capacity on discharge, the bq2084-V123 reduces RM to the appropriate amount as shown in Table 2.

If an RM % level is reached on discharge before the voltage reaches the corresponding threshold, then RM is held at that % level until the threshold is reached. RM is only held if VDQ = 1, indicating a valid learning cycle is in progress. If *Battery Low %* is set to zero, EDV1 and EDV0 corrections are disabled.

EDV Thresholds and Near-Full Programming

The bq2084-V123 uses the values stored in data flash for the EDV0, EDV1, and EDV2 values or calculates the three thresholds from a base value and the temperature, capacity, and rate adjustment factors stored in data flash. If EDV compensation is disabled, then EDV0, EDV1, and EDV2 are stored directly in mV in DF 0x95–0x96, DF 0x97–0x98, and DF 0x99–0x9a, respectively.

For capacity correction at EDV2, *Battery Low %* DF 0x2f can be set at a desired state-of-charge, STATEOFCHARGE%, in the range of 3–19%. Typical values for STATEOFCHARGE% are 5–7%, representing 5–7% capacity.

$$\text{Battery Low \%} = (\text{STATEOFCHARGE\%} \times 2.56)$$

The bq2084-V123 updates FCC if a qualified discharge occurs from a near-full threshold of FCC – *Near Full*, until EDV2 condition is reached. The desired near-full threshold window is programmed in *Near Full* in DF 0x30, 0x31 in mAh.

EDV Discharge Rate and Temperature Compensation Programming

If EDV compensation is enabled, the bq2084-V123 calculates battery voltage to determine EDV0, EDV1, and EDV2 thresholds as a function of battery capacity, temperature, and discharge load. The general equation for EDV0, EDV1, and EDV2 calculation is

$$\text{EDV}_{0,1,2} = n (\text{EMF} \bullet \text{FBL} - | \text{ILOAD} | \bullet \text{R0} \bullet \text{FTZ})$$

EMF is a no-load cell voltage higher than the highest cell EDV threshold computed. EMF is programmed in mV in *EMF/EDV1* DF 0x95–0x96.

ILOAD is the current discharge load magnitude.

n = the number of series cells

FBL is the factor that adjusts the EDV voltage for battery capacity and temperature to match the no-load characteristics of the battery.

$$FBL = f (C0, C + C1, T)$$

C (either 0%, 3%, or *Battery Low* % for EDV0, EDV1, and EDV2, respectively) and C0 are the capacity related EDV adjustment factors. C0 is programmed in *EDV C0 Factor/EDV1 DF* 0x97–98. C1 is the desired residual battery capacity remaining at EDV0 (RM = 0). The C1 factor is stored in *EDV C1 Factor DF* 0xa0.

T is the current temperature in °K.

R0 • FTZ represents the resistance of a cell as a function of temperature and capacity.

$$FTZ = f (R1 , T0, T, C + C1, TC)$$

R0 is the first order rate dependency factor stored in *EDV R0 Factor/EDV2 DF* 0x99–0x9a.

T is the current temperature; C is the battery capacity relating to EDV0, EDV1, and EDV2.

R1 adjusts the variation of impedance with battery capacity. R1 is programmed in *EDV R1 Rate Factor DF* 0x9d–0x9e.

T0 adjusts the variation of impedance with battery temperature. T0 is programmed in *EDV T0 Rate Factor DF* 0x9b–0x9c.

TC adjusts the variation of impedance for cold temperatures (T < 23°C). TC is programmed in *EDV TC DF* 0x9f.

Typical values for the EDV compensation factors, based on overall pack voltages for a Li-Ion 3s2p 18650 pack, are:

$$EMF = 11550/3$$

$$T0 = 4475$$

$$C0 = 235$$

$$C1 = 0$$

$$R0 = 5350/3$$

$$R1 = 250$$

$$TC = 3$$

Table 3. bq2084-V123 Register Functions

FUNCTION	COMMAND CODE	ACCESS	UNITS
ManufacturerAccess	0x00	Read/write	NA
RemainingCapacityAlarm	0x01	Read/write	mAh, 10 mWh
RemainingTimeAlarm	0x02	Read/write	minutes
BatteryMode	0x03	Read/write	NA
AtRate	0x04	Read/write	mA, 10 mW
AtRateTimeToFull	0x05	Read	minutes
AtRateTimeToEmpty	0x06	Read	minutes
AtRateOK	0x07	Read	Boolean
Temperature	0x08	Read	0.1°K
Voltage	0x09	Read	mV
Current	0x0a	Read	mA
AverageCurrent	0x0b	Read	mA
MaxError	0x0c	Read	percent
RelativeStateOfCharge	0x0d	Read	percent
AbsoluteStateOfCharge	0x0e	Read	percent
RemainingCapacity	0x0f	Read	mAh, 10 mWh
FullChargeCapacity	0x10	Read	mAh, 10 mWh
RunTimeToEmpty	0x11	Read	minutes
AverageTimeToEmpty	0x12	Read	minutes
AverageTimeToFull	0x13	Read	minutes
ChargingCurrent	0x14	Read	mA
ChargingVoltage	0x15	Read	mV
Battery Status	0x16	Read	NA
CycleCount	0x17	Read	cycles
DesignCapacity	0x18	Read	mAh, 10 mWh
DesignVoltage	0x19	Read	mV
SpecificationInfo	0x1a	Read	NA
ManufactureDate	0x1b	Read	NA
SerialNumber	0x1c	Read	integer
Reserved	0x1d–0x1f	0	0
ManufacturerName	0x20	Read	string
DeviceName	0x21	Read	string
DeviceChemistry	0x22	Read	string
ManufacturerData	0x23	Read	string
Pack status	0x2f (LSB)	Read	NA
Pack configuration	0x2f (MSB)	Read	NA
VCELL4	0x3c	Read	mV
VCELL3	0x3d	Read	mV
VCELL2	0x3e	Read	mV
VCELL1	0x3f	Read	mV
VPACK	0x45	Read	mV
AFEData	0x46	Read	hex

Self-Discharge

The bq2084-V123 estimates the self-discharge of the battery to maintain an accurate measure of the battery capacity during periods of inactivity. The bq2084-V123 makes self-discharge adjustments to RM every 1/4 s when awake and periodically (determined by *Sleep Timer* DF 0xfe) when in sleep mode. The self-discharge estimation rate for 25°C is doubled for each 10 degrees above 25°C or halved for each 10 degrees below 25°C. Table 4 shows the relation of the self-discharge estimation at a given temperature to the rate programmed for 25°C (Y% per day programmed in DF 0x2d).

Table 4. Self-Discharge for Rate Programmed

TEMPERATURE (°C)	SELF-DISCHARGE RATE
Temp < 10	1/4 Y% per day
10 ≤ Temp <20	1/2 Y% per day
20 ≤ Temp <30	Y% per day
30 ≤ Temp <40	2Y% per day
40 ≤ Temp <50	4Y% per day
50 ≤ Temp <60	8Y% per day
60 ≤ Temp <70	16Y% per day
70 ≤ Temp	32Y% per day

The nominal self-discharge rate, %PERDAY (% per day), is programmed in an 8-bit value *Self-Discharge Rate* DF 0x2d by the following relation:

$$\text{Self-Discharge Rate} = \%PERDAY / 0.01$$

Battery Electronic Load Compensation

The bq2084-V123 can be configured to compensate for a constant load (as from battery electronics) present in the battery pack at all times. The bq2084-V123 applies the compensation continuously when the charge or discharge is below the digital filter. The bq2084-V123 applies the compensation (BEL) in addition to self-discharge. The compensation occurs at a rate determined by the value stored in *Electronics Load* DF 0x2e. The compensation range is 0 μA–765 μA in steps of approximately 3 μA. The data is stored as follows:

$$\text{Electronics Load} = BEL / 3$$

Midrange Capacity Corrections

The bq2084-V123 applies midrange capacity corrections when the VCOR bit is set in *Gauge Configuration* DF 0x29. The bq2084-V123 adjusts RM to the associated percentage at three different voltage levels: VOC25, VOC50, and VOC75. The VOC values represent the open circuit battery voltage at which RM corresponds to the associated percentage for each threshold.

For the midrange corrections to occur, the temperature must be in the range of 19°C to 31°C inclusive and Current() and AverageCurrent() must both report between –64 mA and 0. The bq2084-V123 makes midrange corrections as shown in the table below. For a correction to occur, the bq2084-V123 must detect the need for correction twice during subsequent 20-s intervals. With the VCOR bit set, the bq2084-V123 makes midrange corrections whenever conditions permit.

If the OTVC bit in *Gauge Configuration* DF 0x29 is set and VCOR = 0, the bq2084-V123 makes two Voltage() measurements, determines the average of the two readings and sets the appropriate RM level. No further RSOC% vs Voltage() validation is performed until after the next device reset.

Table 5. Midrange Corrections

	CONDITION	RESULT
Voltage()	$\geq \text{VOC75}$ and $\text{RelativeStateOfCharge}() \leq 63\%$	$\text{RelativeStateOfCharge}() \rightarrow 75\%$
	$< \text{VOC75}$ and $\text{RelativeStateOfCharge}() \geq 87\%$	$\text{RelativeStateOfCharge}() \rightarrow 75\%$
	$\geq \text{VOC50}$ and $\text{RelativeStateOfCharge}() \leq 38\%$	$\text{RelativeStateOfCharge}() \rightarrow 50\%$
	$< \text{VOC50}$ and $\text{RelativeStateOfCharge}() \geq 62\%$	$\text{RelativeStateOfCharge}() \rightarrow 50\%$
	$\geq \text{VOC25}$ and $\text{RelativeStateOfCharge}() \leq 13\%$	$\text{RelativeStateOfCharge}() \rightarrow 25\%$
	$< \text{VOC25}$ and $\text{RelativeStateOfCharge}() \geq 37\%$	$\text{RelativeStateOfCharge}() \rightarrow 25\%$

Three voltage-based thresholds, *VOC25* DF 0x88–0x89, *VOC50* DF 0x83–0x84, and *VOC75* DF 0x7e–0x7f, are stored in the data flash in mV.

Charge Control

The bq2084-V123 internal charge control is compatible with the constant current/constant voltage profile for Li-Ion. The bq2084-V123 detects primary charge termination on the basis of the tapering charge current during the constant-voltage phase.

Charging Voltage Broadcasts

The bq2084-V123 supports SBS charge control by broadcasting the *ChargingCurrent()* and *ChargingVoltage()* to the Smart Charger address. The bq2084-V123 broadcasts the requests every 10 seconds. The bq2084-V123 updates the values used in the charging current and voltage broadcasts based on the battery's state of charge, voltage, and temperature.

The 16-bit value (mV) for charging voltage is programmed in *Charging Voltage* DF 0x03a–0x3b although it can be set to 0 in different operating conditions. It also sets the base value for determining overvoltage conditions during charging and voltage compliance during a constant-voltage charging methodology.

The 16-bit value, *Over Voltage Margin* DF 0x5d–0x5e, sets the limit over *ChargingVoltage()* in mV that is to be considered as an overvoltage charge-suspension condition.

Charging Current Broadcasts

ChargingCurrent() values are either broadcast to a Level 2 smart battery charger or read from the bq2084-V123 by a Level 3 smart battery charger. The *ChargingCurrent()* may take any of four different values: *Fast-Charging Current* DF (0x3e–0x3f), *Maintenance Charging Current* (DF 0x40–0x41), *Precharge Current* (0x42–0x43) or 0 depending on charge state and operating conditions.

When fast charge is allowed, the bq2084-V123 sets *ChargingCurrent()* to the rate programmed in *Fast-Charging Current* DF 0x3e–0x3f. *Fast-Charging Current* is stored in mA.

When fast charge terminates, the bq2084-V123 sets *ChargingCurrent()* to zero and then to the *Maintenance Charging Current* DF 40 0x41 when the termination condition ceases. The desired maintenance current is stored in mA.

When *Voltage()* is less than EDV0, the bq2084-V123 sets *ChargingCurrent()* to *Precharge Current* DF 0x42, 0x43. Typically this rate is larger than the maintenance rate to charge a deeply depleted pack up to the point where it may be fast charged. The desired precharge rate is stored in mA.

If temperature is between the *Charge Inhibit Temp Low* (DF0x46) and the precharge threshold PC (°C), the bq2084-V123 sets *ChargingCurrent()* to *PreCharge Current*. The threshold is programmed in the *Precharge Temp* DF 0x44. The maximal value of precharge temperature threshold setting is 12.7°C.

$$\text{Precharge Temp} = \text{PC} (\text{°C}) / 0.1$$

The bq2084-V123 also sets *ChargingCurrent()* to the precharge rate if *Voltage()* is less than the value programmed in *Precharge Voltage* DF 0x3c–0x3d. *Precharge Voltage* is programmed in mV.

Alarm Broadcasts to Smart Charger and Host

If any of the bits 8–15 in *BatteryStatus()* are set, the bq2084-V123 broadcasts an *AlarmWarning()* message to the Host address. If any of the bits 12–15 in *BatteryStatus()* are set, the bq2084-V123 also sends an *AlarmWarning()* message to the Smart Charger address. The bq2084-V123 repeats the *AlarmWarning()* messages every 10 seconds until the alarm bits are cleared. All broadcasts can be disabled by setting SM (bit 2) in *Pack Configuration* (DF 0x28).

Precharge Qualification

The bq2084-V123 sets ChargingCurrent() to the precharge rate as programmed in *Precharge Current* DF 0x42-0x43 under the following conditions:

- **Voltage:** The bq2084-V123 requests the precharge charge rate when any cell voltage drops below the precharge threshold or when the EDV0 threshold is detected. Once requested, a precharge rate remains until all cell voltages increase above the precharge threshold and the EDV0 condition does not exist. The precharge threshold is programmed in *Precharge Voltage* DF 0x3c-0x3d.
- **Temperature:** The bq2084-V123 requests the precharge rate when Temperature() is between *Charge Inhibit Temp Low* (DF0x46) and the precharge threshold programmed in *Precharge Temp* 0x44. Temperature() must be equal to or greater than the precharge threshold + 3°C to allow the fast-charge rate.

Charge Suspension

The bq2084-V123 may temporarily suspend charge if it detects a charging fault. A charging fault includes the following conditions.

- **Overcurrent:** An overcurrent condition exists when the bq2084-V123 measures the charge current to be greater than *Charge OC Threshold* (DF 0x12a-0x12b) for a time greater than *Charge OC Time* (DF 0x12c). On detecting an overcurrent condition, the bq2084-V123 turns off the Charge FET. If the Nonremovable Battery bit is not set in *Misc Configuration* DF 0x2a, then the Discharge FET is turned off also. This condition is cleared when the pack is removed or if the Nonremovable Battery bit is set in *Misc Configuration* DF 0x2a and when a discharge current is detected or when SBS AverageCurrent() is less than the *ClearFailCurrent* DF 0x61-0x62 for *FaultResetTime* DF 0x130.
- **Overtemperature:** During charging, an overtemperature condition exists when Temperature() is greater than the *Charge Suspend Temp High* value programmed in DF 0x6d, 0x6e. On detecting an overtemperature condition, if enabled by the OT bit in *Misc Configuration* DF 0x2a the bq2084-V123 turns off the Charge and Discharge FET. The overtemperature condition is cleared when Temperature() is equal to or below *Charge Suspend Temp High Reset* (DF 0x6f -0x70). The condition is also cleared if the pack is removed.
- **Undertemperature:** During charging, an undertemperature condition exists when Temperature() is less than the *Charge Suspend Temp Low* in DF 0x79 or *Charge Inhibit Temp Low* in DF 0x46. On detecting an undertemperature condition the bq2084-V123 turns off the Charge FET. The undertemperature condition is cleared when Temperature() is greater than *Charge Suspend Temp Low* DF 0x79. The condition is also cleared if the pack is removed. The maximal value of *Charge Suspend Temp Low* setting is 12.7°C.
- **Charging exceeds Maximum Charging Time** in DF 0x10f-0x110. If charging time reaches Maximum Charge Time, the Charge FET is turned off. This condition is cleared when the pack detects discharge current or is removed.
- **Cell or Pack Overvoltage:** An overvoltage condition exist when any cell is greater than *Cell Over Voltage Limit* in DF 0x63-0x64 or if Voltage() is greater than *Charging Voltage* in 0x3a-0x3b plus *OvervoltageMargin* in 0x5d-05e. This condition is cleared when the pack is removed or if the Nonremovable Battery bit is set in *Misc Configuration* DF 0x2a and when a discharge current is detected or when SBS AverageCurrent() is less than the *ClearFailCurrent* DF 0x61-0x62 for *FaultResetTime* DF 0x130. Also, the overvoltage conditon must be cleared by Voltage() less than *Charging Voltage* in 0x3a-0x3b plus *OvervoltageMargin* in 0x5d-05e and all cell voltages less than *Cell Over Voltage Reset* in DF 0xe0-0xe1.
- Charging is also temporarily suspended during pulse-charging, but this is not considered a fault condition.

Pulse Charge

The bq2084-V123 is capable of charge control using a pulse-charging algorithm, which allows for charge control in systems where the charger does not control current.

The pulse-charging algorithm uses voltage thresholds and associated time limits for control. These are stored as constants in data flash. The cell voltages are read by the a/d converter every 125 ms during charging. The voltage used for comparison to the thresholds is the highest cell voltage. These thesholds are set by three data

flash constants: Von Charge Voltage, Voff Charge Voltage, and Vmax Charge Voltage. Von is the lowest of these, and is the threshold below which the charge FET is turned on, provided the minimum off time (Pulse Minimum Off Time) has been met. When the voltage crosses the Voff threshold, the maximum on time (Pulse Maximum On Time) begins to count down. When this time has expired, the charge FET is turned off. Any time Vmax is exceeded, the charge FET is turned off immediately.

The rules are:

1. If charge FET is on:
 - a. If voltage above Vmax, turn off.
 - b. Else if voltage above Voff and max on time expired, turn off.
 - c. Else count down max on time time.
2. If charge FET is off:
 - a. If voltage below Von and minimum off time, turn on.
 - b. Else increment off time.

Voltage is sampled every 125 ms; therefore, the minimum off time and maximum on time are in units of 125 ms, and pulse on and off times are integral multiples of 125 ms.

The voltage thresholds can be chosen in such a way that they alter the charge mechanism. If Voff is set equal to Vmax, then every time this threshold is crossed, the charge FET turns off immediately. This effectively disables the maximum charge time, so that the Voff threshold has no effect. In this case, the algorithm can be described as having two voltage thresholds, rather than three. The charge FET simply turns on and off as it crosses the two thresholds.

The minimum off time can be similarly disabled by setting it to zero or one. Due to the sample interval, the charge FET always is off for at least one 125-ms cycle.

Thresholds must be chosen carefully to get the desired charging behavior. For example, if Von is set below charge voltage minus taper voltage, the pack can never detect full charge. During pulse charging, the charge FET remains off until the cells relax to below the Von voltage, which is below the qualification voltage for full charge detection.

During cycle phase of pulse charging (charge FET ON), the voltage can exceed Voff value for a period of 125 ms until next sample is taken and FET is switched OFF. To prevent cell overvoltage termination, or pack overvoltage termination during this period, values for cell OV should be set larger than voltage reached during this period. Reasonable value of cell OV for given charger current I can be calculated, assuming cell impedance of 0.08 Ω /cell, as $V_{(cell)OV} > V_{on} + 0.08 * I$.

Correspondingly, the pack overvoltage margin should be set as $V_{(margin)} > V_{(cell)OV} * n - V_{(charge)}$

where: n = number of series cells.

When charging begins on a depleted battery pack, the voltage is below Voff, and may even stay below Von for some time. This means the pack is under constant charge, with no pulsing, for some part of the charge cycle. As the voltage on the cells rises, it crosses the Voff threshold (or the Vmax threshold if Voff is disabled), and the charge FET turns off. Initially, the off time is short, since the cells are only barely over the threshold and is quickly relaxed to below Von. As the cell voltages rises, the off times become longer and the on times shorter. This effect, in combination with the reduced current drawn by the cells, results in a gradually declining charge current. Eventually, this current falls below the taper current, and the pack detects the full charge condition and stops charging.

The pulse-charging control operates during normal charging conditions and are overridden in case of a fault condition. Charging is stopped for any fault conditions which may occur, such as overtemperature or overcurrent, without regard to the voltage thresholds or time limits.

Primary Charge Termination

The bq2084-V123 terminates charge if it detects a charge-termination condition based on current taper. A charge-termination condition includes the following:

The bq2084-V123 detects a current taper termination when the pack voltage is greater than Charging Voltage (DF 0x3a-0x3b) minus *Current Taper Qualification Voltage* (DF 0x4d-0x4e) and the AverageCurrent() is below the *Current Taper Threshold* (DF 0x4b-0x4c), but greater than the *Charge Detection Current* in DF 0x113-0x114, for a period of *Current Taper Window* (DF 0x4f).

Once the bq2084-V123 detects a Primary Charge Termination, the bq2084-V123 sets the TERMINATE_CHARGE_ALARM and FULLY_CHARGED bits in BatteryStatus(), and turns off the charge FET via the bq29312. The charge FET is turned on when discharge current is detected and is greater than Discharge Detection Current (DF 0x115-0x116), to minimize IR losses. The TERMINATE_CHARGE_ALARM charge current is no longer detected or the pack is removed, but returns if charging is attempted while the FULLY_CHARGED bit is set.

The bq2084-V123 clears the FULLY_CHARGED and TERMINATE_CHARGE_ALARM bit when RelativeStateOfCharge() is less than the programmed *Fully Charged Clear %*. See Table 13 for a summary of BatteryStatus() alarm and status bit operation.

Cell Balancing

The bq2084-V123 balances the cells during charge by discharging those cells above the threshold set in *Cell Balance Threshold* DF 0xe8-0xe9, if the maximum difference in cell voltages exceeds the value programmed in *Cell Balance Min* DF 0xec. For cell balancing, the bq2084-V123 measures the cell voltages at an interval set in *Cell Balance Interval* DF 0xed. On the basis of the cell voltages, the bq2084-V123 either selects the appropriate cell to discharge or adjusts the cell balance threshold up by the value programmed in *Cell Balance Window* 0xea-0xeb when all cells exceed the cell balance threshold or the highest cell exceeds the cell balance threshold by the cell balance window.

Cell balancing only occurs when charging current is detected and the cell balance threshold is reset to the value in *Cell Balance Threshold* at the start of every charge cycle. The threshold is only adjusted once during any balance interval.

If the cells are severely imbalanced during charging, where $V_{CELL(MAX)} - V_{CELL(MIN)} > \text{Cell Imbalance Threshold AND SBS. Current()} > \text{Balance IMAX}$ for a period of *Cell Imbalance time* then the CIM bit in *PF Status* is set.

Table 6. Cell Balancing and Cell Imbalance Programming

NAME	DF ADDRESS	DESCRIPTION
Cell Balance Threshold	0xe8-0xe9	Sets the maximum voltage in mV that each cell must achieve to initiate cell balancing. Programming <i>Cell Balance Threshold</i> to 65,535 disables cell balancing.
Cell Balance Min	0xec	Sets in mV the cell differential that must exist to initiate cell balancing
Cell Balance Window	0xea-0xeb	Sets in mV the amount that the cell balance threshold increases during cell balancing
Cell Balance Interval	0xed	Sets the cell balancing time interval in seconds.
Cell Imbalance Threshold	0xee-0xef	Sets the severe imbalance fault limit for cell imbalance detection
Balance IMAX	0xf2-0xf3	Sets the charge current required to allow a cell imbalance to be detected
Cell Imbalance Time	0x134	Sets the time period during which a cell imbalance must be selected for the bq2084 to enter PF mode.

Display Port

General

The display port drives a 3-, 4-, or 5-LED bar-graph display. The display is activated by a logic signal on the DISP input. The bq2084-V123 can display RM in either a relative or absolute mode with each LED representing a percentage of the full-battery reference. In relative mode, the bq2084-V123 uses FCC as the full-battery reference; in absolute mode, it uses Design Capacity (DC). The DMODE bit in *Pack Configuration* DF 0x28 programs the bq2084-V123 for the absolute or relative display mode. The LED bits program the 3-, 4-, or 5-LED option.

Activation

The display may be activated at any time by a high-to-low transition on the DISP input. This is usually accomplished with a pullup resistor and a pushbutton switch. Detection of the transition activates the display and starts a 4-s display timer. Reactivation of the display requires that the DISP input return to a logic-high state

and then transition low again. The second high-to-low transition can be detected only after the display timer expires. If unused, the DISP input must be pulled up to VCC. If the EDV0 bit is set, the bq2084-V123 disables the LED display.

Display Modes

In relative mode, each LED output represents 20%, 25%, or 33% of the RelativeStateOfCharge() value. In absolute mode, each LED output represents 20%, 25% or 33% of the AbsoluteStateOfCharge() value. Table 7 shows the display options for 5 LEDs for 4 LEDs, Table 8 and Table 9 for 3 LEDs. In either mode, the bq2084-V123 blinks the LED display if RemainingCapacity() is less than RemainingCapacityAlarm(). The display is disabled if EDV0 = 1.

Table 7. Display Mode for Five LEDs

CONDITION RELATIVE OR ABSOLUTE	FIVE-LED DISPLAY OPTION				
STATEOFCHARGE()	LED1	LED2	LED3	LED4	LED5
EDV0 = 1	OFF	OFF	OFF	OFF	OFF
<20%	ON	OFF	OFF	OFF	OFF
≥20%, < 40%	ON	ON	OFF	OFF	OFF
≥40%, < 60%	ON	ON	ON	OFF	OFF
≥60%, < 80%	ON	ON	ON	ON	OFF
≥80%	ON	ON	ON	ON	ON

Table 8. Display Mode for Four LEDs

CONDITION RELATIVE OR ABSOLUTE	FOUR-LED DISPLAY OPTION			
STATEOFCHARGE()	LED1	LED2	LED3	LED4
EDV0 = 1	OFF	OFF	OFF	OFF
<25%	ON	OFF	OFF	OFF
≥25%, < 50%	ON	ON	OFF	OFF
≥50%, < 75%	ON	ON	ON	OFF
≥75%	ON	ON	ON	ON

Table 9. Display Mode for Three LEDs

CONDITION RELATIVE OR ABSOLUTE	THREE-LED DISPLAY OPTION		
STATEOFCHARGE()	LED1	LED2	LED3
EDV0 = 1	OFF	OFF	OFF
<34%	ON	OFF	OFF
≥34%, < 67%	ON	ON	OFF
≥67%	ON	ON	ON

Li-Ion Protection

The bq2084-V123 in conjunction with the bq29312 provides protection for Li-Ion batteries, as shown in Table 10. The bq2084-V123 measures temperature and current and uses the bq29312 to measure individual cell voltage. The bq2084-V123 uses this information to determine protection requirements, control the safety FETs or SAFE output as necessary. It is recommended that the bq2084-V123 protection control be validated by two successive measurements by setting VOD=1 in *Misc Configuration*.

The bq29312 can independently detect and protect the load from an overload (OL) or short circuit in charge (SCC) or discharge (SCD). The bq29312 sets the appropriate FET state and then alerts the bq2084-V123 with the XALERT output when ever a protection threshold is breached and its associated delay time has expired. The bq2084-V123 then determines if and when the FETs should be turned back on.

Table 10. CVOV and CVUV Flags in PackStatus()

FLAG	SET CONDITION	DSG FET	CHG FET	CLEAR CONDITION (see Note 1)
CVOV	Voltage() = ChargingVoltage() + Over Voltage Margin	ON	OFF (see Note 2)	Voltage() < ChargingVoltage()
	VCELL(ANY) = Cell Over Voltage	ON	OFF (see Note 2)	VCELL(ALL) < Cell Over Voltage Reset
CVUV	VCELL(ANY) = Cell Under Voltage	OFF (see Note 3)	ON	VCELL(ALL) > Cell Under Voltage Reset
	AverageCurrent() < – Over Load Current	OFF (see Note 3)	ON	AverageCurrent() < – Current Fault Clear Threshold

(1) Clear is detected and controlled by the bq2084-V123.

(2) On if there is a discharge current ≥ 150 mA

(3) On if there is a charge current ≥ 50 mA

Protection Configuration

1st Level Cell Voltage Thresholds

The cell undervoltage (VUV) and overvoltage (VOV) limits are programmed in *Cell Under Voltage* and *Cell Over Voltage* DF 0x65–0x66, DF 0x63–0x64, respectively. Both values are stored in mV. *Cell Over Voltage Reset* DF 0xe0–0xe1 and *Cell Under Voltage Reset* 0xe2–0xe3 set the reset points in mV for these safety parameters.

Safety Overvoltage Threshold

The safety voltage threshold is programmed in *Safety Over Voltage* DF 0x6b–0x6c. It is stored in mV. Exceeding the Safety Voltage for a period determined by the MISC Config VOD bit causes permanent failure if enabled by PFConfig.

Overcurrent Thresholds

Discharge current threshold is programmed in *Discharge OC Threshold* DF 0x12d–0x12e. The discharge overcurrent must exist for time programmed in *Discharge OC Time* DF 0x12f. When an discharge overcurrent condition is detected the discharge FET is turned off. Similarly, a charge overcurrent is programmed in *Charge OC Threshold* DF 0x12a–0x12b. The charge overcurrent must exist for the time programmed in *Charge OC Time* DF 0x12c or *Charge OC Time* DF 0x12c. When a charge overcurrent condition is detected the charge FET is turned off.

Temperature Thresholds

The Safety Over Temperature in Charge (SOTC) threshold is programmed in *Safety Over Temperature in Charge* DF 0x75–0x76 and Safety Over Temperature in Discharge (SOTD) threshold is programmed in *Safety Over Temperature in Discharge* DF 0x77–0x78.

SOTC is stored as *Safety Over Temperature in Charge* = SOTC/0.1 (°C) as an unsigned integer

SOTD is stored as *Safety Over Temperature in Discharge* = SOTD/0.1 (°C) as an unsigned integer. Exceeding the Safety Temperatures causes permanent failure if enabled by PFConfig.

There are also temperature thresholds to disable both charge and discharge FETs and to set the SBS Battery Status Overtemperature bit. The thresholds are set according to whether discharge or charging is detected. The *Charge Suspend Temp High* threshold is stored in DF 0x6d–0x6e with the reset threshold stored in DF 0x6f–0x70. Likewise the *Over Temperature Discharge* threshold is stored in DF 0x71–0x72 with the reset threshold stored in DF 0x73–0x74.

The *Charge Suspend Temp Low* threshold (CSTL) is stored in *Charge Suspend Temp Low* DF 0x79–0x7a and is stored as *Charge Suspend Temp Low* = CSTL/0.1 (°C) as a signed integer. A *Charge Suspend Temp Low* turns off the charge FET. The maximal value of *Charge Suspend Temp Low* setting is 12.7 °C.

bq2084-V123

SLUS619A – AUGUST 2004 – REVISED JANUARY 2005

AFE Configuration

The AFE protection limits are programmed as specified in the bq29312 data sheet.

AFE Over Load DF 0xc5 sets the AFE overload protection threshold.

AFE Over Load Delay DF 0xc6 sets the delay timing for overload protection.

AFE Short Circuit in Charge DF 0xc7 sets the AFE short circuit in charge protection threshold and delay time.

AFE Short Circuit in Discharge DF 0xc8 sets the AFE short circuit in discharge protection threshold and delay time.

SMBus command 0x46 can be used to string read the AFE RAM with the AFE address 0x00 first, if the bq2084-V123 is not sealed as indicated by bit 5 of PackStatus.

Table 11. Overcurrent Protection

FAILURE	FET STATUS	CLEAR CONDITIONS
NR=1		
AFE OLV	CHG on, ZVCHG off, DSG off	Same AFE SCD
AFE SCC	CHG off, ZVCHG off, DSG on	Average Current (<) < Clear Fail Current (DF 0x61/2) for Fault Reset Time (DF 0x130), or discharge current > discharge detection current (DF 0x115/6)
AFE SCD	CHG on, ZVCHG off, DSG off	Average Current (>=) ≥ –Clear Fail Current (DF 0x61/2) for Fault Reset Time (DF 0x130), or charge current > charge detection current (DF 0x113/4)
GG Charge OC (set by DF 0x12a to 0x12c)	CHG off, ZVCHG off, DSG on	Same AFE SCC
GG Discharge OC (set by DF 0x12d to 0x12f)	CHG on, ZVCHG off, DSG off	Same AFE SCD
NR=0		
FAILURE	FET STATUS	EXIT CONDITIONS
AFE OLV	All FETs off	RRES=high
AFE SCC	All FETs off	PRES=high
AFE SCD	All FETs off	PRES=high
GG Charge OC (set by DF 0x12a to 0x12c)	All FETs off	PRES=high
GG Discharge OC (set by DF 0x12d to 0x12f)	All FETs off	PRES=high

AFE Integrity Check

The bq2084-V123 checks the programming of the AFE registers at a period determined by *AFE Check Time* DF 0xfb. The units of the check period are seconds unless the bq2084-V123 is in sleep mode, in which case the period is *AFE Check Time x Sleep Current Multiplier* (DF 0xfd). If the data is not correct, the bq2084-V123 increments an internal counter until it reaches the *AFE Fail Limit* (DF 0xe4). Setting *AFE Check Time* to 0 disables this function.

When the internal AFE Fail counter reaches *AFE Fail Limit*, then the AFE bit in PF Status is set.

AFE Watchdog Fault and Clear

The bq29312 has a feature where the 32 kHz output (CLKOUT, pin 35) of the bq2084-V123 is used to drive its internal clock. If this clock fails, a fault is declared in the AFE. See the bq29312 data sheet for further details.

The fault is cleared automatically on return of the 32-kHz input via the bq2084-V123 CLKOUT pin.

Permanent Failure Mode ($\overline{\text{SAFE}}$ Output)

The $\overline{\text{SAFE}}$ output of the bq2084-V123 provides an additional level of safety control. The active low safety output can blow a fuse or control another switch on the basis of temperature, pack-voltage cell-voltage, CHG FET Failure, severe cell imbalance or an integrity check of the AFE and Data Flash configuration registers.

The bq2084-V123 can also activate the $\overline{\text{SAFE}}$ output and set the PF Flag based on the $\overline{\text{PFIN}}$ input. If this pin is low for *PFIN Time* seconds ± 1 s then the $\overline{\text{PFIN}}$ bit in PF Status is set.

The $\overline{\text{SAFE}}$ output can be driven low in any of the following conditions and the bq2084-V123 sets the *PF Flag* register (DF 0x11e) to 0x66 (011001100). The activation of the $\overline{\text{SAFE}}$ output and the setting of the *PF Flag* can be enabled or disabled for different safety option per the *PF Config* (DF 0x11f) register settings.

The $\overline{\text{SAFE}}$ output and PF Flag register can only be cleared using a series of ManufacturerAccess() commands.

Table 12. $\overline{\text{SAFE}}$ Activation Conditions

CONDITION	ACTIONS
Voltage() > <i>Safety Over Voltage</i> (DF 0x6b and 0x6c),	SOV and PF set
Temperature() > <i>Safety Over Temperature in Charge</i> (DF 0x75 and 0x76)	SOTC and PF set
Temperature() > <i>Safety Over Temperature in Discharge</i> (DF 0x77 and 0x78)	SOTD and PF set
When Miscellaneous Configuration (0x2a) bit 13 AC is set, and the number of AFE failures has reached the <i>AFE Fail Limit</i> (DF 0xe4)	AFE and PF set
When $V_{\text{CELL}(\text{MAX})} - V_{\text{CELL}(\text{MIN})} > \text{Cell Imbalance Threshold}$ (DF 0xee, 0xef) during charging	CIM and PF set
If charge FET is off, and charge current greater than FET Fail charge current stored in DF 0x125–0x126 for the time determined by FET Fail time in DF 0x129, or if discharge FET is off and discharge current greater than FET Fail discharge current stored in DF 0x127–0x128 for the time determined by FET Fail time in DF 0x129.	FETF and PF set
The $\overline{\text{PFIN}}$ input has detected a low state for <i>PFIN Time</i> in consecutive seconds, as determined by DF 0x120	$\overline{\text{PFIN}}$, PF set

NOTE: $\overline{\text{SAFE}}$ output activated and *PF Flag* set only if enabled by *PF Config* (DF 0x0x11f)

Permanent Failure Status (PF Status)

PF Status DF 0x11d contains the flags for the cause of the permanent failure mode.

b7	b6	b5	b4	b3	b2	b1	b0
PFF	PFIN	FETF	CIM	AFE	SOTD	SOTC	SOV

SOV

The SOV bit indicates a safety overvoltage occurred which if enabled by PF Config would cause the $\overline{\text{SAFE}}$ output to activate.

- 0 SOV fault not detected (default)
- 1 SOV fault detected

SOTC

The SOTC bit indicates a safety overtemperature in charge occurred which if enabled by PF Config would cause the $\overline{\text{SAFE}}$ output to activate.

- 0 SOTC fault not detected (default)
- 1 SOTC fault detected

SOTD

The SOTD bit indicates a safety overtemperature in discharge occurred which if enabled by PF Config would cause the $\overline{\text{SAFE}}$ output to activate.

- 0 SOTD fault not detected (default)
- 1 SOTD fault detected

AFE

The AFE bit indicates an AFE integrity fault state occurred which if enabled by PF Config would cause the $\overline{\text{SAFE}}$ output to activate.

- 0 AFE is operating correctly (default)
- 1 AFE Integrity check fail limit reached

CIM

The CIM bit indicates that a severe cell imbalance occurred during charging, which if enabled by PF Config, would cause the $\overline{\text{SAFE}}$ output to activate.

- 0 All cells are within the *Cell Imbalance Threshold* (default)
- 1 There is a severe cell imbalance

FETF

The FETF bit indicates a FET or FET driver failure occurred, which if enabled by PF Config would cause the $\overline{\text{SAFE}}$ output to activate.

- 0 The FETs are operating normally (default)
- 1 The FETs or FET drivers have a fault

PFIN

The PFIN bit is used to indicate that the output of the 2nd level protector has activated.

- 0 The PFIN input is high (default)
- 1 The PFIN input drive and held low by 2nd level protector output

PFF

The PFF bit is used to indicate that current has been detected when the fuse has been set to be blown.

- 0 Current not detected with fuse blown
- 1 Current detected with fuse blown

Permanent Failure Configuration (PF Config)

PF Config DF 0x11f contains the enable/disable configuration that determines if the $\overline{\text{SAFE}}$ output is activated and the PF Flag set for each possible failure mode.

b7	b6	b5	b4	b3	b2	b1	b0
-	XPFIN	XFETF	XCIM	XAFE	XSOTD	XSOTC	XSOV

XSOV

The XSOV bit enables or disables the activation of $\overline{\text{SAFE}}$ and the setting of the PF Flag when *PF Status* SOV is set.

- 0 Activation disabled (default)
- 1 Activation enabled

XSOTC

The XSOTC bit enables or disables the activation of $\overline{\text{SAFE}}$ and the setting of the PF Flag when *PF Status* SOTC is set.

- 0 Activation disabled (default)
- 1 Activation enabled

XSOTD

The XSOTD bit enables or disables the activation of $\overline{\text{SAFE}}$ and the setting of the PF Flag when *PF Status* SOTD is set.

- 0 Activation disabled (default)
- 1 Activation enabled

XAFE

The XAFE bit enables or disables the activation of $\overline{\text{SAFE}}$ and the setting of the PF Flag when *PF Status* AFE is set. Bit 13 of *Miscellaneous Config* DF 0x2a also needs to be set for activation.

- 0 Activation disabled (default)
- 1 Activation enabled

XCIM

The XCIM bit enables or disables the activation of $\overline{\text{SAFE}}$ and the setting of the PF Flag when *PF Status* CIM is set.

- 0 Activation disabled (default)
- 1 Activation enabled

XFETF

The XFETF bit enables or disables the activation of $\overline{\text{SAFE}}$ and the setting of the PF Flag when *PF Status* FETF is set.

- 0 Activation disabled (default)
- 1 Activation enabled

XPFIN

The XPFIN bit enables or disables the activation of $\overline{\text{SAFE}}$ and the setting of the PF Flag when *PF Status* PFIN is set.

- 0 Activation disabled (default)
- 1 Activation enabled

Permanent Failure Flag (PF Flag)

PF Flag DF 0x11e contains the flag indicating if the $\overline{\text{SAFE}}$ output has been activated.

STATE	b7	b6	b5	b4	b3	b2	b1	b0
Clear	0	0	0	0	0	0	0	0
Set	0	1	1	0	0	1	1	0

PF Flag

The PF Flag indicates that the $\overline{\text{SAFE}}$ output of the bq2084-V123 has been activated.

- 0x00 $\overline{\text{SAFE}}$ output high (default)
- 0x66 $\overline{\text{SAFE}}$ output activated

An example circuit using the $\overline{\text{SAFE}}$ output to blow a fuse is shown in Figure 2.

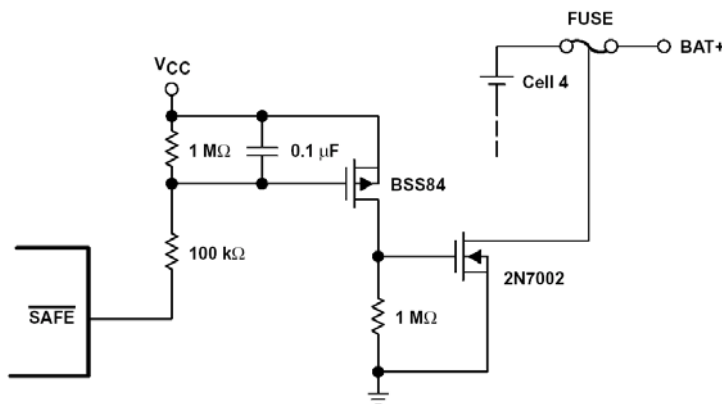

Figure 2. Example $\overline{\text{SAFE}}$ Circuit Implementation

Low-Power Modes

The bq2084-V123 enters sleep mode when the charge and discharge current is less than the threshold programmed in *Sleep Current Threshold* DF 0xfc, the SMBus lines are low for at least 2s, and bit 12 of *Misc. Configuration* DF 0x2a is set to zero. Additionally, PRES must be pulled high if the NR bit in Misc Config is set to 0. The bq2084-V123 wakes up periodically to monitor voltage and temperature and to apply self-discharge adjustment. The sleep period is set in *Sleep Timer* DF 0xfe. The bq2084-V123 wakes up at a period set by *Sleep Current Multiplier* DF 0xfd multiplied by *Sleep Time* to measure current. The bq2084-V123 comes out of sleep when either of the SMBus lines go high or when the current is measured and it is greater than the *Sleep Current Threshold*.

The sleep current threshold, SLP (mA), is stored in *Sleep Current Thresh* DF 0xfc as:

$$\text{Sleep Current Thresh} = \text{SLP(mA)}/0.5$$

bq2084-V123

SLUS619A – AUGUST 2004 – REVISED JANUARY 2005

The wake-up period for current measurement, WAT(s), is set using the following formula:

$$\text{Sleep Current Multiplier} \times \text{Sleep Time} = \text{WAT(s)}$$

During sleep mode both charge and discharge FETs are turned off if the NR bit in Misc Config is cleared. If the bq2084-V123 is in Non-Removable mode where NR=1, then the discharge FET retains its state on entry to sleep.

Shutdown Mode

The bq2084-V123 goes into shutdown, in which all FETs are turned off and the pack electronics are powered down (including the bq2084-V123), when SBS.Voltage() falls below *Shutdown Voltage* DF 0x7c-0x7d and Voltage at the Pack pin is less than VPACK threshold (DF 0x131, 0x132) both for 2 consecutive samples (1 to 2s).

Vpack is programmed in units of 0.935 mV/count, and has tolerance of $\pm 6\%$. For example, to set 12 V as Vpack Threshold, the program value should be $12000/0.935 = 12834$.

When the DSG FET is turned on, the pack voltage is very close to the battery voltage even with no charger attached. Therefore, to enter the shutdown. The Vpack threshold should be set higher than the shutdown threshold plus the tolerance.

The bq2084-V123 can also be instructed to enter Shutdown mode via the *ManufacturerAccess()* command. When the command is sent to the bq2084-V123, the bq29312 is instructed to enter shutdown mode by the bq2084-V123. This forces the chipset into its lowest power mode. The bq2084-V123 does not issue a shutdown command to the AFE unless the pack voltage is less than the Vpack Threshold. Program the Vpack threshold higher than the SBS.Voltage() when ship command is issued. Exit from this mode is only achieved by application of a charger.

After exiting shutdown mode, the bq2084-V123 does not enter the shutdown mode again until the *Shutdown Timer* (DF 0x133, units are seconds) has expired even if the correct conditions are present. After the *Shutdown Timer* has expired, the SMBus command or voltage and current conditions enables the bq2084-V123 to enter shutdown mode.

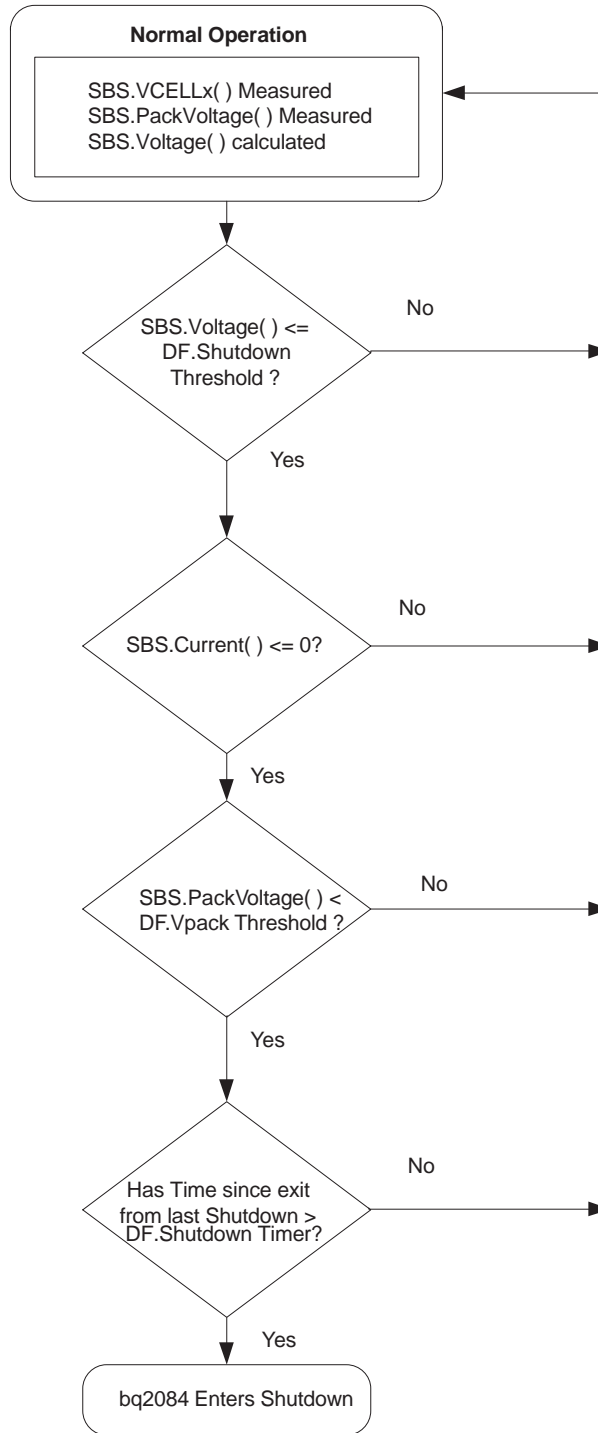

Figure 3. Shutdown Flow Chart in Normal Operation

Defaults

Non-Removable Pack

DF.ShutdownVoltage = 2.8 V x Number of Series cells

DF.ShutdownTimer = 2 s

Note: VpackThreshold must be greater than Shutdown voltage + 6%.

Removable Pack

DF.ShutdownVoltage = 2.8 V x Number of Series cells

DF.ShutdownTimer = 20 s

Note: VpackThreshold must be greater than Shutdown voltage + 6%.

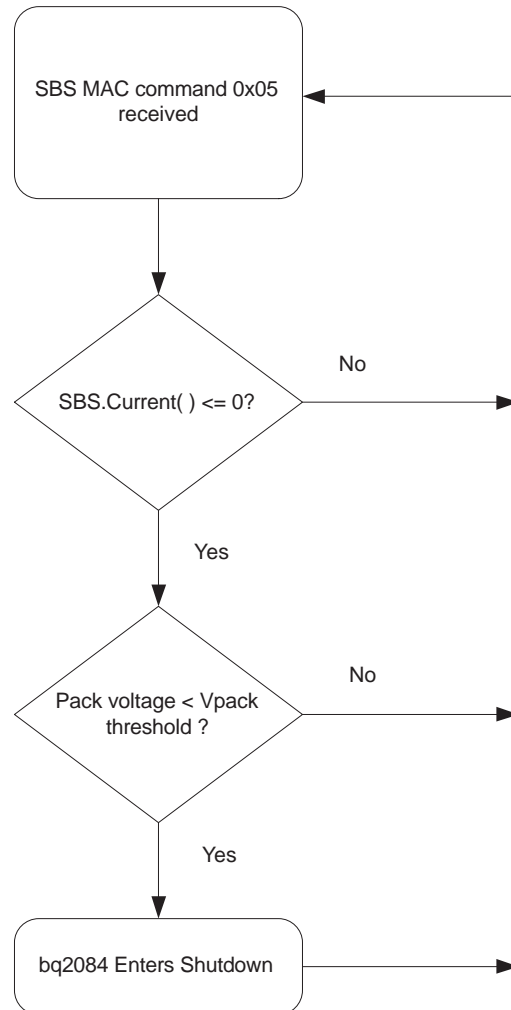
Figure 4. Shutdown Flow Chart in SBS MAC

Reset Conditions

On power up, the entire IC is reset and data is loaded from Data Flash to configure the SBS Data and the battery management solution. On a partial reset (loss of VCC but RBI holds RAM valid), a limited number of locations are taken. These actions are the following:

- The AFE registers are rewritten.
- PackStatus() EDV2 flag is cleared.
- BatteryStatus() DISCHARGING flag is cleared.
- The charger and alarm broadcast period is set to 10 seconds between broadcasts.

Communication

The bq2084-V123 includes an SMBus communication port. The SMBus interface is a 2-wire bidirectional protocol using the SMBC (clock) and SMBD (data) pins. The communication lines are isolated from VCC and may be pulled up higher than VCC. Also, the bq2084-V123 does not pull these lines low if VCC to the part is zero. The communication ports allow a host controller, an SMBus compatible device, or other processor to access the memory registers of the bq2084-V123. In this way a system can efficiently monitor and manage the battery.

SMBus

The SMBus interface is a command-based protocol. A processor acting as the bus master initiates communication to the bq2084-V123 by generating a start condition. A start condition consists of a high-to-low transition of the SMBD line while the SMBC is high. The processor then sends the bq2084-V123 device address of 0001011 (bits 7–1) plus a R/W bit (bit 0) followed by an SMBus command code. The R/W bit (LSB) and the command code instruct the bq2084-V123 to either store the forthcoming data to a register specified by the SMBus command code or output the data from the specified register. The processor completes the access with a stop condition. A stop condition consists of a low-to-high transition of the SMBD line while the SMBC is high. With SMBus, the most-significant bit (MSB) of a data byte is transmitted first. In some instances, the bq2084-V123 acts as the bus master. This occurs when the bq2084-V123 broadcasts charging requirements and alarm conditions to device addresses 0x12 (SBS Smart Charger) and 0x10 (SBS Host Controller.)

SMBus Protocol

The bq2084-V123 supports the following SMBus protocols:

- Read word
- Write word
- Block read

A processor acting as the bus master uses the three protocols to communicate with the bq2084-V123. The bq2084-V123 acting as the bus master uses the write word protocol.

The SMBD and SMBC pins are open drain and require external pullup resistors. A 1-M Ω pulldown resistor in the battery pack on SMBC and SMBD is required to assure the detection of the SMBus off-state, the performance of automatic offset calibration, and the initiation of the low-power sleep mode when the battery pack is removed.

SMBus Packet Error Checking

The bq2084-V123 supports packet error checking as a mechanism to confirm proper communication between it and another SMBus device. Packet error checking requires that both the transmitter and receiver calculate a packet error code (PEC) for each communication message. The device that supplies the last byte in the communication message appends the PEC to the message. The receiver compares the transmitted PEC to its PEC result to determine if there is a communication error.

PEC Protocol

The bq2084-V123 can receive or transmit data with or without PEC. Figure 5 shows the communication protocol for the read word, write word, and read block messages without PEC. Figure 6 includes PEC.

In the read word protocol, the bq2084-V123 receives the PEC after the last byte of data from the host. If the host does not support PEC, the last byte of data is followed by a stop condition. After receipt of the PEC, the bq2084-V123 compares the value to its calculation. If the PEC is correct, the bq2084-V123 responds with an ACKNOWLEDGE (ACK). If it is not correct, the bq2084-V123 responds with a NOT ACKNOWLEDGE (NACK) and sets an error code. In the write word and block read, the host generates an ACK after the last byte of data sent by the bq2084-V123. The bq2084-V123 then sends the PEC and the host acting as a master-receiver generates a NACK and a stop condition.

bq2084-V123

SLUS619A – AUGUST 2004 – REVISED JANUARY 2005

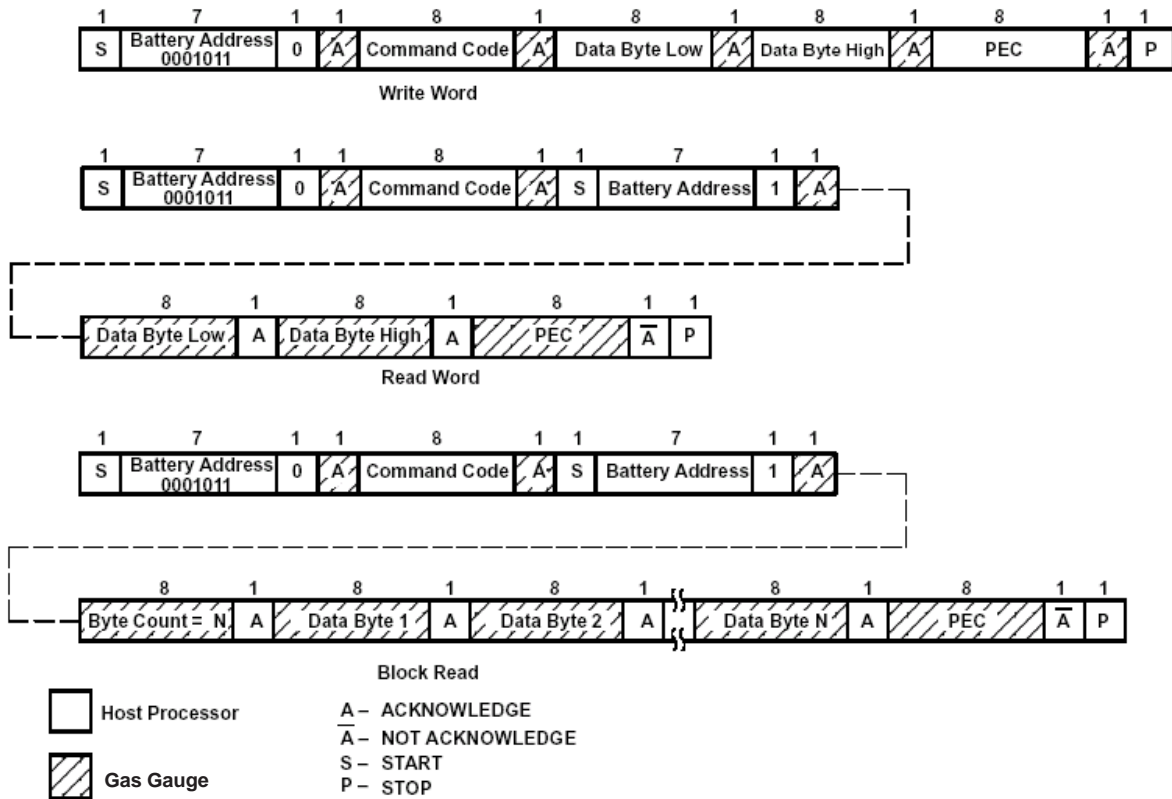

Figure 5. SMBus Communication Protocol Without PEC

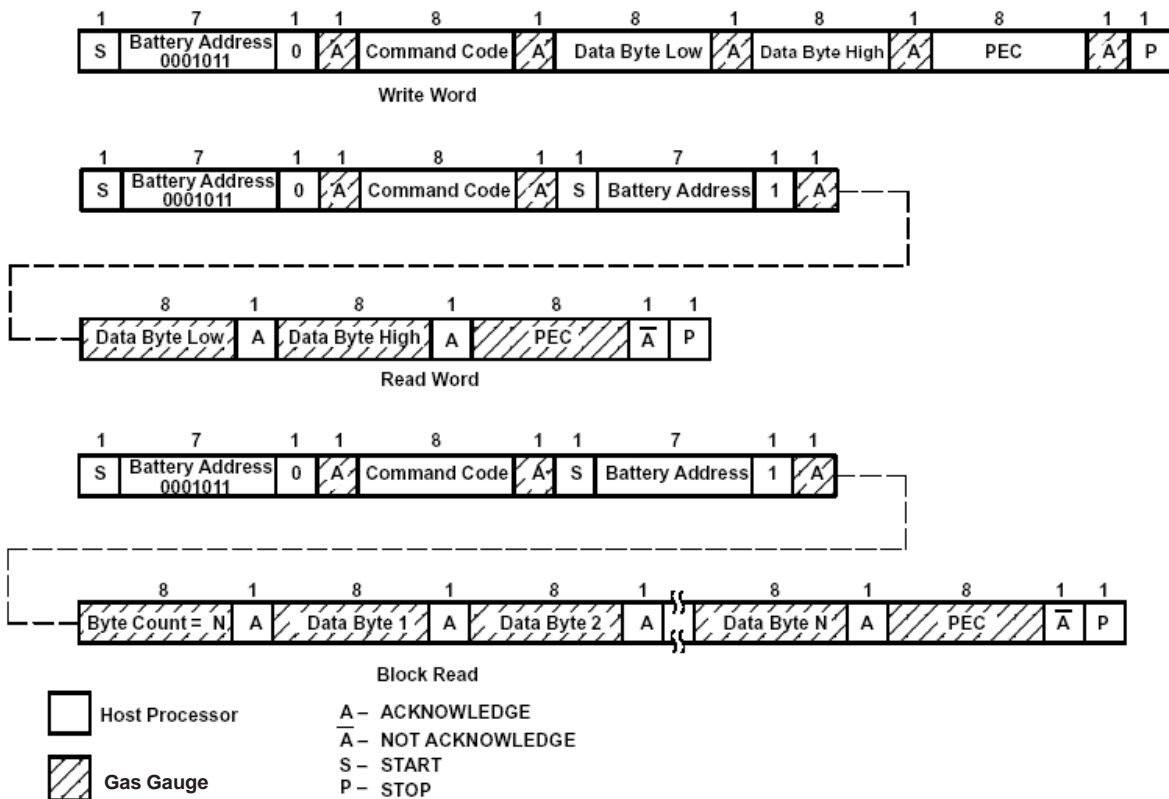

Figure 6. SMBus Communication Protocol With PEC

PEC Calculation

The basis of the PEC calculation is an 8-bit cyclic redundancy check (CRC-8) based on the polynomial $C(X) = X^8 + X^2 + X + 1$. The PEC calculation includes all bytes in the transmission, including address, command, and data. The PEC calculation does not include ACKNOWLEDGE, NOT ACKNOWLEDGE, start, stop, and repeated start bits.

For example, the host requests RemainingCapacity() from the bq2084-V123. This includes the host following the read word protocol. The bq2084-V123 calculates the PEC based on the following 5 bytes of data, assuming the remaining capacity of the battery is 1001 mAh.

- Battery Address with R/W = 0: 0x16
- Command Code for RemainingCapacity(): 0x0f
- Battery Address with R/W = 1: 0x17
- RemainingCapacity(): 0x03e9

For 0x160f17e903, the bq2084-V123 transmits a PEC of 0xe8 to the host.

PEC Enable in Master Mode

The PEC for master mode broadcasts to the charger, host, or both can be enabled/disabled with the combination of the bits HPE and CPE in *Pack Configuration DF* 0x28.

SMBus On- and Off-State

The bq2084-V123 detects whether the SMBus enters the Off State by monitoring the SMBC and SMBD lines. When both signals are continually low for at least 2.0 s, the bq2084-V123 detects the Off State. When the SMBC and SMBD lines go high, the bq2084-V123 detects the On State and can begin communication within 1 ms. One-MΩ pulldown resistors on SMBC and SMBD are recommended for reliable Off State detection.

Command Codes

The SMBus command codes are in (). Temperature(), Voltage(), Current(), and AverageCurrent(), performance specifications are at bq29312 regulated VCC (V(REG)) and a temperature of -20°C to 85°C.

Manufacturer Access() (0x00)

Description: This function provides writable command codes to control the bq2084-V123 during normal operation and pack manufacture. Writing the command code to SMB command 0x00 causes following reads with the SMB command 0x00 to return the word indicated in the table. The following commands are available:

COMMAND CODE	NAME	DESCRIPTION
0x0001	Device Type	Returns IC part number so it can be read, i.e., 2084 (0x0824)
0x0002	Firmware Rev	Returns firmware version so it can be read
0x0003	EDV Level	Returns the pending end-of-discharge voltage level so it can be read
0x0004	Manufacturer Status	Returns the battery system status so it can read
0x0005	SHIP Command	Instructs the bq2084-V123 to instruct the bq29312 to enter ship mode
0x062b	Seal	Instructs the bq2084-V123 to restrict access to those functions listed in Table 3. The bq2084-V123 completes the seal function and clears ManufacturerAccess().

The Manufacture Status word is defined as:

B15	B14	B13	B12	B11	B10	B9	B8
FET1	FET0	PF1	PF0	STATE3	STATE2	STATE1	STATE0
b7	b6	b5	b4	b3	b2	b1	b0
0	0	0	0	1	0	1	0

FET1, FET0

Indicated the state of the charge and discharge FETs

- 0,0 Both charge and discharge FETs are on.
- 0,1 Charge FET is off, discharge FET is on.

bq2084-V123

SLUS619A – AUGUST 2004 – REVISED JANUARY 2005

1,0 Both charge and discharge FETs are off.

1,1 Charge FET is on, discharge FET is off.

PF1, PF0

Indicates permanent failure cause when permanent failure indicated by STATE3–STATE0

0,0 Fuse is blown

0,1 Cell imbalance failure

1,0 Safety voltage failure

1,1 FET failure

STATE3, STATE2, STATE1, STATE0

Indicates battery state as defined in the State and Status bit Summary.

Purpose: The ManufacturerAccess() function provides the system host access to bq2084–V123 functions that are not defined by the SBD.

SMBus protocol: Read or write word

Input/Output: Word

Table 13. State and Status Bit Summary

STATE	MAC MODE (MSB)	CC()	CV()	CHG FET(1)	DSG FET	ZVCHG FET	FUSE	POWER MODE
wakeup	0x00 Wake up	0	0	off(2)	on	on(3)	ok	normal
precharge	0x03 Precharge	PC	CV	off(2)	on	on(4)	ok	normal
chargesusp	0x04 Charge suspension	FC	CV	off	on	off	ok	normal
terminatecharge	0x07 Charge Terminate	MC	CV	off	on	off	ok	normal
normalcharge	0x05 Charge	FC(5)	CV	on	on	off	ok	normal
provisionalcharge	0x01 Normal	0	0	off	on	off	ok	normal
normaldischarge		FC	CV	on	on	off	ok	normal
depleted	0x0e System Present	PC	CV	off	off	off	ok	normal
depleted_ac		PC	CV	off	off	off(4)	ok	normal
overheatdischarge		FC	CV	off	off	off	ok	normal
overheatcharge		FC	CV	off	off	off	ok	normal
battfail_overcharge		0	0	off	on	off	ok	normal
battfail_lowtemp		0	0	off	on	off	ok	normal
battfail_chargeterminate		0x08 Fault Charge Terminate	0	0	off	on	off	ok
battfail_afe_chg	0x0c Battery Failure	0	0	off	off(6)	off	ok	normal
battfail_afe_dsg		FC	CV	off(6)	off	off	ok	normal
battfail_chg	0x0a Over Current	0	0	off	off(6)	off	ok	normal
battfail_dsg		FC	CV	off(6)	off	off	ok	normal
removed	0x0f Battery Out	FC	CV	off	off	off	ok	normal
sleep	0x0d Sleep	0	0	off	off(7)	off	ok	low
permanent_failure	0x09 Permanent Failure	0	0	off	off	off	blow	low

PC—precharge current, FC—fast charge current, CV—charge voltage

(1) CHG FET always on if discharge current greater than Discharge Detection Current (DF 0x115, 0x116)

(2) On if FET Config = 01 (Common precharge, charge FET)

(3) ZVCHG FET on, OD FET off if FET Config = 00 or 02 (ZVCHG FET or precharge FET)

(4) ZVCHG FET on, OD FET off if FET Config = 00 (ZVCHG FET), or ZVCHG FET off, OD FET on if FET Config = 02 (precharge FET)

(5) 0 if CVOV or PC is not CVOV and minimum cell voltage is less than the precharge cell voltage threshold

(6) If MiscConfig.Nonremoveable Battery is set then FET is on.

(7) Discharge FET is on if NR of Misc Config is set to 1.

RemainingCapacityAlarm() (0x01)

Description: Sets or gets the low-capacity threshold value. Whenever the RemainingCapacity() falls below the low-capacity value, the bq2084-V123 sends AlarmWarning() messages to the SMBus host with the REMAINING_CAPACITY_ALARM bit set. A low-capacity value of 0 disables this alarm. The bq2084-V123 initially sets the low-capacity value to *Remaining Capacity Alarm* value programmed in DF 0x02–0x03. The low-capacity value remains unchanged until altered by the RemainingCapacityAlarm() function. The low-capacity value may be expressed in either current (mA) or power (10 mWh) depending on the setting of the BatteryMode() CAPACITY_MODE bit.

Purpose: The RemainingCapacityAlarm() function can be used by systems that know how much power they require to save their operating state. It enables those systems to more finely control the point at which they transition into suspend or hibernate state. The low-capacity value can be read to verify the value in use by the bq2084-V123 low-capacity alarm.

SMBus protocol: Read or write word

Input/Output: Unsigned integer-value below which Low Capacity messages are sent.

bq2084-V123

SLUS619A – AUGUST 2004 – REVISED JANUARY 2005

	BATTERY MODES	
	CAPACITY_MODE BIT = 0	CAPACITY_MODE BIT = 1
Units	mAh at C/5	10 mWh at P/5
Range	0–65,535 mAh	0–65,535 10 mWh
Granularity	Not applicable	
Accuracy	See RemainingCapacity()	

RemainingTimeAlarm() (0x02)

Description: Sets or gets the *Remaining Time Alarm* value. Whenever the *AverageTimeToEmpty()* falls below the remaining time value, the bq2084-V123 sends *AlarmWarning()* messages to the SMBus host with the *REMAINING_TIME_ALARM* bit set. A remaining time value of 0 effectively disables this alarm. The bq2084-V123 initially sets the remaining time value to the *Remaining Time Alarm* value programmed in DF 0x00–0x01. The remaining time value remains unchanged until altered by the *RemainingTimeAlarm()* function.

Purpose: The *RemainingTimeAlarm()* function can be used by systems that want to adjust when the remaining time alarm warning is sent. The remaining time value can be read to verify the value in use by the bq2084-V123 *RemainingTimeAlarm()*.

SMBus protocol: Read or write word

Input/Output: Unsigned integer—the point below which remaining time messages are sent.

Units: Minutes

Range: 0 to 65,535 minutes

Granularity: Not applicable

Accuracy: See *AverageTimeToEmpty()*.

BatteryMode() (0x03)

Description: Selects the various battery operational modes and reports the battery's mode and requests.

Defined modes include

- Whether the battery capacity information is specified in units of mAh or 10 mWh (*CAPACITY_MODE* bit)
- Whether the *ChargingCurrent()* and *ChargingVoltage()* values are broadcast to the smart battery charger when the *CHARGER_MODE* bit is set.
- Whether all broadcasts to the smart battery charger and host are disabled

The defined request condition is the battery requesting a conditioning cycle (*RELEARN_FLAG*).

Purpose: The *CAPACITY_MODE* bit allows power management systems to best match their electrical characteristics with those reported by the battery. For example, a switching power supply represents a constant power load, whereas a linear supply is better represented by a constant current model. The *CHARGER_MODE* bit allows a SMBus host or smart battery charger to override the smart battery desired charging parameters by disabling the bq2084-V123 broadcasts. The *RELEARN_FLAG* bit allows the bq2084-V123 to request a conditioning cycle.

SMBus protocol: Read or write word

Input/Output: Unsigned integer—bit mapped—see below.

Units: Not applicable

Range: 0–1

Granularity: Not applicable

Accuracy: Not applicable

The *BatteryMode()* word is divided into two halves, the MSB (bits 8–15) which is read/write and the LSB (bits 0–7) which is read only. The bq2084-V123 forces bits 0–6 to zero and prohibits writes to bit 7.

Table 14 summarizes the meanings of the individual bits in the BatteryMode() word. Specified default values, where applicable, are noted. INTERNAL_CHARGE_CONTROLLER bit is not used by the bq2084-V123.

PRIMARY_BATTERY_SUPPORT bit is not used by the bq2084-V123.

RELEARN_FLAG bit set indicates that the bq2084-V123 is requesting a capacity relearn cycle for the battery. The bq2084-V123 sets the RELEARN_FLAG on a full reset and if it detects 20-cycle counts without an FCC update. The bq2084-V123 clears this flag after a learning cycle has been completed.

CHARGE_CONTROLLER_ENABLED bit is not used by the bq2084-V123. The bq2084-V123 forces this bit to zero.

PRIMARY_BATTERY bit is not used by the bq2084-V123. The bq2084-V123 forces this bit to zero.

Table 14. Battery Mode Bits and Values

BATTERY MODE() BITS	BITS USED	FORMAT	ALLOWABLE VALUES
INTERNAL_CHARGE_CONTROLLER	0	Read only bit flag	1 – always one
PRIMARY_BATTERY_SUPPORT	1	Read only bit flag	0 – always zero
Reserved	2–6		0 – always zero
RELEARN_FLAG	7	Read only bit flag	0—Battery OK 1—Relearn cycle requested
CHARGE_CONTROLLER_ENABLED	8	R/W bit flag	Not used
PRIMARY_BATTERY	9	R/W bit flag	Not used
Reserved	10–12		0 – always zero
ALARM_MODE	13	R/W bit flag	0—Enable alarm broadcast (default) 1—Disable alarm broadcast
CHARGER_MODE	14	R/W bit flag	0—Enable charging broadcast (default) 1—Disable charging broadcast
CAPACITY_MODE	15	R/W bit flag	0—Report in mA or mAh (default) 1—Report in 10 mW or 10 mWh

ALARM_MODE bit is set to disable the bq2084-V123s ability to master the SMBus and send AlarmWarning() messages to the SMBus host and the smart battery charger. When set, the bq2084-V123 does *not* master the SMBus, and AlarmWarning() messages are not sent to the SMBus host and the smart battery charger for a period of no more than 60 s and no less than 59 s. When cleared (default), the smart battery sends the AlarmWarning() messages to the SMBus host and the smart battery charger any time an alarm condition is detected.

- The ALARM broadcast does not occur more often than once every 10 s. Whenever the BATTERY_MODE command is received, the bq2084-V123 resets the bit and starts or restarts a 60-s (nominal) timer. After the timer expires, the bq2084-V123 automatically enables alarm broadcasts to ensure that the accidental deactivation of broadcasts does not persist. An SMBus host that does not want the bq2084-V123 to be a master on the SMBus must therefore continually set this bit at least once per 59 s to keep the bq2084-V123 from broadcasting alarms.
- The ALARM_MODE bit defaults to a cleared state when the bq2084-V123 enters SLEEP mode.
- The condition of the ALARM-MODE bit does *not* affect the operation or state of the CHARGER_MODE bit, which is used to prevent broadcasts of ChargingCurrent() and ChargingVoltage() to the smart battery charger. CHARGER_MODE bit enables or disables the bq2084-V123's transmission of ChargingCurrent() and ChargingVoltage() messages to the smart battery charger. When set, the bq2084-V123 does *not* transmit ChargingCurrent() and ChargingVoltage() values to the smart battery charger. When cleared, the bq2084-V123 transmits the ChargingCurrent() and ChargingVoltage() values to the smart battery charger. The CHARGER_MODE bit defaults to a cleared state when the bq2084-V123 enters SLEEP mode.

CAPACITY_MODE bit indicates if capacity information is reported in mA/mAh or 10 mW/10 mWh. When set, the bq2084-V123 reports capacity information in 10 mW/10 mWh as appropriate. When cleared, the bq2084-V123 reports capacity information in mA/mAh as appropriate. The CAPACITY_MODE bit defaults to a cleared state when the bq2084-V123 enters SLEEP mode.

The following functions are changed to accept or return values in mA/mAh or 10 mW/10 mWh depending on the CAPACITY_MODE bit:

- RemainingCapacityAlarm()
- AtRate()
- RemainingCapacity()
- FullChargeCapacity()
- DesignCapacity()

The following functions are calculated on the basis of capacity and may be calculated differently depending on the CAPACITY_MODE bit:

- AtRateOK()
- AtRateTimeToEmpty()
- AtRateTimeToFull()
- RunTimeToEmpty()
- AverageTimeToEmpty()
- AverageTimeToFull()
- Remaining Time Alarm()
- BatteryStatus()

The bq2084-V123 updates the non-AtRate related register values immediately after changing the state of the CAPACITY_MODE bit. The AtRate() values are updated after the next AtRate value is written to the bq2084-V123 (or after the next 1-s scheduled refresh calculation).

AtRate() (0x04)

Description: The AtRate() function is the first half of a two-function call-set used to set the AtRate value used in calculations made by the AtRateTimeToFull(), AtRateTimeToEmpty(), and AtRateOK() functions. The AtRate value may be expressed in either current (mA) or power (10 mW) depending on the setting of the BatteryMode() CAPACITY_MODE bit.

Purpose: Since the AtRate() function is the first half of a two-function call-set, it is followed by the second function of the call-set that calculates and returns a value based on the AtRate value and the battery's present state.

- When the AtRate() value is positive, the AtRateTimeToFull() function returns the predicted time to full-charge at the AtRate value of charge.
- When the AtRate() value is negative, the AtRateTimeToEmpty() function returns the predicted operating time at the AtRate value of discharge.
- When the AtRate() value is negative, the AtRateOK() function returns a Boolean value that predicts the battery's ability to supply the AtRate value of *additional* discharge energy (current or power) for 10 seconds.

The default value for AtRate() is zero.

SMBus protocol: Read or write word

Input/Output: Signed integer-charge or discharge; the AtRate() value is positive for charge, negative for discharge, and zero for neither (default).

	BATTERY MODES	
	CAPACITY_MODE BIT = 0	CAPACITY_MODE BIT = 1
Units	mA	10 mW
Charge range	1 to 32,767 mA	1 to 32,767 10 mW
Discharge range	-1 to -32,768 mA	-1 to -32,768 10 mW
Granularity	1 Unit	
Accuracy	NA	

AtRateTimeToFull() (0x05)

Description: Returns the predicted remaining time to fully charge the battery at the *AtRate()* value (mA).

Purpose: The *AtRateTimeToFull()* function is part of a two-function call-set used to determine the predicted remaining charge time at the *AtRate* value in mA. The bq2084-V123 updates *AtRateTimeToFull()* within 5 ms after the SMBus host sets the *AtRate* value. The bq2084-V123 automatically updates *AtRateTimeToFull()* based on the *AtRate()* value every 1 s.

SMBus protocol: Read word

Output: Unsigned integer—predicted time in minutes to fully charge the battery.

Units: Minutes

Range: 0 to 65,534 min

Granularity: 2 min or better

Accuracy: $\pm \text{MaxError}() * \text{FullChargeCapacity}() / |\text{AtRate}()|$

Invalid Data Indication: 65,535 indicates the *AtRate* = 0.

AtRateTimeToEmpty() (0x06)

Description: Returns the predicted remaining operating time if the battery is discharged at the *AtRate()* value.

Purpose: The *AtRateTimeToEmpty()* function is part of a two-function call-set used to determine the remaining operating time at the *AtRate()* value. The bq2084-V123 updates *AtRateTimeToEmpty()* within 5 ms after the SMBus host sets the *AtRate()* value. The bq2084-V123 automatically updates *AtRateTimeToEmpty()* based on the *AtRate()* value every 1 s.

SMBus protocol: Read word

Output: Unsigned integer—estimated operating time left.

Units: Minutes

Range: 0 to 65,534 min

Granularity: 2 min or better

Accuracy: $-0, +\text{MaxError}() \times \text{FullChargeCapacity} / |\text{AtRate}()|$

Invalid Data Indication: 65,535 indicates *AtRate* = 0.

AtRateOK() (0x07)

Description: Returns a Boolean value that indicates whether or not the battery can deliver the *AtRate()* value of *additional* energy for 10 s. If the *AtRate* value is zero or positive, the *AtRateOK()* function ALWAYS returns OK (logic 1).

Purpose: The *AtRateOK()* function is part of a two-function call-set used by power management systems to determine if the battery can safely supply enough energy for an additional load. The bq2084-V123 updates *AtRateOK()* within 5 ms after the SMBus host sets the *AtRate()* value. The bq2084-V123 automatically updates *AtRateOK()* based on the *AtRate()* value every 1 second.

SMBus protocol: Read word

Output: Boolean—indicates if the battery can supply the *additional* energy requested.

Units: Boolean

Range: 1, 0

Granularity: Not applicable

Accuracy: Not applicable

Temperature() (0x08)

Description: Returns the temperature (K) measured by the bq2084-V123.

Purpose: The *Temperature()* function provides accurate cell temperatures for use by battery chargers and thermal management systems. A battery charger can use the temperature as a safety check. Thermal management systems may use the temperature because the battery is one of the largest thermal sources in a system.

bq2084-V123

SLUS619A – AUGUST 2004 – REVISED JANUARY 2005

SMBus protocol: Read word

Output: Unsigned integer—cell temperature in tenth-degree Kelvin increments.

Units: 0.1°K

Range: 0 to +6553.5°K {real range}

Granularity: 0.1°K

Accuracy: ±1.5°K (from ideal Semitec 103AT thermistor performance, after calibration)

Voltage() (0x09)

Description: Returns the cell-pack voltage (mV).

Purpose: The Voltage() function provides power management systems with an accurate battery terminal voltage. Power management systems can use this voltage, along with battery current information, to characterize devices they control. This ability helps enable intelligent, adaptive power-management systems.

SMBus protocol: Read word

Output: Unsigned integer—battery terminal voltage in mV.

Units: mV

Range: 0 to 20,000 mV

Granularity: 1 mV

Accuracy: ±0.25% (after calibration)

Current() (0x0a)

Description: Returns the current being supplied (or accepted) by the battery (mA).

Purpose: The Current() function provides a snapshot for the power management system of the current flowing into or out of the battery. This information is of particular use in power-management systems because they can characterize individual devices and tune their operation to actual system power behavior.

SMBus protocol: Read word

Output: Signed integer—charge/discharge rate in mA increments: positive for charge, negative for discharge.

Units: mA

Range: –32,768 to 32,767 mA

Granularity: 1 mA

Accuracy: 0.25% or 5 mA, whichever is greater

AverageCurrent() (0x0b)

Description: Returns a value that approximates a one-minute rolling average of the current being supplied (or accepted) through the battery terminals (mA). AverageCurrent() is implemented as a single pole IIR filter with a 14.5-s time constant.

Purpose: The AverageCurrent() function provides the average current flowing into or out of the battery for the power management system.

SMBus protocol: Read word

Output: Signed integer—charge/discharge rate in mA increments: positive for charge, negative for discharge.

Units: mA

Range: –32,768 to 32,767 mA

Granularity: 1 mA

Accuracy: 0.25% or 5 mA, whichever is greater

MaxError() (0x0c)

Description: Returns the expected margin of error (%) in the state of charge calculation. For example, when MaxError() returns 10% and RelativeStateOfCharge() returns 50%, the Relative StateOfCharge() is more likely between 50% and 60%. The bq2084-V123 sets MaxError() to 100% on a full reset. The bq2084-V123

sets MaxError() to 2% on completion of a learning cycle, unless the bq2084-V123 limits the learning cycle to the +512/-256 mAh maximum adjustment values. If the learning cycle is limited, the bq2084-V123 sets MaxError() to 8% unless MaxError() was already below 8%. In this case, MaxError() does not change. The bq2084-V123 increments MaxError() by 1% after four increments of CycleCount() without a learning cycle. If voltage-based corrections are applied to the coulomb counter, MaxError() is set to 25%.

Purpose: The MaxError() function has real value in two ways: first, to give the user a confidence level about the state of charge and second, to give the power management system information about how aggressive it should be, particularly as the battery nears the end of its life.

SMBus protocol: Read word

Output: Unsigned integer—percent uncertainty for selected information.

Units: %

Range: 2–100%

Granularity: 1%

Accuracy: Not applicable

RelativeStateOfCharge() (0x0d)

Description: Returns the predicted remaining battery capacity expressed as a percentage of FullChargeCapacity() (%).

Purpose: The RelativeStateOfCharge() function is used to estimate the amount of charge remaining in the battery relative to the last learned capacity.

SMBus protocol: Read word

Output: Unsigned integer-percent of remaining capacity.

Units: %

Range: 0–100%

Granularity: 1%

Accuracy: -0, +MaxError()

AbsoluteStateOfCharge() (0x0e)

Description: Returns the predicted remaining battery capacity expressed as a percentage of DesignCapacity() (%). Note that AbsoluteStateOfCharge() can return values greater than 100%.

Purpose: The AbsoluteStateOfCharge() function is used to estimate the amount of charge remaining in the battery relative to the nominal or DesignCapacity().

SMBus protocol: Read word

Output: Unsigned integer—percent of remaining capacity.

Units: %

Range: 0–100+%

Granularity: 1%

Accuracy: -0, +MaxError()

RemainingCapacity() (0x0f)

Description: Returns the predicted charge or energy remaining in the battery. The RemainingCapacity() value is expressed in either charge or energy, depending on the setting of the BatteryMode() CAPACITY_MODE bit.

Purpose: The RemainingCapacity() function returns the battery's remaining capacity. This information is a numeric indication of remaining charge or energy given by the Absolute or Relative StateOfCharge() functions and may be in a better form for use by power management systems.

SMBus protocol: Read word

Output: Unsigned integer—remaining charge in units of mAh or 10 mWh.

	BATTERY MODES	
	CAPACITY_MODE BIT = 0	CAPACITY_MODE BIT = 1
Units	mAh	10 mWh
Range	0–65,535 mAh	0–65,535 10 mWh
Granularity	mAh	10 mWh
Accuracy	–0, +MaxError() *	FullChargeCapacity()

FullChargeCapacity() (0x10)

Description: Returns the predicted pack capacity when it is fully charged. The FullChargeCapacity() value is expressed in either current (mAh at a C/5 discharge rate) or power (10 mWh at a P/5 discharge rate) depending on the setting of the BatteryMode() CAPACITY_MODE bit.

Purpose: The FullChargeCapacity() function provides a means of understanding the tank size of the battery. This information, along with information about the original capacity of the battery, indicates battery wear.

SMBus protocol: Read word

Output: Unsigned integer—estimated full-charge capacity in units of mAh or 10 mWh.

	BATTERY MODES	
	CAPACITY_MODE BIT = 0	CAPACITY_MODE BIT = 1
Units	mAh	10 mWh
Range	0–65,535 mAh	0–65,535 10 mWh
Granularity	mAh	10 mWh
Accuracy	–0, +MaxError() × FullChargeCapacity()	

RunTimeToEmpty() (0x11)

Description: Returns the predicted remaining battery life at the present rate of discharge (minutes). TheRunTimeToEmpty() value is calculated based on either current or power depending on the setting of theBatteryMode() CAPACITY_MODE bit.

Purpose: The RunTimeToEmpty() provides the power management system with information about the relative gain or loss in remaining battery life in response to a change in power policy. This information is **not** the same as the AverageTimeToEmpty(), which is not suitable to determine the effects that result from a change in power policy.

SMBus protocol: Read word

Output: Unsigned integer—minutes of operation left.

Units: Minutes

Range: 0 to 65,534 min

Granularity: 2 min or better

Accuracy: –0, +MaxError() × FullChargeCapacity() / Current()

Invalid Data Indication: 65,535 indicates battery is not being discharged.

AverageTimeToEmpty() (0x12)

Description: Returns a predicted remaining battery life (minutes), based on AverageCurrent. TheAverageTimeToEmpty() value is calculated based on either current or power depending on the setting of the BatteryMode() CAPACITY_MODE bit.

Purpose: The AverageTimeToEmpty() displays state-of-charge information in a more useful way. It averages the instantaneous estimations so the remaining time does not appear to jump around.

SMBus protocol: Read word

Output: Unsigned integer—minutes of operation left.

Units: Minutes

Range: 0 to 65,534 min

Granularity: 2 min or better

Accuracy: $-0, +\text{MaxError}() * \text{FullChargeCapacity}() / \text{AverageCurrent}()$

Invalid Data Indication: 65,535 indicates battery is not being discharged.

AverageTimeToFull() (0x13)

Description: Returns a predicted remaining time until the battery reaches full charge (minutes), based on AverageCurrent.

Purpose: The AverageTimeToFull() function can be used by the SMBus host's power management system to aid in its policy. It may also be used to find out how long the system must be left on to achieve full charge.

SMBus protocol: Read word

Output: Unsigned integer—remaining time in minutes.

Units: Minutes

Range: 0 to 65,534 minutes

Granularity: 2 minutes or better

Accuracy: $-0, +\text{MaxError}() * \text{FullChargeCapacity}() / \text{AverageCurrent}()$

Invalid Data Indication: 65,535 indicates the battery is not being charged.

ChargingCurrent() (0x14)

Description: Returns the desired charging rate in mA.

Purpose: The ChargingCurrent() function sets the maximum charge current of the battery. TheChargingCurrent() value should be used in combination with the ChargingVoltage() value to set the charger's operating point. Together, these functions permit the bq2084-V123 to dynamically control the charging profile (current/voltage) of the battery. The bq2084-V123 can effectively turn off a charger by returning a value of 0 for this function. The charger may be operated as a constant-voltage source above its maximum regulated current range by returning a ChargingCurrent() value of 65,535.

SMBus protocol: Read word

Output: Unsigned integer—maximum charger output current in mA.

Units: mA

Range: 0 to 65,535 mA

Granularity: 1 mA

Accuracy: Not applicable

Invalid Data Indication: 65,535 indicates that a charger should operate as a voltage source outside its maximum regulated current range.

ChargingVoltage() (0x15)

Description: Returns the desired charging voltage in mV.

Purpose: The ChargingVoltage() function sets the maximum charge voltage of the battery. The ChargingVoltage() value should be used in combination with the ChargingCurrent() value to set the charger's operating point. Together, these functions permit the bq2084-V123 to dynamically control the charging profile (current/voltage) of the battery. The charger may be operated as a constant-current source above its maximum regulated voltage range by returning a ChargingVoltage() value of 65,535.

SMBus protocol: Read word

Output: Unsigned integer—charger output voltage in mV.

Units: mV

Range: 0 to 65,535 mV

bq2084-V123

SLUS619A – AUGUST 2004 – REVISED JANUARY 2005

Granularity: 1 mV

Accuracy: Not applicable

Invalid Data Indication: 65,535 indicates the charger should operate as a current source outside its maximum regulated voltage range.

BatteryStatus() (0x16)

Description: Returns the bq2084-V123 status word (flags). Some of the BatteryStatus() flags (REMAINING_CAPACITY_ALARM and REMAINING_TIME_ALARM) are calculated on the basis of either current or power depending on the setting of the BatteryMode() CAPACITY_MODE bit. This is important because use of the wrong calculation mode may result in an inaccurate alarm.

Purpose: The BatteryStatus() function is used by the power management system to get alarm and status bits, as well as error codes from the bq2084-V123. This is basically the same information broadcast to both the SMBus host and the smart battery charger by the AlarmWarning() function except that the AlarmWarning() function sets the error code bits all high before sending the data.

SMBus protocol: Read word

Output: Unsigned Integer-status register with alarm conditions bit mapped as follows:

ALARM BITS	
0x8000	OVER_CHARGED_ALARM
0x4000	TERMINATE_CHARGE_ALARM
0x2000	Reserved
0x1000	OVER_TEMP_ALARM
0x0800	TERMINATE_DISCHARGE_ALARM
0x0400	Reserved
0x0200	REMAINING_CAPACITY_ALARM
0x0100	REMAINING_TIME_ALARM
STATUS BITS	
0x0080	Initialized
0x0040	DISCHARGING
0x0020	FULLY_CHARGED
0x0010	FULLY_DISCHARGED
ERROR CODES	
0x0007	Unknown Error
0x0006	BadSize
0x0005	Overflow/Underflow
0x0004	AccessDenied
0x0003	UnsupportedCommand
0x0002	ReservedCommand
0x0001	Busy
0x0000	OK

Alarm Bits

OVER_CHARGED_ALARM bit is set whenever the bq2084-V123 detects that the battery is being charged beyond the maximum overcharge limit, which is full capacity plus *Maximum Overcharge* DF 0x51-0x52. This bit is cleared when the bq2084-V123 detects that the battery is no longer being charged and there are 2 mAH of continuous discharge (i.e., the bq2084-V123 detects discharge activity or no activity above the digital filter).

TERMINATE_CHARGE_ALARM bit is set when the bq2084-V123 detects a primary charge termination. This bit is cleared when the bq2084-V123 detects that the battery is no longer being charged.

OVER_TEMP_ALARM bit is set when the bq2084-V123 detects that the internal battery temperature is greater than or equal to the *OverTemperature Charge* threshold while charging or *OverTemperature Discharge* threshold while discharging. This bit is cleared when the internal temperature falls back below the *OverTemperature Charge Reset* or *OverTemperature Discharge Reset* as appropriate..

TERMINATE_DISCHARGE_ALARM bit is set when $RM = 0$, $Voltage() = \textit{Terminate Voltage DF 0x67-0x68}$, the battery temperature is less than or equal to the *Charge Suspend Temp Low* DF 0x79 or the CVUV bit in pack status is set indicating that a Li-Ion cell voltage has dropped below the limit programmed in *Cell Under*. The bit is cleared when $Voltage() > \textit{Terminate Voltage}$, $RM() > 0$, and the CVUV bit is cleared.

REMAINING_CAPACITY_ALARM bit is set when the bq2084-V123 detects that $RemainingCapacity()$ is less than that set by the $RemainingCapacityAlarm()$ function. This bit is cleared when either the value set by the $RemainingCapacityAlarm()$ function is lower than the $RemainingCapacity()$ or when the $RemainingCapacity()$ is increased by charging.

REMAINING_TIME_ALARM bit is set when the bq2084-V123 detects that the estimated remaining time at the present discharge rate is less than that set by the $RemainingTimeAlarm()$ function. This bit is cleared when either the value set by the $RemainingTimeAlarm()$ function is lower than the $AverageTimeToEmpty()$ or when the $AverageTimeToEmpty()$ is increased by charging.

Status Bits

The initialized bit is set when the bq2084-V123 has detected a valid load of data flash at full or partial reset. It is cleared when the bq2084-V123 detects an improper data flash load.

DISCHARGING bit is set when the bq2084-V123 determines that the battery is not being charged. This bit is cleared when the bq2084-V123 detects that the battery is being charged.

FULLY_CHARGED bit is set when the bq2084-V123 detects a primary charge termination or an Overcharge condition. It is cleared when $RelativeStateOfCharge()$ is less than the programmed *Fully Charged Clear %* in DF 0x4a.

FULLY_DISCHARGED bit is set when $Voltage()$ or VCELL is less than the EDV2 threshold and $Current() < \textit{Overload Current}$ or when $RelativeStateOfCharge() < \textit{Battery Low \%}$. This bit is cleared when $RelativeStateOfCharge()$ is greater than or equal to 20%.

Error Codes

ERROR CODES	DESCRIPTION
OK	The bq2084-V123 processed the function code without detecting any errors.
Busy	The bq2084-V123 is unable to process the function code at this time.
Reserved	The bq2084-V123 detected an attempt to read or write to a function code reserved by this version of the specification. The bq2084-V123 detected an attempt to access an unsupported optional manufacturer function code.
Unsupported	The bq2084-V123 does not support this function code which is defined in this version of the specification.
AccessDenied	The bq2084-V123 detected an attempt to write to a read-only function code.
Over/Underflow	The bq2084-V123 detected a data overflow or underflow.
BadSize	The bq2084-V123 detected an attempt to write to a function code with an incorrect data block.
UnknownError	The bq2084-V123 detected an unidentifiable error.

bq2084-V123

SLUS619A – AUGUST 2004 – REVISED JANUARY 2005

CycleCount() (0x17)

Description: Returns the number of cycles the battery has experienced. The mAh value of each count is determined by programming the *Cycle Count Threshold* value in DF 0x38–0x39. The bq2084-V123 saves the cycle count value to *Cycle Count* DF 0x0c–0x0d after an update to CycleCount().

Purpose: The CycleCount() function provides a means to determine the battery wear. It may be used to give advance warning that the battery is nearing its end of life.

SMBus protocol: Read word

Output: Unsigned integer—count of total charge removed from the battery over its life.

Units: cycle

Range: 0 to 65,534 cycles; 65,535 indicates battery has experienced 65,535 or more cycles.

Granularity: 1 cycle

Accuracy: Absolute count

DesignCapacity() (0x18)

Description: Returns the theoretical or nominal capacity of a new pack. The DesignCapacity() value is expressed in either current (mAh at a C/5 discharge rate) or power, (10 mWh at a P/5 discharge rate) depending on the setting of the BatteryMode() CAPACITY_MODE bit.

Purpose: The DesignCapacity() function is used by the SMBus host's power management in conjunction with FullChargeCapacity() to determine battery wear. The power management system may present this information to the user and also adjust its power policy as a result.

SMBus protocol: Read word

Output: Unsigned integer—battery capacity in units of mAh or 10 mWh.

	BATTERY MODES	
	CAPACITY_MODE BIT = 0	CAPACITY_MODE BIT = 1
Units	mAh	10 mWh
Range	0–65,535 mAh	0–65,535 10 mWh
Granularity	Not applicable	Not applicable
Accuracy	Not applicable	Not applicable

DesignVoltage() (0x19)

Description: Returns the theoretical voltage of a new pack (mV). The bq2084-V123 sets DesignVoltage() to the value programmed in *Design Voltage* DF 0x04–0x05.

Purpose: The DesignVoltage() function can be used to give additional information about a particular smart battery expected terminal voltage.

SMBus protocol: Read word

Output: Unsigned integer—the battery's designed terminal voltage in mV

Units: mV

Range: 0 to 65,535 mV

Granularity: Not applicable

Accuracy: Not applicable

SpecificationInfo() (0x1a)

Description: Returns the version number of the smart battery specification the battery pack supports, as well as voltage and current scaling information in a packed unsigned integer. Power scaling is the product of the voltage scaling times the current scaling. The SpecificationInfo() is packed in the following fashion:

$$(\text{SpecID_H} \times 0x10 + \text{SpecID_L}) + (\text{VScale} + \text{IPScale} \times 0x10) \times 0x100.$$

The bq2084-V123 VScale (voltage scaling) and IPScale (current scaling) should always be set to zero. The bq2084-V123 sets SpecificationInfo() to the value programmed in *Specification Information* DF 0x06–0x07.

Purpose: The SpecificationInfo() function is used by the SMBus host's power management system to determine what information the smart battery can provide.

SMBus protocol: Read word

Output: Unsigned integer—packed specification number and scaling information:

FIELD	BITS USED	FORMAT	ALLOWABLE VALUES
SpecID_L	0...3	4-bit binary value	0–15
SpecID_H	4...7	4-bit binary value	0–15
VScale	8...11	4-bit binary value	0 (multiplies voltage by 10 [^] VScale)
IPScale	12...15	4-bit binary value	0 (multiplies current by 10 [^] IPScale)

ManufactureDate() (0x1b)

Description: This function returns the date the cell pack was manufactured in a packed integer. The date is packed in the following fashion: (year–1980) * 512 + month * 32 + day. The bq2084–V123 sets ManufactureDate() to the value programmed in *Manufacture Date* DF 0x08–0x09.

Purpose: The ManufactureDate() provides the system with information that can be used to uniquely identify a particular battery pack when used in conjunction with SerialNumber().

SMBus protocol: Read word

Output: Unsigned integer-packed date of manufacture:

FIELD	BITS USED	FORMAT	ALLOWABLE VALUES
Day	0..4	5-bit binary value	0–31 (corresponds to date)
Month	5..8	4-bit binary value	1–12 (corresponds to month number)
Year	9...15	7-bit binary value	0–127 (corresponds to year biased by 1980)

SerialNumber() (0x1c)

Description: This function is used to return a serial number. This number, when combined with the ManufacturerName(), the DeviceName(), and the ManufactureDate(), uniquely identifies the battery (unsigned integer). The bq2084–V123 sets SerialNumber() to the value programmed in *Serial Number* DF 0x0a–0x0b.

Purpose: The SerialNumber() function can be used to identify a particular battery. This may be important in systems that are powered by multiple batteries where the system can log information about each battery that it encounters.

SMBus protocol: Read word

Output: Unsigned integer

ManufacturerName() (0x20)

Description: This function returns a character array containing the battery manufacturer's name. For example, MyBattCo identifies the smart battery manufacturer as MyBattCo. The bq2084–V123 sets ManufacturerName() to the value programmed in *Manufacturer Name* DF 0x0e–0x19.

Purpose: The ManufacturerName() function returns the name of the smart battery manufacturer. The manufacturer's name can be displayed by the SMBus host's power management system display as both an identifier and as an advertisement for the manufacturer. The name is also useful as part of the information required to uniquely identify a battery.

SMBus protocol: Read block

Output: String—character string with maximum length of 11 characters (11 + length byte).

bq2084-V123

SLUS619A – AUGUST 2004 – REVISED JANUARY 2005

DeviceName() (0x21)

Description: This function returns a character string that contains the battery name. For example, a DeviceName() of bq2084-V123 indicates that the battery is a model bq2084-V123. The bq2084-V123 sets DeviceName() to the value programmed in *Device Name* DF 0x1a-0x21.

Purpose: The DeviceName() function returns the battery name for identification purposes.

SMBus protocol: Read block

Output: String—character string with maximum length of 7 characters (7 + length byte).

DeviceChemistry() (0x22)

Description: This function returns a character string that contains the battery chemistry. For example, if the DeviceChemistry() function returns *NiMH*, the battery pack contains nickel metal hydride cells. The bq2084-V123 sets DeviceChemistry() to the value programmed in *Device Chemistry* DF 0x22-0x26.

Purpose: The DeviceChemistry() function gives cell chemistry information for use by charging systems. The bq2084-V123 does not use DeviceChemistry() values for internal charge control or fuel gauging.

SMBus protocol: Read block

Output: String—character string with maximum length of 4 characters (4 + length byte).

The following is a partial list of chemistries and their expected abbreviations. These abbreviations are *not* case sensitive.

CHEMISTRY	ABBREVIATIONS
Lead acid	PbAc
Lithium ion	LION
Nickel cadmium	NiCd
Nickel metal hydride	NiMH
Nickel zinc	NiZn
Rechargeable alkaline-manganese	RAM
Zinc air	ZnAr

The ManufacturerData() (0x23)

Description: This function allows access to the manufacturer data contained in the battery (data). The bq2084-V123 stores seven critical operating parameters in this data area.

Purpose: The ManufacturerData() function may be used to access the manufacturer's data area. The data fields of this command reflect the programming of eight critical data flash locations and can be used to facilitate evaluation of the bq2084-V123 under various programming sets. The ManufacturerData() function returns the following information in order: *Pack Configuration*, *Gauge Configuration*, *Misc Configuration (2 bytes)*, *Digital Filter*, *Self Discharge Rate*, *Pack Load Estimate*, *Battery Low%*, and *Near Full (2 bytes) AFE Status*, and the pending EDV threshold voltage (low byte and high byte).

SMBus protocol: Read block

Output: Block data—data that reflects data flash programming as assigned by the manufacturer with maximum length of 13 characters (13 + length byte).

Pack Status and Pack Configuration (0x2f)

This function returns the pack status and pack configuration registers. The pack status register contains a number of status bits relating to bq2084-V123 operation. The pack status register is the least significant byte of the word. The pack configuration register reflects how the bq2084-V123 is configured as defined by the value programmed in *Pack Configuration* in DF 0x28.

The pack status register consists of the following bits:

b7	b6	b5	b4	b3	b2	b1	b0
PRES	EDV2	SS	VDQ	AFEFAIL	PF	CVOV	CVUV

PRES

The PRES bit indicates that the bq2084-V123 has been inserted into the system.

- 0 bq2084-V123 is out of the system
- 1 bq2084-V123 is inserted into a system

EDV2

The EDV2 bit indicates that pack or cell voltage (program option) is less than the EDV2 threshold.

- 0 Voltage > EDV2 threshold (discharging)
- 1 Voltage = EDV2 threshold

SS

The SS bit indicates the seal state of the bq2084-V123.

- 0 The bq2084-V123 is in the unsealed state
- 1 The bq2084-V123 is in the sealed state

AFEFAIL

The AFEFAIL bit indicates that AFE communications has failed.

- 0 AFE communications okay
- 1 AFE communications have failed

VDQ

The VDQ bit indicates if the present discharge cycle is valid for an FCC update.

- 0 Discharge cycle not valid
- 1 Discharge cycle valid

PF

The PF bit indicates that the bq2084-V123 *PF Flag* has been set. It is cleared only when the *PF Flag* has been cleared

- 0 bq2084-V123 *PF Flag* = 0x00
- 1 bq2084-V123 *PF Flag* = 0x66

CVOV

The CVOV bit indicates that a protection limit has been exceeded including Prolonged Overcurrent, Overvoltage, or Overtemperature conditions. The bit is not latched and merely reflects the present fault status.

- 0 No secondary protection limits exceeded
- 1 A secondary protection limit exceeded

CVUV

The CVUV bit indicates that a protection limit has been exceeded including overload or overdischarge conditions. The bit is not latched and merely reflects the present fault status.

- 0 No secondary protection limits exceeded
- 1 A secondary protection limit exceeded

bq2084-V123

SLUS619A – AUGUST 2004 – REVISED JANUARY 2005

VCELL4-VCELL1 (0x3c-0x3f)

These functions return the calculated individual cell voltages in mV.

Data Flash

General

The bq2084-V123 accesses the internal data flash during reset and when storing historical data. The data flash stores basic configuration information for use by the bq2084-V123. The data flash must be programmed correctly for proper bq2084-V123 operation.

Memory Map

The following table shows the memory map for the data flash. It shows the default programming for the bq2084-V123. The default programming reflects example data for a 3s2p Li-Ion battery pack with a 0.02-Ω sense resistor. The data flash must be reprogrammed to meet the requirements of individual applications.

DATA FLASH ADDRESS		NAME	LI-ION EXAMPLE	DATA	
HIGH BYTE	LOW BYTE			MSB	LSB
0x00	0x01	<i>Remaining Time Alarm</i>	10 minutes	00	0a
0x02	0x03	<i>Remaining Capacity Alarm</i>	360 mAh	01	68
0x04	0x05	<i>Design Voltage</i>	14400 mV	38	40
0x06	0x07	<i>Specification Information</i>	v1.1/PEC	00	31
0x08	0x09	<i>Manufacture Date</i>	1/1/2003=11809	2e	21
0x0a	0x0b	<i>Serial Number</i>	1	00	01
0x0c	0x0d	<i>Cycle Count</i>	0	00	00
0x0e		<i>Manufacturer Name Length</i>	11		0b
0x0f		Character 1	T		54
0x10		Character 2	e		45
0x11		Character 3	x		58
0x12		Character 4	a		41
0x13		Character 5	s		53
0x14		Character 6			20
0x15		Character 7	l		49
0x16		Character 8	n		4e
0x17		Character 9	s		53
0x18		Character 10	t		54
0x19		Character 11	.		2e
0x1a		<i>Device Name Length</i>	6		06
0x1b		Character 1	b		42
0x1c		Character 2	q		51
0x1d		Character 3	2		32
0x1e		Character 4	0		30
0x1f		Character 5	8		38
0x20		Character 6	4		34
0x21		Character 7	—		00
0x22		<i>Device Chemistry Length</i>	4		04
0x23		Character 1	L		4c
0x24		Character 2	l		49
0x25		Character 3	O		4f
0x26		Character 4	N		4e
0x27		<i>Manufacturer Data Length</i>	9		09
0x28		<i>Pack Configuration</i>	DMODE, 4-LEDs, 4-CELL		c3
0x29		<i>Gauge Configuration</i>	CSYNC, OTVC		41

DATA FLASH ADDRESS		NAME	LI-ION EXAMPLE	DATA	
HIGH BYTE	LOW BYTE			MSB	LSB
0x2a	0x2b	Misc Configuration	OT, VOD	0b	00
0x2c		Digital Filter (Dead Band)	9860 nV		22
0x2d		Self-Discharge Rate	0.2%		14
0x2e		Electronics Load	0 mA		00
0x2f		Battery Low % (MSB)	7.03%		12
0x30	0x31	Near Full	200 mAh	00	c8
0x32	0x33	Design Capacity	7200 mAh	1c	20
0x34	0x35	Reserved	0	00	00
0x36	0x37	Full Charge Capacity	7200 mAh	1c	20
0x38	0x39	Cycle Count Threshold	5200 mAh	14	50
0x3a	0x3b	Charging Voltage	16800 mV	41	a0
0x3c	0x3d	Precharge Voltage	2500 mV	09	c4
0x3e	0x3f	Fast-Charging Current	2500 mA	09	c4
0x40	0x41	Maintenance Charging Current	0 mA	00	00
0x42	0x43	Precharge Current	100 mA	00	64
0x44		Precharge Temperature	9.6°C		60
0x45		Precharge Temperature Hysteresis	3.0°C		1e
0x46		Charge Inhibit Temp Low	0.0°C		00
0x47	0x48	Charge Inhibit Temp High	50.0°C	01	f4
0x49		Fast Charge Termination %	100%		ff
0x4a		Fully Charged Clear %	95%		5f
0x4b	0x4c	Current Taper Threshold	240 mA	00	f0
0x4d	0x4e	Current Taper Qual Voltage	300 mV	01	2c
0x4f		Current Taper Window	40s		28
0x50		Reserved			40
0x51	0x52	Maximum Overcharge	300 mAh	01	2c
0x53		Reserved			02
0x54		Charge Efficiency	100%		ff
0x55		Reserved			64
0x56	0x57	Reserved		02	22
0x58		Reserved			32
0x59	0x5a	Reserved		01	ae
0x5b	0x5c	Overload Current	5000 mA	13	88
0x5d	0x5e	Over Voltage Margin	700 mV	02	bc
0x5f	0x60	Reserved		01	f4
0x61	0x62	Clear Fail Current	256 mA	01	00
0x63	0x64	Cell Over Voltage	4350 mV	10	fe
0x65	0x66	Cell Under Voltage	2300 mV	08	fc
0x67	0x68	Terminate Voltage	11300 mV	2c	24
0x69	0x6a	Reserved		00	00
0x6b	0x6c	Safety Over Voltage	15000 mV	3a	98
0x6d	0x6e	Charge Suspend Temp High	60°C	02	58
0x6f	0x70	Charge Suspend Temp High Reset	55°C	02	26
0x71	0x72	Over Temperature Discharge	70°C	02	bc
0x73	0x74	Over Temperature Discharge Reset	60°C	02	58
0x75	0x76	Safety OverTemperature Charge	75°C	02	ee

bq2084-V123

SLUS619A – AUGUST 2004 – REVISED JANUARY 2005

DATA FLASH ADDRESS		NAME	LI-ION EXAMPLE	DATA	
HIGH BYTE	LOW BYTE			MSB	LSB
0x77	0x78	<i>Safety OverTemperature Discharge</i>	75°C	02	ee
0x79		<i>Charge Suspend Temp Low</i>	0°C		00
0x7a		Reserved			ef
0x7b		<i>Current Deadband</i>	3 mA		03
0x7c	0x7d	<i>Shutdown Voltage</i>	8800 mV	22	60
0x7e	0x7f	<i>VOC75</i>	15848 mV	3d	e8
0x80		Reserved			bf
0x81		Reserved			56
0x82		Reserved			40
0x83	0x84	<i>VOC50</i>	15240 mV	3b	88
0x85		Reserved			7f
0x86		Reserved			3d
0x87		Reserved			27
0x88	0x89	<i>VOC25</i>	15024 mV	3a	b0
0x8a		Reserved			3f
0x8b		Reserved			24
0x8c		Reserved			0e
0x8d		Reserved			14
0x8e		<i>Voltage Average Time</i>	1 s		01
0x8f		<i>Correction Current Limit</i>	64 mA		40
0x90	0x91	Reserved		0b	e1
0x92	0x93	Reserved		0b	68
0x94		Reserved			19
0x95	0x96	<i>EMF/EDV0</i>	3000 mV	0b	b8
0x97	0x98	<i>EDV C0 Factor/EDV1</i>	3250 mV	0c	b2
0x99	0x9a	<i>EDV R0 Factor/EDV2</i>	3400 mV	0d	48
0x9b	0x9c	<i>EDV T0 Factor</i>	0	00	00
0x9d	0x9e	<i>EDV R1 Factor</i>	0	00	00
0x9f		<i>EDV TC Factor</i>	0		00
0xa0		<i>EDV C1 Factor</i>	0		00
0xa1		Reserved			08
0xa2		Reserved			9b
0xa3		Reserved			c7
0xa4		Reserved			64
0xa5		Reserved			14
0xa6	0xa7	Reserved		02	00
0xa8	0xa9	Reserved		01	00
0xaa		Reserved			08
0xab		Reserved			02
0xac		<i>Learning Low Temp</i>	11.9°C		77
0xad		Reserved			0a
0xae	0xaf	Reserved		01	80
0xb0	0xb1	Reserved		01	00
0xb2		Reserved			08
0xb3		Reserved			18
0xb4		Reserved			14

DATA FLASH ADDRESS		NAME	LI-ION EXAMPLE	DATA	
HIGH BYTE	LOW BYTE			MSB	LSB
0xb5	0xb6	TS Const 1	91	83	
0xb7	0xb8	TS Const 2	51	70	
0xb9	0xba	TS Const 3	e2	8f	
0xbb	0xcc	TS Const 4	0f	ac	
0xbd	0xce	TS Const 5	00	00	
0xbf	0xc0	Reserved	0f	ac	
0xc1		Reserved		02	
0xc2		<i>AFE State Control</i>		00	
0xc3		<i>AFE Function Control</i>		00	
0xc4		<i>AFE Cell Select</i>		00	
0xc5		<i>AFE Overload</i>	140 mV	12	
0xc6		<i>AFE Overload Delay</i>	31 ms	0f	
0xc7		<i>AFE Short Circuit Charge</i>		17	
0xc8		<i>AFE Short Circuit Discharge</i>		17	
0xc9	0xca	<i>AFE Vref*</i>	9750 mV	26 16	
0xcb	0xcc	<i>Sense Resistor Gain*</i>	0.02 &	3b d0	
0xcd	0xce	<i>CC Delta*</i>	0.0000323 mAh	92 0a	
0xcf	0xd0	<i>CC Delta*</i>		16 00	
0xd1		Reserved		fa	
0xd2	0xd3	<i>CC Offset*</i>	49701	c2 25	
0xd4		<i>DSC Offset*</i>	38	26	
0xd5		<i>ADC Offset*</i>	38	26	
0xd6		<i>Temperature Offset*</i>	0	00	
0xd7		<i>Board Offset*</i>	0	00	
0xd8	0xd9	Reserved	00	40	
0xda	0xdb	Reserved	01	00	
0xdc		Reserved		05	
0xdd	0xde	Version	1.0	01 00	
0xdf		Reserved		00 32	
0xe0	0xe1	<i>Cell Over Voltage Reset</i>	4150 mV	10 36	
0xe2	0xe3	<i>Cell Under Voltage Reset</i>	3000 mV	0b b8	
0xe4	0xe5	<i>AFE Fail Limit</i>	2 counts	00 02	
0xe6	0xe7	Reserved		ff ff	
0xe8	0xe9	<i>Cell Balance Thresh</i>	3900 mV	0f 3c	
0xea	0xeb	<i>Cell Balance Window</i>	100 mV	00 64	
0xec		<i>Cell Balance Min</i>	40 mV	28	
0xed		<i>Cell Balance Interval</i>	20 s	14	
0xee	0xef	<i>Cell Imbalance Threshold</i>		01 f4	
0xf0	0xf1	<i>Balance Vcell Max</i>		10 36	
0xf2	0xf3	<i>Balance I_{max}</i>		00 9e	
0xf4	0xf5	Reserved		a5 5a	
0xf6	0xf7	Reserved		7a 43	
0xf8	0xf9	Reserved		20 83	
0xfa		<i>Battery Low (LSB)</i>	7.03 %	12	
0xfb		<i>AFE Check Time</i>	0 s	00	
0xfc		<i>Sleep Current Thresh</i>	2 mA	04	

bq2084-V123

SLUS619A – AUGUST 2004 – REVISED JANUARY 2005

DATA FLASH ADDRESS		NAME	LI-ION EXAMPLE	DATA	
HIGH BYTE	LOW BYTE			MSB	LSB
0xfd		<i>Sleep Current Multiplier</i>	5 counts		05
0xfe		<i>Sleep Time</i>	20 s		14
0xff	0x100	<i>Manufacturer Info 1</i>		00	00
0x101	0x102	<i>Manufacturer Info 2</i>		00	00
0x103	0x104	<i>Manufacturer Info 3</i>		00	00
0x105	0x106	<i>Vmax Charge Voltage</i>	4280 mv	10	b8
0x107	0x108	<i>Voff Charge Voltage</i>	4280 mv	10	b8
0x109	0x10a	<i>Von Charge Voltage</i>	4200 mv	10	68
0x10b	0x10c	<i>Pulse Max On Time</i>	60 s	01	e0
0x10d	0x10e	<i>Pulse Min Off Time</i>	0.125 s	00	01
0x10f	0x110	<i>Max Charge Time</i>	7200 s	1c	20
0x111	0x112	<i>Precharge Detection Current</i>	10 mA	00	0a
0x113	0x114	<i>Charge Detection Current</i>	100 mA	00	64
0x115	0x116	<i>Discharge Detection Current</i>	-150 mA	ff	6a
0x117	0x118	Reserved		10	68
0x119	0x11a	Reserved		10	36
0x11b	0x11c	Reserved			00
0x11d		<i>Permanent Fail Status</i>	0		00
0x11e		<i>Permanent Fail Flag</i>	0		00
0x11f		<i>Permanent Fail Config</i>	0		00
0x120		<i>Permanent Fail Input Time</i>	0		00
0x121	0x122	Reserved		17	12
0x123	0x124	Reserved		26	73
0x125	0x126	<i>FET Fail Charge Current</i>	20 mA	00	20
0x127	0x128	<i>FET Fail Discharge Current</i>	-20 mA	ff	ec
0x129		<i>FET Fail Time</i>	20 s		14
0x12a	0x12b	<i>Charge OC Threshold</i>	4000 mA	0f	a0
0x12c		<i>Charge OC Time</i>	6 s		06
0x12d	0x12e	<i>Discharge OC Threshold</i>	10970 mA	2a	da
0x12f		<i>Discharge OC Time</i>	10 s		00
0x130		<i>Fault Reset Time</i>	30 s		1e
0x131	0x132	<i>VPACK Threshold</i>		07	d0
0x133		<i>Shutdown Timer</i>	20 s		14
0x134		<i>Cell Imbalance Time</i>	20 s		14
0x135	0x136	Reserved			

NOTE: Reserved locations must be set as shown. Locations marked with an * are typical calibration values that can be adjusted for maximum accuracy. For these locations the table shows the appropriate default or initial setting.

ADDITIONAL PROGRAMMING INFORMATION

Additional Data Flash Programming

The following sections describe the function of each data flash location and how the data is to be stored.

Fundamental Parameters

Sense Resistor Value

The 32-bit *CC Delta* DF 0xcd–0xd0 corrects the coulomb counter for sense resistor variations. It represents the gain factor for the coulomb counter. The 16-bit *Sense Resistor Gain* in DF 0xcb–0xcc scales each integrating converter conversion to mAh. The Current() related measurement *Sense Resistor Gain* is based on the resistance of the series sense resistor. The following formula computes a nominal or starting value for *Sense Resistor Gain* from the sense resistor value (in Ω).

$$\text{Sense Resistor Gain} = 306.25/R_s$$

RSNS VALUE (m Ω)	SENSE RESISTOR GAIN
5	61250
10	30625
20	15312

CC offset

CC offset DF 0xd2–0xd3, contains the offset for the coulomb counter. It is automatically updated when the pack has met the conditions for sleep, before it enters sleep mode.

DSC offset

DSC offset DF 0xd4, contains the offset for the pack ground reference. It is automatically updated when the pack has met the conditions for sleep, before it enters sleep mode.

ADC offset

ADC offset DF 0xd5, contains the offset for the a/d converter. It is automatically updated when the pack has met the conditions for sleep, before it enters sleep mode.

Digital Filter

The desired digital filter threshold, VDF (V), is set by the value stored in *Digital Filter* DF 0x2c.

$$\text{Digital Filter} = \text{VDF} / 290 \text{ nV}$$

bq2084-V123

SLUS619A – AUGUST 2004 – REVISED JANUARY 2005

Cell and Pack Characteristics

Battery Pack Capacity and Voltage

Pack capacity in mAh units is stored in *Design Capacity*, DF 0x32–0x33. In mAh mode, the bq2084-V123 copies *Design Capacity* to `DesignCapacity()`. In mWh mode, the bq2084-V123 multiplies *Design Capacity* by *Design Voltage* DF 0x04–0x05 to calculate `DesignCapacity()` scaled to 10 mWh. *Design Voltage* is stored in mV.

The initial value for *Full Charge Capacity*, in mAh, is stored in DF 0x36–0x37. *Full Charge Capacity* is modified over the course of pack usage to reflect cell aging under the particular use conditions. The bq2084-V123 updates *Full Charge Capacity* in mAh after a capacity learning cycle.

Remaining Time and Capacity Alarms

Remaining Time Alarm in DF 0x00–0x01 and *Remaining Capacity Alarm* in DF 0x02–0x03 set the alarm thresholds used in the SMBus command codes 0x01 and 0x02, respectively. *Remaining Time Alarm* is stored in minutes and *Remaining Capacity Alarm* in units of mAh or 10 mWh, depending on the `BatteryMode()` setting.

Cycle Count Initialization

Cycle Count DF 0x0c–0x0d stores the initial value for the `CycleCount()` function. It should be programmed to 0x0000.

Cycle Count Threshold

Cycle Count Threshold 0x37–0x38 sets the number of mAh that must be removed from the battery to increment `CycleCount()`. Cycle Count threshold is a 16-bit value stored in mAh.

Charge Efficiency

The bq2084-V123 applies the efficiency factor, EFF%, to all charge added to the battery. EFF% is encoded in *Charge Efficiency* DF 0x54 according to equation 16:

$$\text{Charge Efficiency} = (\text{EFF}\% \cdot 2.56 - 1)$$

Pack Options

Pack Configuration

Pack Configuration DF 0x28 contains bit-programmable features.

b7	b6	b5	b4	b3	b2	b1	b0
DMODE	LED1	LED0	HPE	CPE	SM	CC1	CC0

DMODE

The DMODE bit determines whether the LED outputs indicate `AbsoluteStateOfCharge()` or `RelativeStateOfCharge()`.

- 0 LEDs reflect `AbsoluteStateOfCharge()`
- 1 LEDs reflect `RelativeStateOfCharge()`

LED1–LED0

The LED bits set the number of LEDs for `Remaining Capacity()` indication.

- 0–0 Configures the bq2084-V123 for five LEDs
- 0–1 Configures the bq2084-V123 for three LEDs
- 1–0 Configures the bq2084-V123 for four LEDs
- 1–1 Configures the bq2084-V123 for five LEDs

HPE

The HPE bit enables/disables PEC transmissions to the smart battery host for master mode alarm messages.

- 0 No PEC byte on alarm warning to host
- 1 PEC byte on alarm warning to host

CPE

The CPE bit enables/disables PEC transmissions to the smart battery charger for master mode messages.

- 0 No PEC byte on broadcasts to charger
- 1 PEC byte on broadcasts to charger

SM

The SM bit enables/disables master mode broadcasts by the bq2084–V123.

- 0 Broadcasts to host and charger enabled
- 1 Broadcasts to host and charger disabled

If the SM bit is set, modifications to bits in BatteryMode() do not re-enable broadcasts.

CC1–CC0

The CC bits configure the bq2084–V123 for the number of series cells in the battery pack.

- 1–1 Configures the bq2084–V123 for four series cells
- 1–0 Configures the bq2084–V123 for three series cells
- 0–1 Configures the bq2084–V123 for two series cells

Gauge Configuration

Gauge Configuration DF 0x29 contains bit–programmable features:

b7	b6	b5	b4	b3	b2	b1	b0
0	CSYNC	SC	CEDV	EDVV	OVSEL	VCOR	OTVC

CSYNC

In usual operation of the bq2084–V123, the CSYNC bit is set so that the coulomb counter is adjusted when a fast charge termination is detected. In some applications, especially those where an externally controlled charger is used, it may be desirable *not* to adjust the coulomb counter. In these cases the CSYNC bit should be cleared.

- 0 The bq2084–V123 does not alter RM at the time of a valid charge termination.
- 1 The bq2084–V123 updates RM with a programmed percentage of FCC at a valid charger termination.

SC

The SC bit enables learning cycle optimization for a Smart Charger or independent charge.

- 1 Learning cycle optimized for independent charger
- 0 Learning cycle optimized for Smart Charger

CEDV

The CEDV bit determines whether the bq2084–V123 implements automatic EDV compensation to calculate the EDV0, EDV1, and EDV2 thresholds base on rate, temperature, and capacity. If the bit is cleared, the bq2084–V123 uses the fixed values programmed in data flash for EDV0, EDV1, and EDV2. If the bit is set, the bq2084–V123 calculates EDV0, EDV1, and EDV2.

- 0 EDV compensation disabled
- 1 EDV compensation enabled

bq2084-V123

SLUS619A – AUGUST 2004 – REVISED JANUARY 2005

EDVV

The EDVV bit selects whether EDV termination is to be done with regard to Voltage () or the lowest single-cell voltage.

- 0 EDV conditions determined on the basis of the lowest single-cell voltage
- 1 EDV conditions determined on the basis of Voltage()

OVSEL

The OVSEL bit determines if Safety Over Voltage is based on Voltage () or highest cell voltages.

- 0 Safety overvoltage based on Voltage ()
- 1 Safety overvoltage based on highest cell voltage multiplied by the number of cells and then compared to the safety voltage.

VCOR

The VCOR bit enables the midrange voltage correction algorithm. When it is set, the bq2084-V123 compares the pack voltage to RM and may adjust RM according to the values programmed in VOC25, VOC50, and VOC75.

- 0 Continuous midrange corrections disabled
- 1 Continuous midrange corrections enabled

OTVC

The OTVC bit programs the bq2084-V123 to perform a midrange voltage one time after a device reset

- 0 One-time midrange correction disabled
- 1 One-time midrange correction enabled

Miscellaneous Configuration

Misc Configuration DF 0x2a (high) and 0x2b (low) contains additional bit programmable features.

Misc Configuration (high) DF 0x2a

b15	b14	b13	b12	b11	b10	b9	b8
IT	0	AFEDET	DS	OT	ECLED	1	VOD

IT

The IT bit configures the bq2084-V123 to use its internal temperature sensor. The DF constants 0xb5-0xc0 need to match the required thermistor on internal temperature sensor. See the Data Flash Settings for Internal or External Temperature Sensor Table.

- 0 bq2084-V123 requires an external thermistor.
- 1 bq2084-V123 uses its internal temperature sensor.

AFEDET

The AFEDET bit programs the bq2084-V123 to look for errors with I²C communications and the AFE and enables the detection of the AFE permanent failure if bit 3 of PF Config 0x11f is set.

- 0 Does not verify AFE communications.
- 1 Does verify AFE communications.

DS

The DS bit programs the bq2084-V123 to enter sleep mode on SMBus inactivity.

- 0 bq2084-V123 enters sleep mode when the SMBus is low for 2 s.
- 1 bq2084-V123 does not enter sleep mode.

OT

The OT bit programs the bq2084-V123 to turn off the discharge FET when the bq2084-V123 detects an over-temperature condition. Charge FET is always turned off in overtemperature conditions.

- 0 bq2084-V123 does not turn off the discharge FET on overtemperature.

- 1 bq2084-V123 turns off the discharge FET on overtemperature.

ELED

The ELED bit programs the LED activity during charging (DSG bit = 0).

- 0 The LEDs are not enabled during charging.
- 1 The LEDs are enabled during charging.

VOD

The VOD bit enables a 1-s time delay in the setting of the CVOV and CVUV bits in PackStatus.

- 0 No delay
- 1 1-s delay

Misc Configuration (low) DF 0x2b

b7	b6	b5	b4	b3	b2	b1	b0
LEDRCA	PFET1	PFET0	NR	CHGFET	0	0	0

LEDRCA

The LEDRCA bit programs the LED to blink when there is a RemainingCapacityAlarm.

- 0 The LEDs blink when there is a RemainingCapacityAlarm.
- 1 The LEDs are off there is a RemainingCapacityAlarm.

PFET1, PFET0

The PFETx bits define the precharge FET operation. See the bq29312 data sheet for more detail.

- 0,0 The bq29312 ZVCHG FET is turned on for precharge. Assumes charger has precharge function.
- 0,1 The charge FET is turned on for precharge. Assumes charger has precharge function.
- 1,0 The bq29312 OD FET is turned on for precharge. Assumes charger does not have precharge function.
- 1,1 Not defined, unpredictable operation

NR

The NR bit defines whether the bq2084-V123 is to be used with a nonremovable system battery. If set to indicate a nonremovable system battery there are additional clear conditions for a battery failure due to overcharge, overcurrent, and overload. The additional conditions besides battery removal (defined as the loss system present pin going high) are either detection of an opposite current of that that caused the failure or when AverageCurrent() is less than *Clear Fail Current* DF 0x61, 0x62 for a time defined by Fault Reset Time DF 0x130. Also, for a nonremovable battery the charge FET is left on for discharge current failures and the discharge FET is left on for charge current failures.

- 0 Removable battery, battery fail conditions cleared by battery removal only.
- 1 Nonremovable system battery.

CHGFET

The CHGFET bit programs the charge FET to remain on even after a charge terminate condition.

- 0 The charge FET is turned off after a charge termination condition.
- 1 The charge FET is turned on after a charge termination condition.

Constants and String Data

Specification Information

Specification Information DF 0x06–0x07 stores the default value for the `SpecificationInfo()` function. It is stored in data flash in the same format as the data returned by the `SpecificationInfo()`.

Manufacture Date

Manufacture Date DF 0x08–0x09 stores the default value for the `ManufactureDate()` function. It is stored in data flash in the same format as the data returned by the `ManufactureDate()`.

Serial Number

Serial Number DF 0x0a–0x0b stores the default value for the `SerialNumber()` function. It is stored in data flash in the same format as the data returned by the `SerialNumber()`.

Manufacturer Name Data

Manufacturer Name Length DF 0x0e stores the length of the desired string that is returned by the `ManufacturerName()` function. Locations DF 0x0f–0x19 store the characters for `ManufacturerName()` in ASCII code.

Device Name Data

Device Name Length DF 0x1a stores the length of the desired string that is returned by the `DeviceName()` function. Locations DF 0x1b–0x21 store the characters for `DeviceName()` in ASCII code.

Device Chemistry Data

Device Chemistry Length DF 0x22 stores the length of the desired string that is returned by the `DeviceChemistry()` function. Locations DF 0x23–0x26 store the characters for `DeviceChemistry()` in ASCII code.

Manufacturers Data Length

Manufacturers Data Length DF 0x27 stores the length of the desired number of bytes that is returned by the `ManufacturersData()` function. It should be set to 9.

Temperature Limits

The limits described below are extensions to those limits detailed in the safety and charging sections of this data sheet.

Charge Suspend Temp Low

Charge Suspend Temp Low DF 0x79 sets the lowest temperature, in degrees C/10, at which normal operation is allowed. If the temperature falls below this limit, the pack goes into a temporary failure state, the charge FET is turned off, and the MAC status is set to system present. It is cleared when the pack warms, or the pack is removed.

Charge Inhibit Temp Low

Charge Inhibit Temp Low DF 0x46 inhibits charging by setting `ChargingCurrent()` and `ChargingVoltage()` to 0 and turn off the CHG FET. It is programmed in degrees C/10 and the range of –12.8°C to 12.7°C.

Charge Inhibit Temp High

Charge Inhibit Temp High DF 0x47 – 0x48 inhibits charging by setting `ChargingCurrent()` and `ChargingVoltage()` to 0

Charge Suspend Temp High

Charge Suspend Temp High DF 0x6d–0x6e sets the highest temperature, in degrees C/10, at which charging will be allowed to continue. If this temperature is exceeded during charging, the pack goes into a temporary failure state, and the MAC status is set to system present. It is cleared when the pack cools below OverTemperature Charge Reset, or ac adapter is removed, or the pack is removed. Charging can only resume when the temperature returns to within the charge start temperature limits.

Charge Suspend Temp High Reset

Charge Suspend Temp High Reset DF 0x6f–0x70 sets the temperature, in degrees C/10, at which the pack recovers from Charge Suspend Temp High fault.

Over Temperature Discharge

Over Temperature Discharge DF 0x71–0x72 sets the highest temperature, in degrees C/10, at which discharging will be allowed. If the pack exceeds this temperature, charge and discharge FETs are turned off, and MAC status is set to system present. The pack returns to normal operation when the temperature falls below Over Temperature Discharge Reset, or if the pack is removed.

Over Temperature Discharge Reset

Over Temperature Discharge Reset DF 0x73–0x74 sets the temperature, in degrees C/10, at which the pack will recover from Over Temperature Discharge. Over temperature will also reset when the pack is removed from the system if not in the non-removable mode.

Failure Detection Thresholds

Safety OverTemperature Charge

Safety OverTemperature Charge DF 0x75–0x76 sets the temperature, in degrees C/10, above which, during charging, the pack enters permanent failure, if the XSOTC bit in Permanent Failure Configuration is set.

Safety OverTemperature Discharge

Safety OverTemperature Discharge DF 0x77–0x78 sets the temperature, in degrees C/10, above which, during discharging, the pack enters permanent failure, if the XSOTD bit in Permanent Failure Configuration is set.

Charge Detection Current

Charge Detection Current DF 0x113–0x114 sets the threshold in milliamperes for detecting charge current. This is a signed value and is positive. This threshold is used for detecting cross-conduction, and ensuring that charge termination is not improperly detected due to loss of charging current.

Discharge Detection Current

Discharge Detection Current DF 0x115–0x116 sets the threshold in milliamperes for detecting discharge current. This is a signed value and is negative. This threshold is used for detecting cross-conduction and determining that the charge FET should be turned on during discharge to reduce IR losses.

FET Fail Charge Current

FET Fail Charge Current DF 0x125–0x126 sets the threshold in milliamperes for detecting current in a charge FET which is turned off. This is a signed value and is positive.

FET Fail Discharge Current

FET Fail Discharge Current DF 0x127–0x128 sets the threshold in milliamperes for detecting current in a discharge FET which is turned off. This is a signed value and is negative.

FET Fail Time

FET Fail Time DF 0x129 sets the time in seconds that current must be detected in a FET which is turned off, in order to determine that the FET has failed.

Terminate Voltage

Terminate Voltage DF 0x67–0x68, sets the threshold below which the Terminate Discharge Alarm is set. The alarm is cleared when the voltage rises above this threshold, if the CVUV bit in Pack Status is not set.

bq2084-V123

SLUS619A – AUGUST 2004 – REVISED JANUARY 2005

Offsets and Limits

Temperature offset

Temperature offset DF 0xd6, contains a signed offset for the pack's temperature measurements, in degrees C/10. It is set at board test during pack calibration.

Board offset

Board offset DF 0xd7, contains a signed offset for the pack's coulomb counter measurements. If used, it is set at board design time.

Current Deadband

Current Deadband DF 0x7b, sets the threshold in mA below which a current measurement will not be detected.

Shutdown Voltage

Shutdown Voltage DF 0x7c–0x7d sets the pack voltage below which the pack's electronics, including the bq2084-V123, is shut down to conserve power. All FETs are turned off by the AFE.

APPLICATION INFORMATION

Figure 7 shows a typical bq2084-V123-based battery pack application. The circuit consists of the bq29312 analog front end (AFE) IC, bq29400 second level protection IC, LED, temperature measurement network, data flash connections, serial port and the sense resistor. The data flash stores basic battery pack configuration information and measurement calibration values. The data flash must be programmed properly for bq2084-V123 operation.

Figure 7. bq2084-V123 Based Battery Pack Schematic

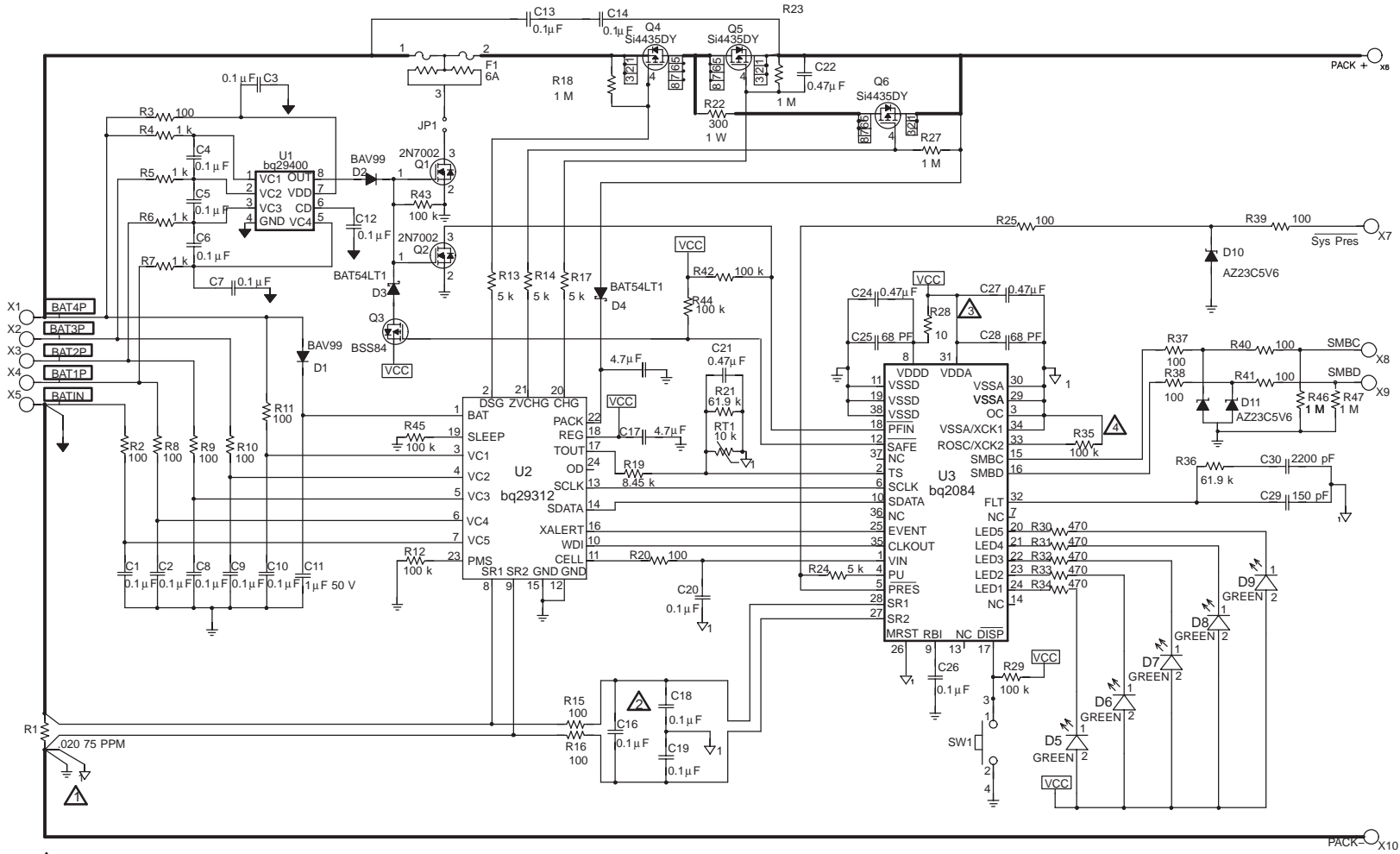

- R35 is 0.2%, 75 ppm
- Place decoupling caps C24, C25, C27, C28 VERY close to U3 between pins 8,11 and 31,30 as shown. Insure that the 68pF cap is closest to the device.
- Place these 5 parts in a symmetric pattern and route traces as a differential pair from the sense resistor to the SR1 and SR2 inputs of the bq2084. R15 and R16 should connect to the sense resistor through traces NOT the ground plane. The length of the route and the actual path (from the sense resistor to the SR1/2 inputs) should be as close to the same as possible-- same number of turns and vias. Place the entire network of resistors and capacitors as close to U3 as possible.
- Connect Analog and Digital Ground at a single point as close to the ground node of the sense resistor, R1, as possible

DBT (R-PDSO-G**)

PLASTIC SMALL-OUTLINE PACKAGE

30 PINS SHOWN

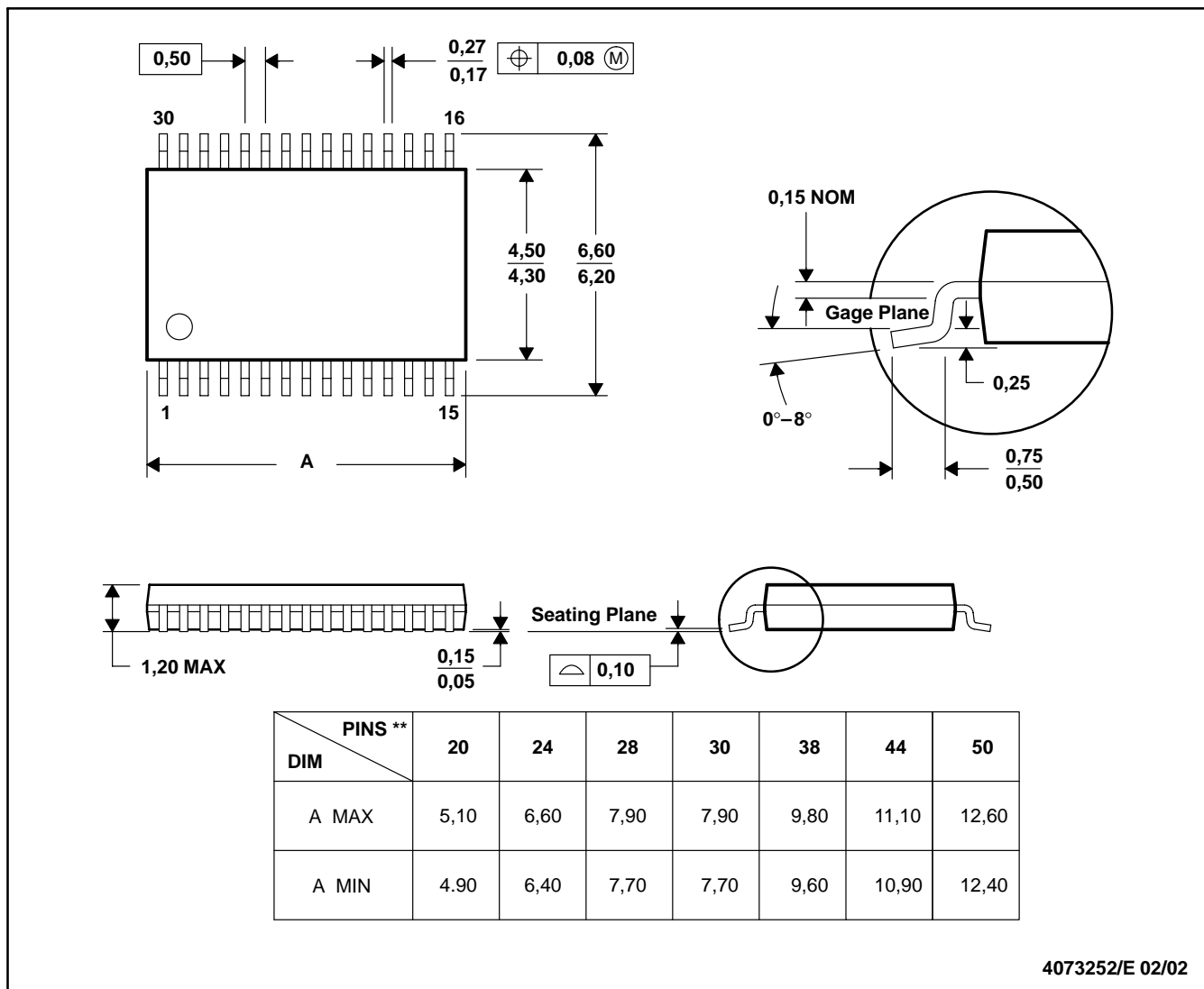

- NOTES: A. All linear dimensions are in millimeters.
 B. This drawing is subject to change without notice.
 C. Body dimensions do not include mold flash or protrusion.
 D. Falls within JEDEC MO-153

IMPORTANT NOTICE

Texas Instruments Incorporated and its subsidiaries (TI) reserve the right to make corrections, modifications, enhancements, improvements, and other changes to its products and services at any time and to discontinue any product or service without notice. Customers should obtain the latest relevant information before placing orders and should verify that such information is current and complete. All products are sold subject to TI's terms and conditions of sale supplied at the time of order acknowledgment.

TI warrants performance of its hardware products to the specifications applicable at the time of sale in accordance with TI's standard warranty. Testing and other quality control techniques are used to the extent TI deems necessary to support this warranty. Except where mandated by government requirements, testing of all parameters of each product is not necessarily performed.

TI assumes no liability for applications assistance or customer product design. Customers are responsible for their products and applications using TI components. To minimize the risks associated with customer products and applications, customers should provide adequate design and operating safeguards.

TI does not warrant or represent that any license, either express or implied, is granted under any TI patent right, copyright, mask work right, or other TI intellectual property right relating to any combination, machine, or process in which TI products or services are used. Information published by TI regarding third-party products or services does not constitute a license from TI to use such products or services or a warranty or endorsement thereof. Use of such information may require a license from a third party under the patents or other intellectual property of the third party, or a license from TI under the patents or other intellectual property of TI.

Reproduction of information in TI data books or data sheets is permissible only if reproduction is without alteration and is accompanied by all associated warranties, conditions, limitations, and notices. Reproduction of this information with alteration is an unfair and deceptive business practice. TI is not responsible or liable for such altered documentation.

Resale of TI products or services with statements different from or beyond the parameters stated by TI for that product or service voids all express and any implied warranties for the associated TI product or service and is an unfair and deceptive business practice. TI is not responsible or liable for any such statements.

Following are URLs where you can obtain information on other Texas Instruments products and application solutions:

Products		Applications	
Amplifiers	amplifier.ti.com	Audio	www.ti.com/audio
Data Converters	dataconverter.ti.com	Automotive	www.ti.com/automotive
DSP	dsp.ti.com	Broadband	www.ti.com/broadband
Interface	interface.ti.com	Digital Control	www.ti.com/digitalcontrol
Logic	logic.ti.com	Military	www.ti.com/military
Power Mgmt	power.ti.com	Optical Networking	www.ti.com/opticalnetwork
Microcontrollers	microcontroller.ti.com	Security	www.ti.com/security
		Telephony	www.ti.com/telephony
		Video & Imaging	www.ti.com/video
		Wireless	www.ti.com/wireless

Mailing Address: Texas Instruments
Post Office Box 655303 Dallas, Texas 75265

Texas Instruments

<http://www.ti.com>

This file is the datasheet for the following electronic components:

BQ2084 - <http://www.ti.com/product/bq2084?HQS=TI-null-null-dscatalog-df-pf-null-ww>

BQ2084DBT-V123 - <http://www.ti.com/product/bq2084dbt-v123?HQS=TI-null-null-dscatalog-df-pf-null-ww>

BQ2084DBTR - <http://www.ti.com/product/bq2084dbtr?HQS=TI-null-null-dscatalog-df-pf-null-ww>

BQ2084DBTR-V123 - <http://www.ti.com/product/bq2084dbtr-v123?HQS=TI-null-null-dscatalog-df-pf-null-ww>

BQ2084DBT - <http://www.ti.com/product/bq2084dbt?HQS=TI-null-null-dscatalog-df-pf-null-ww>



LittleDiode supplies new, hard to find or obsolete electronic components and semiconductors all over the world.

With over two million different components listed you are sure to find the part you need.

Feel free to visit us today at our online store:

LittleDiode.com

Looking forward to providing you with the best possible service.