

BR2500W - BR2510W

SILICON BRIDGE RECTIFIERS

PRV : 50 - 1000 Volts

Io : 25 Amperes

FEATURES :

- * High current capability
- * High surge current capability
- * High reliability
- * Low reverse current
- * Low forward voltage drop
- * High case dielectric strength

MECHANICAL DATA :

- * Case : Molded plastic with heatsink integrally mounted in the bridge encapsulation
- * Epoxy : UL94V-O rate flame retardant
- * Terminals : Plated lead solderable per MIL-STD-202, Method 208 guaranteed
- * Polarity : Polarity symbols marked on case
- * Mounting position : Bolt down on heat-sink with silicone thermal compound between bridge and mounting surface for maximum heat transfer efficiency
- * Weight : 15.95 grams

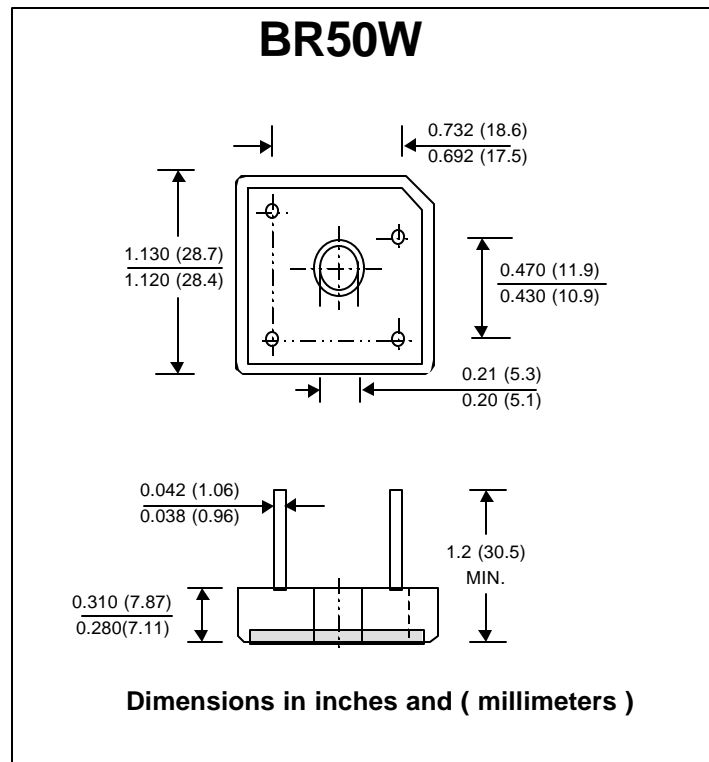

MAXIMUM RATINGS AND ELECTRICAL CHARACTERISTICS

Rating at 25 °C ambient temperature unless otherwise specified.
 Single phase, half wave, 60 Hz, resistive or inductive load.
 For capacitive load, derate current by 20%.

RATING	SYMBOL	BR	BR	BR	BR	BR	BR	BR	UNIT
		2500W	2501W	2502W	2504W	2506W	2508W	2510W	
Maximum Recurrent Peak Reverse Voltage	V _{RRM}	50	100	200	400	600	800	1000	Volts
Maximum RMS Voltage	V _{RMS}	35	70	140	280	420	560	700	Volts
Maximum DC Blocking Voltage	V _{DC}	50	100	200	400	600	800	1000	Volts
Maximum Average Forward Current T _c = 55°C	I _{F(AV)}	25							Amp.
Peak Forward Surge Current Single half sine wave Superimposed on rated load (JEDEC Method)	I _{FSM}	300							Amp.
Current Squared Time at t < 8.3 ms.	I ² t	375							A ² S
Maximum Forward Voltage per Diode at 12.5 Amp.	V _F	1.1							Volts
Maximum DC Reverse Current at Rated DC Blocking Voltage	I _R	10							µA
		1.0							mA
Typical Thermal Resistance at Junction to Case (Note 1)	R _{θJC}	2							°C/W
Typical Thermal Resistance at Junction to Ambient	R _{θJA}	22							°C/W
Operating Junction Temperature Range	T _J	- 40 to + 150							°C
Storage Temperature Range	T _{STG}	- 40 to + 150							°C

Notes : 1) Thermal resistance from Junction to Case with units mounted on a 5" x 4" x 3" (12.7 x 10.2 x 7.3 cm) Al.-wing plate.

UPDATE : APRIL 21, 1998

RATING AND CHARACTERISTIC CURVES (BR2500W - BR2510W)

FIG.1 - DERATING CURVE FOR OUTPUT RECTIFIED CURRENT

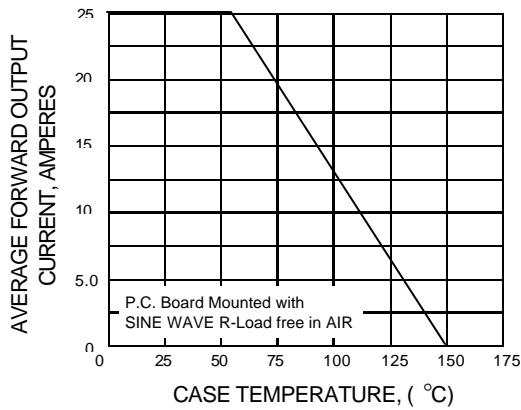

FIG.2 - MAXIMUM NON-REPETITIVE PEAK FORWARD SURGE CURRENT

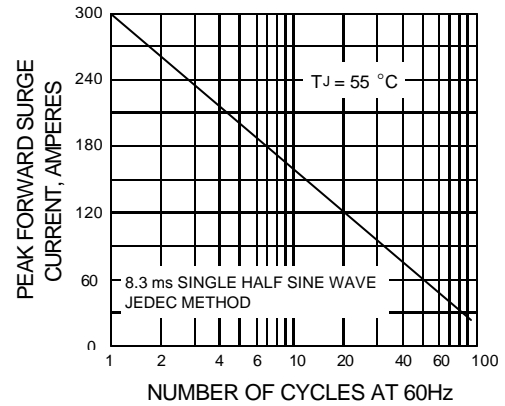

FIG.3 - TYPICAL FORWARD CHARACTERISTICS

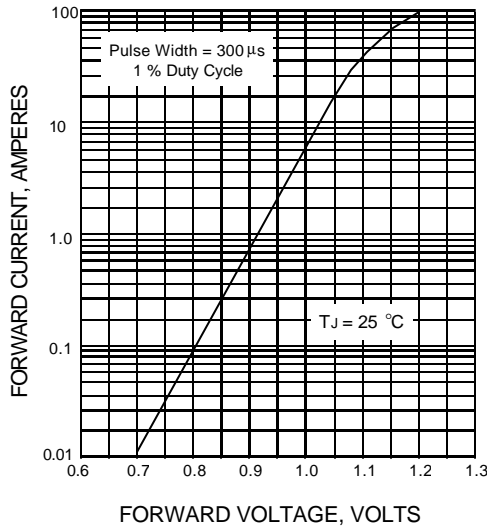
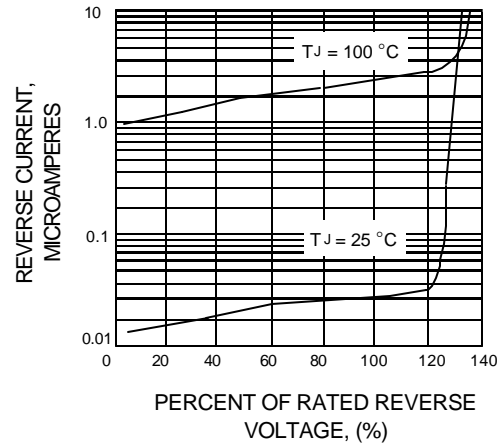

FIG.4 - TYPICAL REVERSE CHARACTERISTICS





LittleDiode supplies new, hard to find or obsolete electronic components and semiconductors all over the world.

With over two million different components listed you are sure to find the part you need.

Feel free to visit us today at our online store:

LittleDiode.com

Looking forward to providing you with the best possible service.