

DATA SHEET

BSD22 MOSFET N-channel depletion switching transistor

Product specification
File under Discrete Semiconductors, SC07

December 1997

MOSFET N-channel depletion switching transistor

BSD22

DESCRIPTION

Symmetrical insulated-gate silicon MOS field-effect transistor of the n-channel depletion mode type. The transistor is sealed in a SOT143 envelope and features a low ON-resistance and low capacitances. The transistor is protected against excessive input voltages by integrated back-to-back diodes between gate and substrate.

Applications:

- analog and/or digital switch
- switch driver
- convertor
- chopper

PINNING

- 1 = substrate (b)
- 2 = source
- 3 = drain
- 4 = gate

Note

1. Drain and source are interchangeable

Marking code: M32

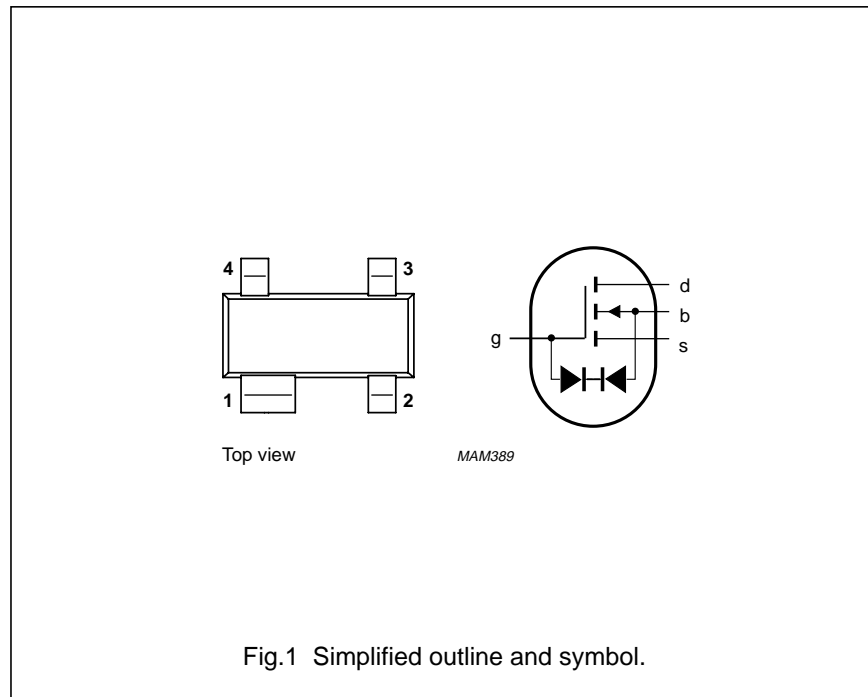

QUICK REFERENCE DATA

Drain-source voltage	V_{DS}	max.	20	V
Gate-source voltage	V_{GS}	max.	+ 15	V
			- 40	V
Drain current (DC)	I_D	max.	50	mA
Total power dissipation up to $T_{amb} = 25\text{ °C}$	P_{tot}	max.	230	mW
Junction temperature	T_j	max.	125	°C
Drain-source ON-resistance				
$V_{GS} = 10\text{ V}; V_{SB} = 0; I_D = 1\text{ mA}$	R_{DSon}	max.	30	Ω
Feed-back capacitance				
$V_{GS} = V_{BS} = -5\text{ V}; V_{DS} = 10\text{ V}; f = 1\text{ MHz}$	C_{rss}	typ.	0.6	pF

MOSFET N-channel depletion switching transistor

BSD22

RATINGS

Limiting values in accordance with the Absolute Maximum System (IEC 134)

Drain-source voltage	V_{DS}	max.	20	V
Source-drain voltage	V_{SD}	max.	20	V
Drain-substrate voltage	V_{DB}	max.	25	V
Source-substrate voltage	V_{SB}	max.	25	V
Gate-substrate voltage	V_{GB}	max.	± 15	V
Gate-source voltage	V_{GS}	max.	+ 15 – 40	V
Drain current (DC)	I_D	max.	50	mA
Total power dissipation up to $T_{amb} = 25\text{ }^\circ\text{C}^{(1)}$	P_{tot}	max.	230	mW
Storage temperature range	T_{stg}		–65 to + 150	$^\circ\text{C}$
Junction temperature	T_j	max.	125	$^\circ\text{C}$

THERMAL RESISTANCE

From junction to ambient in free air ⁽¹⁾	$R_{th\ j-a}$	=	430	K/W
---	---------------	---	-----	-----

Note

1. Device mounted on a ceramic substrate of 8 mm × 10 mm × 0.7 mm.

CHARACTERISTICS $T_{amb} = 25\text{ }^\circ\text{C}$ unless otherwise specified

Drain-source breakdown voltage $V_{GS} = V_{BS} = -5\text{ V}$; $I_S = 10\text{ nA}$	$V_{(BR)DSX}$	min.	20	V
Source-drain breakdown voltage $V_{GD} = V_{BD} = -5\text{ V}$; $I_D = 10\text{ nA}$	$V_{(BR)SDX}$	min.	20	V
Drain-substrate breakdown voltage $V_{GB} = 0$; $I_D = 10\text{ nA}$; open source	$V_{(BR)DBO}$	min.	25	V
Source-substrate breakdown voltage $V_{GB} = 0$; $I_S = 10\text{ nA}$; open drain	$V_{(BR)SBO}$	min.	25	V
Drain-source leakage current $V_{GS} = V_{BS} = -5\text{ V}$; $V_{DS} = 10\text{ V}$	I_{DSoff}	typ.	1.0	nA
Source-drain leakage current $V_{GD} = V_{BD} = 5\text{ V}$; $V_{SD} = 10\text{ V}$	I_{SDoff}	typ.	1.0	nA
Gate-substrate leakage current $V_{DB} = V_{SB} = 0$; $V_{GB} = \pm 15\text{ V}$	I_{GBS}	max.	10	nA
Forward transconductance at $f = 1\text{ kHz}$ $V_{DS} = 10\text{ V}$; $V_{SB} = 0$; $I_D = 20\text{ mA}$	g_{fs}	min. typ.	10 15	mS mS
Gate-source cut-off voltage $V_{DS} = 10\text{ V}$; $V_{SB} = 0$; $I_D = 10\text{ }\mu\text{A}$	$-V_{(P)GS}$	max.	2.0	V

MOSFET N-channel depletion switching transistor

BSD22

Drain-source ON-resistance

$I_D = 1 \text{ mA}; V_{SB} = 0;$
 $V_{GS} = 5 \text{ V}$

R_{DSon}	typ.	25	Ω
	max.	50	Ω

$V_{GS} = 10 \text{ V}$

R_{DSon}	typ.	15	Ω
	max.	30	Ω

Capacitances at $f = 1 \text{ MHz}$

$V_{GS} = V_{BS} = -5 \text{ V}; V_{DS} = 10 \text{ V}$

Feed-back capacitance

C_{rss}	typ.	0.6	pF
-----------	------	-----	----

Input capacitance

C_{iss}	typ.	1.5	pF
-----------	------	-----	----

Output capacitance

C_{oss}	typ.	1.0	pF
-----------	------	-----	----

Switching times (see Fig.3)

$V_{DD} = 10 \text{ V}; V_i = -5 \text{ V to } +5 \text{ V}$

t_{on}	typ.	1.0	ns
t_{off}	typ.	5.0	ns

$$C_{iss} = C_{gs} + C_{gd} + C_{gb}$$

$$C_{oss} = C_{gd} + C_{bd}$$

$$C_{rss} = C_{gd}$$

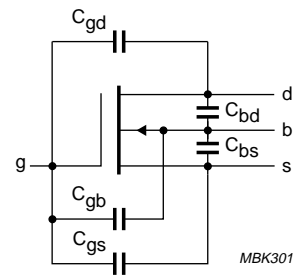

Fig.2 Capacitances model.

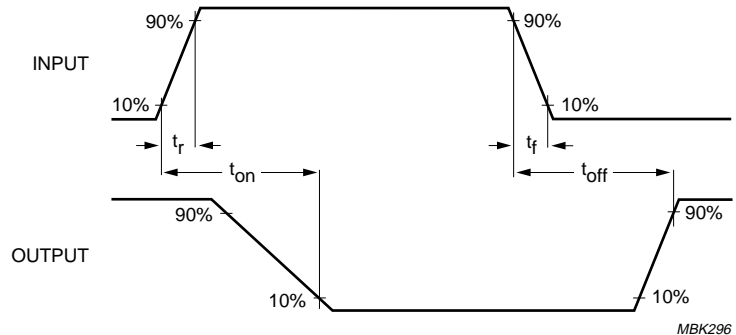
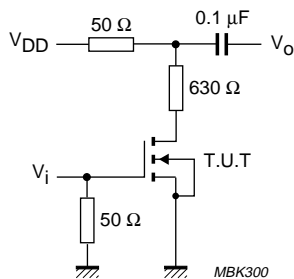

Fig.3 Switching times and input and output waveforms; $R_i = 50 \Omega; t_r < 0.5 \text{ ns}; t_f < 1.0 \text{ ns}; t_p = 20 \text{ ns}; \delta < 0.01.$

MOSFET N-channel depletion switching transistor

BSD22

PACKAGE OUTLINE

Plastic surface mounted package; 4 leads

SOT143B

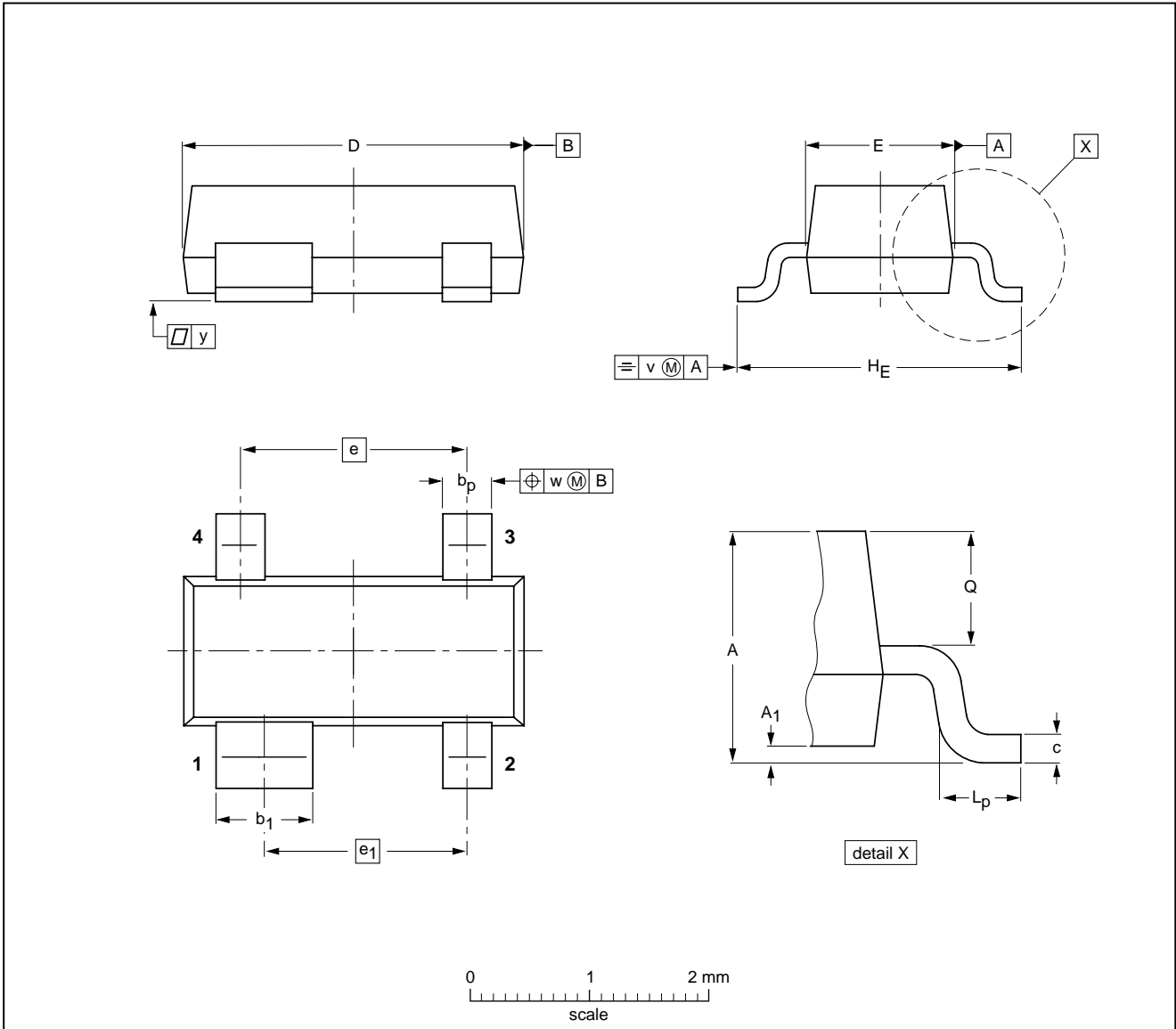

DIMENSIONS (mm are the original dimensions)

UNIT	A	A ₁ max	b _p	b ₁	c	D	E	e	e ₁	H _E	L _p	Q	v	w	y
mm	1.1 0.9	0.1	0.48 0.38	0.88 0.78	0.15 0.09	3.0 2.8	1.4 1.2	1.9	1.7	2.5 2.1	0.45 0.15	0.55 0.45	0.2	0.1	0.1

OUTLINE VERSION	REFERENCES				EUROPEAN PROJECTION	ISSUE DATE
	IEC	JEDEC	EIAJ			
SOT143B						97-02-28

MOSFET N-channel depletion switching transistor

BSD22

DEFINITIONS

Data sheet status	
Objective specification	This data sheet contains target or goal specifications for product development.
Preliminary specification	This data sheet contains preliminary data; supplementary data may be published later.
Product specification	This data sheet contains final product specifications.
Short-form specification	The data in this specification is extracted from a full data sheet with the same type number and title. For detailed information see the relevant data sheet or data handbook.
Limiting values	
Limiting values given are in accordance with the Absolute Maximum Rating System (IEC 134). Stress above one or more of the limiting values may cause permanent damage to the device. These are stress ratings only and operation of the device at these or at any other conditions above those given in the Characteristics sections of the specification is not implied. Exposure to limiting values for extended periods may affect device reliability.	
Application information	
Where application information is given, it is advisory and does not form part of the specification.	

LIFE SUPPORT APPLICATIONS

These products are not designed for use in life support appliances, devices, or systems where malfunction of these products can reasonably be expected to result in personal injury. Philips customers using or selling these products for use in such applications do so at their own risk and agree to fully indemnify Philips for any damages resulting from such improper use or sale.



LittleDiode supplies new, hard to find or obsolete electronic components and semiconductors all over the world.

With over two million different components listed you are sure to find the part you need.

Feel free to visit us today at our online store:

LittleDiode.com

Looking forward to providing you with the best possible service.