

## **Addendum for PCN-Datasheet 2004-018-A: BTS 5240 G**

This Addendum and PCN-Datasheet refers to the PCN 2004-018-A:  
 “Minor datasheet adaption for BTS 5240 L, BTS 5240 G, BTS 5440 G “.  
 The PCN-datasheet attached will be valid starting from August 2004.

There are the following changes in the datasheet (on page 7):

Old:

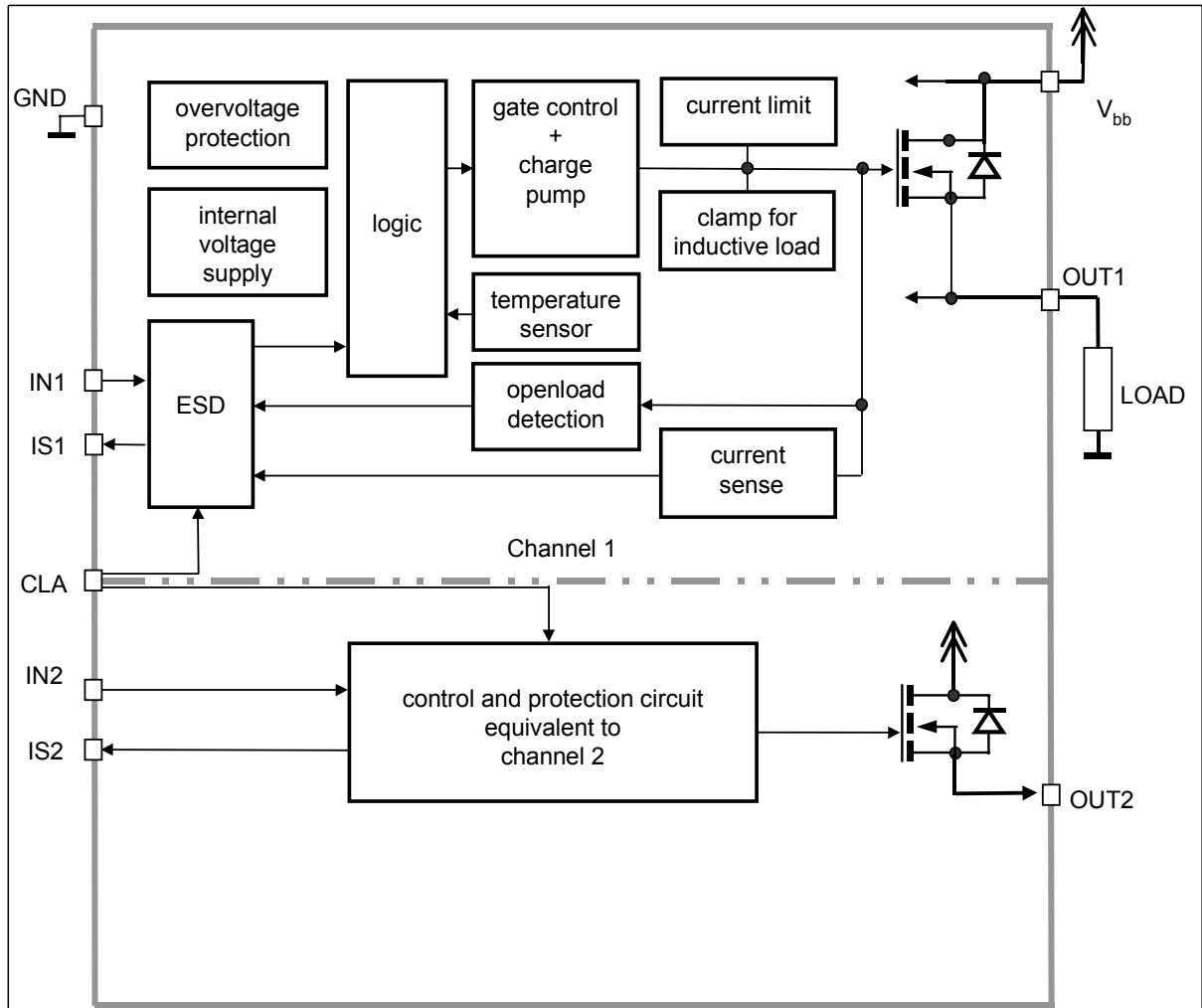
	Symbol	min	typ	max	Unit
Current limit adjustment threshold voltage	$V_{CLA(T-)}$	2.6	-	-	V
		-	-	3.6	

New:

	Symbol	min	typ	max	Unit
Current limit adjustment threshold voltage	$V_{CLA(T-)}$	2.0	-	-	V
		-	-	4.0	



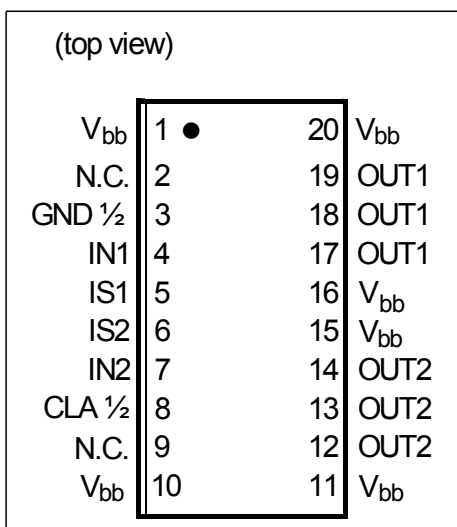
Functional diagram



**Pin definition and function**

Pin	Symbol	Function
4	IN1	<b>Input 1,2</b> activates channel1,2 in case of logic high signal
7	IN2	
5	IS1	<b>Diagnostic feedback 1 &amp; 2</b> of channel 1,2 On state: advanced current sense with defined signal in case of overload or short circuit Off state: High on failure
6	IS2	
3	GND 1/2	<b>Ground</b> of chip
1,10, 11,15, 16,20	V <sub>bb</sub>	<b>Positive power supply voltage.</b> Design the wiring for the simultaneous max. short circuit currents from channel 1 to 2 and also for low thermal resistance
8	CLA	<b>Current limit adjust</b> , the current limit for both channels can be chosen as high ( potential < 2,6V ) or low ( potential > 3,6V ).
17,18,19	OUT1	<b>Output 1,2</b> protected high-side power output of channel 1,2. Design the wiring for the max. short circuit current.
12,13,14	OUT2	
2,9	N.C.	Not connected

**Pin configuration**



**Maximum Ratings at  $T_j=25^\circ\text{C}$ , unless otherwise specified**

Parameter	Symbol	Value	Unit
Supply voltage (overvoltage protection see page 6)	$V_{bb}$	28 <sup>1)</sup>	V
Supply voltage for full short circuit protection; $T_j = -40\dots150^\circ\text{C}$	$V_{bb(SC)}$	28 <sup>2)</sup>	
Maximum voltage across DMOS	$V_{ON}$	52	
Load dump protection <sup>3)</sup> $V_{LoadDump}^{4)} = V_A + V_S$ ; $V_A = 13,5\text{ V}$ In = low or high; $t_d = 400\text{ ms}$ ; $R_I^{4)} = 2\ \Omega$ $R_L = 2.25\ \Omega$ $R_L = 6.8\ \Omega$	$V_{Loaddump}$	40 53	
Load current (Short - circuit current, see page 7)	$I_L$	$I_{L(lim)}^{5)}$	A
Operating temperature range	$T_j$	$-40\dots+150$	$^\circ\text{C}$
Storage temperature range	$T_{stg}$	$-55\dots+150$	
Dynamical temperature rise at switching	$dT$	60	K
Power dissipation <sup>6)</sup> (DC), one channel active $T_A = 85\ ^\circ\text{C}$	$P_{tot}$	1,4	W
Maximal switchable inductance, single pulse $V_{bb}=12\text{V}$ , $T_{jstart}=150^\circ\text{C}$ ; (see diagrams on page 12) $I_L = 6\text{ A}$ , $E_{AS} = 0.319\text{ J}$ , $R_L = 0\ \Omega$ , one channel: $I_L = 12\text{ A}$ , $E_{AS} = 0.679\text{ J}$ , $R_L = 0\ \Omega$ , two parallel channels:	$Z_{L(s)}$	9.8 5.2	mH
<b>Electrostatic discharge voltage</b> (Human Body Model) according to ANSI EOS/ESD - S5.1 - 1993 , ESD STM5.1 - 1998	IN: $V_{ESD}$ IS: OUT:	1.0 2.0 4.0	kV
Continuous input voltage	$V_{IN}$	$-10\dots16$	V
Voltage at current limit adjustment pin	$V_{CLA}$	$-10\dots16$	
Current limit adjustment current	$I_{CLA}$	$\pm 5.0$	mA
Current through input pin (DC)	$I_{IN}$	$\pm 5.0$	
Current through sense (DC) (see page 11)	$I_{IS}$	$-5\dots10$	

<sup>1</sup>18...28 V for 100 hours

<sup>2</sup>only single pulse,  $R_L = 200\text{ m}\Omega$  ;  $L = 8\ \mu\text{H}$  ; R and L are describing the complete circuit impedance including line, contact and generator impedances.

<sup>3</sup>Supply voltage higher than  $V_{bb(AZ)}$  require an external current limit for the GND (150 $\Omega$  resistor) and sense pin.

<sup>4</sup> $R_I$  = internal resistance of the load dump test pulse generator.

<sup>5</sup>Current limit is a protection function. Operation in current limitation is considered as "outside" normal operating range. Protection functions are not designed for continuous repetitive operation.

<sup>6</sup>Device on 50mm\*50mm\*1.5mm epoxy PCB FR4 with 6 cm<sup>2</sup> (one layer, 70 $\mu\text{m}$  thick) copper area for  $V_{bb}$  connection. PCB is vertical without blown air.

**Electrical Characteristics**

Parameter and Conditions, each of the two channels at $T_j = -40...+150\text{ °C}$ , $V_{bb} = 9...16\text{ V}$ , unless otherwise specified	Symbol	Values			Unit
		min.	typ.	max.	

**Thermal Resistance**

junction - soldering point	each channel:	$R_{thJS}$	-	18	-	K/W
junction - ambient <sup>1)</sup>	one channel active:	$R_{thJA}$	-	44	-	K/W
	all channels active:		-	42	-	

**Load Switching Capabilities and Characteristics**

On-state resistance ( $V_{bb}$ to OUT), (see page 13) $T_j = 25\text{ °C}$ , $I_L = 5\text{ A}$ , $T_j = 150\text{ °C}$ , $T_j = 25\text{ °C}$ ,	each channel: each channel: two parallel channels:	$R_{ON}$	-	21 42 11	25 50 13	mΩ
Nominal load current <sup>1)</sup> $T_a = 85\text{ °C}$ , $T_j \leq 150\text{ °C}$ ,	one channel active: two channels active, per channel:	$I_{L(nom)}$	5.4 3.9	5.9 4.2	- -	A
Output voltage drop limitation at small load currents $I_L = 0.5\text{ A}$		$V_{ON(NL)}$	-	40	-	mV
Output current while GND disconnected <sup>2)</sup> ( see diagram page 12 ) $V_{IN} = 0\text{ V}$		$I_{L(GNDhigh)}$	-	-	2	mA

<sup>1</sup>Device on 50mm\*50mm\*1.5mm epoxy PCB FR4 with 6 cm2 (one layer, 70µm thick) copper area for  $V_{bb}$  connection. PCB is vertical without blown air.

<sup>2</sup>not subject to production test, specified by design

**Electrical Characteristics**

Parameter and Conditions, each of the two channels at $T_j = -40...+150\text{ }^\circ\text{C}$ , $V_{bb} = 9...16\text{ V}$ , unless otherwise specified	Symbol	Values			Unit
		min.	typ.	max.	

**Load Switching Capabilities and Characteristics**

Turn-on time <sup>1)</sup> to 90% $V_{OUT}$ $R_L = 12\ \Omega$ , $V_{bb} = 12\text{ V}$	$t_{on}$	-	90	200	$\mu\text{s}$
Turn-off time <sup>1)</sup> to 10% $V_{OUT}$ $R_L = 12\ \Omega$ , $V_{bb} = 12\text{ V}$	$t_{off}$	-	100	220	
Slew rate on <sup>1)</sup> 10 to 30% $V_{OUT}$ , $R_L = 12\ \Omega$ , $V_{bb} = 12\text{ V}$	$dV/dt_{on}$	0.1	0.25	0.45	$\text{V}/\mu\text{s}$
Slew rate off <sup>1)</sup> 70 to 40% $V_{OUT}$ , $R_L = 12\ \Omega$ , $V_{bb} = 12\text{ V}$	$-dV/dt_{off}$	0.09	0.25	0.4	

**Operating Parameters**

Operating voltage <sup>2)</sup>	$V_{bb(on)}$	4.5	-	28	V
Overvoltage protection <sup>3)</sup> $I_{bb} = 40\text{ mA}$	$V_{bb(AZ)}$	41	47	52	
Standby current <sup>4)</sup> (see diagram on page 13) $T_j = -40...+25\text{ }^\circ\text{C}$ , $V_{IN} = 0\text{ V}$ $T_j = 150\text{ }^\circ\text{C}$	$I_{bb(off)}$	-	5	7.5	$\mu\text{A}$
		-	-	20	

<sup>1</sup>See timing diagram on page 14.

<sup>2</sup>18V...28V for 100 hours

<sup>3</sup>Supply voltages higher than  $V_{bb(AZ)}$  require an external current limit for the status pin and GND pin (e.g.  $150\ \Omega$ ).  
See also  $V_{Out(CL)}$  in table of protection functions and circuit diagram on page 11.

<sup>4</sup>Measured with load; for the whole device; all channels off.

**Electrical Characteristics**

Parameter and Conditions, each of the two channels at $T_j = -40...+150\text{ }^\circ\text{C}$ , $V_{bb} = 9...16\text{ V}$ , unless otherwise specified	Symbol	Values			Unit
		min.	typ.	max.	
<b>Operating Parameters</b>					
Off-State output current (included in $I_{bb(off)}$ ) $V_{IN} = 0\text{ V}$ , each channel	$I_{L(off)}$	-	1.5	8	$\mu\text{A}$
Operating current <sup>1)</sup> $V_{IN} = 5\text{ V}$ , per active channel	$I_{GND}$	-	1.6	4	mA
<b>Protection Functions<sup>2)</sup></b>					
Current limit, ( see timing diagrams, page 15 ) Low level; if potential at CLA = high High level; if potential at CLA = low	$I_{L(LIM)}$	7 40	11 50	14 60	A
Current limit adjustment threshold voltage	$V_{CLA(T-)}$ $V_{CLA(T+)}$	2.0 -	- -	- 4.0	V
Repetitive short circuit current limit $T_j = T_{jt}$ (see timing diagrams on page 15) High level Low level	$I_{L(SCr)}$	- -	40 40 7 7	- -	A
Initial short circuit shutdown time $T_{j,start} = 25^\circ\text{C}$ ; $V_{bb} = 13,5\text{ V}$	low level: high level: $t_{off(SC)}$	- -	3.5 0.75	- -	ms
Output clamp (inductive load switch off) <sup>4)</sup> $I_L = 40\text{ mA}$	$V_{OUT(CL)}$	-	-15	-	V
Thermal overload trip temperature	$T_{jt}$	150	170	-	$^\circ\text{C}$
Thermal hysteresis	$\Delta T_{jt}$	-	10	-	K

<sup>1</sup>Add  $I_{IS}$ , if  $I_{IS} > 0$

<sup>2</sup>Integrated protection functions are designed to prevent IC destruction under fault conditions described in the data sheet. Fault conditions are considered as "outside" normal operating range. Protection functions are not designed for continuous repetitive operation.

<sup>3</sup>At the beginning of the short circuit the double current is possible for a short time.

<sup>4</sup>If channels are connected in parallel, output clamp is usually accomplished by the channel with the lowest  $V_{OUT(CL)}$ .

**Electrical Characteristics**

Parameter and Conditions, each of the two channels at $T_j = -40...+150\text{ °C}$ , $V_{bb} = 9...16\text{ V}$ , unless otherwise specified	Symbol	Values			Unit
		min.	typ.	max.	

**Diagnostic Characteristics**

Open load detection voltage	$V_{OUT(OL)}$	2	3.2	4.4	V
Internal output pull down <sup>1)</sup> $V_{OUT} = 13.5\text{ V}$	$R_{OUT(PD)}$	11	23	35	k $\Omega$
Current sense ratio, static on-condition $k_{ILIS} = I_L : I_{IS}$ $I_L = 0.5\text{ A}$ $I_L = 3\text{ A}$ $I_L = 6\text{ A}$	$k_{ILIS}$	4640 4900 4900	5800 5400 5350	6960 5900 5800	
Sense signal in case of fault-conditions <sup>2)</sup> in off-state	$V_{fault}$	5	6.2	7.5	V
Current saturation of sense fault signal	$I_{fault}$	4	-	-	mA
Sense signal delay after thermal shutdown <sup>3)</sup>	$t_{delay(fault)}$	-	-	1.2	ms
Current sense output voltage limitation $I_{IS} = 0$ , $I_L = 5\text{ A}$	$V_{IS(lim)}$	5.4	6.5	7.3	V
Current sense leakage/offset current $V_{IN} = 5\text{ V}$ , $I_L = 0$ , $V_{IS} = 0$	$I_{IS(LH)}$	-	-	5	$\mu\text{A}$
Current sense settling time to $I_{IS}$ static $\pm 10\%$ after positive input slope <sup>4)</sup> , $I_L = 0$ to 5A	$t_{son(IS)}$	-	-	400	$\mu\text{s}$
Current sense settling time to $I_{IS}$ static $\pm 10\%$ after change of load current <sup>4)</sup> , $I_L = 2.5$ to 5A	$t_{slc(IS)}$	-	-	300	

<sup>1</sup>In case of floating output, the status doesn't show open load.

<sup>2</sup>Fault condition means output voltage exceeds open load detection voltage  $V_{OUT(OL)}$

<sup>3</sup>In the case of thermal shutdown the  $V_{fault}$  signal remains for  $t_{delay(fault)}$  longer than the restart of the switch ( see diagram on page 16 ).

<sup>4</sup>not subject to production test, specified by design

**Electrical Characteristics**

Parameter	Symbol	Values			Unit
		min.	typ.	max.	
at $T_j = -40...+150\text{ }^\circ\text{C}$ , $V_{bb} = 9...16\text{ V}$ , unless otherwise specified					

**Diagnostic Characteristics**

Status invalid after negative input slope	$t_{d(SToff)}$	-	-	1.2	ms
Status invalid after positive input slope with open load	$t_{d(STOL)}$	-	-	20	$\mu\text{s}$

**Input Feedback<sup>1)</sup>**

Input resistance (see circuit page 11)	$R_I$	2.0	3.5	5.5	$\text{k}\Omega$
Input turn-on threshold voltage	$V_{IN(T+)}$	-	-	2.4	V
Input turn-off threshold voltage	$V_{IN(T-)}$	1.0	-	-	
Input threshold hysteresis	$\Delta V_{IN(T)}$	-	0.5	-	
Off state input current $V_{IN} = 0.4\text{ V}$	$I_{IN(off)}$	3	-	40	$\mu\text{A}$
On state input current $V_{IN} = 5\text{ V}$	$I_{IN(on)}$	20	50	90	

**Reverse Battery<sup>2)</sup>**

Reverse battery	$-V_{bb}$	-	-	27	V
Drain-source diode voltage ( $V_{OUT} > V_{bb}$ ) $T_j = 150\text{ }^\circ\text{C}$ , $I_{bb} = -10\text{ mA}$	$-V_{ON}$	-	330	-	mV

<sup>1</sup>If ground resistors  $R_{GND}$  are used, add the voltage drop across these resistor.

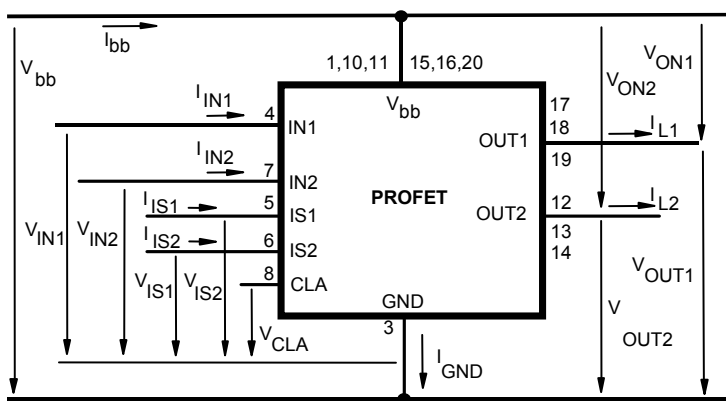
<sup>2</sup>Requires a  $150\Omega$  resistor in GND connection. The reverse load current through the intrinsic drain-source diode has to be limited by the connected load. Power dissipation is higher compared to normal operating conditions due to the voltage drop across the drain-source diode. The temperature protection is not active during reverse current operation! Input and status currents have to be limited. (see max. ratings page 4)

**Truth Table - for each of the two channels**

	Input level	Output level	Diagnostic output
Normal Operation	L	L	Z <sup>1)</sup>
	H	V <sub>bb</sub>	I <sub>IS</sub> = I <sub>L</sub> / kilis
Current Limitation <sup>2)</sup>	H	V <sub>bb</sub>	V <sub>fault</sub>
Short circuit to GND	L	L	Z <sup>1)</sup>
	H	L	V <sub>fault</sub>
Overtemperature	L	L	Z <sup>1)</sup>
	H	L	V <sub>fault</sub>
Short circuit to V <sub>bb</sub>	L	V <sub>bb</sub>	V <sub>fault</sub>
	H	V <sub>bb</sub>	< I <sub>IS</sub> = I <sub>L</sub> / kilis <sup>3)</sup>
Open load	L	> V <sub>out(OL)</sub>	V <sub>fault</sub>
	H	V <sub>bb</sub>	Z <sup>1)</sup>

L = " Low" Level    Z = high impedance, potential depends on external circuit  
H = "High" Level    V<sub>fault</sub> = 5V typ., constant voltage independent of external sense resistor.  
Parallel switching of channels is possible by connecting the inputs and outputs parallel.  
The current sense outputs have to be connected with a single sense resistor.

**Terms**



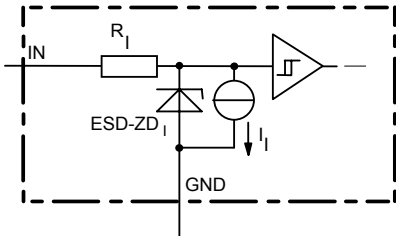
Leadframe ( V<sub>bb</sub> ) is connected to pin 1,10,11,15,16,20

<sup>1</sup>L-potential by using a sense resistor

<sup>2</sup>Current limitation is only possible while the device is switched on.

<sup>3</sup>Low ohmic short to V<sub>bb</sub> may reduce the output current I<sub>L</sub> and therefore also the sense current I<sub>IS</sub>.

**Input circuit ( ESD protection ), IN1 or IN2**

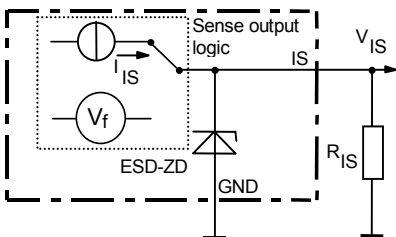


The use of ESD zener diodes as voltage clamp at DC conditions is not recommended.

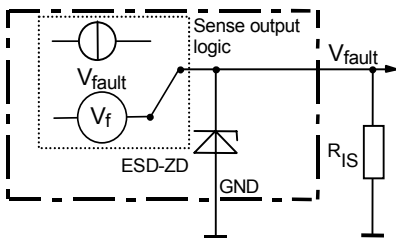
**Sense-Status output, IS1 or IS2**

ON-State: Normal operation:  $I_S = I_L / k$  ILIS

$V_{IS} = I_S * R_{IS}$ ;  $R_{IS} = 1k\Omega$  nominal  
 $R_{IS} > 500\Omega$

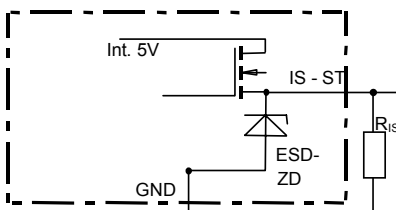


ESD zener diode:  $V_{ESD} = 6,1$  V typ., max. 14 mA ;  
 ON-State: Fault condition so as thermal shut down or current limitation



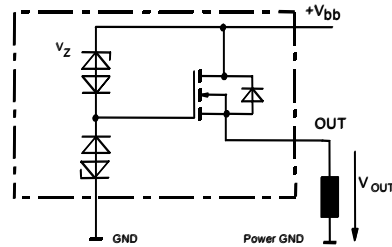
$V_{fault} = 6$  V typ ;  $V_{fault} < V_{ESD}$  under all conditions

OFF-State diagnostic condition:  
 Open Load, if  $V_{OUT} > 3$  V typ.; IN low



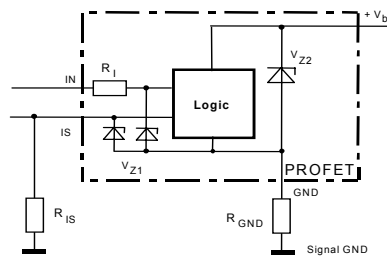
ESD-Zener diode: 6,1V typ., max. 5mA;  $R_{ST(ON)} < 375\Omega$  at 1,6mA.. The use of ESD zener diodes as voltage clamp at DC conditions is not recommended.

**Inductive and overvoltage output clamp, OUT1 or OUT2**



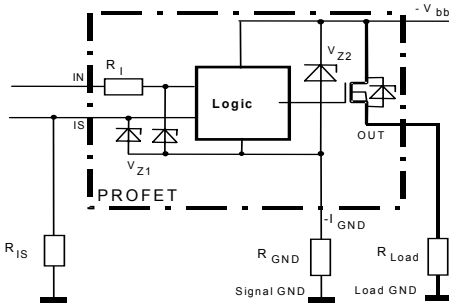
$V_{OUT}$  clamped to  $V_{OUT(CL)} = -15$  V typ.

**Overvolt. Protection of logic part OUT1 or OUT2**



$V_{Z1} = 6,1$ V typ.,  $V_{Z2} = 47$ V typ.,  $R_{GND} = 150\Omega$  ,  
 $R_{IS} = 1k\Omega$  ,  $R_1 = 3,5k\Omega$  typ.

**Reverse battery protection**  
OUT1 or OUT2

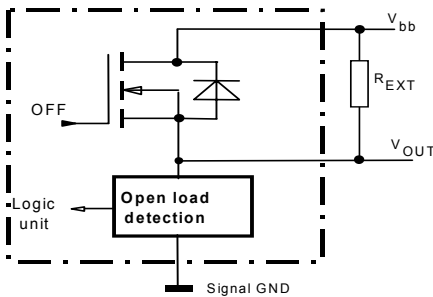


$V_{Z1} = 6,1V$  typ.,  $V_{Z2} = 47V$  typ.,  $R_{GND} = 150\Omega$   
 $R_{IS} = 1k\Omega$ ,  $R_1 = 3,5k\Omega$  typ.

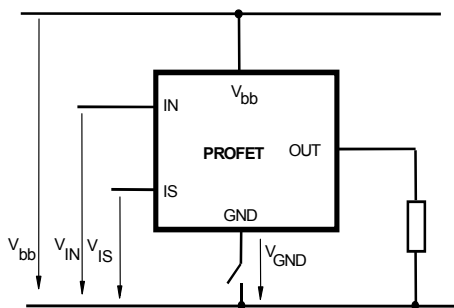
In case of reverse battery the load current has to be limited by the load. Protection functions are not active.

**Open load detection, OUT1 or 2**

Off-state diagnostic condition:  
 Open load, if  $V_{OUT} > 3 V$  typ.;  $IN = low$

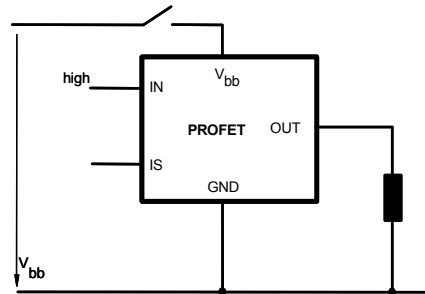


**GND disconnect**



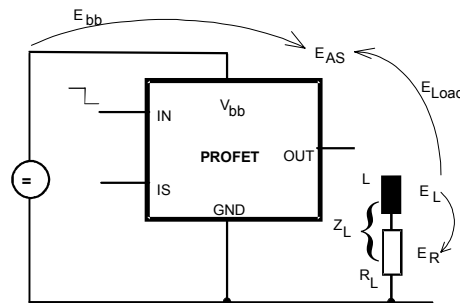
Any kind of load.

**Vbb disconnect with energized inductive load**



For inductive load currents up to the limits defined by  $Z_L$  each switch is protected against loss of  $V_{bb}$ . (max. ratings and diagram on page 12)  
 Consider at your PCB layout that in the case of  $V_{bb}$  disconnection with energized inductive load all the load current flows through the GND connection.

**Inductive load switch-off energy dissipation**



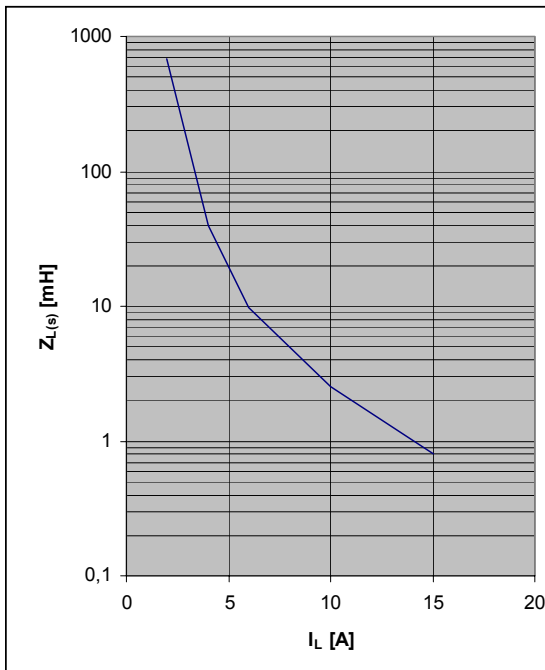
Energy stored in load inductance:  $E_L = \frac{1}{2} * L * I_L^2$

While demagnetizing load inductance, the energy dissipated in PROFET is  $E_{AS} = E_{bb} + E_L - E_R = V_{ON(CL)} * i_L(t) dt$ , with an approximate solution for  $R_L > 0\Omega$ :

$$E_{AS} = \frac{I_L * L}{2 * R_L} * (V_{bb} + |V_{OUT(CL)}|) * \ln\left(1 + \frac{I_L * R_L}{|V_{OUT(CL)}|}\right)$$

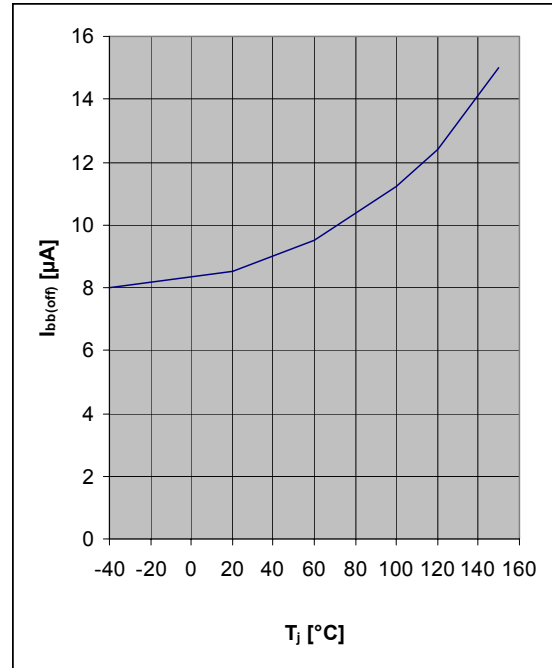
**Maximum allowable load inductance  
for a single switch off (one channel)**

$L = f(I_L)$ ;  $T_{jstart} = 150^{\circ}\text{C}$ ,  $V_{bb} = 12\text{V}$ ,  $R_L = 0\Omega$



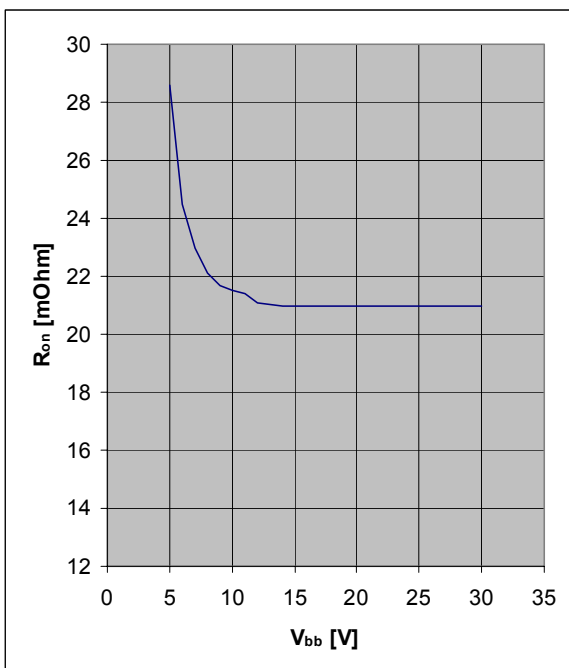
**Typ. standby current**

$I_{bb(off)} = f(T_j)$ ;  $V_{bb} = 16\text{V}$ ;  $V_{IN1,2} = \text{low}$



**Typ. on-state resistance**

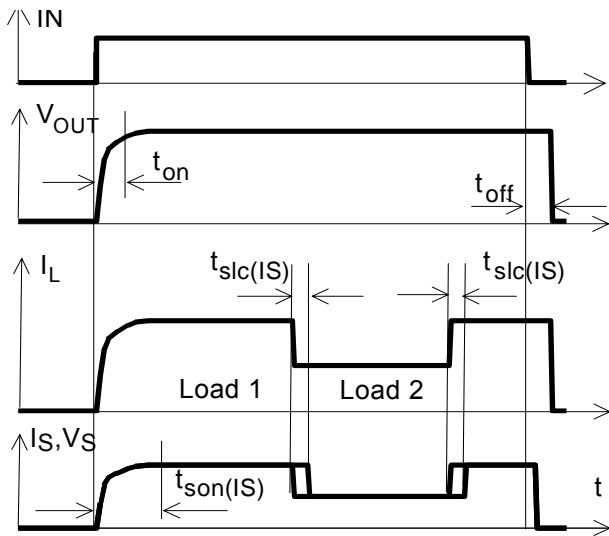
$R_{ON} = f(V_{bb}, T_j)$ ;  $I_L = 5\text{A}$ ;  $V_{in} = \text{high}$



**Timing diagrams**

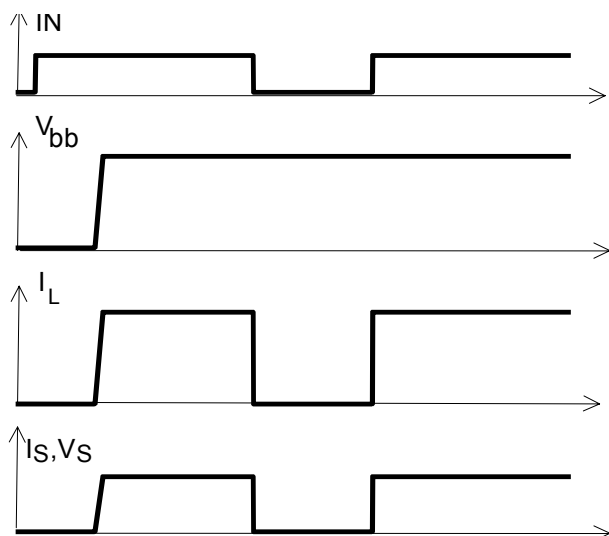
All channels are symmetric and consequently the diagrams are valid for channel 1 and channel 2.

**Figure 1a:** Switching a resistive load, change of load current in on-condition



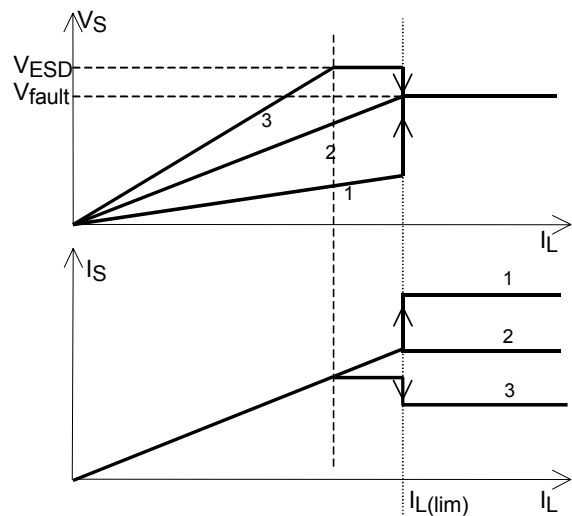
The sense signal is not valid during settling time after turn on or change of load current.  $t_{slc}(I_S) = 300 \mu s$  typ.

**Figure 1b:**  $V_{bb}$  turn on



proper turn on under all conditions

**Figure 1c:** Behaviour of sense output: Sense current ( $I_S$ ) and sense voltage ( $V_S$ ) as function of load current dependent on the sense resistor. Shown is  $V_S$  and  $I_S$  for three different sense resistors. Curve 1 refers to a low resistor, curve 2 to a medium-sized resistor and curve 3 to a big resistor. Note, that the sense resistor may not falls short of a minimum value of  $500 \Omega$ .

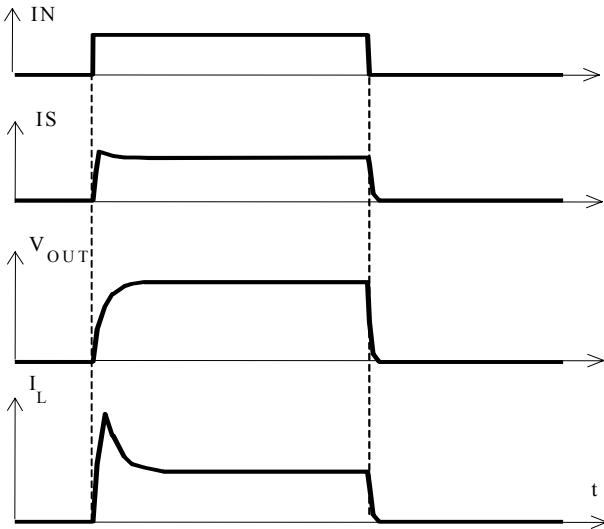


$$I_S = I_L / k_{ILIS}$$

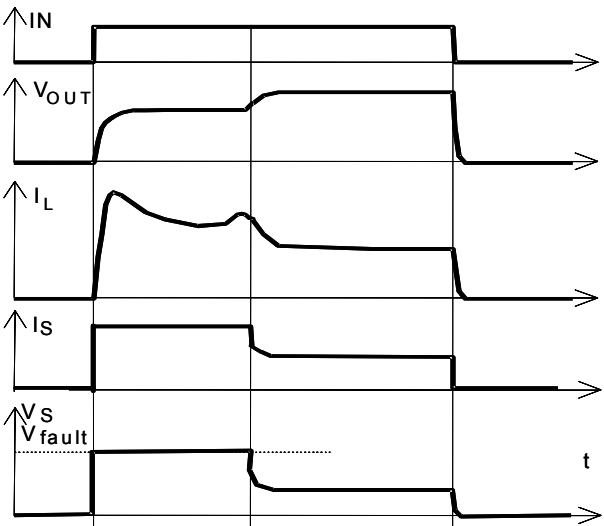
$$V_{IS} = I_S * R_{IS}; R_{IS} = 1k\Omega \text{ nominal}$$

$$R_{IS} > 500\Omega$$

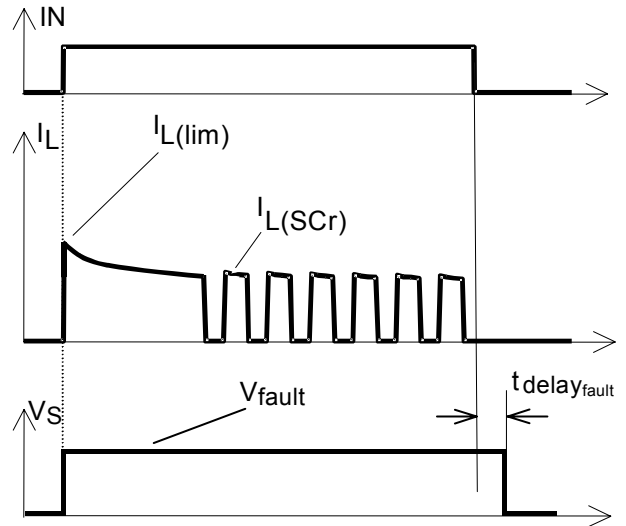
**Figure 2a:** Switching a lamp



**Figure 2b:** Switching a lamp with current limit: The behaviour of  $I_S$  and  $V_S$  is shown for a resistor, which refers to curve 1 in figure 1c

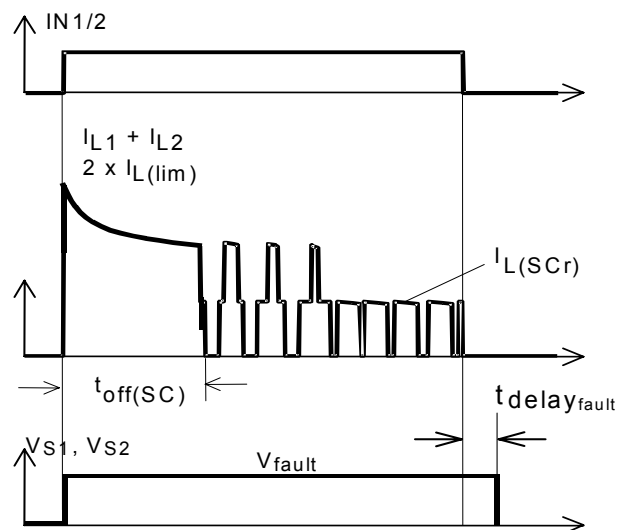


**Figure 3a:** Short circuit: Shut down by overtemperature, reset by cooling



Heating up may require several milliseconds, depending on external conditions.  
 $I_{L(lim)} = 50A$  typ. increases with decreasing temperature.

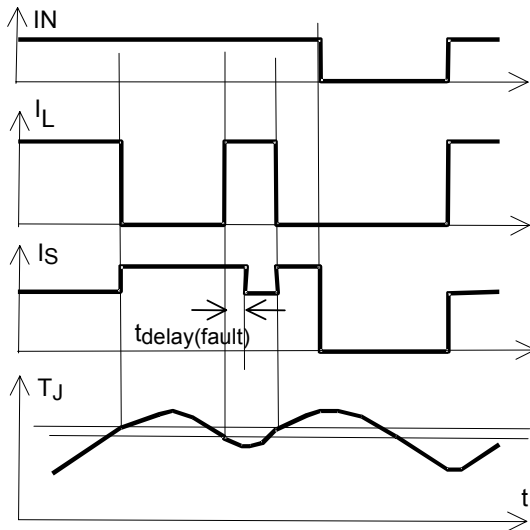
**Figure 3a:** Turn on into short circuit, shut down by overtemperature, restart by cooling ( channel 1 and 2 switched parallel )



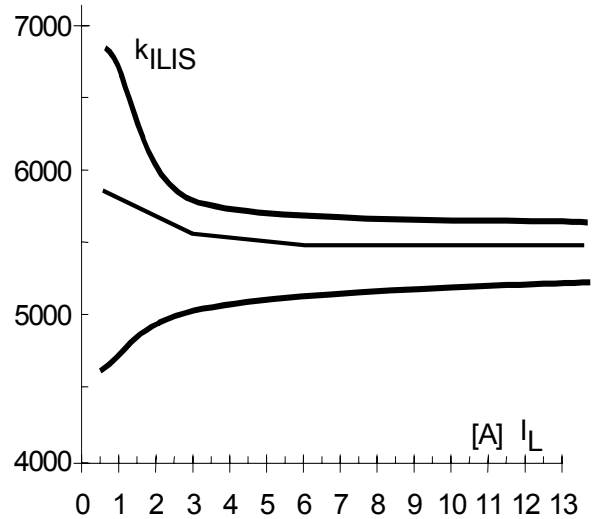
**Figure 4a: Overtemperature**

Reset if  $T_j < T_{jt}$

The behaviour of  $I_S$  and  $V_S$  is shown for a resistor, which refers to curve 1 in figure 1c.

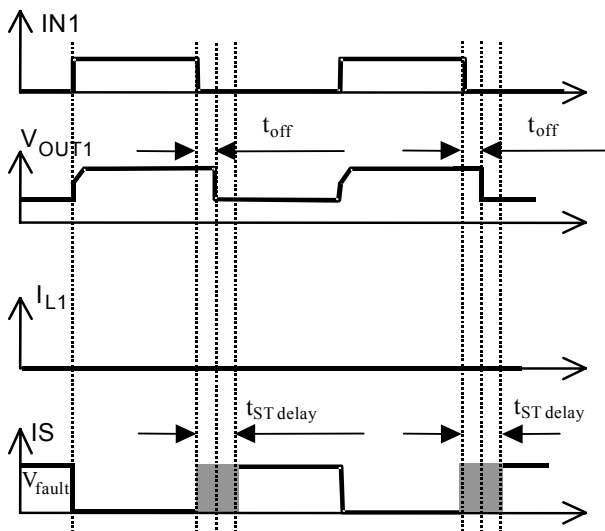


**Figure 6b: Current sense ratio<sup>1)</sup>**



**Figure 5a: Open-load: detection in OFF-state, turn on/off to open load.**

Open load of channel 1; other channels normal operation.



$t_{off} = 250\mu s$  max.;  $t_{ST\ delay} = 500\mu s$  max.

with pull up resistor at output

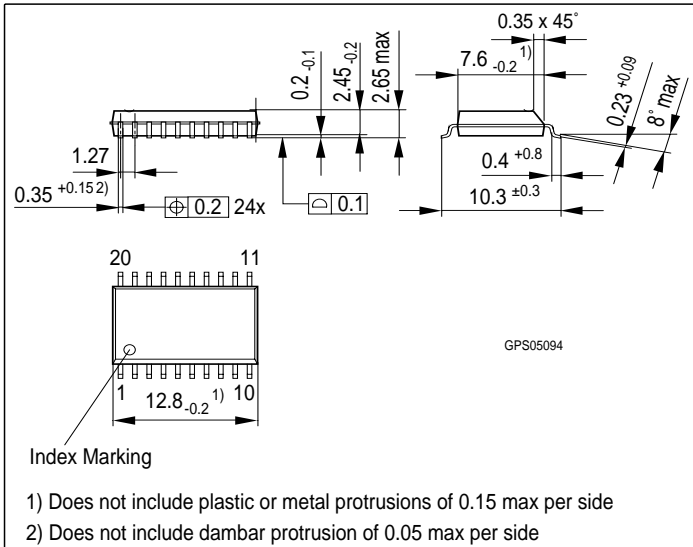
<sup>1)</sup>This range for the current sense ratio refers to all devices. The accuracy of the  $k_{ILIS}$  can be raised by calibrating the value of  $k_{ILIS}$  for every single device.

**Package and ordering code**

all dimensions in mm

**P-DSO-20-21**

Sales Code	BTS 5240G
Ordering Code	Q67060-S6145



**Published by**  
**Infineon Technologies AG,**  
**St.-Martin-Strasse 53,**  
**D-81669 München**  
 © Infineon Technologies AG 2001  
**All Rights Reserved.**

**Attention please!**

The information herein is given to describe certain components and shall not be considered as a guarantee of characteristics.

Terms of delivery and rights to technical change reserved.

We hereby disclaim any and all warranties, including but not limited to warranties of non-infringement, regarding circuits, descriptions and charts stated herein.

Infineon Technologies is an approved CECC manufacturer.

**Information**

For further information on technology, delivery terms and conditions and prices please contact your nearest Infineon Technologies Office in Germany or our Infineon Technologies Representatives worldwide (see address list).

**Warnings**

Due to technical requirements components may contain dangerous substances. For information on the types in question please contact your nearest Infineon Technologies Office.

Infineon Technologies Components may only be used in life-support devices or systems with the express written approval of Infineon Technologies, if a failure of such components can reasonably be expected to cause the failure of that life-support device or system, or to affect the safety or effectiveness of that device or system. Life support devices or systems are intended to be implanted in the human body, or to support and/or maintain and sustain and/or protect human life. If they fail, it is reasonable to assume that the health of the user or other persons may be endangered.



LittleDiode supplies new, hard to find or obsolete electronic components and semiconductors all over the world.

With over two million different components listed you are sure to find the part you need.

Feel free to visit us today at our online store:

[LittleDiode.com](http://LittleDiode.com)

Looking forward to providing you with the best possible service.