

Smart Two Channel Highside Power Switch

Features

- Overload protection
- Current limitation
- Short-circuit protection
- Thermal shutdown
- Overvoltage protection
- Fast demagnetization of inductive loads
- Reverse battery protection¹⁾
- Open drain diagnostic output
- Open load detection in OFF-state
- CMOS compatible input
- Loss of ground and loss of V_{bb} protection
- Electrostatic discharge (ESD) protection

Product Summary

Overvoltage Protection	$V_{bb(AZ)}$	65	V
Operating voltage	$V_{bb(on)}$	5.8 ... 58	V
	active channels:	one	two parallel
On-state resistance	R_{ON}	250	125
Nominal load current	$I_{L(NOM)}$	1.9	2.8
			mΩ
			A

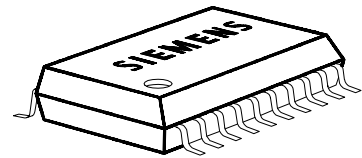

Application

- μ C compatible power switch with diagnostic feedback for 12 V and 24 V DC grounded loads
- Most suitable for inductive loads
- Replaces electromechanical relays, fuses and discrete circuits

General Description

N channel vertical power FET with charge pump, ground referenced CMOS compatible input and diagnostic feedback, monolithically integrated in Smart SIPMOS® technology.

Providing embedded protective functions.

Pin Definitions and Functions

Pin	Symbol	Function
1,10, 11,12, 15,16, 19,20	V_{bb}	Positive power supply voltage. Design the wiring for the simultaneous max. short circuit currents from channel 1 to 2 and also for low thermal resistance
3	IN1	Input 1,2 , activates channel 1,2 in case of logic high signal
7	IN2	
17,18	OUT1	Output 1,2 , protected high-side power output of channel 1,2. Design the wiring for the max. short circuit current
13,14	OUT2	
4	ST1	Diagnostic feedback 1,2 of channel 1,2, open drain, low in on state on failure or high in off state on failure
8	ST2	
2	GND1	Ground 1 of chip 1 (channel 1)
6	GND2	Ground 2 of chip 2 (channel 2)
5,9	N.C.	Not Connected

Pin configuration (top view)

V_{bb}	1	20	V_{bb}
GND1	2	19	V_{bb}
IN1	3	18	OUT1
ST1	4	17	OUT1
N.C.	5	16	V_{bb}
GND2	6	15	V_{bb}
IN2	7	14	OUT2
ST2	8	13	OUT2
N.C.	9	12	V_{bb}
V_{bb}	10	11	V_{bb}

¹⁾ With external current limit (e.g. resistor $R_{GND}=150 \Omega$) in GND connection, resistor in series with ST connection, reverse load current limited by connected load.

Block diagram

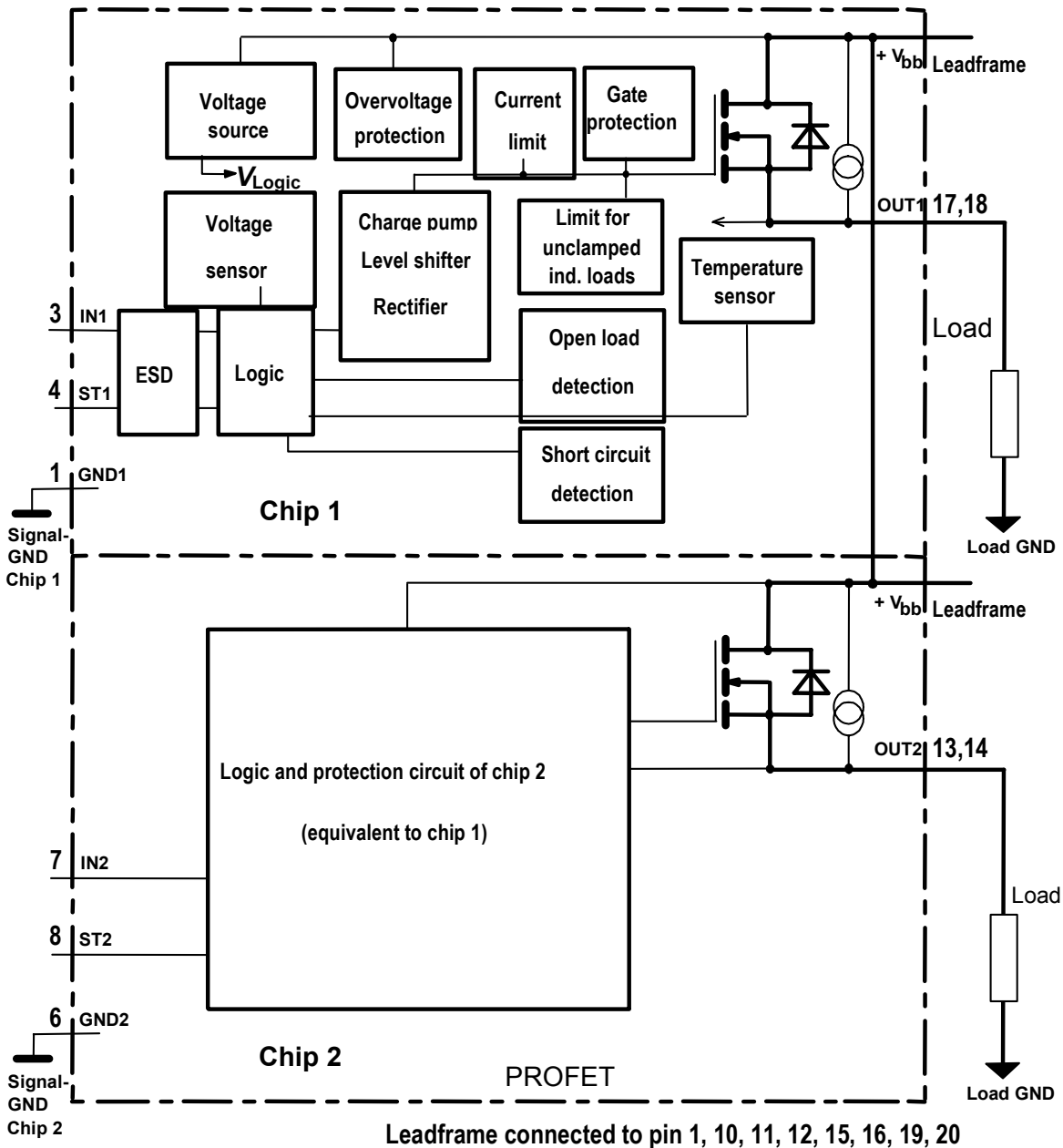

Maximum Ratings at $T_j = 25^\circ\text{C}$ unless otherwise specified

Parameter	Symbol	Values	Unit
Supply voltage (overvoltage protection see page 4)	V_{bb}	65	V
Supply voltage for full short circuit protection $T_{j,start} = -40 \dots +150^\circ\text{C}$	V_{bb}	40	V
Load current (Short-circuit current, see page 5)	I_L	self-limited	A
Operating temperature range	T_j	$-40 \dots +150$	$^\circ\text{C}$
Storage temperature range	T_{stg}	$-55 \dots +150$	

Maximum Ratings at $T_j = 25^\circ\text{C}$ unless otherwise specified

Parameter	Symbol	Values	Unit
Power dissipation (DC) ²⁾ (all channels active)	$T_a = 25^\circ\text{C}$: $T_a = 85^\circ\text{C}$:	P_{tot}	3 1.6 W
Electrostatic discharge capability (ESD) (Human Body Model)	IN, ST: all other pins:	V_{ESD}	1.0 1.0 kV
Input voltage (DC)		V_{IN}	-0.5 ... +36 V
Current through input pin (DC)		I_{IN}	± 2.0 mA
Current through status pin (DC) see internal circuit diagram page 7		I_{ST}	± 5.0 mA

Thermal Characteristics

Parameter and Conditions	Symbol	Values			Unit
		min	typ	max	
Thermal resistance junction - soldering point ^{2),3)}	each channel: R_{thjs}	--	--	18	K/W
junction - ambient ²⁾	one channel active: R_{thja}	--	45	--	
	all channels active:	--	37	--	

Electrical Characteristics

Parameter and Conditions, each of the two channels at $T_j = 25^\circ\text{C}$, $V_{\text{bb}} = 12\text{ V}$ unless otherwise specified	Symbol	Values			Unit
		min	typ	max	

Load Switching Capabilities and Characteristics

On-state resistance (V_{bb} to OUT) $I_L = 2\text{ A}$ $V_{\text{bb}} = 24\text{ V}$	each channel, $T_j = 25^\circ\text{C}$: $T_j = 150^\circ\text{C}$: two parallel channels, $T_j = 25^\circ\text{C}$:	R_{ON}	--	225 400 113	250 500 125	m Ω
Nominal load current Device on PCB ²⁾ , $T_a = 85^\circ\text{C}$, $T_j \leq 150^\circ\text{C}$	one channel active: two parallel channels active:	$I_{\text{L(NOM)}}$	1.60 2.4	1.9 2.8	--	A
Output current while GND disconnected or pulled up; $V_{\text{bb}} = 32\text{ V}$, $V_{\text{IN}} = 0$, see diagram page 8		$I_{\text{L(GNDhigh)}}$	--	--	1.1	mA

2) Device on 50mm*50mm*1.5mm epoxy PCB FR4 with 6cm² (one layer, 70 μm thick) copper area for V_{bb} connection. PCB is vertical without blown air. See page 12

3) Soldering point: upper side of solder edge of device pin 15. See page 12

Parameter and Conditions, each of the two channels at $T_j = 25^\circ\text{C}$, $V_{bb} = 12\text{ V}$ unless otherwise specified	Symbol	Values			Unit
		min	typ	max	
Turn-on time to 90% V_{OUT} :	t_{on}	15	--	80	μs
Turn-off time to 10% V_{OUT} : $R_L = 12\ \Omega$, $V_{bb} = 20\text{ V}$, $T_j = -40\dots+150^\circ\text{C}$	t_{off}	20	--	70	
Slew rate on 10 to 30% V_{OUT} , $R_L = 12\ \Omega$, $V_{bb} = 20\text{ V}$, $T_j = -40\dots+150^\circ\text{C}$:	dV/dt_{on}	--	--	6	$\text{V}/\mu\text{s}$
Slew rate off 70 to 40% V_{OUT} , $R_L = 12\ \Omega$, $V_{bb} = 20\text{ V}$, $T_j = -40\dots+150^\circ\text{C}$:	$-dV/dt_{off}$	--	--	7	$\text{V}/\mu\text{s}$

Operating Parameters

Operating voltage ⁴⁾	$T_j = -40\dots+150^\circ\text{C}$:	$V_{bb(on)}$	5.8	--	58	V
Undervoltage shutdown	$T_j = -40\dots+150^\circ\text{C}$:	$V_{bb(under)}$	2.7	--	4.7	V
Undervoltage restart	$T_j = -40\dots+150^\circ\text{C}$:	$V_{bb(u\ rst)}$	--	--	4.9	V
Undervoltage restart of charge pump see diagram page 10	$T_j = -40\dots+150^\circ\text{C}$:	$V_{bb(ucp)}$	--	5.6	7.5	V
Undervoltage hysteresis $\Delta V_{bb(under)} = V_{bb(u\ rst)} - V_{bb(under)}$		$\Delta V_{bb(under)}$	--	0.4	--	V
Overvoltage protection ⁵⁾ $I_{bb} = 40\text{ mA}$	$T_j = -40\dots+150^\circ\text{C}$:	$V_{bb(AZ)}$	65	70	--	V
Standby current, all channels off $V_{IN} = 0$	$T_j = 150^\circ\text{C}$:	$I_{bb(off)}$	--	20	70	μA
Operating current ⁶⁾ , $V_{IN} = 5\text{V}$, $T_j = -40\dots+150^\circ\text{C}$ $I_{GND} = I_{GND1} + I_{GND2}$, one channel on: two channels on:		I_{GND}	--	2.2	--	mA
			--	4.4	--	

Protection Functions⁷⁾

Initial peak short circuit current limit, (see timing diagrams, page 9)						
each channel, $T_j = -40^\circ\text{C}$:	$I_{L(SCp)}$	--	--	19	A	
$T_j = 25^\circ\text{C}$:		--	10	--		
$T_j = +150^\circ\text{C}$:		4.0	--	--		
two parallel channels		twice the current of one channel				
Output clamp (inductive load switch off) ⁸⁾ at $V_{ON(CL)} = V_{bb} - V_{OUT}$	$V_{ON(CL)}$	59	--	75	V	
Thermal overload trip temperature	T_{jt}	150	--	--	$^\circ\text{C}$	
Thermal hysteresis	ΔT_{jt}	--	10	--	K	

4) At supply voltage increase up to $V_{bb} = 5.6\text{ V}$ typ without charge pump, $V_{OUT} \approx V_{bb} - 2\text{ V}$

5) see also $V_{ON(CL)}$ in circuit diagram on page 7.

6) Add I_{ST} , if $I_{ST} > 0$

7) Integrated protection functions are designed to prevent IC destruction under fault conditions described in the data sheet. Fault conditions are considered as "outside" normal operating range. Protection functions are not designed for continuous repetitive operation.

8) If channels are connected in parallel, output clamp is usually accomplished by the channel with the lowest $V_{ON(CL)}$

Parameter and Conditions, each of the two channels at $T_j = 25\text{ °C}$, $V_{bb} = 12\text{ V}$ unless otherwise specified	Symbol	Values			Unit
		min	typ	max	



Reverse Battery

Reverse battery voltage ⁹⁾	$-V_{bb}$	--	--	32	V
---------------------------------------	-----------	----	----	----	---

Diagnostic Characteristics

Open load detection current	$I_{L(off)}$	--	6	--	μA
Open load detection voltage $T_j = -40..+150\text{ °C}$:	$V_{OUT(OL)}$	2.4	3	4	V
Short circuit detection voltage (pin 3 to 5)	$V_{ON(SC)}$	--	2.5	--	V

Input and Status Feedback¹⁰⁾

Input resistance (see circuit page 7)	R_i	--	20	--	$\text{k}\Omega$
Input turn-on threshold voltage 	$V_{IN(T+)}$	1	--	2.5	V
Input turn-off threshold voltage 	$V_{IN(T-)}$	0.8	--	--	V
Input threshold hysteresis	$\Delta V_{IN(T)}$	--	0.5	--	V
Off state input current $V_{IN} = 0.4\text{ V}$:	$I_{IN(off)}$	1	--	30	μA
On state input current $V_{IN} = 2.5\text{ V}$:	$I_{IN(on)}$	10	25	70	μA
Delay time for status with open load (see timing diagrams, page 10)	$t_{d(ST\ OL3)}$	--	200	--	μs
Status output (open drain)					
Zener limit voltage $T_j = -40...+150\text{ °C}$, $I_{ST} = +1.6\text{ mA}$:	$V_{ST(high)}$	5.4	6.1	--	V
ST low voltage $T_j = -40...+150\text{ °C}$, $I_{ST} = +1.6\text{ mA}$:	$V_{ST(low)}$	--	--	0.4	

⁹⁾ Requires a $150\ \Omega$ resistor in GND connection. The reverse load current through the intrinsic drain-source diode has to be limited by the connected load. Note that the power dissipation is higher compared to normal operating conditions due to the voltage drop across the intrinsic drain-source diode. The temperature protection is not active during reverse current operation! Input and Status currents have to be limited (see max. ratings page 3 and circuit page 7).

¹⁰⁾ If ground resistors R_{GND} are used, add the voltage drop across these resistors.

Truth Table

Channel 1	Input 1	Output 1	Status 1
Channel 2	Input 2	Output 2	Status 2
	level	level	BTS 707
Normal operation	L	L	L
	H	H	H
Open load	L	Z	H
	H	H	H
Short circuit to GND	L	L	L
	H	L	L
Short circuit to V_{bb}	L	H	H
	H	H	H
Overt-temperature	L	L	L
	H	L	L
Under-voltage	L	L	L
	H	L	L
Overvoltage	no overvoltage shutdown, see normal operation		

Parallel switching of channel 1 and 2 is easily possible by connecting the inputs and outputs in parallel. The status outputs ST1 and ST2 have to be configured as a 'Wired OR' function with a single pull-up resistor.

Terms

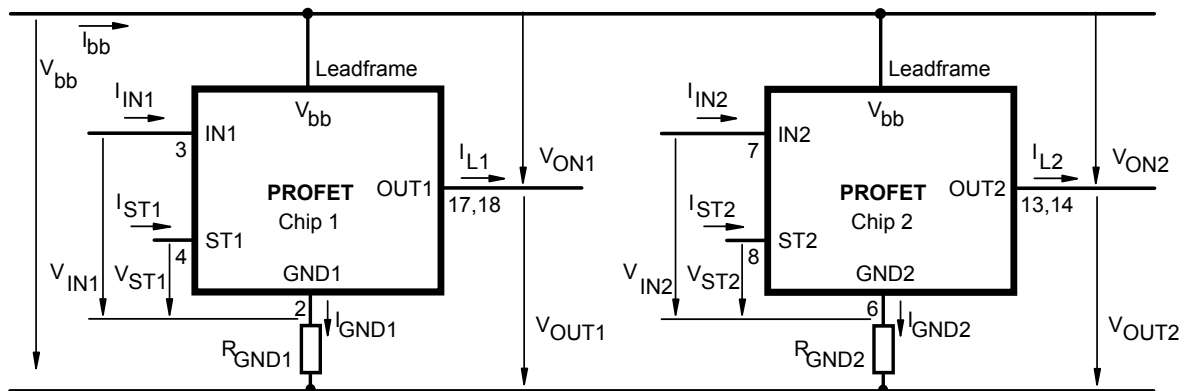

Leadframe (V_{bb}) is connected to pin 1,10,11,12,15,16,19,20

External R_{GND} optional; two resistors R_{GND1} , $R_{GND2} = 150 \Omega$ or a single resistor $R_{GND} = 75 \Omega$ for reverse battery protection up to the max. operating voltage.

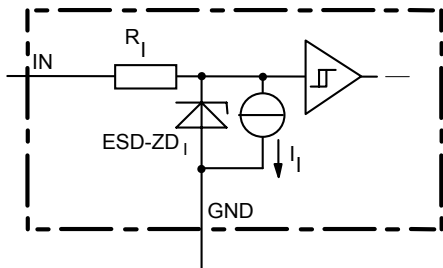
Input circuit (ESD protection), IN1 or IN2

ESD zener diodes are not to be used as voltage clamp at DC conditions. Operation in this mode may result in a drift of the zener voltage (increase of up to 1 V).

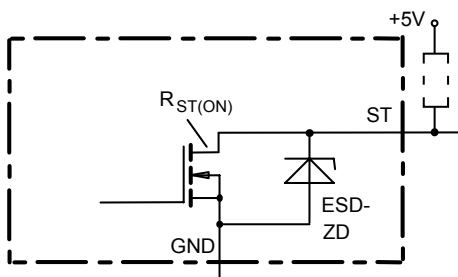
Status output, ST1 or ST2

ESD-Zener diode: 6.1 V typ., max 5.0 mA; $R_{ST(ON)} < 0 \Omega$ at 1.6 mA, ESD zener diodes are not to be used as voltage clamp at DC conditions. Operation in this mode may result in a drift of the zener voltage (increase of up to 1 V).

Short Circuit detection

Fault Signal at ST-Pin: $V_{ON} > 2.5 \text{ V}$ typ., no switch off by the PROFET itself, external switch off recommended!

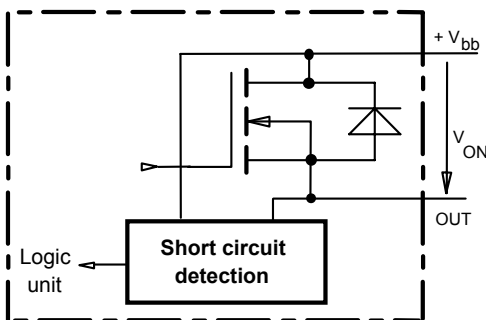
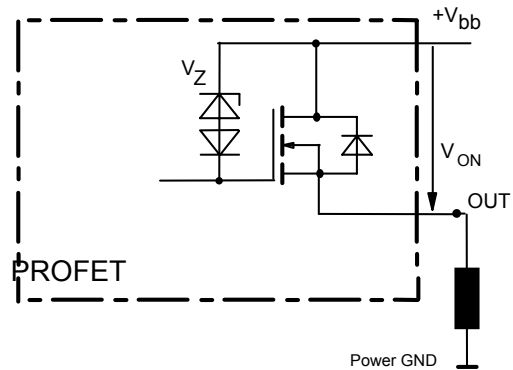
Inductive and overvoltage output clamp, OUT1 or OUT2

V_{ON} clamped to $V_{ON(CL)} = -V$ typ.

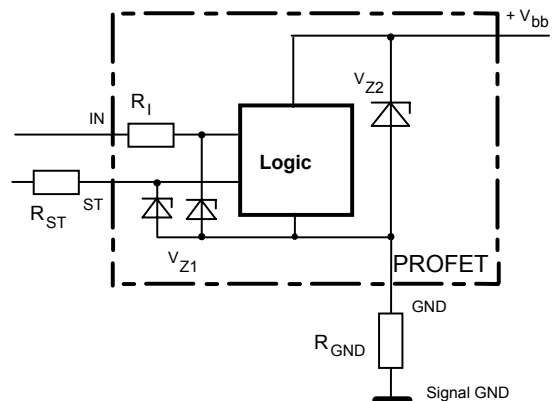
Overvoltage protection of logic part GND1 or GND2

$V_{Z1} = 6.1 \text{ V}$ typ., $V_{Z2} = 70 \text{ V}$ typ., $R_1 = 20 \text{ k}\Omega$ typ., $R_{GND} = 150 \Omega$, $R_{ST} = 15 \text{ k}\Omega$ nominal.

Open-load detection, OUT1 or OUT2

OFF-state diagnostic condition:

$V_{OUT} > 3 \text{ V}$ typ.; IN low

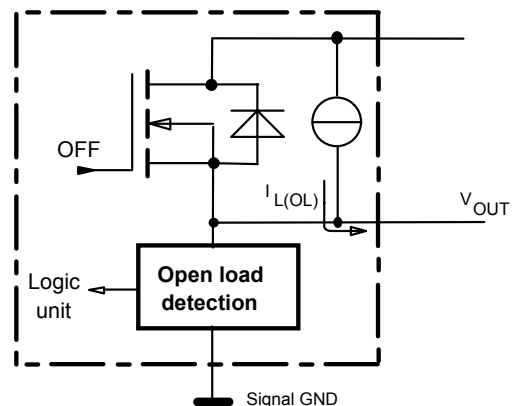

GND disconnect

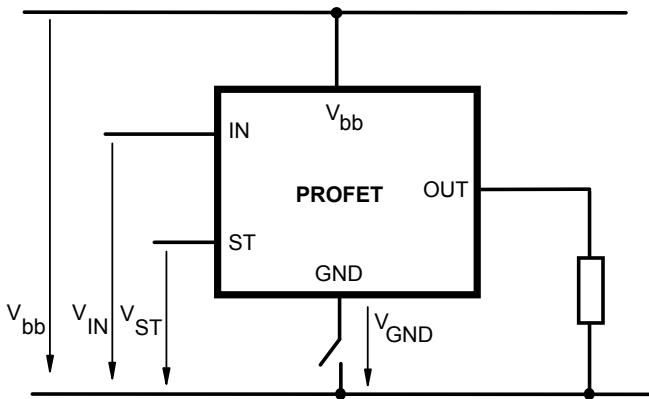

Any kind of load. In case of IN=high is $V_{OUT} \approx V_{IN} - V_{IN(T+)}$.
Due to $V_{GND} > 0$, no $V_{ST} = \text{low}$ signal available.

GND disconnect with GND pull up

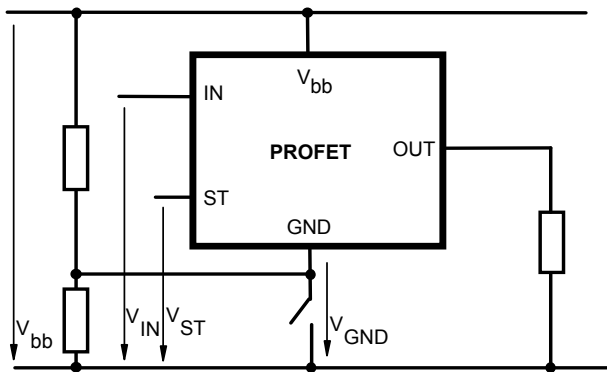

Any kind of load. If $V_{GND} > V_{IN} - V_{IN(T+)}$ device stays off
Due to $V_{GND} > 0$, no $V_{ST} = \text{low}$ signal available.

Vbb disconnect with energized inductive load

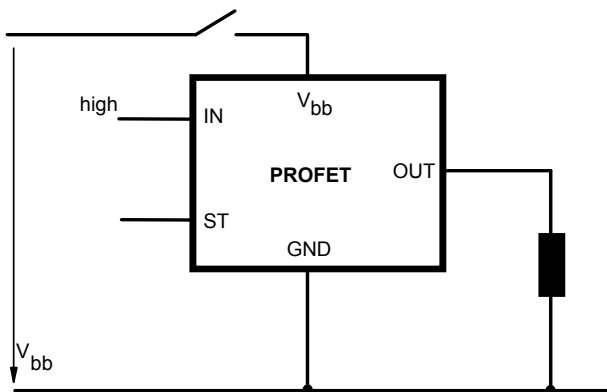

For an inductive load current up to the limit defined by E_{AS} (max. ratings) each switch is protected against loss of V_{bb} .
Consider at your PCB layout that in the case of V_{bb} disconnection with energized inductive load the whole load current flows through the GND connection.

Inductive load switch-off energy dissipation

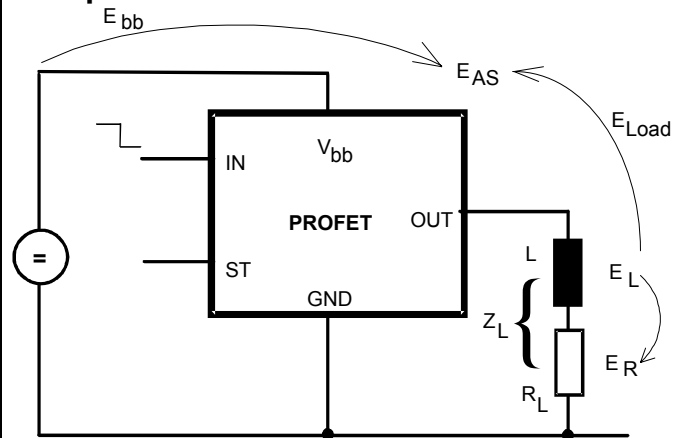

Energy stored in load inductance:

$$E_L = \frac{1}{2} \cdot L \cdot I_L^2$$

While demagnetizing load inductance, the energy dissipated in PROFET is

$$E_{AS} = E_{bb} + E_L - E_R = V_{ON(CL)} \cdot i_L(t) dt,$$

with an approximate solution for $R_L > 0\Omega$:

$$E_{AS} = \frac{I_L \cdot L}{2 \cdot R_L} (V_{bb} + |V_{OUT(CL)}|) \ln \left(1 + \frac{I_L \cdot R_L}{|V_{OUT(CL)}|} \right)$$

Timing diagrams

Both channels are symmetric and consequently the diagrams are valid for channel 1 and channel 2

Figure 1a: V_{bb} turn on, :

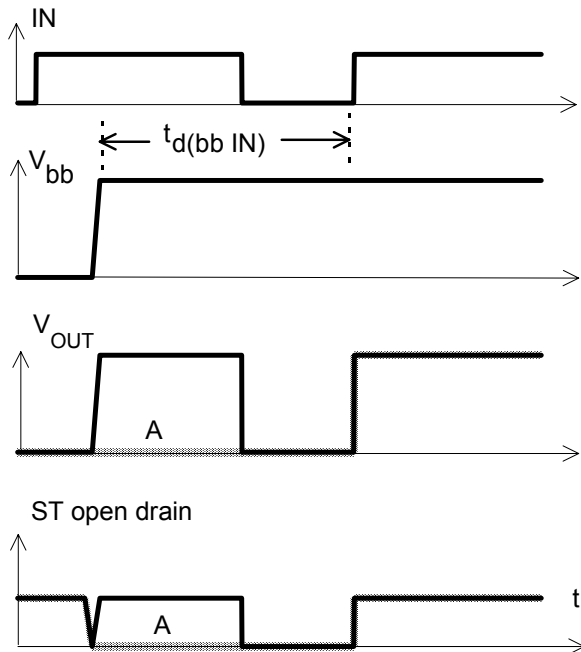

in case of too early V_{IN} =high the device may not turn on (curve A)
 $t_{d(bb IN)}$ approx. 150 μ s

Figure 2a: Switching an inductive load

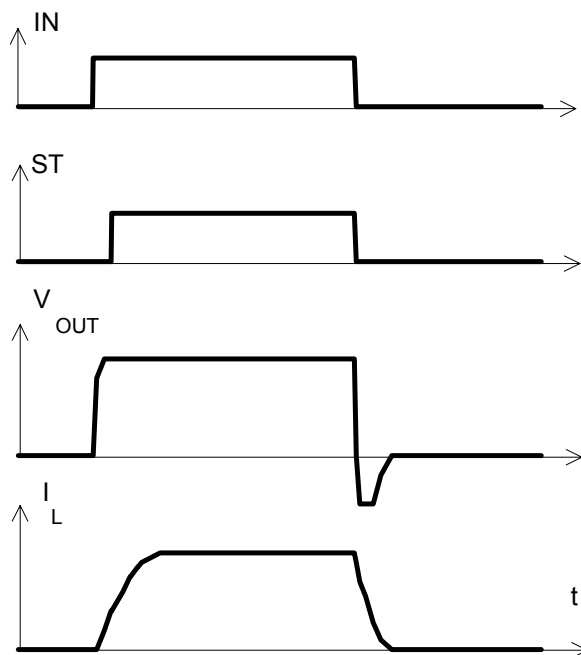
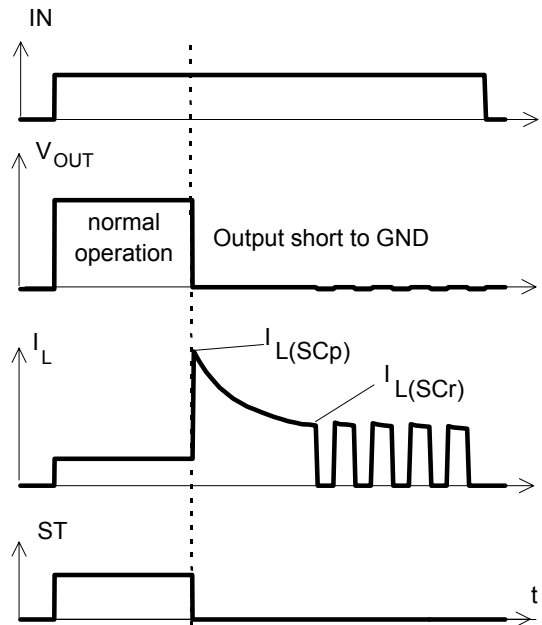

Figure 3a: Short circuit:
 shut down by overtemperature, reset by cooling



Heating up requires several milliseconds, depending on external conditions. External shutdown in response to status fault signal recommended.

Figure 4a: Overtemperature:
 Reset if $T_j < T_{jt}$

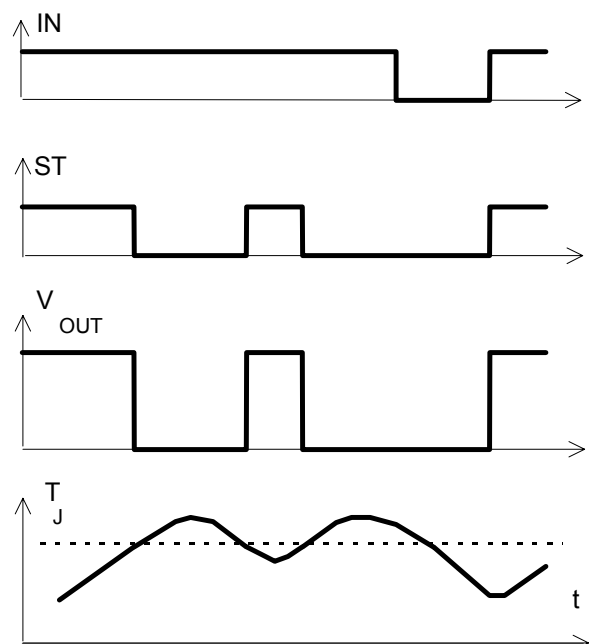
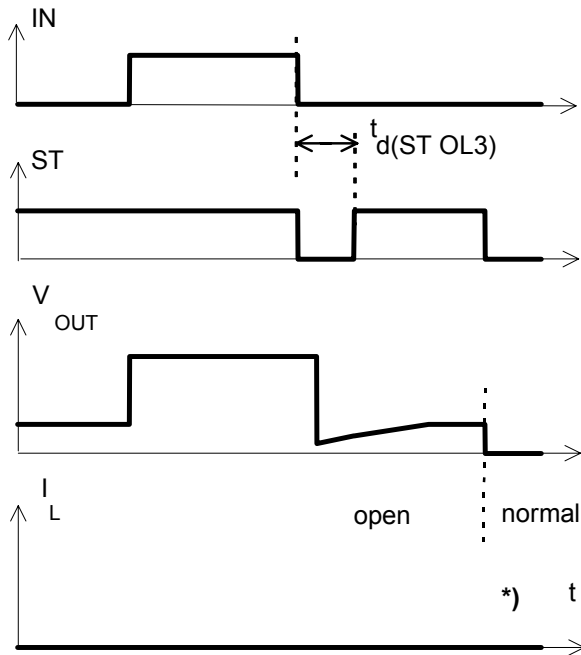

Figure 5a: Open load, : detection in OFF-state, turn on/off to open load



$t_{d(ST,OL3)}$ depends on external circuitry because of high impedance

*) $I_L = 6 \mu A$ typ

Figure 5b: Open load, : detection in OFF-state, open load occurs in off-state

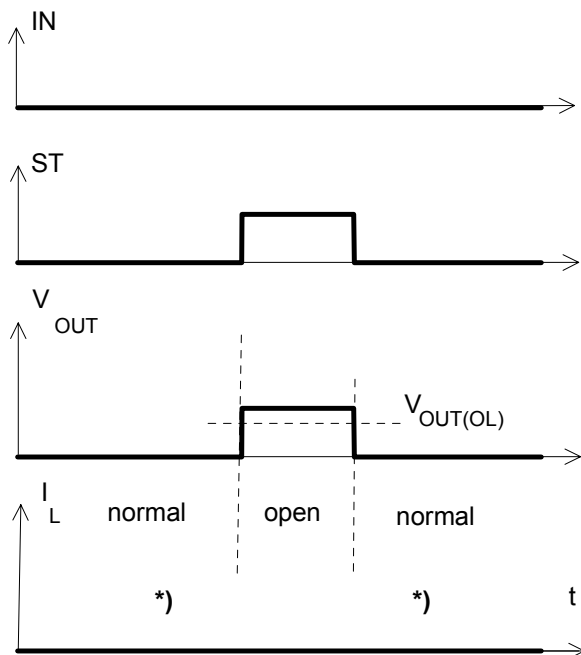

*) $I_L = 6 \mu A$ typ

Figure 6a: Undervoltage:

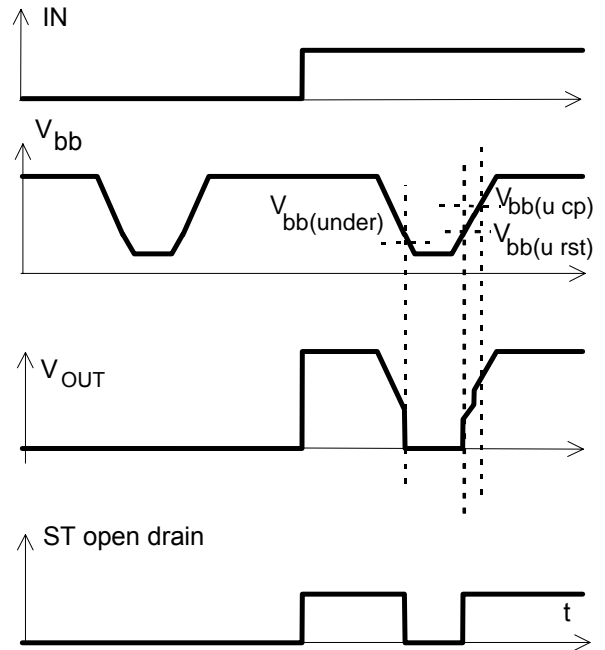
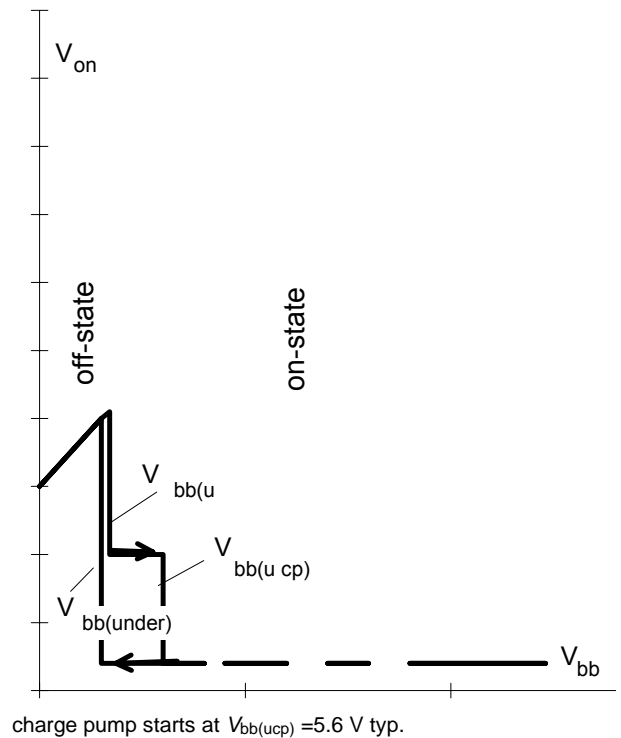
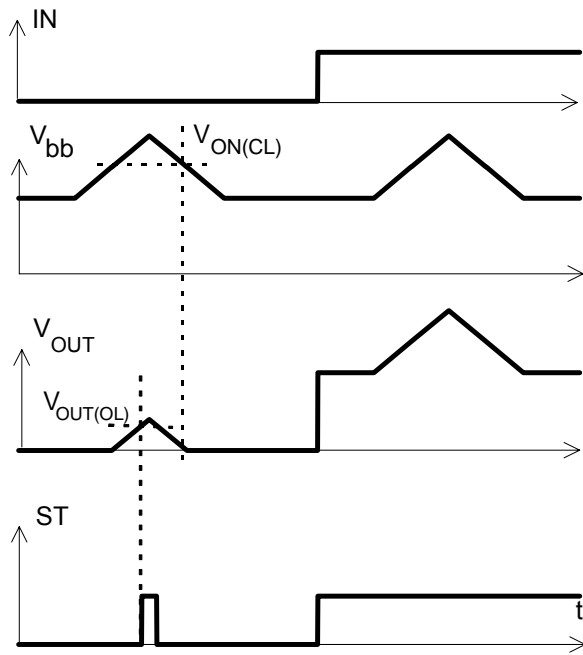

Figure 6b: Undervoltage restart of charge pump



charge pump starts at $V_{bb(ucp)} = 5.6 V$ typ.

Figure 7a: Overvoltage, no shutdown:



Package and Ordering Code

Standard P-DSO-20-9 Ordering Code

BTS 707	Q67060-S7010-A2
---------	-----------------

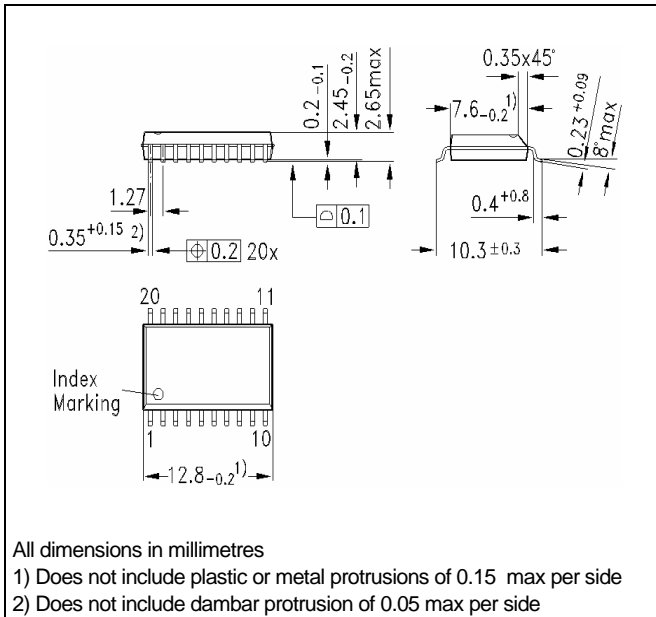

Definition of soldering point with temperature T_S :
 upper side of solder edge of device pin 15.

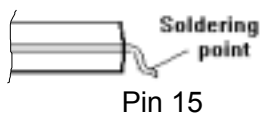

Printed circuit board (FR4, 1.5mm thick, one layer
 $70\mu\text{m}$, 6cm^2 active heatsink area) as a reference for
 max. power dissipation P_{tot} , nominal load current
 $I_{L(\text{NOM})}$ and thermal resistance R_{thja}

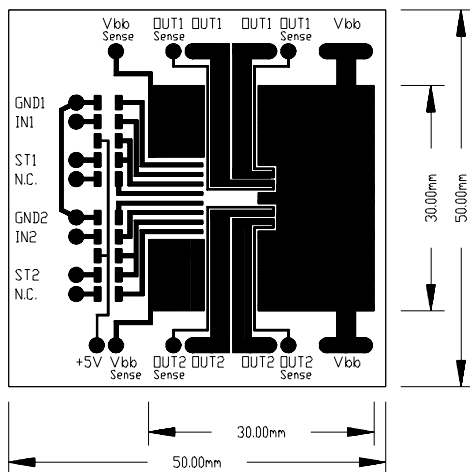

Published by
Infineon Technologies AG,
St.-Martin-Strasse 53,
D-81669 München
 © Infineon Technologies AG 2001
All Rights Reserved.

Attention please!

The information herein is given to describe certain components and shall not be considered as a guarantee of characteristics.

Terms of delivery and rights to technical change reserved.

We hereby disclaim any and all warranties, including but not limited to warranties of non-infringement, regarding circuits, descriptions and charts stated herein.

Infineon Technologies is an approved CECC manufacturer.

Information

For further information on technology, delivery terms and conditions and prices please contact your nearest Infineon Technologies Office in Germany or our Infineon Technologies Representatives worldwide (see address list).

Warnings

Due to technical requirements components may contain dangerous substances. For information on the types in question please contact your nearest Infineon Technologies Office.

Infineon Technologies Components may only be used in life-support devices or systems with the express written approval of Infineon Technologies, if a failure of such components can reasonably be expected to cause the failure of that life-support device or system, or to affect the safety or effectiveness of that device or system. Life support devices or systems are intended to be implanted in the human body, or to support and/or maintain and sustain and/or protect human life. If they fail, it is reasonable to assume that the health of the user or other persons may be endangered.



LittleDiode supplies new, hard to find or obsolete electronic components and semiconductors all over the world.

With over two million different components listed you are sure to find the part you need.

Feel free to visit us today at our online store:

LittleDiode.com

Looking forward to providing you with the best possible service.