

Overview

Features

- Quad switch driver
- Free configurable as bridge or quad-switch
- Optimized for DC motor management applications
- Ultra low $R_{DS\ ON}$ @ 25 °C:
 - High-side switch: typ. 165 mΩ,
 - Low-side switch: typ. 55 mΩ
- Very high peak current capability
- Very low quiescent current
- Space- and thermal optimized power P-DSO-Package
- Load and GND-short-circuit-protected
- Operates up to 40 V
- Status flag diagnosis
- Overtemperature shut down with hysteresis
- Short-circuit detection and diagnosis
- Open-load detection and diagnosis
- C-MOS compatible inputs
- Internal clamp diodes
- Isolated sources for external current sensing
- Over- and under-voltage detection with hysteresis

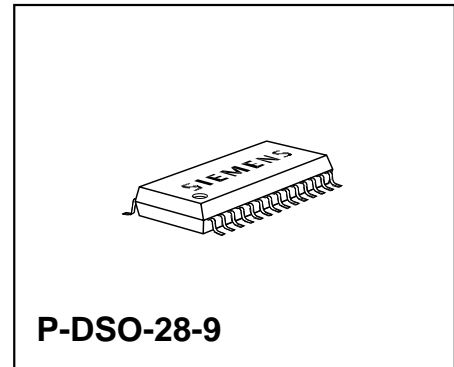

Type	Ordering Code	Package
BTS 770 G	Q67007-A9254	P-DSO-28-9

Description

The **BTS 770 G** is a **TrilithIC** contains one double high-side switch and two low-side switches in **one P-DSO-28-9** -Package.

**“Silicon instead of heatsink”
becomes true**

The ultra low $R_{DS\ ON}$ of this device avoids powerdissipation. It saves costs in mechanical construction and mounting and increases the efficiency.

The high-side switches are produced in the **SIEMENS SMART SIPMOS®** technology. It is fully protected and contains the signal conditioning circuitry for diagnosis. (The comparable standard high-side product is the **BTS 611L1**.)

For minimized $R_{DS\ ON}$ the two low-side switches are produced in the **SIEMENS Millifet** logic level technology (The comparable standard product is the **BUZ 101AL**).

Each drain of these three chips is mounted on separated leadframes (see **P-DSO-28-9** pin configuration). The sources of all four power transistors are connected to separate pins.

So the **BTS 770 G** can be used in H-Bridge configuration as well as in any other switch configuration.

Moreover, it is possible to add current sense resistors.

All these features open a broad range of automotive and industrial applications.

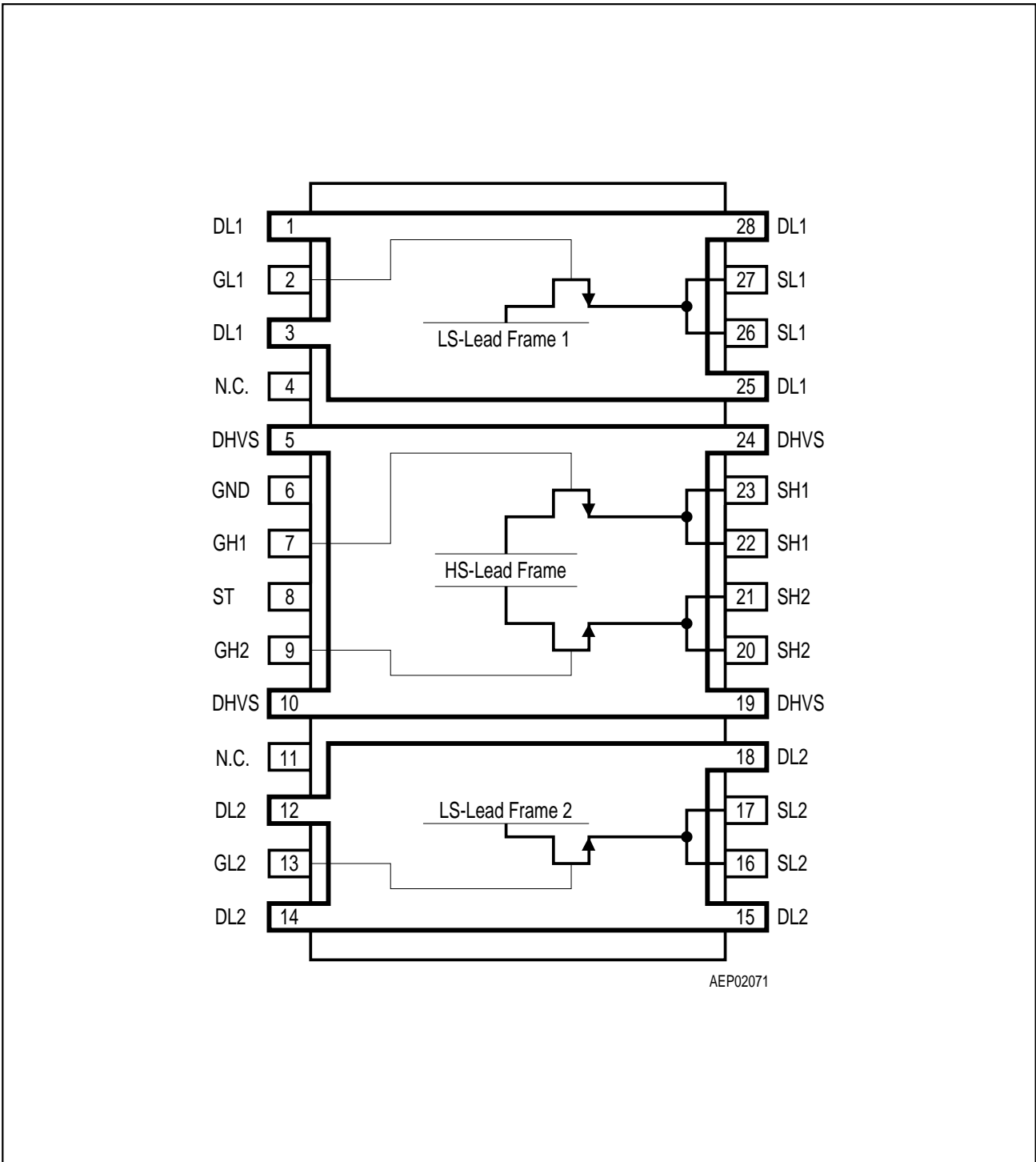

Figure 1 Pin Configuration (top view)

Pin Definitions and Functions

Pin No.	Symbol	Function
1, 3, 25, 28	DL1	Drain of low-side switch1 Leadframe 1 ¹⁾
2	GL1	Gate of low-side switch1
4	N.C.	not connected
5, 10, 19, 24	DHVS	Drain of high-side switches and power supply voltage Leadframe 2 ¹⁾
6	GND	Ground
7	GH1	Gate of high-side switch1
8	ST	Status of high-side switches; open Drain output
9	GH2	Gate of high-side switch2
11	N.C.	not connected
12, 14, 15, 18	DL2	Drain of low-side switch2 Leadframe 3 ¹⁾
13	GL2	Gate of low-side switch2
16, 17	SL2	Source of low-side switch2
20, 21	SH2	Source of high-side switch2
22, 23	SH1	Source of high-side switch1
26, 27	SL1	Source of low-side switch1

¹⁾ To reduce the thermal resistance these pins are direct connected via metal bridges to the leadframe.

Bold type: Pin needs power wiring

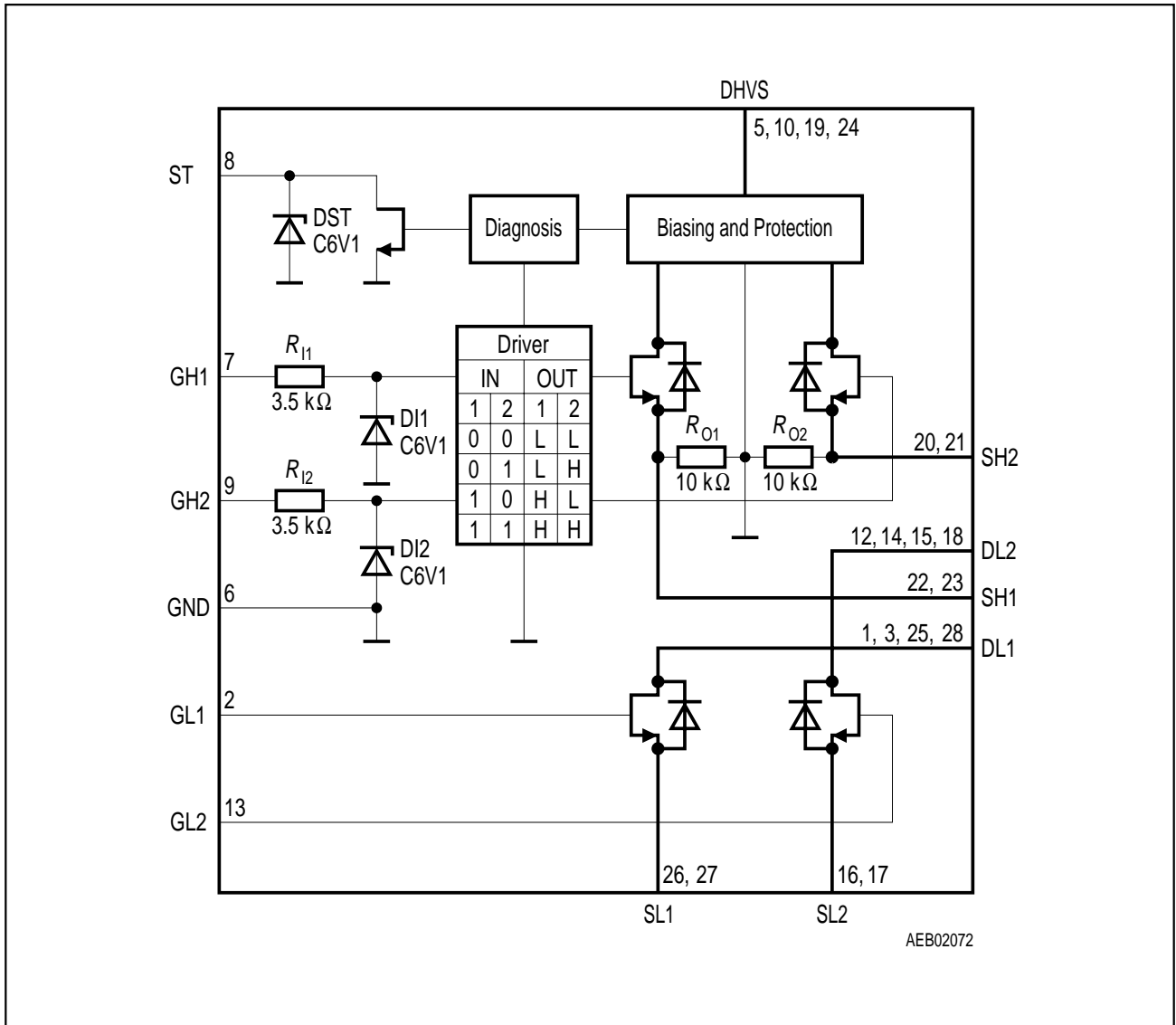

Figure 2 Block Diagram

Circuit Description

Input Circuit

The control inputs GH1,2 consist of TTL/CMOS compatible Schmitt-Triggers with hysteresis. Buffer amplifiers are driven by these stages and convert the logic signal into the necessary form for driving the power output stages.

The inputs GH1 and GH2 are connected to a standard N-channel logic level power-MOS gate.

Output Stages

The output stages consist of an ultra low $R_{DS\ ON}$ Power-MOS H-Bridge. Protective circuits make the outputs short circuit proof to ground and load short circuit proof. Positive and negative voltage spikes, which occur when driving inductive loads, are limited by integrated power clamp diodes.

Short Circuit Protection (valid only for the high-side switches)

The outputs are protected against

- output short circuit to ground, and
- overload (load short circuit).

An internal OP-Amp controls the Drain-Source-Voltage of the HS-Switches by comparing the DS-Voltage-Drop with an internal reference voltage. Above this trippoint the OP-Amp reduces the output current depending on the junction temperature and the drop voltage.

In the case of overloaded high-side switches the status output is set to low.

If the HS-Switches are in OFF-state-Condition internal resistors $R_{O1,2}$ from SH1,2 to GND pull the voltage at SH1,2 to low values. On each output pin SH1 and SH2 an output examiner circuit compares the output voltages with the internal reference voltage VEO. This results in switching the status output to low. In H-Bridge condition this feature can be used to protect the low-side switches against short circuit during the OFF-period.

Overtemperature Protection (valid only for the high-side-switches)

The chip also incorporates an overtemperature protection circuit with hysteresis which switches off the output transistors and sets the status output to low.

Undervoltage-Lockout (UVLO)

When V_S reaches the switch-on voltage V_{UVON} the IC becomes active with a hysteresis. The High-Side output transistors are switched off if the supply voltage V_S drops below the switch off value V_{UVOFF} .

Overvoltage-Lockout (OVLO)

When V_S reaches the switch-off voltage $V_{OV\text{OFF}}$ the High-Side output transistors are switched off with a hysteresis. The IC becomes active if the supply voltage V_S drops below the switch-on value $V_{OV\text{ON}}$.

Open Load Detection

Open load is detected by current measurement. If the output current drops below an internal fixed level the error flag is set with a delay.

Status Flag

Various errors as listed in the table "Diagnosis" are detected by switching the open drain output ST to low.

Truthtable and Diagnosis (valid only for the High-Side-Switches)

Flag	GH1	GH2	SH1	SH2	ST	Remarks	
	Inputs		Outputs				
Normal operation; identical with functional truth table	0	0	L	L	1	stand-by mode switch2 active switch1 active both switches active	
	0	1	L	H	1		
	1	0	H	L	1		
	1	1	H	H	1		
Open load at high-side switch1	0	0	Z	L	1		
	0	1	Z	H	1		
	1	X	H	X	0		detected
Open load at high-side switch2	0	0	L	Z	1		
	1	0	H	Z	1		
	X	1	X	H	0		detected
Short circuit to DHVS at high-side switch1	0	0	H	L	0	detected	
	0	1	H	H	1		
	1	X	H	X	1		
Short circuit to DHVS at high-side switch2	0	0	L	H	0	detected	
	1	0	H	H	1		
	X	1	X	H	1		
Overtemperature high-side switch1	0	X	L	X	1		
	1	X	L	X	0		detected
Overtemperature high-side switch2	X	0	X	L	1		
	X	1	X	L	0		detected
Overtemperature both high-side switch	0	0	L	L	1		
	X	1	L	L	0		detected
	1	X	L	L	0		detected
Over- and Under-Voltage	X	X	L	L	1	not detected	

Inputs:

0 = Logic LOW

1 = Logic HIGH

X = don't care

Outputs:

Z = Output in tristate condition

L = Output in sink condition

H = Output in source condition

X = Voltage level undefined

Status:

1 = No error

0 = Error

Electrical Characteristics

Absolute Maximum Ratings

$-40\text{ °C} < T_j < 150\text{ °C}$

Parameter	Symbol	Limit Values		Unit	Remarks
		min.	max.		

High-Side-Switches (Pins DHVS, GH1,2 and SH1,2)

Supply voltage	V_S	- 0.3	43	V	-
HS-drain current	I_{DHS}	- 8	*	A	* internally limited
HS-input current	I_{GH}	- 2	2	mA	Pin GH1 and GH2
HS-input voltage	V_{GH}	- 10	16	V	Pin GH1 and GH2

Status Output ST

Status Output current	I_{ST}	- 5	5	mA	Pin ST
-----------------------	----------	-----	---	----	--------

Low-Side-Switches (Pins DL1,2, GL1,2 and SL1,2)

Break-down voltage	$V_{(BR)DSS}$	50	-	V	$V_{GS} = 0\text{ V}; I_D \leq 1\text{ mA}$
LS-drain current	I_{DLS}	-	10	A	-
LS-drain current	I_{DLS}	-	20	A	$t < 1\text{ ms}; v < 0.1$
LS-drain current	I_{DLS}	-	30	A	$t < 0.1\text{ ms}; v < 0.1$
IS-input voltage	V_{GL}	- 10	14	V	Pin GL1 and GL2

Temperatures

Junction temperature	T_j	- 40	150	°C	-
Storage temperature	T_{stg}	- 50	150	°C	-

Thermal Resistances (one HS-LS-Path active)

LS-junction case	R_{thjCLS}	-	20	K/W	measured to pin3 or 12
HS-junction case	R_{thjCHS}	-	20	K/W	measured to pin19
Junction ambient	R_{thja}	-	60	K/W	-

Note: Maximum ratings are absolute ratings; exceeding any one of these values may cause irreversible damage to the integrated circuit.

Operating Range

Parameter	Symbol	Limit Values		Unit	Remarks
		min.	max.		
Supply voltage	V_S	V_{UVOFF}	34	V	After V_S rising above V_{UVON}
Input voltages	V_{GH}	- 0.3	15	V	-
Input voltages	V_{GL}	- 9	13	V	-
Output current	I_{ST}	0	2	mA	-
HS-junction temperature	T_{jHS}	- 40	150	°C	-
LS-junction temperature	T_{jLS}	- 40	150	°C	-

Note: In the operating range the functions given in the circuit description are fulfilled.

Electrical Characteristics

$I_{SH1} = I_{SH2} = I_{SL1} = I_{SL2} = 0 \text{ A}$; $-40 \text{ °C} < T_j < 150 \text{ °C}$; $8 \text{ V} > V_S > 18 \text{ V}$
 unless otherwise specified

Parameter	Symbol	Limit Values			Unit	Test Condition
		min.	typ.	max.		

Current Consumption

Quiescent current	I_S	–	16	30	μA	GH1 = GH2 = L $V_S = 13.2 \text{ V}$ $T_j = 25 \text{ °C}$
Quiescent current	I_S	–	–	35	μA	GH1 = GH2 = L $V_S = 13.2 \text{ V}$
Supply current	I_S	–	2	3.5	mA	GH1 or GH2 = H
Supply current	I_S	–	4	7	mA	GH1 and GH2 = H

Under Voltage Lockout (UVLO)

Switch-ON voltage	V_{UVON}	–	5.4	7	V	V_S increasing
Switch-OFF voltage	V_{UVOFF}	3.5	4.3	–	V	V_S decreasing
Switch ON/OFF hysteresis	V_{UVHY}	–	1.1	–	V	$V_{UVON} - V_{UVOFF}$

Over Voltage Lockout (OVLO)

Switch-OFF voltage	V_{OVOFF}	36	38	43	V	V_S increasing
Switch-ON voltage	V_{OVON}	35	37.3	–	V	V_S decreasing
Switch OFF/ON hysteresis	V_{OVHY}	–	0.7	–	V	$V_{OVOFF} - V_{OVON}$

Short Circuit of Highside Switch to GND

Initial peak SC current	I_{SCP}	8	10	13	A	$T_j = -40 \text{ °C}$
Initial peak SC current	I_{SCP}	6.5	8.5	11	A	$T_j = 25 \text{ °C}$
Initial peak SC current	I_{SCP}	3.9	5	7	A	$T_j = 150 \text{ °C}$

Electrical Characteristics (cont'd)

$I_{SH1} = I_{SH2} = I_{SL1} = I_{SL2} = 0 \text{ A}$; $-40 \text{ }^\circ\text{C} < T_j < 150 \text{ }^\circ\text{C}$; $8 \text{ V} > V_S > 18 \text{ V}$
 unless otherwise specified

Parameter	Symbol	Limit Values			Unit	Test Condition
		min.	typ.	max.		

Short Circuit of Highside Switch to V_S

OFF-state examiner-voltage	V_{EO}	2	3	4	V	$V_{GH} = 0 \text{ V}$
Output pull-down-resistor	R_O	4	11	30	k Ω	–

Open Circuit Detection of Highside Switch

Detection current	I_{OCD}	10	90	200	mA	–
-------------------	-----------	----	----	-----	----	---

Switching Times of Highside Switch

Switch-ON-time; to 90% V_{SH}	t_{ON_H}	–	0.2	0.4	ms	resistive load $I_{SH} = 1 \text{ A}$; $V_S = 12 \text{ V}$
Switch-OFF-time; to 10% V_{SH}	t_{OFF_H}	–	0.15	0.4	ms	resistive load $I_{SH} = 1 \text{ A}$; $V_S = 12 \text{ V}$

Control Inputs of Highside Switches GH 1, 2

H-input voltage	V_{GHH}	–	2.8	3.5	V	–
L-input voltage	V_{GHL}	1.5	2.3	–	V	–
Input voltage hysteresis	V_{GHHY}	–	0.5	–	V	–
H-input current	I_{GHH}	20	60	90	μA	$V_{GH} = 5 \text{ V}$
L-input current	I_{GHL}	1	25	50	μA	$V_{GH} = 0.4 \text{ V}$
Input series resistance	R_I	2.5	3.5	6	k Ω	–
Zener limit voltage	V_{GHZ}	5.4	–	–	V	$I_{GH} = 1.6 \text{ mA}$

Status Flag Output ST of Highside Switch

Low output voltage	V_{STL}	–	0.25	0.6	V	$I_{ST} = 1.6 \text{ mA}$
Leakage current	I_{STLK}	–	0.5	10	μA	$V_{ST} = 5 \text{ V}$
Zener-limit-voltage	V_{STZ}	5.4	–	–	V	$I_{ST} = 1.6 \text{ mA}$

Electrical Characteristics (cont'd)

$I_{SH1} = I_{SH2} = I_{SL1} = I_{SL2} = 0 \text{ A}$; $-40 \text{ °C} < T_j < 150 \text{ °C}$; $8 \text{ V} > V_S > 18 \text{ V}$
 unless otherwise specified

Parameter	Symbol	Limit Values			Unit	Test Condition
		min.	typ.	max.		

Control Inputs of Lowside Switches GL1, 2

Gate-threshold-voltage	$V_{GL(th)}$	0.8	1.6	2.5	V	$V_{GL} = V_{DSL}$; $I_{DL} = 1 \text{ mA}$
Transconductance	g_{fs}	–	5	–	S	$V_{DSL} = 20 \text{ V}$; $I_{DL} = 20 \text{ A}$

Switching Times of Lowside Switch

Switch-ON delay time; $V_{GS} = 5 \text{ V}$; $R_{GS} = 50\Omega$	$t_{d_ON_L}$	–	25	40	ns	resistive load $I_{SL} = 1 \text{ A}$; $V_S = 12 \text{ V}$
Switch-ON time; $V_{GS} = 5 \text{ V}$; $R_{GS} = 50\Omega$	t_{ON_L}	–	95	140	ns	resistive load $I_{SL} = 1 \text{ A}$; $V_S = 12 \text{ V}$
Switch-OFF delay time; $V_{GS} = 5 \text{ V}$; $R_{GS} = 50\Omega$	$t_{d_OFF_L}$	–	140	190	ns	resistive load $I_{SL} = 1 \text{ A}$; $V_S = 12 \text{ V}$
Switch-OFF time; $V_{GS} = 5 \text{ V}$; $R_{GS} = 50\Omega$	t_{OFF_L}	–	85	115	ns	resistive load $I_{SL} = 1 \text{ A}$; $V_S = 12 \text{ V}$

Thermal Shutdown

Thermal shutdown junction temperature	T_{jSD}	155	–	190	°C	–
Thermal switch-on junction temperature	T_{jSO}	150	–	180	°C	–
Temperature hysteresis	ΔT	–	10	–	°C	$\Delta T = T_{jSD} - T_{jSO}$

Electrical Characteristics (cont'd)

$I_{SH1} = I_{SH2} = I_{SL1} = I_{SL2} = 0 \text{ A}$; $-40 \text{ }^\circ\text{C} < T_j < 150 \text{ }^\circ\text{C}$; $8 \text{ V} > V_S > 18 \text{ V}$
 unless otherwise specified

Parameter	Symbol	Limit Values			Unit	Test Condition
		min.	typ.	max.		

Output Stages

Leakage current of highside switch	I_{HSLK}	–	5	12	μA	$V_{GH} = V_{SH} = 0 \text{ V}$
Leakage current of lowside switch	I_{LSLK}	–	20	100	μA	$V_{GL} = 0 \text{ V}$ $V_{DS} = 18 \text{ V}$
Clamp-diode of highside switch; Forward-Voltage	V_{FH}	–	0.8	1.5	V	$I_{FH} = 3 \text{ A}$
Clamp-diode leakage-current ($I_{FH} + I_{SH}$) of highside switch	I_{LKCL}	–	2	10	mA	$I_{FH} = 3 \text{ A}$
Clamp-diode of lowside switch; forward-voltage	V_{FL}	–	0.8	1.5	V	$I_{FL} = 3 \text{ A}$
Static drain-source on-resistance of highside switch	$R_{DS\ ON\ H}$	–	165	220	m Ω	$I_{SH} = 1 \text{ A}$ $T_j = 25 \text{ }^\circ\text{C}$
Static drain-source on-resistance of lowside switch	$R_{DS\ ON\ L}$	–	45	65	m Ω	$I_{SL} = 1 \text{ A}$; $V_{GL} = 5 \text{ V}$ $T_j = 25 \text{ }^\circ\text{C}$
Static path on-resistance	$R_{DS\ ON}$	–	–	500	m Ω	$R_{DS\ ON\ H} + R_{DS\ ON\ L}$; $I_{SH} = 1 \text{ A}$

Note: The listed characteristics are ensured over the operating range of the integrated circuit. Typical characteristics specify mean values expected over the production spread. If not otherwise specified, typical characteristics apply at $T_A = 25^\circ\text{C}$ and the given supply voltage.

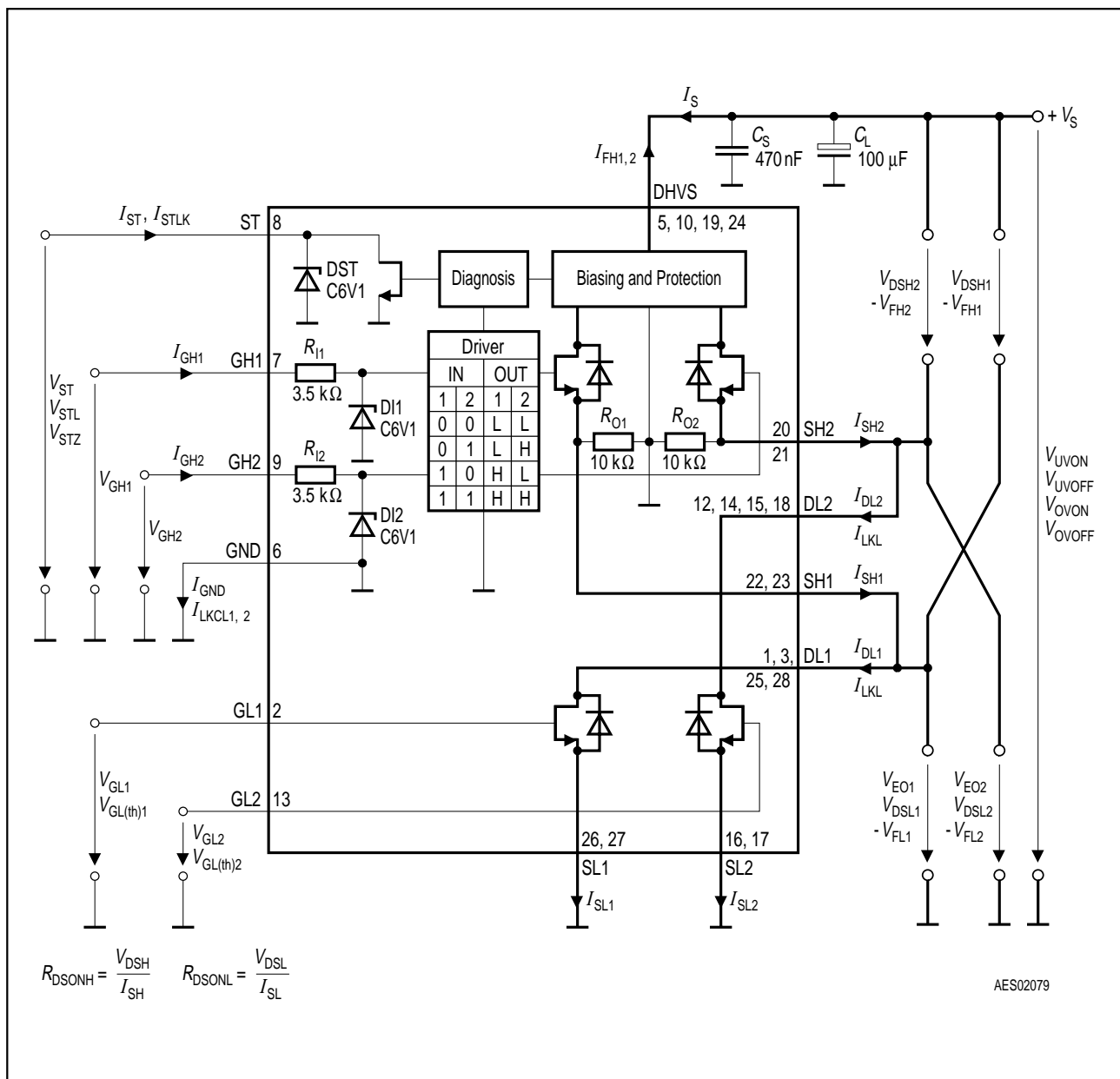
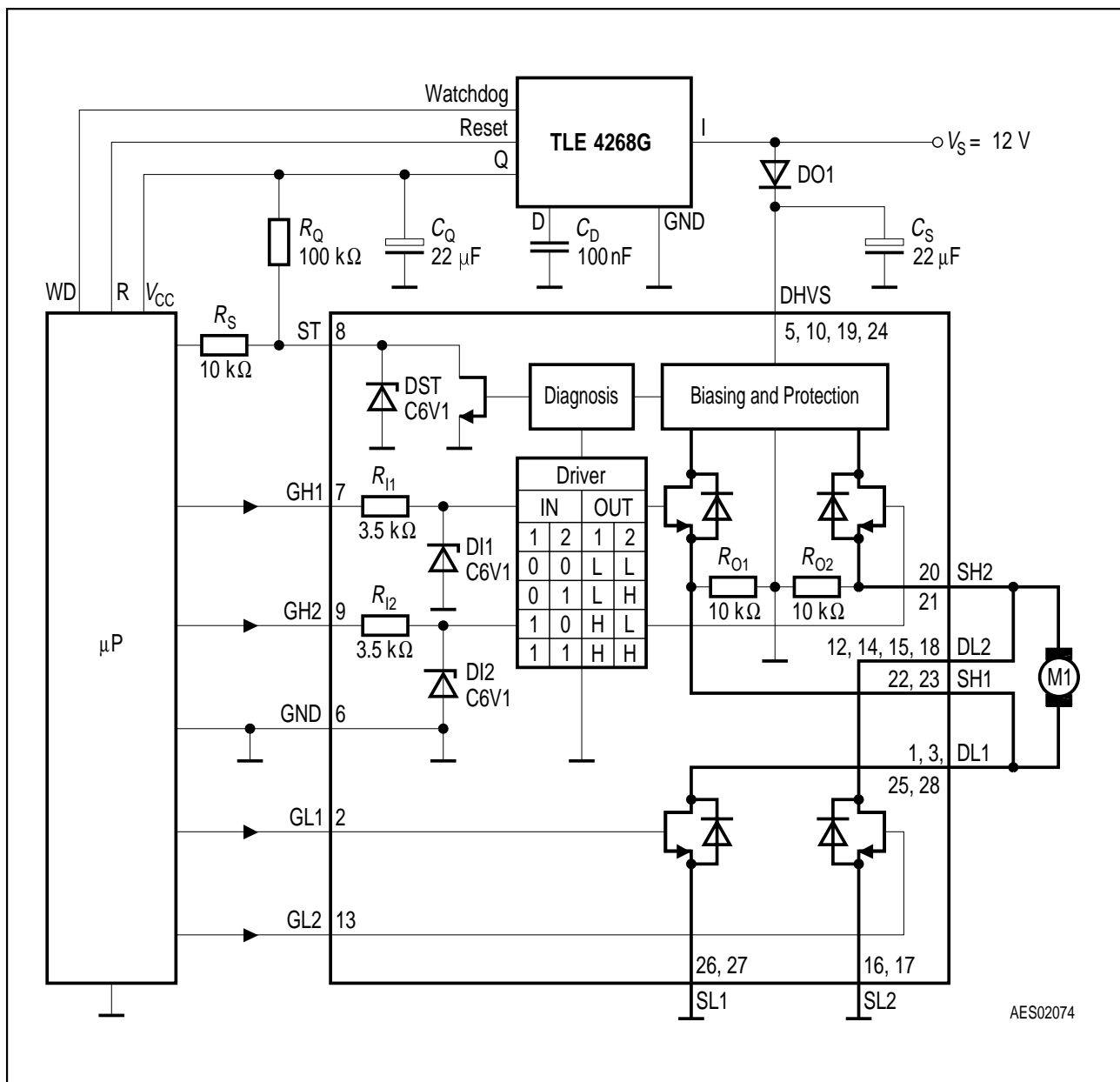

Figure 3 Test Circuit

HS-Source-Current	Named during Short Circuit	Named during Open Circuit	Named during Leakage-Cond.
$I_{SH1,2}$	I_{SCP}	I_{OCD}	I_{HSLK}



AES02074

Figure 4 Application Circuit

Package Outlines

P-DSO-28-9
(Plastic Dual Small Outline Package)

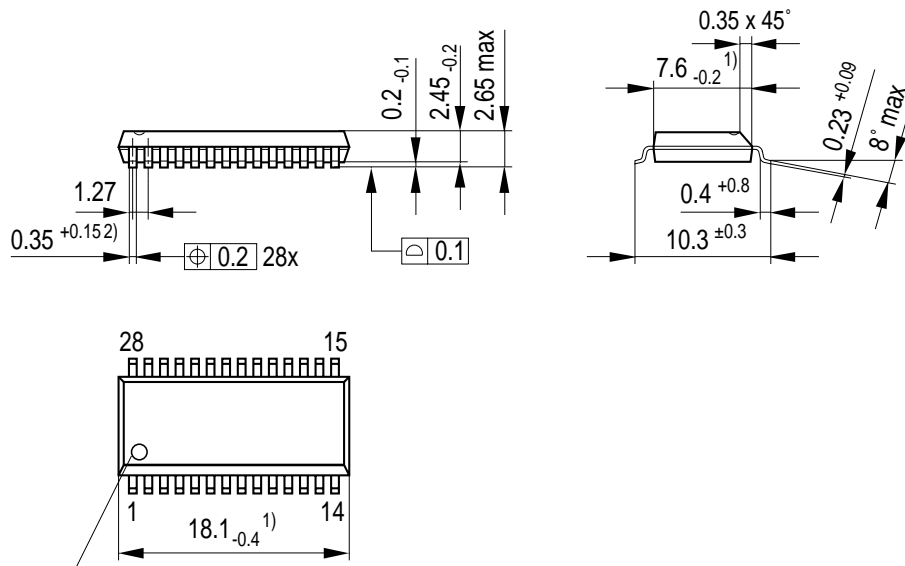

Index Marking

- 1) Does not include plastic or metal protrusions of 0.15 max per side
- 2) Does not include dambar protrusion of 0.05 max per side

GPS05123

Sorts of Packing

Package outlines for tubes, trays etc. are contained in our Data Book "Package Information".

SMD = Surface Mounted Device

Dimensions in mm



LittleDiode supplies new, hard to find or obsolete electronic components and semiconductors all over the world.

With over two million different components listed you are sure to find the part you need.

Feel free to visit us today at our online store:

LittleDiode.com

Looking forward to providing you with the best possible service.