

HMC270MS8G

GaAs MMIC SPDT SWITCH NON-REFLECTIVE, DC - 8.0 GHz

Typical Applications

The HMC270MS8G is ideal for DC - 8.0 GHz applications:

- CATV
- MMDS & WirelessLAN
- Wireless Local Loop

Functional Diagram

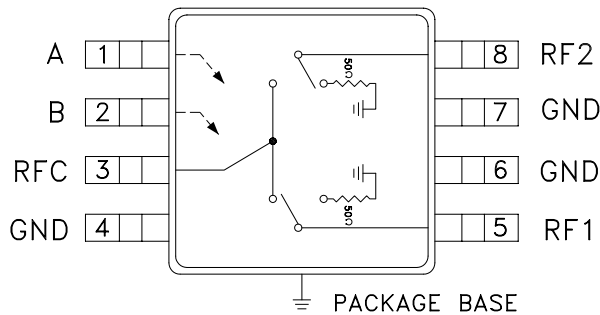

Features

- Broadband Performance: DC - 8 GHz
- Very High Isolation: 45 dB @ 6 GHz
- Non-Reflective Design
- Low Cost MSOP-8 Package: 14.8 mm²

General Description

The HMC270MS8G is a broadband non-reflective GaAs SPDT switch in an 8 lead MSOP grounded base surface mount plastic package. Covering DC to 8 GHz, the switch offers excellent isolation from 70 to 35 dB. The negative control voltage of -5 volts allows operation down to DC. If positive control is required along with high isolation, see the DC to 3.5 GHz HMC284MS8G non-reflective SPDT.

Electrical Specifications, $T_A = +25^\circ\text{C}$, With 0/-5V Control, 50 Ohm system

Parameter	Frequency	Min.	Typ.	Max.	Units
Insertion Loss	DC - 2.0 GHz		0.8	1.2	dB
	DC - 6.0 GHz		1.0	1.7	dB
	DC - 8.0 GHz		1.5	2.4	dB
Isolation	DC - 2.0 GHz	43	48		dB
	DC - 4.0 GHz	42	47		dB
	DC - 6.0 GHz	37	45		dB
	DC - 8.0 GHz	28	33		dB
Return Loss	"On State"	DC - 2.0 GHz	11	14	dB
		DC - 6.0 GHz	9	12	dB
		DC - 8.0 GHz	7	10	dB
Return Loss RF1, RF2	"Off State"	DC - 2.0 GHz	15	20	dB
		DC - 6.0 GHz	13	18	dB
		DC - 8.0 GHz	10	15	dB
Input Power for 1 dB Compression	0.5 - 8.0 GHz	20	23		dBm
Input third Order Intercept (Two-Tone Input Power = +7 dBm Each Tone)	0.5 - 8.0 GHz	33	36		dBm
Switching Characteristics	DC - 8.0 GHz				
		tRISE, tFALL (10/90% RF)		20	ns
		tON, tOFF (50% CTL to 10/90% RF)		50	ns

GaAs MMIC SPDT SWITCH NON-REFLECTIVE, DC - 8.0 GHz

Insertion Loss

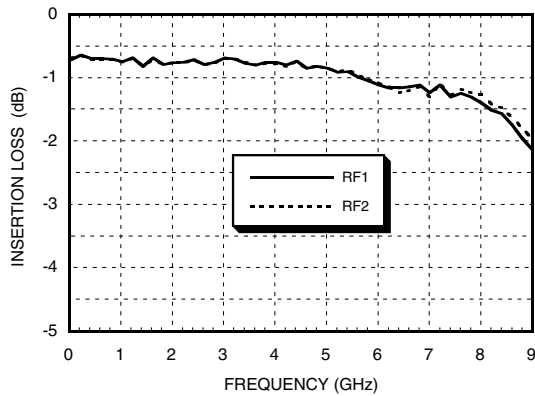

Isolation

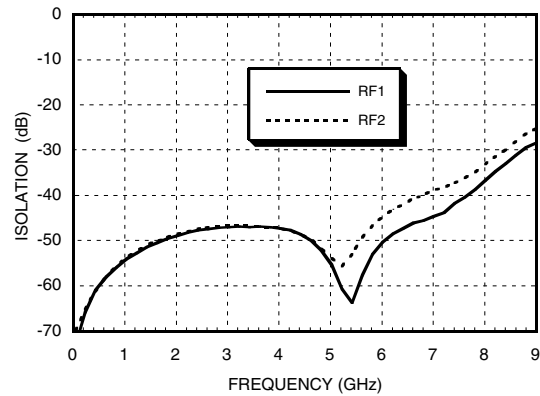

Return Loss

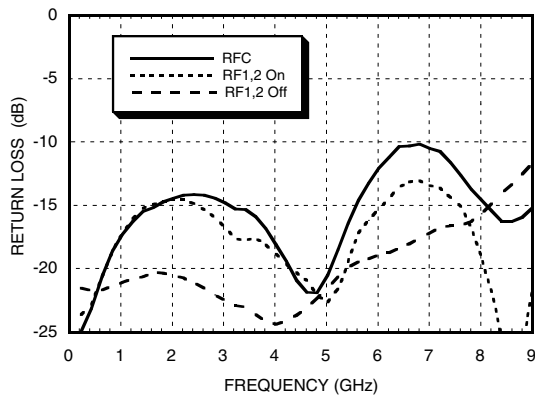

0.1 and 1 dB Input Compression Point

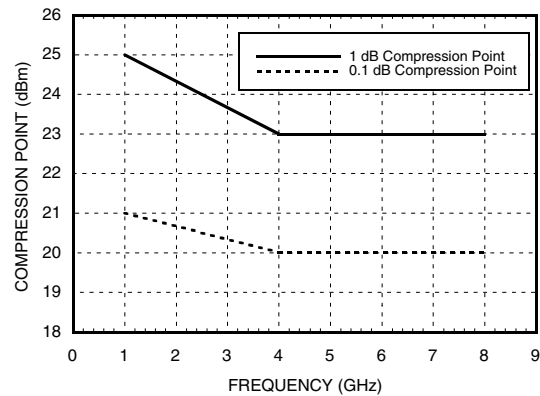

Input Third Order Intercept Point

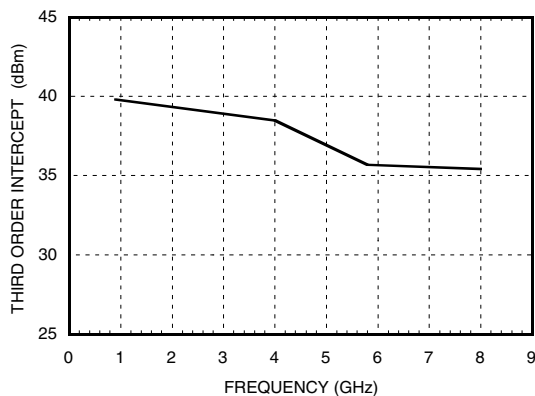

Control Voltages

State	Bias Condition
Low	0 to -0.2V @ 10 uA Typ.
High	-5V @ 35 uA Typ. to -7V @ 100 uA Typ (±0.5 Vdc)

RFC, RF1, & RF2 should be at <100 mV DC potential. Otherwise, DC blocking capacitors are recommended. Choose value for lowest frequency of operation.

Do not "HOT" switch power levels >+13 dBm (Vctl = 0/-5Vdc)

Truth Table

Control Input		Signal Path State	
A	B	RFC to RF1	RFC to RF2
High	Low	ON	OFF
Low	High	OFF	ON

GaAs MMIC SPDT SWITCH NON-REFLECTIVE, DC - 8.0 GHz

Absolute Maximum Ratings

Max RF Input Power, Vctl = -5V	+24 dBm
Control Voltage Range	+0.5 to -7.5 Vdc
Storage Temperature	-65 to +150 °C
Operating Temperature	-40 to +85 °C

Outline Drawing

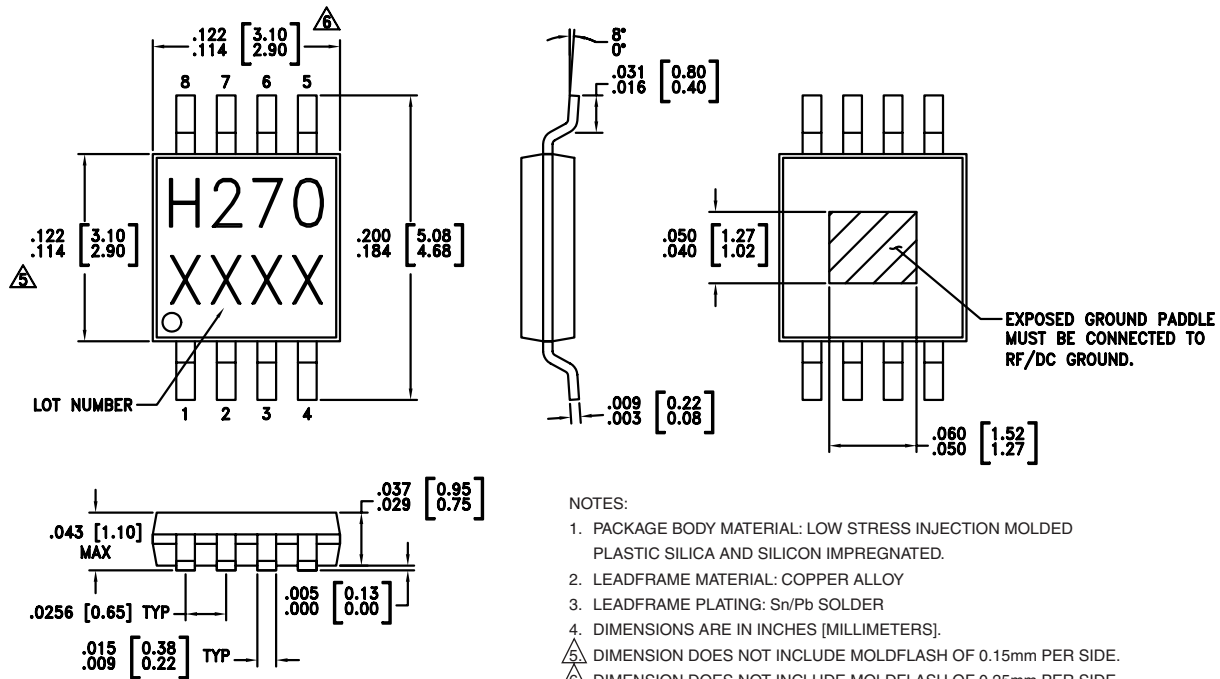

Suggested Driver Circuit for HMC270MS8G

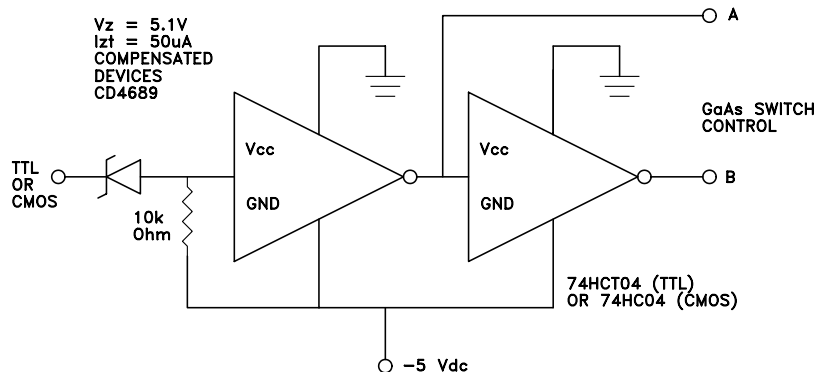

Simple driver using inexpensive standard logic ICs provides fast switching using minimum DC current while translating from standard positive voltage TTL or CMOS logic to negative voltage GaAs IC logic.

For price, delivery, and to place orders, please contact Hittite Microwave Corporation:
12 Elizabeth Drive, Chelmsford, MA 01824 Phone: 978-250-3343 Fax: 978-250-3373
Order Online at www.hittite.com

GaAs MMIC SPDT SWITCH NON-REFLECTIVE, DC - 8.0 GHz

Eval Board Layout (Top View)

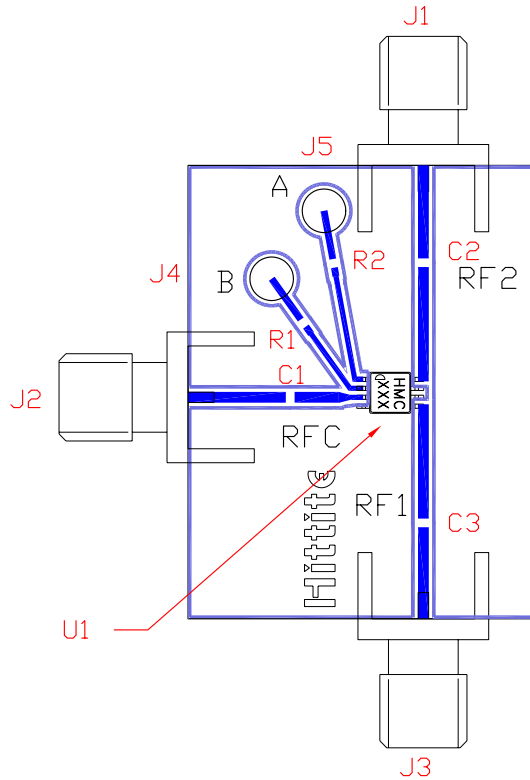

*R1 = R2 = 100 Ohm.
These are optional resistors.

List of Materials

Item	Description
J1 - J3	PC Mount SMA Connector
J4 - J5	DC Pin
C1 - C3	Chip Capacitor, 0402 Pkg, choose value for lowest frequency of operation. PCBs are provided with 100 ~ 300 pF capacitors. User may jumper capacitor mounting gaps on PCB to allow operation to "DC".
R1 - R2	100 Ohm Resistor, 0402 Pkg.
U1	HMC270MS8G SPDT Switch
PCB*	102807 Evaluation PCB 2.0" x 2.6"
* Circuit Board Material: Rogers 4350	

The circuit board used in the final application should be generated with proper RF circuit design techniques. Signal lines at the RF ports should have 50 ohm impedance and the package ground leads and exposed ground paddle should be connected directly to the ground plane similar to that shown above. The evaluation circuit board shown above is available from Hittite Microwave Corporation upon request.



LittleDiode supplies new, hard to find or obsolete electronic components and semiconductors all over the world.

With over two million different components listed you are sure to find the part you need.

Feel free to visit us today at our online store:

LittleDiode.com

Looking forward to providing you with the best possible service.