

# BLF881; BLF881S

UHF power LDMOS transistor

Rev. 3 — 7 December 2010

Product data sheet

## 1. Product profile

### 1.1 General description

A 140 W LDMOS RF power transistor for broadcast transmitter applications and industrial applications. The transistor can deliver 140 W from HF to 1 GHz. The excellent ruggedness and broadband performance of this device makes it ideal for digital transmitter applications.

**Table 1. Typical performance**

RF performance at  $V_{DS} = 50$  V in a common-source 860 MHz test circuit.

Mode of operation	f (MHz)	$P_L$ (W)	$P_{L(PEP)}$ (W)	$P_{L(AV)}$ (W)	$G_p$ (dB)	$\eta_D$ (%)	IMD3 (dBc)	IMD <sub>shldr</sub> (dBc)
2-tone, class AB	$f_1 = 860$ ; $f_2 = 860.1$	-	140	-	21	49	-34	-
DVB-T (8k OFDM)	858	-	-	33	21	34	-	-33 <sup>[1]</sup>

[1] Measured [dBc] with delta marker at 4.3 MHz from center frequency.

#### CAUTION



This device is sensitive to ElectroStatic Discharge (ESD). Therefore care should be taken during transport and handling.

### 1.2 Features and benefits

- 2-Tone performance at 860 MHz, a drain-source voltage  $V_{DS}$  of 50 V and a quiescent drain current  $I_{Dq} = 0.5$  A:
  - ◆ Peak envelope power load power = 140 W
  - ◆ Power gain = 21 dB
  - ◆ Drain efficiency = 49 %
  - ◆ Third order intermodulation distortion = -34 dBc
- DVB performance at 858 MHz, a drain-source voltage  $V_{DS}$  of 50 V and a quiescent drain current  $I_{Dq} = 0.5$  A:
  - ◆ Average output power = 33 W
  - ◆ Power gain = 21 dB
  - ◆ Drain efficiency = 34 %
  - ◆ Shoulder distance = -33 dBc (4.3 MHz from center frequency)
- Integrated ESD protection
- Excellent ruggedness
- High power gain



- High efficiency
- Excellent reliability
- Easy power control
- Compliant to Directive 2002/95/EC, regarding Restriction of Hazardous Substances (RoHS)

### 1.3 Applications

- Communication transmitter applications in the UHF band
- Industrial applications in the UHF band

## 2. Pinning information

**Table 2. Pinning**

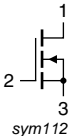
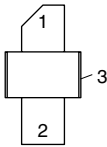
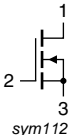
Pin	Description	Simplified outline	Graphic symbol
<b>BLF881 (SOT467C)</b>			
1	drain		 sym112
2	gate		
3	source <a href="#">[1]</a>		
<b>BLF881S (SOT467B)</b>			
1	drain		 sym112
2	gate		
3	source <a href="#">[1]</a>		

[1] Connected to flange.

## 3. Ordering information

**Table 3. Ordering information**

Type number	Package		
	Name	Description	Version
BLF881	-	flanged LDMOST ceramic package; 2 mounting holes; 2 leads	SOT467C
BLF881S	-	earless LDMOST ceramic package; 2 leads	SOT467B

## 4. Limiting values

**Table 4. Limiting values**

In accordance with the Absolute Maximum Rating System (IEC 60134).

Symbol	Parameter	Conditions	Min	Max	Unit
$V_{DS}$	drain-source voltage		-	104	V
$V_{GS}$	gate-source voltage		-0.5	+13	V
$T_{stg}$	storage temperature		-65	+150	°C
$T_j$	junction temperature		-	200	°C

## 5. Thermal characteristics

**Table 5. Thermal characteristics**

Symbol	Parameter	Conditions	Typ	Unit
$R_{th(j-c)}$	thermal resistance from junction to case	$T_{case} = 80\text{ °C}$ ; $P_{L(AV)} = 70\text{ W}$	[1]	0.95 K/W

[1]  $R_{th(j-c)}$  is measured under RF conditions.

## 6. Characteristics

**Table 6. DC characteristics**

$T_j = 25\text{ °C}$  unless otherwise specified.

Symbol	Parameter	Conditions	Min	Typ	Max	Unit
$V_{(BR)DSS}$	drain-source breakdown voltage	$V_{GS} = 0\text{ V}$ ; $I_D = 1.35\text{ mA}$	[1]	104	-	V
$V_{GS(th)}$	gate-source threshold voltage	$V_{DS} = 10\text{ V}$ ; $I_D = 135\text{ mA}$	[1]	1.4	2.4	V
$I_{DSS}$	drain leakage current	$V_{GS} = 0\text{ V}$ ; $V_{DS} = 50\text{ V}$	-	-	1.4	$\mu\text{A}$
$I_{DSX}$	drain cut-off current	$V_{GS} = V_{GSth} + 3.75\text{ V}$ ; $V_{DS} = 10\text{ V}$	19	21	-	A
$I_{GSS}$	gate leakage current	$V_{GS} = 10\text{ V}$ ; $V_{DS} = 0\text{ V}$	-	-	140	nA
$R_{DS(on)}$	drain-source on-state resistance	$V_{GS} = V_{GSth} + 3.75\text{ V}$ ; $I_D = 4.5\text{ A}$	[1]	-	210	$\text{m}\Omega$
$C_{iss}$	input capacitance	$V_{GS} = 0\text{ V}$ ; $V_{DS} = 50\text{ V}$ ; $f = 1\text{ MHz}$	-	100	-	pF
$C_{oss}$	output capacitance	$V_{GS} = 0\text{ V}$ ; $V_{DS} = 50\text{ V}$ ; $f = 1\text{ MHz}$	-	33.5	-	pF
$C_{rss}$	reverse transfer capacitance	$V_{GS} = 0\text{ V}$ ; $V_{DS} = 50\text{ V}$ ; $f = 1\text{ MHz}$	-	1	-	pF

[1]  $I_D$  is the drain current.

**Table 7. RF characteristics**

$T_h = 25\text{ °C}$  unless otherwise specified.

Symbol	Parameter	Conditions	Min	Typ	Max	Unit
<b>2-Tone, class AB</b>						
$V_{DS}$	drain-source voltage		-	50	-	V
$I_{Dq}$	quiescent drain current		-	0.5	-	A
$P_{L(PEP)}$	peak envelope power load power		-	140	-	W
$G_p$	power gain		20	21	-	dB
$\eta_D$	drain efficiency		45	49	-	%
IMD3	third-order intermodulation distortion		-	-34	-30	dBc

**Table 7. RF characteristics ...continued**  
 $T_h = 25\text{ }^\circ\text{C}$  unless otherwise specified.

Symbol	Parameter	Conditions	Min	Typ	Max	Unit
<b>DVB-T (8k OFDM)</b>						
$V_{DS}$	drain-source voltage		-	50	-	V
$I_{Dq}$	quiescent drain current		-	0.5	-	A
$P_{L(AV)}$	average output power		-	33	-	W
$G_p$	power gain		20	21	-	dB
$\eta_D$	drain efficiency		30	34	-	%
$IMD_{shldr}$	intermodulation distortion shoulder		[1]	-33	-30	dBc
PAR	peak-to-average ratio		[2]	8.3	-	dB

[1] Measured [dBc] with delta marker at 4.3 MHz from center frequency.

[2] PAR (of output signal) at 0.01 % probability on CCDF; PAR of input signal = 9.5 dB at 0.01 % probability on CCDF.

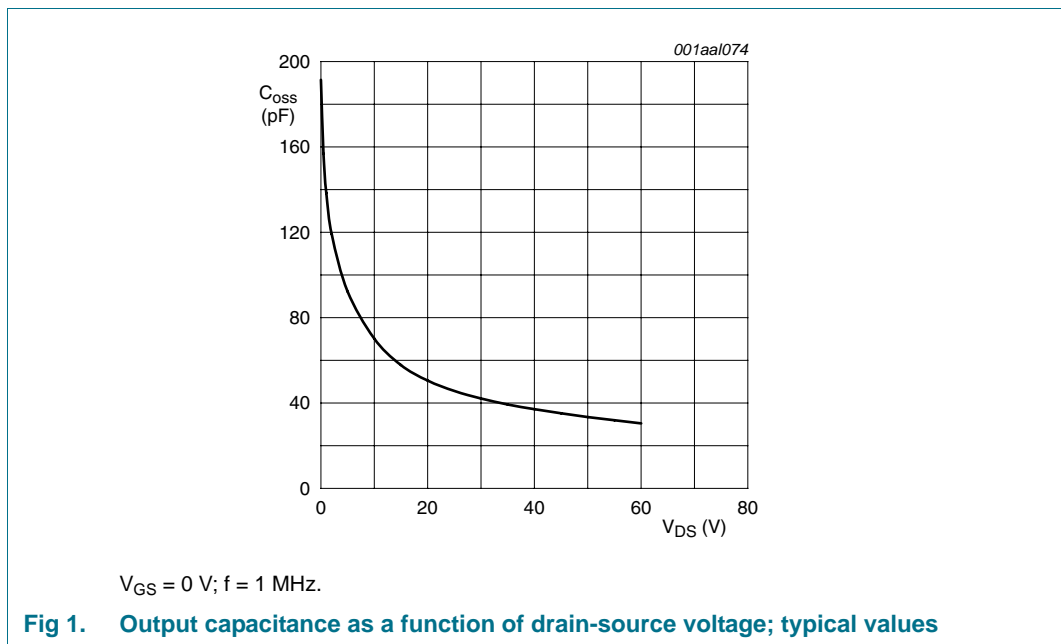

**7. Application information**

**7.1 Narrowband RF figures**

**7.1.1 CW**

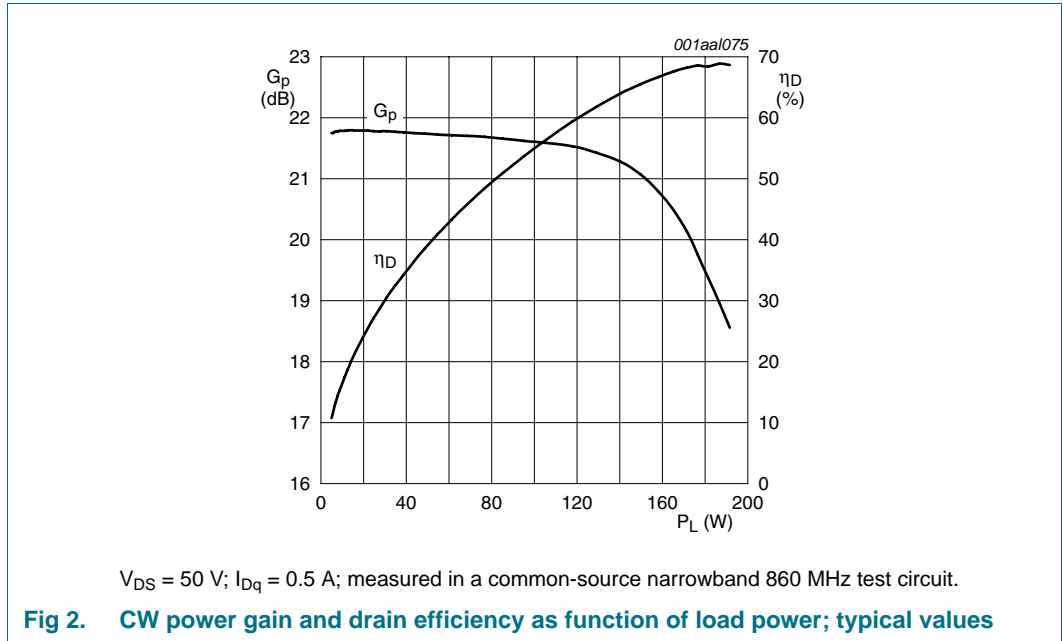

**7.1.2 2-Tone**

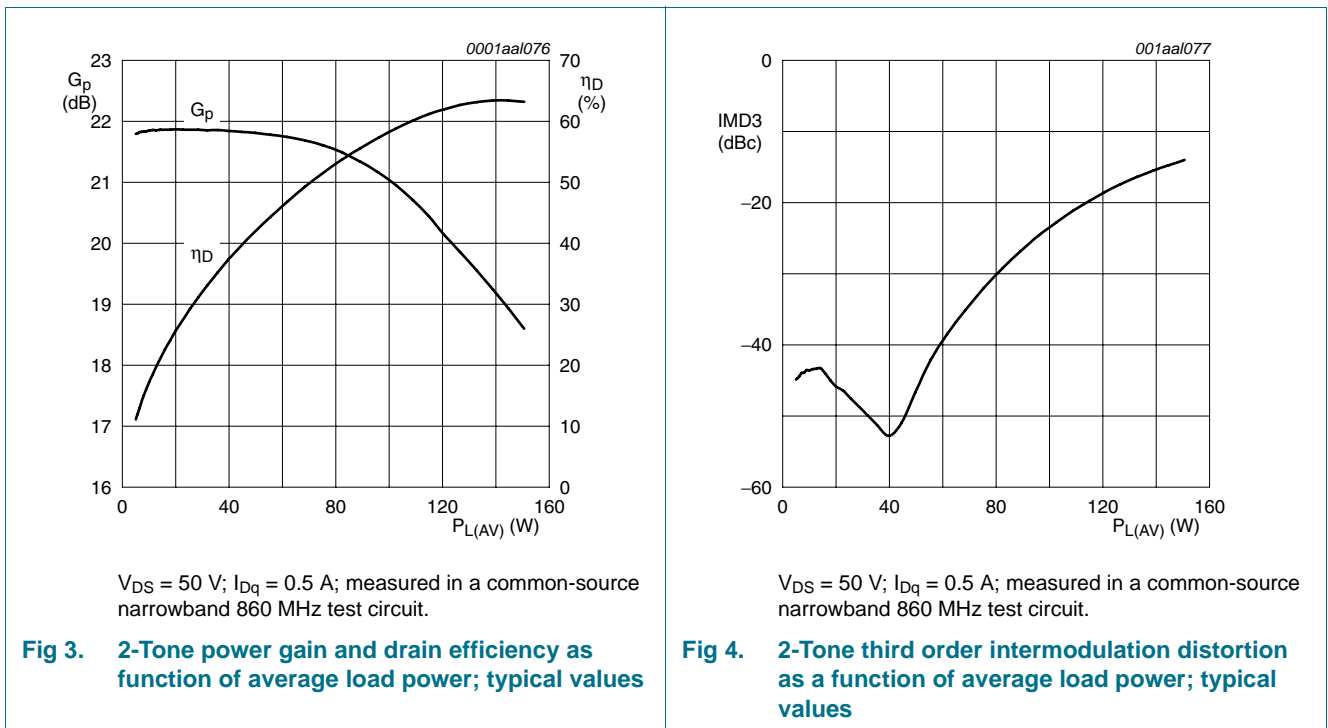

**7.1.3 DVB-T**

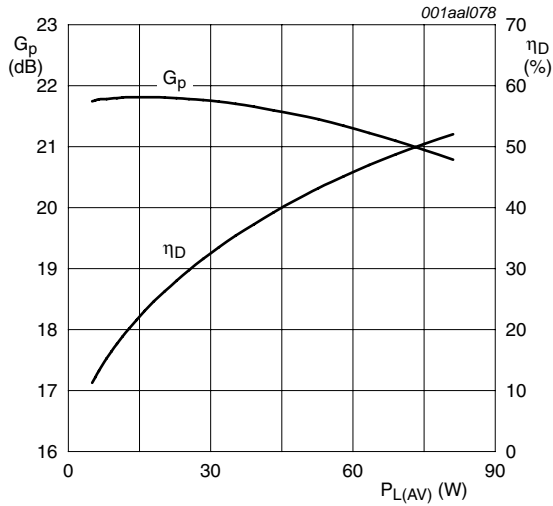

$V_{DS} = 50\text{ V}$ ;  $I_{Dq} = 0.5\text{ A}$ ; measured in a common-source narrowband 860 MHz test circuit.

**Fig 5. DVB-T power gain and drain efficiency as function of average load power; typical values**

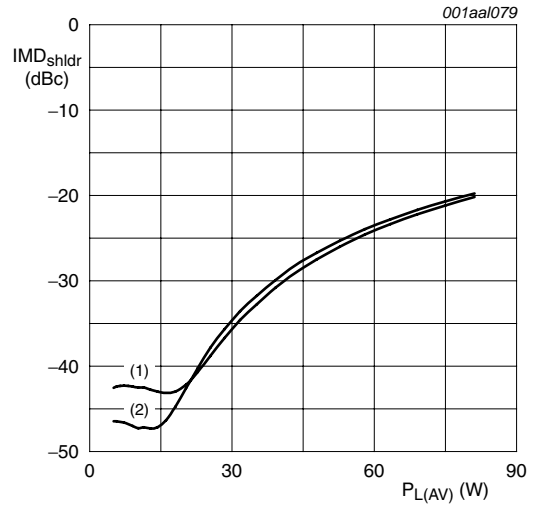

$V_{DS} = 50\text{ V}$ ;  $I_{Dq} = 0.5\text{ A}$ ; measured in a common-source narrowband 860 MHz test circuit.

- (1) Lower adjacent channel
- (2) Upper adjacent channel

**Fig 6. DVB-T shoulder distance as a function of average load power; typical values**

**7.2 Broadband RF figures**

**7.2.1 DVB-T**

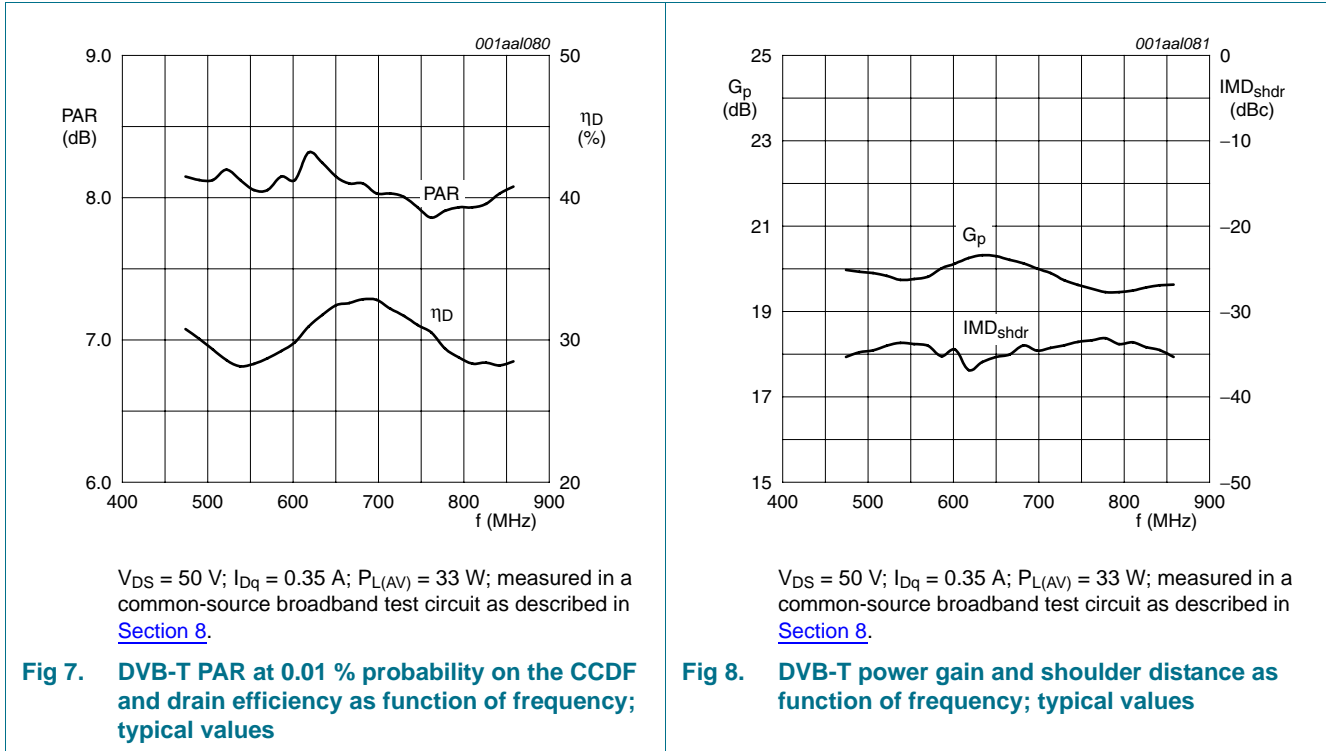

**7.3 Ruggedness in class-AB operation**

The BLF881 and BLF881S are capable of withstanding a load mismatch corresponding to  $V_{SWR} = 10 : 1$  through all phases under the following conditions:  $V_{DS} = 50 V$ ;  $f = 860 MHz$  at rated power. Ruggedness is measured in the application circuit as described in [Section 8](#).

**7.4 Reliability**

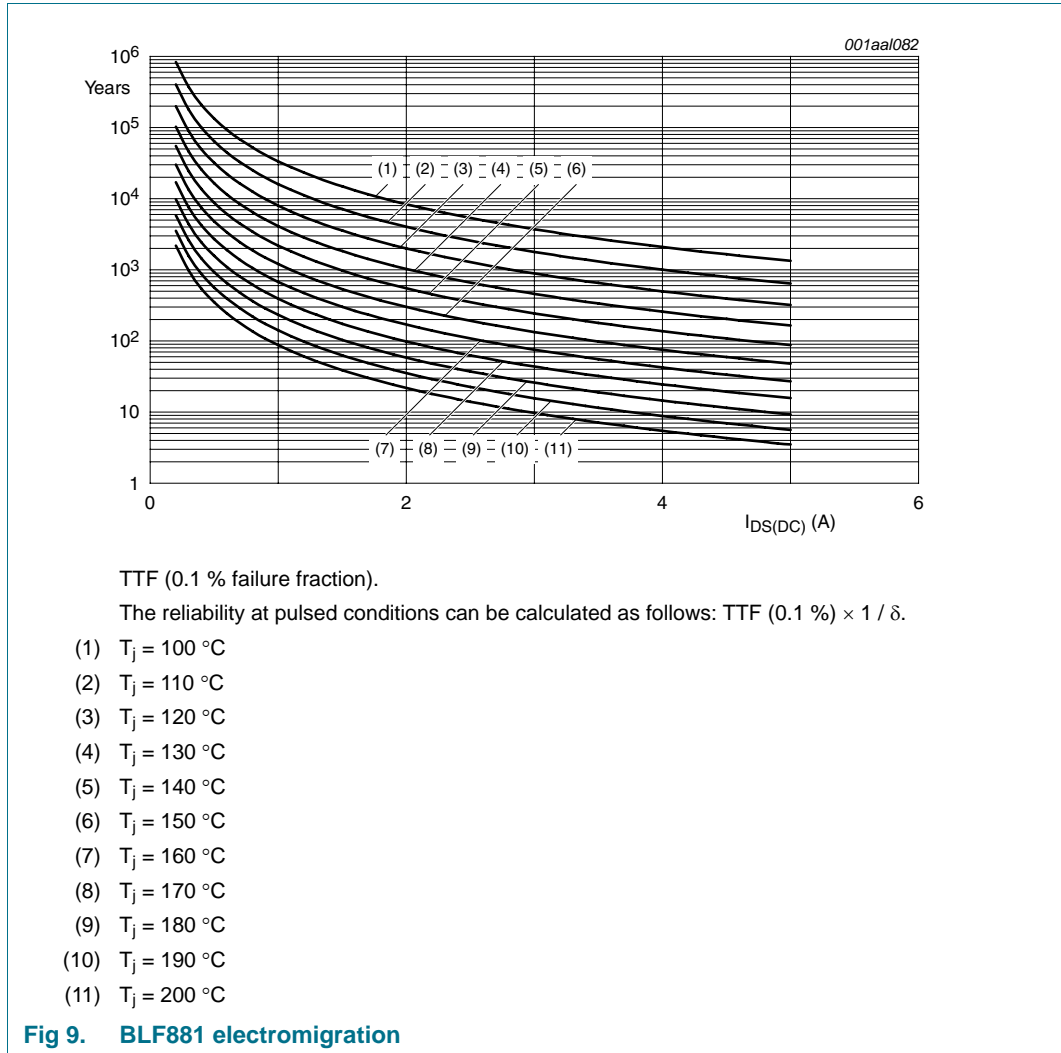

## 8. Test information

**Table 8. List of components**

For test circuit, see [Figure 10](#), [Figure 11](#) and [Figure 12](#).

Component	Description	Value	Remarks
C1, C2	multilayer ceramic chip capacitor	5.1 pF	[1]
C3, C4	multilayer ceramic chip capacitor	10 pF	[2]
C5	multilayer ceramic chip capacitor	6.8 pF	[1]
C6	multilayer ceramic chip capacitor	4.7 pF	[1]
C7	multilayer ceramic chip capacitor	2.7 pF	[1]
C8, C9, C10, C25, C26	multilayer ceramic chip capacitor	100 pF	[1]
C11, C27	multilayer ceramic chip capacitor	10 $\mu$ F	TDK C570X7R1H106KT000N or capacitor of same quality.
C12	electrolytic capacitor	470 $\mu$ F; 63 V	
C20	multilayer ceramic chip capacitor	10 pF	[3]
C21	multilayer ceramic chip capacitor	8.2 pF	[3]
C22	trimmer	0.6 pF to 4.5 pF	Tekelec
C23	multilayer ceramic chip capacitor	6.8 pF	[3]
C24	multilayer ceramic chip capacitor	3.9 pF	[3]
L1	stripline	-	[4] (W $\times$ L) 7 mm $\times$ 15 mm
L2	stripline	-	[4] (W $\times$ L) 2.4 mm $\times$ 9 mm
L3	stripline	-	[4] (W $\times$ L) 2.4 mm $\times$ 10 mm
L4	stripline	-	[4] (W $\times$ L) 2.4 mm $\times$ 25 mm
L5	stripline	-	[4] (W $\times$ L) 2.4 mm $\times$ 10 mm
L6	stripline	-	[4] (W $\times$ L) 2.0 mm $\times$ 20 mm
L7	stripline	-	[4] (W $\times$ L) 2.0 mm $\times$ 21 mm
L20	stripline	-	[4] (W $\times$ L) 7 mm $\times$ 12 mm
L21	stripline	-	[4] (W $\times$ L) 2.4 mm $\times$ 13 mm
L22	stripline	-	[4] (W $\times$ L) 2.4 mm $\times$ 31 mm
L23	stripline	-	[4] (W $\times$ L) 2.4 mm $\times$ 5 mm
R1	resistor	100 $\Omega$	
R2	resistor	10 k $\Omega$	

[1] American technical ceramics type 100B or capacitor of same quality.

[2] American technical ceramics type 180R or capacitor of same quality.

[3] American technical ceramics type 100A or capacitor of same quality.

[4] Printed-Circuit Board (PCB): Rogers 5880;  $\epsilon_r = 2.2$  F/m; height = 0.79 mm; Cu (top/bottom metallization); thickness copper plating = 35  $\mu$ m.

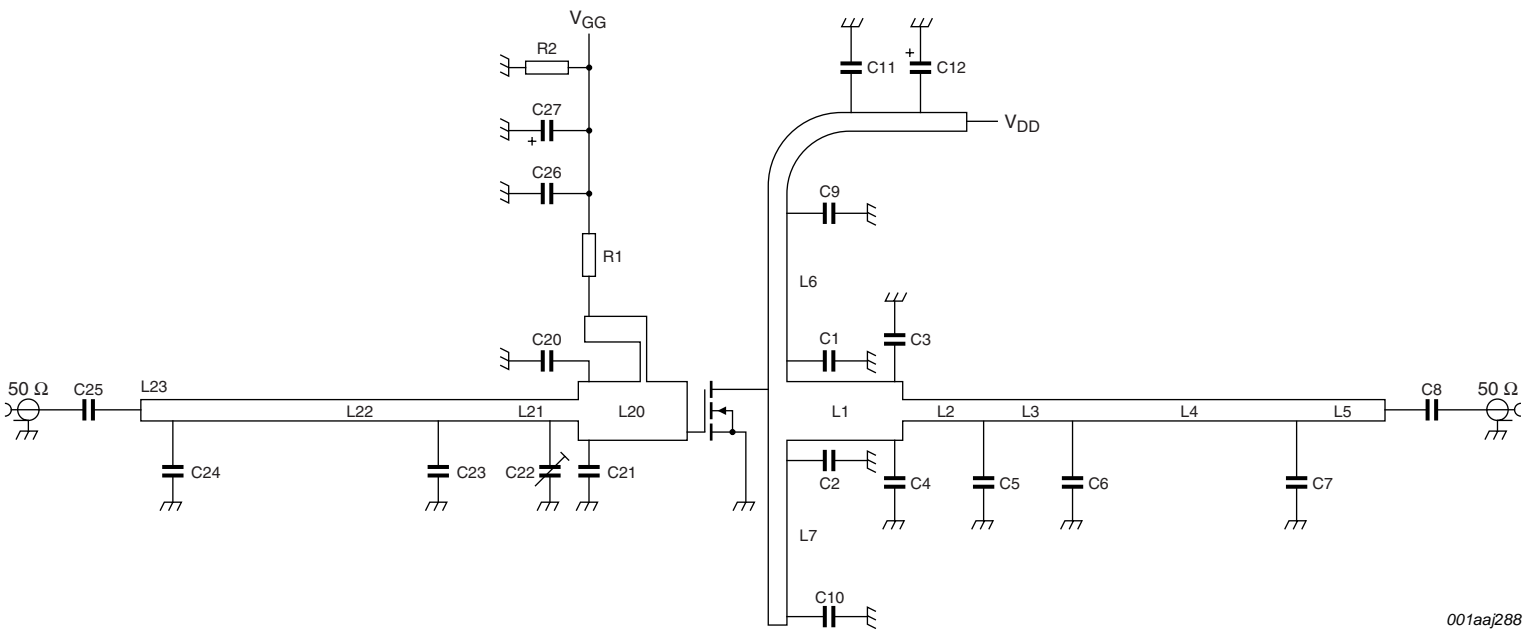

001aa|288

See [Table 8](#) for a list of components.

**Fig 10. Class-AB common-source broadband amplifier**

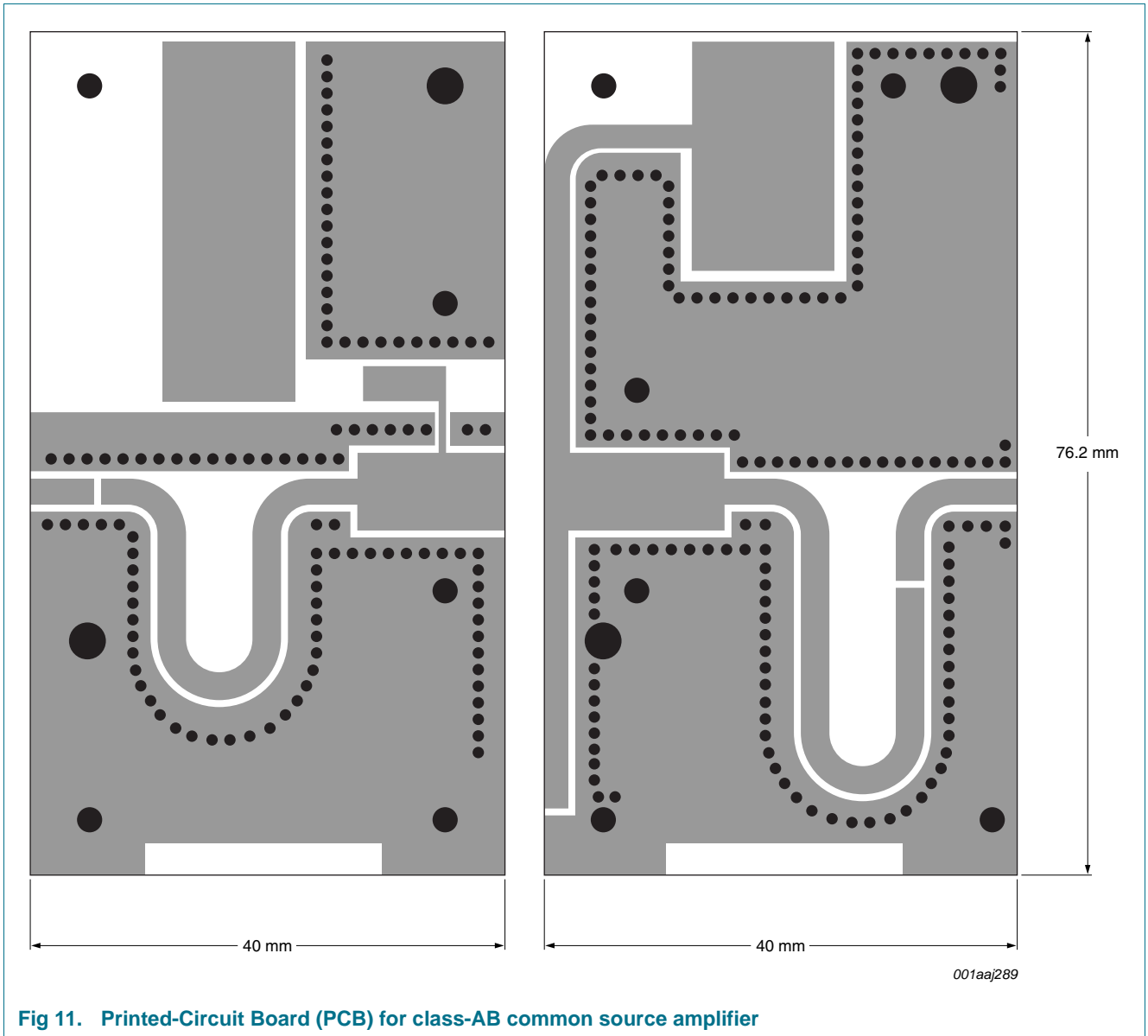

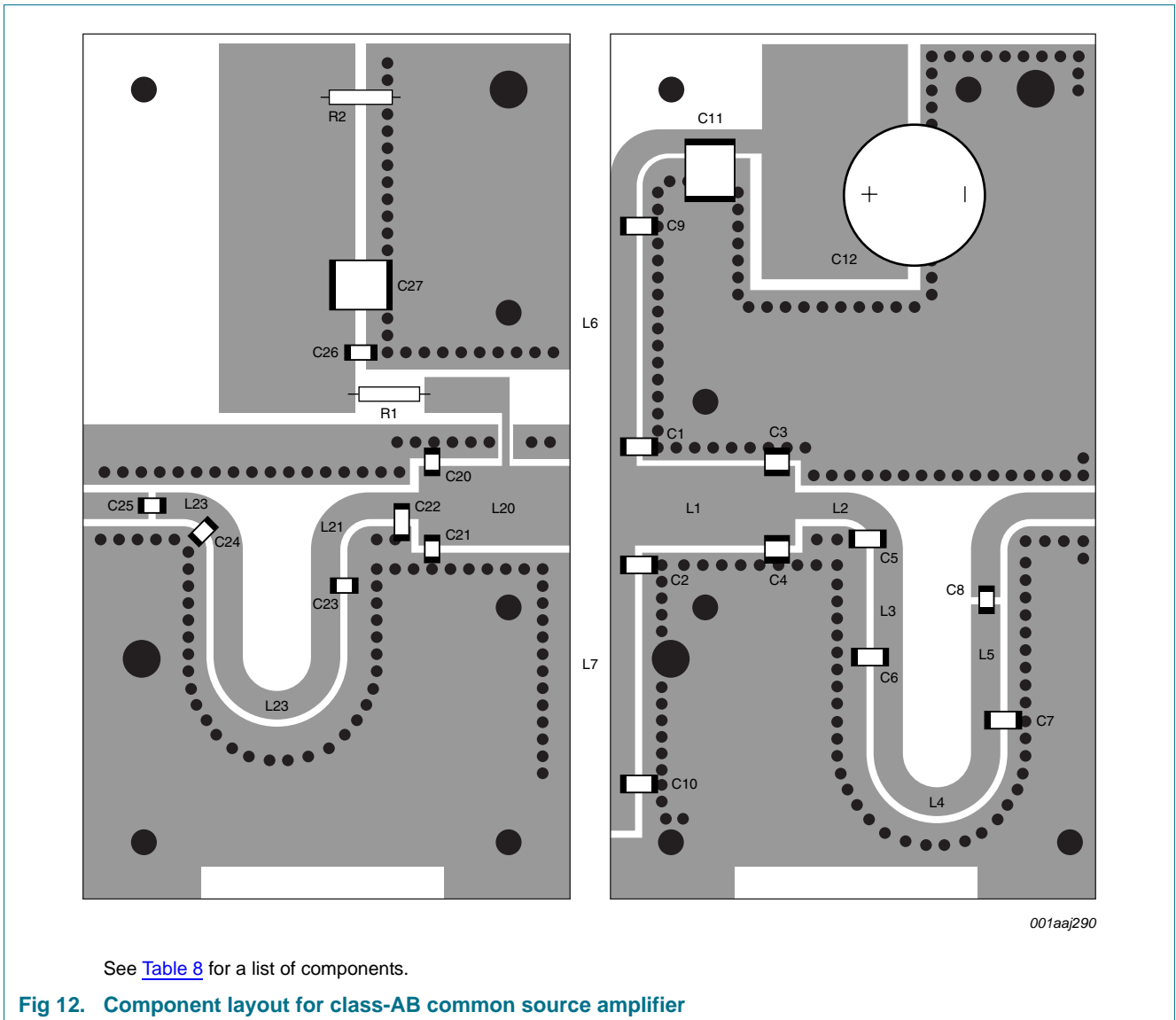

**9. Package outline**

Flanged LDMOST ceramic package; 2 mounting holes; 2 leads

SOT467C

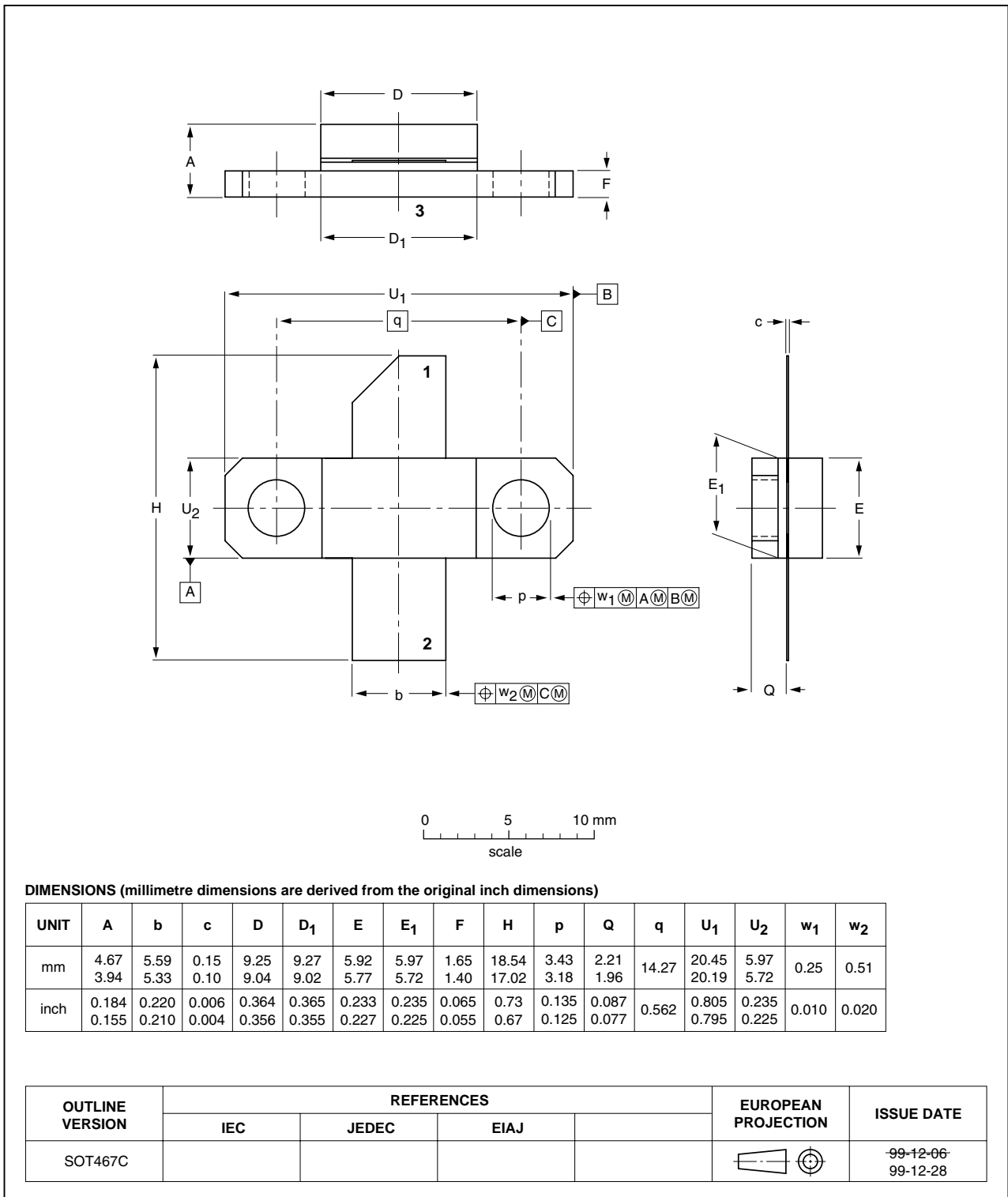

Fig 13. Package outline SOT467C

Earless LDMOST ceramic package; 2 leads

SOT467B

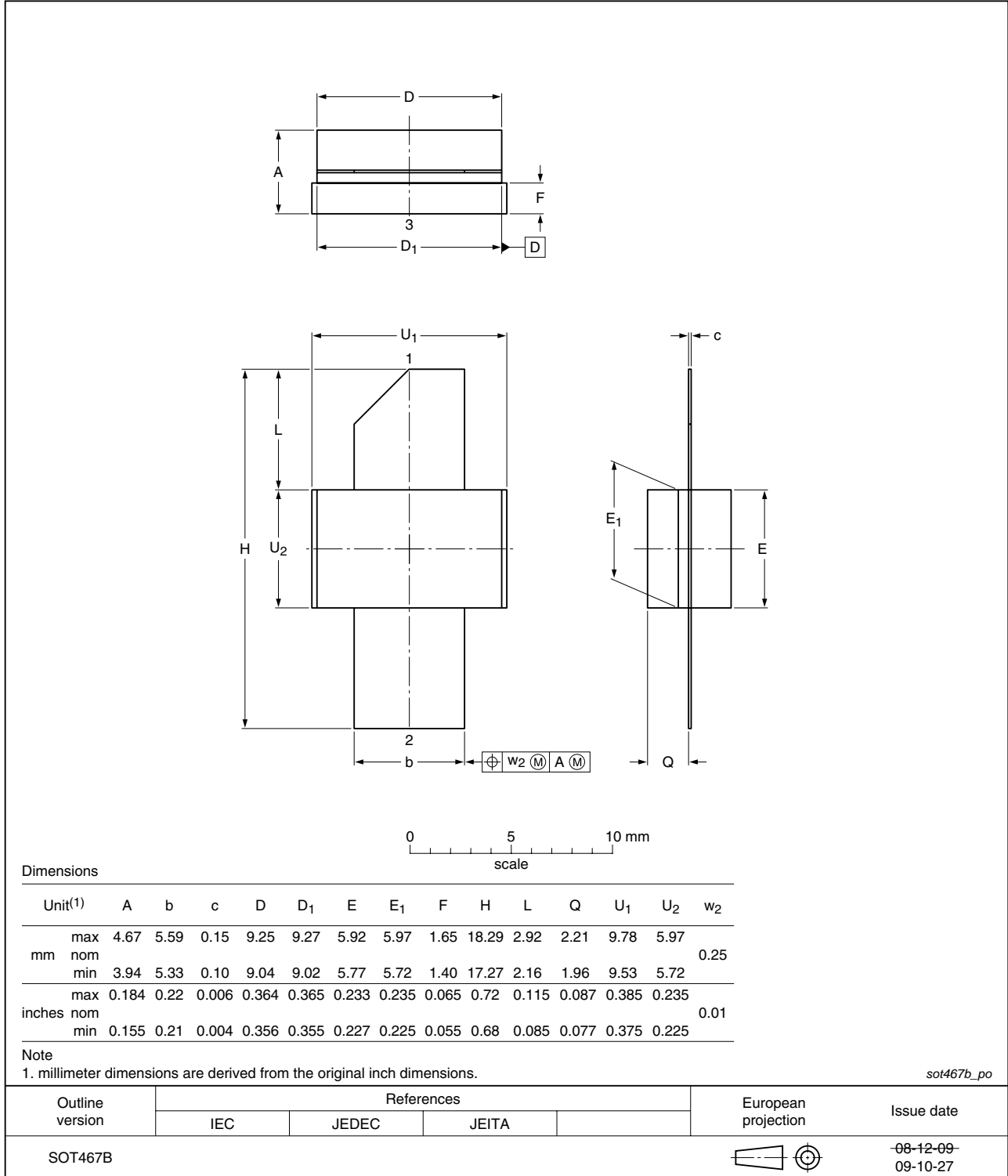

Fig 14. Package outline SOT467B

## 10. Abbreviations

Table 9. Abbreviations

Acronym	Description
CW	Continuous Wave
CCDF	Complementary Cumulative Distribution Function
DVB	Digital Video Broadcast
DVB-T	Digital Video Broadcast - Terrestrial
ESD	ElectroStatic Discharge
HF	High Frequency
IMD3	Third order InterModulation Distortion
LDMOS	Laterally Diffused Metal-Oxide Semiconductor
LDMOST	Laterally Diffused Metal-Oxide Semiconductor Transistor
OFDM	Orthogonal Frequency Division Multiplexing
PAR	Peak-to-Average power Ratio
PEP	Peak Envelope Power
RF	Radio Frequency
TTF	Time To Failure
UHF	Ultra High Frequency
VSWR	Voltage Standing-Wave Ratio

## 11. Revision history

Table 10. Revision history

Document ID	Release date	Data sheet status	Change notice	Supersedes
BLF881_BLF881S v.3	20101207	Product data sheet	-	BLF881_BLF881S v.2
Modifications:	<ul style="list-style-type: none"> <li>• <a href="#">Table 6 on page 3</a>: In the conditions column of <math>V_{GS(th)}</math> the value of <math>I_D</math> has been changed</li> </ul>			
BLF881_BLF881S v.2	20100210	Product data sheet	-	BLF881_BLF881S v.1
BLF881_BLF881S v.1	20091210	Preliminary data sheet	-	-

## 12. Legal information

### 12.1 Data sheet status

Document status <sup>[1][2]</sup>	Product status <sup>[3]</sup>	Definition
Objective [short] data sheet	Development	This document contains data from the objective specification for product development.
Preliminary [short] data sheet	Qualification	This document contains data from the preliminary specification.
Product [short] data sheet	Production	This document contains the product specification.

[1] Please consult the most recently issued document before initiating or completing a design.

[2] The term 'short data sheet' is explained in section "Definitions".

[3] The product status of device(s) described in this document may have changed since this document was published and may differ in case of multiple devices. The latest product status information is available on the Internet at URL <http://www.nxp.com>.

### 12.2 Definitions

**Draft** — The document is a draft version only. The content is still under internal review and subject to formal approval, which may result in modifications or additions. NXP Semiconductors does not give any representations or warranties as to the accuracy or completeness of information included herein and shall have no liability for the consequences of use of such information.

**Short data sheet** — A short data sheet is an extract from a full data sheet with the same product type number(s) and title. A short data sheet is intended for quick reference only and should not be relied upon to contain detailed and full information. For detailed and full information see the relevant full data sheet, which is available on request via the local NXP Semiconductors sales office. In case of any inconsistency or conflict with the short data sheet, the full data sheet shall prevail.

**Product specification** — The information and data provided in a Product data sheet shall define the specification of the product as agreed between NXP Semiconductors and its customer, unless NXP Semiconductors and customer have explicitly agreed otherwise in writing. In no event however, shall an agreement be valid in which the NXP Semiconductors product is deemed to offer functions and qualities beyond those described in the Product data sheet.

### 12.3 Disclaimers

**Limited warranty and liability** — Information in this document is believed to be accurate and reliable. However, NXP Semiconductors does not give any representations or warranties, expressed or implied, as to the accuracy or completeness of such information and shall have no liability for the consequences of use of such information.

In no event shall NXP Semiconductors be liable for any indirect, incidental, punitive, special or consequential damages (including - without limitation - lost profits, lost savings, business interruption, costs related to the removal or replacement of any products or rework charges) whether or not such damages are based on tort (including negligence), warranty, breach of contract or any other legal theory.

Notwithstanding any damages that customer might incur for any reason whatsoever, NXP Semiconductors' aggregate and cumulative liability towards customer for the products described herein shall be limited in accordance with the *Terms and conditions of commercial sale* of NXP Semiconductors.

**Right to make changes** — NXP Semiconductors reserves the right to make changes to information published in this document, including without limitation specifications and product descriptions, at any time and without notice. This document supersedes and replaces all information supplied prior to the publication hereof.

**Suitability for use** — NXP Semiconductors products are not designed, authorized or warranted to be suitable for use in life support, life-critical or safety-critical systems or equipment, nor in applications where failure or

malfunction of an NXP Semiconductors product can reasonably be expected to result in personal injury, death or severe property or environmental damage. NXP Semiconductors accepts no liability for inclusion and/or use of NXP Semiconductors products in such equipment or applications and therefore such inclusion and/or use is at the customer's own risk.

**Applications** — Applications that are described herein for any of these products are for illustrative purposes only. NXP Semiconductors makes no representation or warranty that such applications will be suitable for the specified use without further testing or modification.

Customers are responsible for the design and operation of their applications and products using NXP Semiconductors products, and NXP Semiconductors accepts no liability for any assistance with applications or customer product design. It is customer's sole responsibility to determine whether the NXP Semiconductors product is suitable and fit for the customer's applications and products planned, as well as for the planned application and use of customer's third party customer(s). Customers should provide appropriate design and operating safeguards to minimize the risks associated with their applications and products.

NXP Semiconductors does not accept any liability related to any default, damage, costs or problem which is based on any weakness or default in the customer's applications or products, or the application or use by customer's third party customer(s). Customer is responsible for doing all necessary testing for the customer's applications and products using NXP Semiconductors products in order to avoid a default of the applications and the products or of the application or use by customer's third party customer(s). NXP does not accept any liability in this respect.

**Limiting values** — Stress above one or more limiting values (as defined in the Absolute Maximum Ratings System of IEC 60134) will cause permanent damage to the device. Limiting values are stress ratings only and (proper) operation of the device at these or any other conditions above those given in the Recommended operating conditions section (if present) or the Characteristics sections of this document is not warranted. Constant or repeated exposure to limiting values will permanently and irreversibly affect the quality and reliability of the device.

**Terms and conditions of commercial sale** — NXP Semiconductors products are sold subject to the general terms and conditions of commercial sale, as published at <http://www.nxp.com/profile/terms>, unless otherwise agreed in a valid written individual agreement. In case an individual agreement is concluded only the terms and conditions of the respective agreement shall apply. NXP Semiconductors hereby expressly objects to applying the customer's general terms and conditions with regard to the purchase of NXP Semiconductors products by customer.

**No offer to sell or license** — Nothing in this document may be interpreted or construed as an offer to sell products that is open for acceptance or the grant, conveyance or implication of any license under any copyrights, patents or other industrial or intellectual property rights.

**Export control** — This document as well as the item(s) described herein may be subject to export control regulations. Export might require a prior authorization from national authorities.

**Non-automotive qualified products** — Unless this data sheet expressly states that this specific NXP Semiconductors product is automotive qualified, the product is not suitable for automotive use. It is neither qualified nor tested in accordance with automotive testing or application requirements. NXP Semiconductors accepts no liability for inclusion and/or use of non-automotive qualified products in automotive equipment or applications.

In the event that customer uses the product for design-in and use in automotive applications to automotive specifications and standards, customer (a) shall use the product without NXP Semiconductors' warranty of the product for such automotive applications, use and specifications, and (b) whenever customer uses the product for automotive applications beyond NXP Semiconductors' specifications such use shall be solely at customer's own risk, and (c) customer fully indemnifies NXP Semiconductors for any liability, damages or failed product claims resulting from customer design and use of the product for automotive applications beyond NXP Semiconductors' standard warranty and NXP Semiconductors' product specifications.

## 13. Contact information

For more information, please visit: <http://www.nxp.com>

For sales office addresses, please send an email to: [salesaddresses@nxp.com](mailto:salesaddresses@nxp.com)

## 12.4 Licenses

### ICs with DVB-T or DVB-T2 functionality

Use of this product in any manner that complies with the DVB-T or the DVB-T2 standard may require licenses under applicable patents of the DVB-T respectively the DVB-T2 patent portfolio, which license is available from Sisvel S.p.A., Via Sestriere 100, 10060 None (TO), Italy, and under applicable patents of other parties.

## 12.5 Trademarks

Notice: All referenced brands, product names, service names and trademarks are the property of their respective owners.

**14. Contents**

**1 Product profile . . . . . 1**

1.1 General description . . . . . 1

1.2 Features and benefits . . . . . 1

1.3 Applications . . . . . 2

**2 Pinning information . . . . . 2**

**3 Ordering information . . . . . 2**

**4 Limiting values . . . . . 3**

**5 Thermal characteristics . . . . . 3**

**6 Characteristics . . . . . 3**

**7 Application information . . . . . 5**

7.1 Narrowband RF figures . . . . . 5

7.1.1 CW . . . . . 5

7.1.2 2-Tone . . . . . 5

7.1.3 DVB-T . . . . . 6

7.2 Broadband RF figures . . . . . 7

7.2.1 DVB-T . . . . . 7

7.3 Ruggedness in class-AB operation . . . . . 7

7.4 Reliability . . . . . 8

**8 Test information . . . . . 9**

**9 Package outline . . . . . 13**

**10 Abbreviations . . . . . 15**

**11 Revision history . . . . . 15**

**12 Legal information . . . . . 16**

12.1 Data sheet status . . . . . 16

12.2 Definitions . . . . . 16

12.3 Disclaimers . . . . . 16

12.4 Licenses . . . . . 17

12.5 Trademarks . . . . . 17

**13 Contact information . . . . . 17**

**14 Contents . . . . . 18**

Please be aware that important notices concerning this document and the product(s) described herein, have been included in section 'Legal information'.

© NXP B.V. 2010. All rights reserved.

For more information, please visit: <http://www.nxp.com>  
 For sales office addresses, please send an email to: [salesaddresses@nxp.com](mailto:salesaddresses@nxp.com)

Date of release: 7 December 2010  
 Document identifier: BLF881\_BLF881S



LittleDiode supplies new, hard to find or obsolete electronic components and semiconductors all over the world.

With over two million different components listed you are sure to find the part you need.

Feel free to visit us today at our online store:

**[LittleDiode.com](http://LittleDiode.com)**

Looking forward to providing you with the best possible service.