

# PLL frequency synthesizer for tuners

## BU2614 / BU2614FS

The BU2614 PLL frequency synthesizers work up through the FM band. Featuring low radiation noise, low power dissipation, and highly sensitive built-in RF amps, they support an IF count function.

### ●Applications

Tuners (Mini components, radio cassette players, radio equipment, etc.)

### ●Features

- 1) Built-in high-speed prescaler can divide 130MHzVCO.
- 2) Reference oscillation of 75kHz keeps unnecessary radiation noise to a low level.
- 3) Low current dissipation (during operation: 4mA, PLL OFF 100 $\mu$ A).
- 4) In addition to the standard FM and AM, also offers the following 7 frequencies: 25kHz, 12.5kHz, 6.25kHz, 3.125kHz, 5kHz, 3kHz, and 1kHz.
- 5) Counter for measurement of intermediate frequencies.
- 6) Unlock detection.
- 7) Three output ports (open drain).  
The BU2615, with seven output ports, is also available.
- 8) Serial data input (CE, CK, DA).

### ●Absolute maximum ratings (Ta = 25°C)

Parameter		Symbol	Limits	Unit	Conditions
Power supply voltage		V <sub>DD</sub>	-0.3~+7.0	V	V <sub>DD1</sub> , V <sub>DD2</sub>
Maximum input voltage 1		V <sub>IN1</sub>	-0.3~+7.0	V	CE,CK,DA
Maximum input voltage 2		V <sub>IN2</sub>	-0.3~V <sub>DD</sub> +0.3	V	XIN,FMIN,AMIN,IFIN
Maximum output voltage 1		V <sub>OUT1</sub>	-0.3~+10.0	V	P <sub>0</sub> , P <sub>1</sub> , P <sub>2</sub> , CD
Maximum output voltage 2		V <sub>OUT2</sub>	-0.3~V <sub>DD</sub> 0.3	V	PD <sub>1</sub> , XOUT
Maximum output current		I <sub>OUT</sub>	0~+3.0	mA	P <sub>0</sub> , P <sub>1</sub> , P <sub>2</sub> , CD
Power dissipation	BU2614	P <sub>D</sub>	1000* <sup>1</sup>	mW	
	BU2614FS		500* <sup>2</sup>		
Operating temperature		T <sub>opr</sub>	-10~+75	°C	
Storage temperature		T <sub>stg</sub>	-55~+125	°C	

\*1 Reduced by 10mW for each increase in Ta of 1°C over 25°C.

\*2 Reduced by 5mW for each increase in Ta of 1°C over 25°C.

### ●Recommended operating conditions (Ta = 25°C)

Parameter	Symbol	Limits	Unit
Power supply voltage	V <sub>DD1</sub>	2.7~6.0	V
	V <sub>DD2</sub>	4.0~6.0	V

● Block diagram

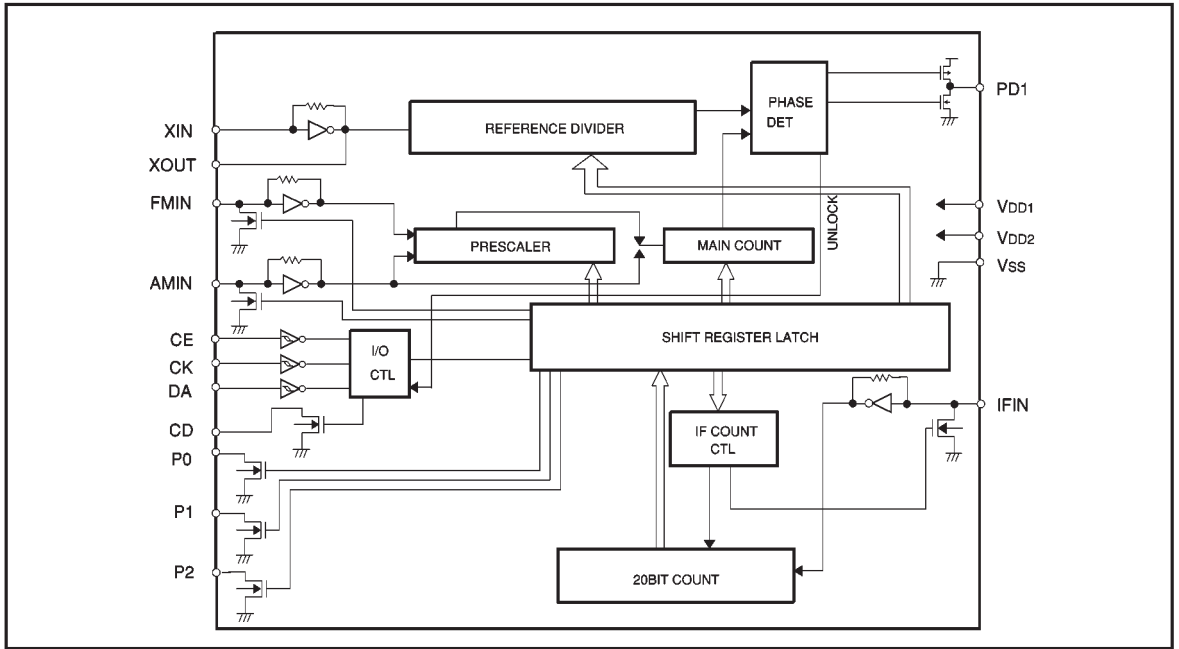

● Pin assignments

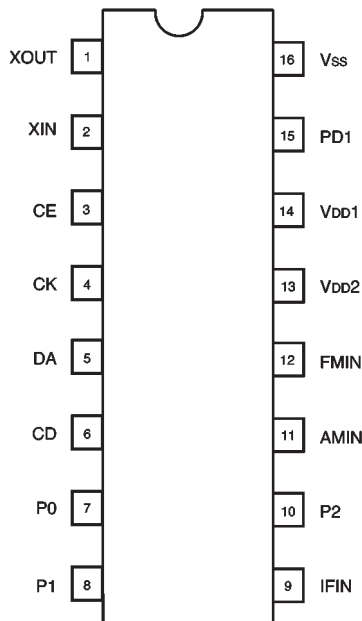

## ● Pin descriptions

Pin No.	Symbol	Pin name	Function	I / O
1	XOUT	Crystal oscillation	For generation of standard frequency and internal clock.	OUT
2	XIN		Connected to 75 kHz crystal resonator.	IN
3	CE	Chip enable	When CE is H, DA is synchronous with the rise of CK and read to the internal shift register. DA is then latched at the timing of the fall of CE. Also, output data is output from the CD terminal synchronous to the rise of CK.	IN
4	CK	Serial data		
5	DA	Clock signal		
6	CD	Count data	Frequency data and unlock data are output.	Nch open drain
7	P0	Output port	Controlled on the basis of input data.	
8	P1			
9	IFIN	IF input	Input for frequency measurement.	IN
10	P2	Output port	Controlled on the basis of input data.	Nch open drain
11	AMIN	AM input	Local input for AM	IN
12	FMIN	FM input	Local input for FM	IN
13	V <sub>DD2</sub>	Power supply 2	4.0V to 6.0V applied for high-speed circuit power supply.	—
14	V <sub>DD1</sub>	Power supply 1	Power supply for logic. 2.7V to 6.0V	—
15	PD1	Phase comparison output	High level when value obtained by dividing local output is higher than standard frequency. Low level when value is lower. High impedance when value is same.	3-state
16	V <sub>SS</sub>	GROUND		

●Electrical characteristics (unless otherwise noted, Ta = 25°C, V<sub>DD1</sub> = V<sub>DD2</sub> = 5.0V)

Parameter	Symbol	Min.	Typ.	Max.	Unit	Conditions
Power supply current 1	I <sub>DD1</sub>	—	5.0	10.0	mA	F <sub>MIN</sub> =130MHz, 100mV <sub>rms</sub> 13-pin current
Power supply current 2	I <sub>DD2</sub>	—	100	150	μA	14-pin current
Quiescent current	I <sub>DD3</sub>	—	150	300	μA	No input,, PLL=OFF 13-pin current
Input high level voltage	V <sub>IH</sub>	4.0	—	—	V	CE, CK, DA terminals
Input low level voltage	V <sub>IL</sub>	—	—	1.0	V	CE, CK, DA terminals
Input high level current 1	I <sub>IH1</sub>	—	—	1.0	μA	CE, CK, DA terminals V <sub>IN</sub> =V <sub>DD</sub>
Input high level current 2	I <sub>IH2</sub>	—	0.3	—	μA	XIN terminal V <sub>IN</sub> =V <sub>DD</sub>
Input high level current 3	I <sub>IH3</sub>	—	6.0	—	μA	FMIN, AMIN, IFIN terminals V <sub>IN</sub> =V <sub>DD</sub>
Input low level current 1	I <sub>IL1</sub>	-1.0	—	—	μA	CE, CK, DA terminals V <sub>IN</sub> =V <sub>SS</sub>
Input low level current 2	I <sub>IL2</sub>	—	-0.3	—	μA	XIN terminals V <sub>IN</sub> =V <sub>SS</sub>
Input low level current 3	I <sub>IL3</sub>	—	-6.0	—	μA	FMIN, AMIN, IFIN terminals V <sub>IN</sub> =V <sub>SS</sub>
Output low level voltage 1	V <sub>OL1</sub>	—	0.2	0.5	V	Po, P1, P2, CD I <sub>O</sub> =1.0mA
Off level leakage current 1	I <sub>OFF1</sub>	—	—	1.0	μA	Po, P1, P2, CD V <sub>O</sub> =10V
Output low level voltage 2	V <sub>OL2</sub>	—	0.1	0.5	V	FMIN, AMIN, IFIN I <sub>OUT</sub> =0.1mA
Output high level voltage	V <sub>OH</sub>	V <sub>DD</sub> -1.0	V <sub>DD</sub> -0.3	—	V	PD1 I <sub>OUT</sub> =-1.0mA
Output low level voltage	V <sub>OL</sub>	—	0.2	1.0	V	PD1 I <sub>OUT</sub> =1.0mA
Off level leakage current 2	I <sub>OFF2</sub>	—	—	100	nA	PD1 V <sub>OUT</sub> =V <sub>DD</sub>
Off level leakage current 3	I <sub>OFF3</sub>	-100	—	—	nA	PD1 V <sub>OUT</sub> =V <sub>SS</sub>
Internal feedback resistor 1	R <sub>F1</sub>	—	10	—	MΩ	XIN
Internal feedback resistor 2	R <sub>F2</sub>	—	500	—	kΩ	FMIN, ANIN, IFIN
Input frequency 1	F <sub>IN1</sub>	10	75	160	kHz	XIN, sine wave, C coupling
Input frequency 2	F <sub>IN2</sub>	10	—	130	MHz	FMIN, sine wave, C coupling V <sub>IN</sub> =50mV <sub>rms</sub>
Input frequency 3	F <sub>IN3</sub>	0.4	—	30	MHz	AMIN1, sine wave, C coupling V <sub>IN</sub> =70mV <sub>rms</sub>
Input frequency 4	F <sub>IN4</sub>	0.4	—	16	MHz	IFIN, sine wave, C coupling V <sub>IN</sub> =70mV <sub>rms</sub>
Maximum input amplitude	F <sub>INMAX</sub>	—	—	1.5	V <sub>rms</sub>	XIN, FMIN, AMIN, IFIN, sine wave, C coupling
Minimum pulse width	TW	—	1.0	—	μs	CK, DA
Input rise time	TR	—	—	500	ns	CE, CK, DA
Input fall time	TF	—	—	500	ns	CE, CK, DA

● Input data format

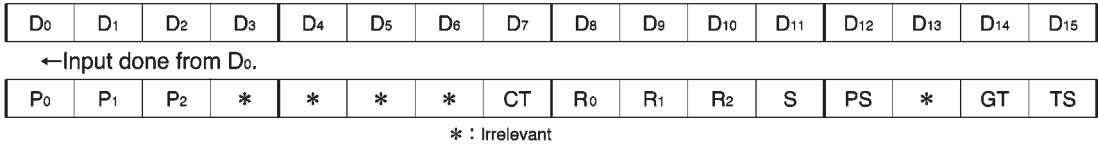
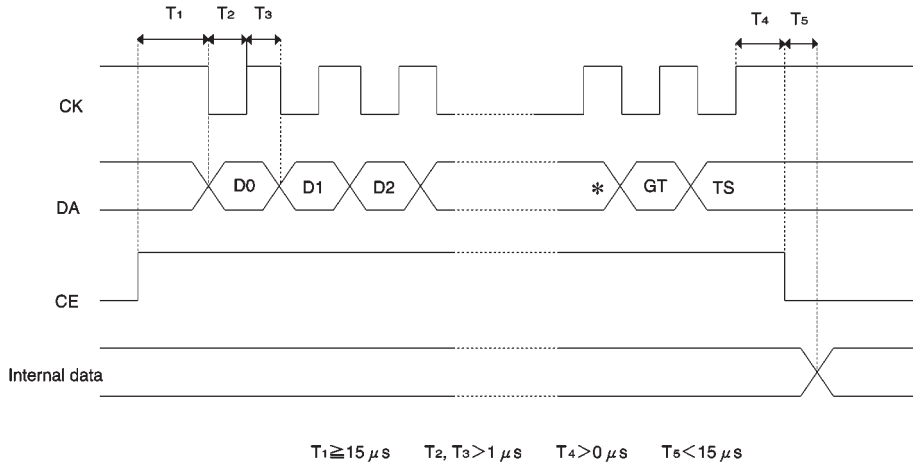

Output data format CE output is LO.

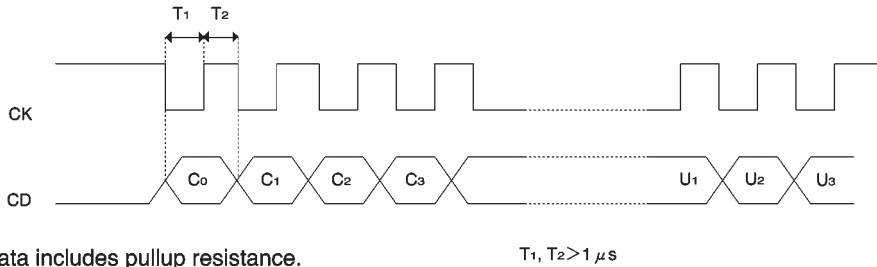

Output data includes pullup resistance.

Output data format

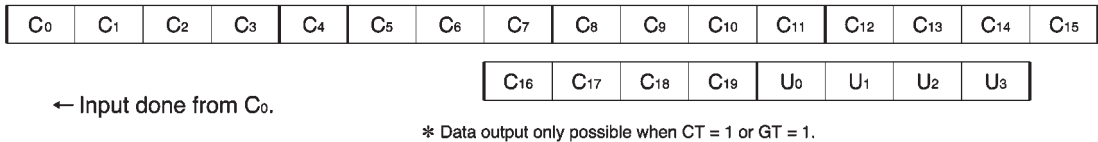

●Explanation of the data

(1) Division data: For D<sub>0</sub> through D<sub>15</sub> (When S = 1, use D<sub>4</sub> through D<sub>15</sub>.)

D <sub>0</sub>	D <sub>1</sub>	D <sub>2</sub>	D <sub>3</sub>	D <sub>4</sub>	D <sub>5</sub>	D <sub>6</sub>	D <sub>7</sub>	D <sub>8</sub>	D <sub>9</sub>	D <sub>10</sub>	D <sub>11</sub>	D <sub>12</sub>	D <sub>13</sub>	D <sub>14</sub>	D <sub>15</sub>
----------------	----------------	----------------	----------------	----------------	----------------	----------------	----------------	----------------	----------------	-----------------	-----------------	-----------------	-----------------	-----------------	-----------------

Examples:

Divide ratio=1100(D)÷2=550(D)=226(H) S=0, PS=0 Divide ratio is double the set value.

0 1 1 0 ∥ 0 1 0 0 ∥ 0 1 0 0 ∥ 0 0 0 0

Divide ratio=1107(D)=453(H) S=1, PS=1

1 1 0 0 ∥ 1 0 1 0 ∥ 0 0 1 0 ∥ 0 0 0 0

Divide ratio=926(D)=39E(H) S=1, PS=0

× × × × ∥ 0 1 1 1 ∥ 1 0 0 1 ∥ 1 1 0 0

(2) CT: Frequency measurement beginning data

1: Beginning of measurement

0: Internal counter is reset, IFIN is pulldown.

(3) Output port control data: P0, P1, P2

1: Open drain output ON

2: Open drain output OFF

(4) R<sub>0</sub>, R<sub>1</sub>, R<sub>2</sub>, standard frequency data

Data			Standard frequency
R0	R1	R2	
0	0	0	25kHz
0	0	1	12.5kHz
0	1	0	6.25kHz
0	1	1	5kHz
1	0	0	3.125kHz
1	0	1	3kHz
1	1	0	1kHz
1	1	1	*PLL OFF

\* FMIN = pulldown, AMIN = pulldown, PD = high impedance

(5) S: switch between FMIN and AMIN 0: FMIN

1: AMIN

(6) PS: If this bit is set to ON while AMIN is selected, swallow counter division is possible.

(7) GT: Frequency measurement time and unlock detection ON/OFF

CT	GT	Frequency measurement	Unlock detection	Data output
0	0	OFF	OFF	NG
0	1	OFF	ON	
1	0	ON gate time 16 ms	ON	OK
1	1	ON gate time 32 ms	ON	

(8) TS: Test data (0) is input.

● Frequency counter

(1) Structure

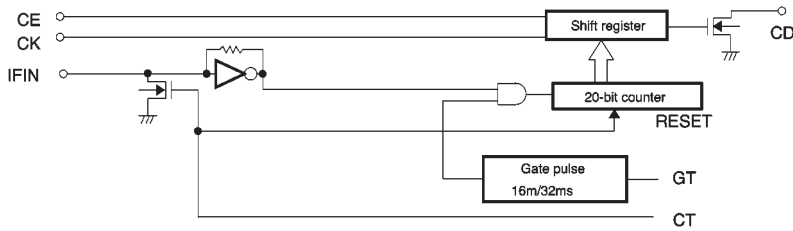

(2) How the frequency counter operates

When control data CT equals 1, the 20-bit counter and the amp go into operation. When CT equals 0, input pull-down and the counter are reset. Measuring time (gate pulse) is selected (16ms/32ms) on the basis of control data GT. When control data CT equals 0, the counter is reset.

(3) Explanation of output data

D<sub>0</sub>: LSB D<sub>19</sub>: MSB

How the unlock detection circuit operates

When control data GT equals 1, or CT equals 1, the unlock detection circuit goes into operation for 8ms. When CT equals 1, the unlock detection circuit stops operating before the frequency counter gate pulse is emitted.

When CT equals 0, or GT equals 0, the unlock detection circuit is reset.

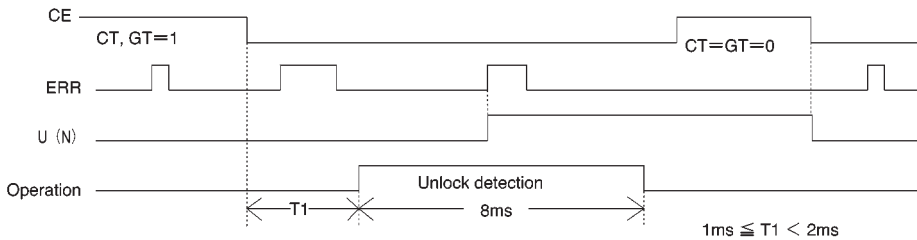

Explanation of output data

U0	U1	U2	U3	
0	0	0	0	ERR < 7 μs
1	0	0	0	7 μs < ERR < 13 μs
1	1	0	0	13 μs < ERR < 26 μs
1	1	1	0	26 μs < ERR < 54 μs
1	1	1	1	54 μs < ERR

● How the frequency counter and unlock detection circuit operate

(1) When CT = 1: Frequency count and unlock detection are carried out.

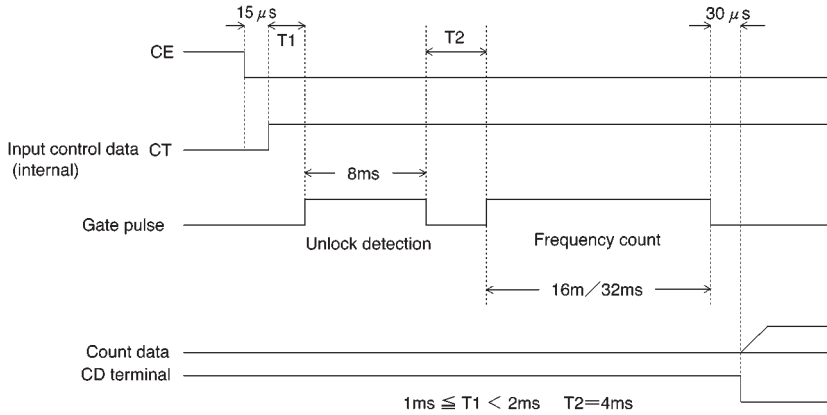

(2) When CT = 0 and GT = 1: Only unlock detection is carried out.

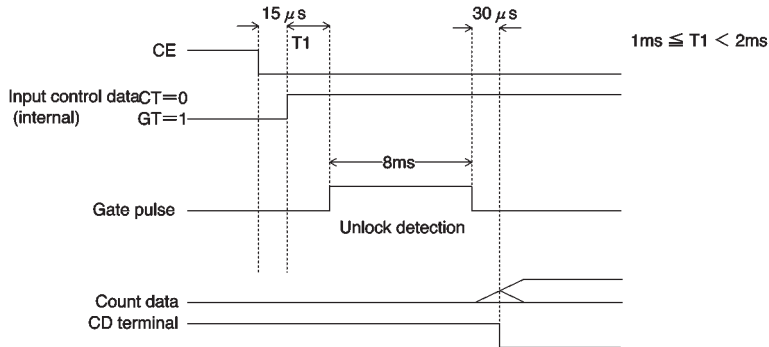

Explanation of CD terminal

When frequency measurement or unlock detection is finished, the CD terminal goes to LO to indicate that the count and unlock detection have finished.

It also synchronizes with CK to output counter data. When the next data is input, it goes to HI.

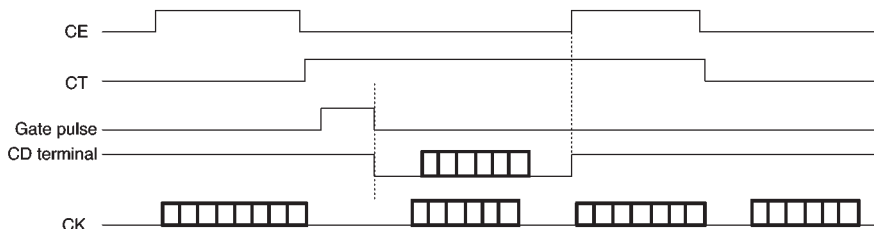

● External dimensions (Units: mm)

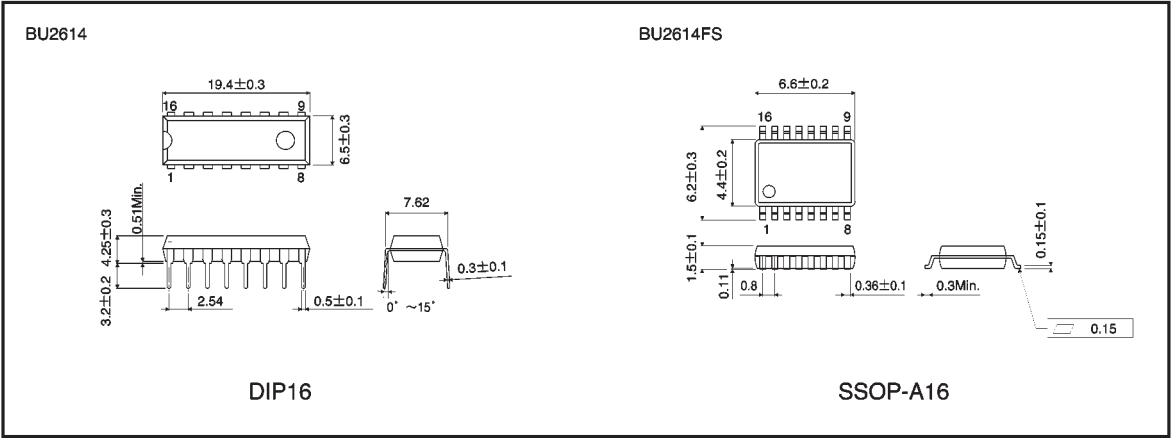

This datasheet has been downloaded from:

[www.DatasheetCatalog.com](http://www.DatasheetCatalog.com)

Datasheets for electronic components.



LittleDiode supplies new, hard to find or obsolete electronic components and semiconductors all over the world.

With over two million different components listed you are sure to find the part you need.

Feel free to visit us today at our online store:

[LittleDiode.com](http://LittleDiode.com)

Looking forward to providing you with the best possible service.