

Dual PLL frequency synthesizer

BU2630F / BU2630FV

The BU2630F/BU2630FV are a CMOS LSI with an internal dual PLL synthesizer.

VCOs for transmission and reception can be controlled independently, and the reference frequency and main counter settings can also be programmed separately. This product is designed for applications involving cordless telephones and communications equipment worldwide.

●Applications

Cordless telephones, amateur short wave radios, industrial transceivers, VHF/UHF frequency generators, and others

●Features

- | | |
|--|---|
| 1) Operation possible at up to 80MHz ($V_{DD} = 2.5$). | 3) 16-bit main counter. |
| 2) Low current dissipation | 4) Internal 14-bit reference frequency counter. |
| Dual-system operation : 2.2mA (typ), $V_{DD} = 3V$ | 5) Unlock detection possible. |
| Single-system operation : 1.2mA (typ), $V_{DD} = 3V$ | 6) Four output ports. (open drain) |
| Non-operating state : 0.2mA (typ), $V_{DD} = 3V$ | 7) Control possible using 3-wire serial input. |

●Block diagram

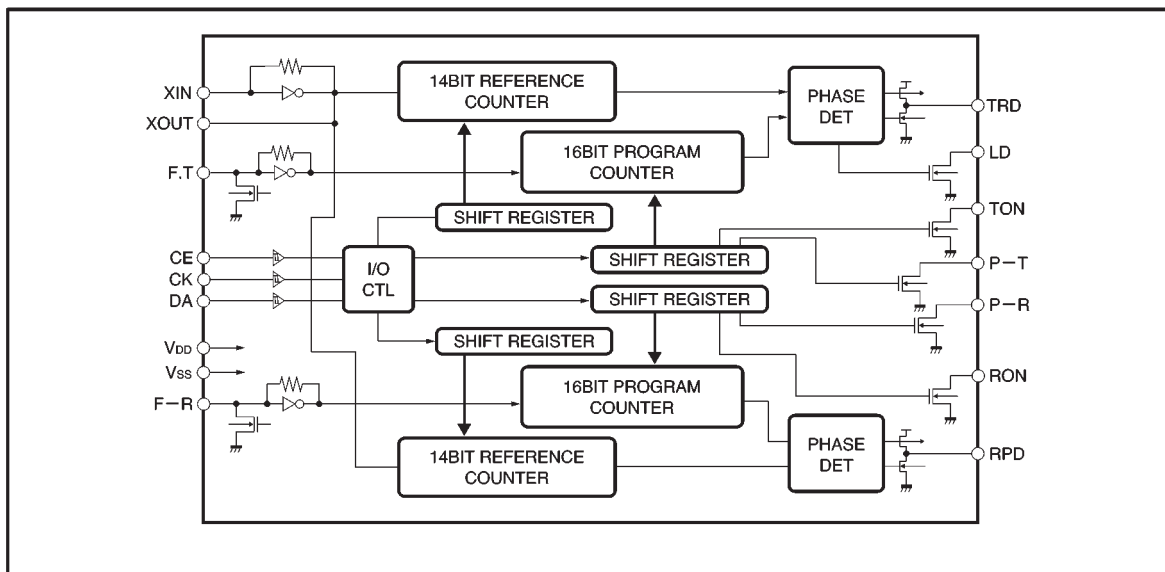

● Absolute maximum ratings (Ta = 25°C)

Parameter	Symbol	Limits	Unit
Power supply voltage	V _{DD}	-0.3~+7.0	V
Power dissipation	BU2630F	Pd	mW
	BU2630FV		
			350*2
Operating temperature	T _{opr}	-40~+85	°C
Storage temperature	T _{stg}	-55~+125	°C

*1 Reduced by 5.0mW for each increase in Ta of 1°C over 25°C.

*2 Reduced by 3.5mW for each increase in Ta of 1°C over 25°C.

● Recommended operating conditions (Ta = 25°C)

Parameter	Symbol	Min.	Typ.	Max.	Unit
Power supply voltage	V _{DD}	2.5	3.0	5.5	V

● Pin descriptions

Pin No.	Pin name	Name	Function	I/O circuit
16	XOUT	Crystal resonator	For reference frequency	TYPE A
1	XIN			
2	V _{SS}			
3	RPD	Phase comparator output	This is LO if the locally divided value is higher than the reference frequency, HI if it is lower, and Z if it matches.	TYPE E
4	P-R	Output port	This is controlled by the input data.	TYPE D
5	RON			
6	F-R	VCO input	Local input for reception	TYPE F
7	CE	Chip enable clock signal serial data	When CE is HIGH, the DA synchronized to the rise of CK is read into the internal shift register, and is latched at the timing of the CE fall.	TYPE B
8	CK			
9	DA			
10	LD	Unlock output	This goes ON when the PLL is unlocked on the transmission side	TYPE D
11	F-T	VCO input	Local input for transmission	TYPE F
12	TON	Output port	This is controlled by the input data	TYPE D
13	P-T			
14	TPD	Phase comparator output	This is LO if the locally divided value is higher than the reference frequency, HI if it is lower, and Z if it matches.	TYPE E
15	V _{DD}	Power supply	2.5~5.5V	

● Input/output circuits

TYPE A

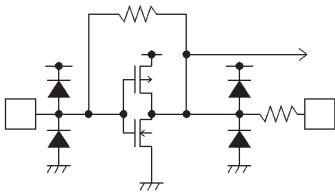

TYPE B

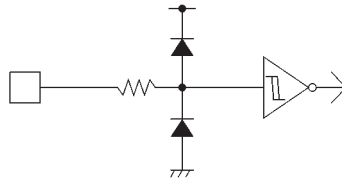

TYPE C

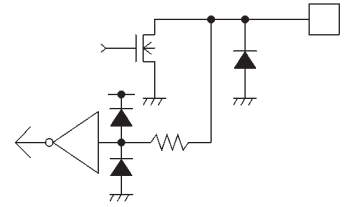

TYPE D

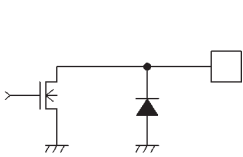

TYPE E

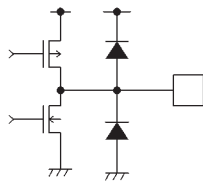

TYPE F

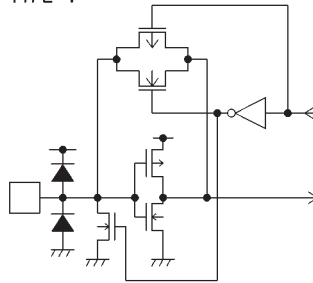

TYPE I

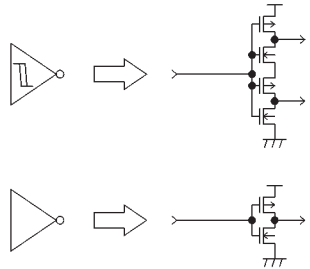

● Electrical characteristics (unless otherwise noted, Ta = 25°C, VDD = 3.0V, VSS = 0V)

Parameter	Symbol	Min.	Typ.	Max.	Unit	Conditions
Power supply current 1	IDD1	—	2.2	3.0	mA	Dual-system operation
Power supply current 2	IDD2	—	1.2	2.0	mA	Single-system operation
Power supply current 3	IDD3	—	0.2	0.3	mA	With operation stopped: XTAL = 10.24 MHz
Input high level voltage 1	VIH1	0.8VDD	—	—	V	CE CK DA
Input low level voltage 1	VIL1	—	—	0.2VDD	V	CE CK DA
Input high level current 1	I IH1	—	—	1.0	μA	CE CK DA VIN=VDD
Input high level current 2	I IH2	—	0.3	—	μA	XIN VIN=VDD
Input high level current 3	I IH3	—	5.0	—	μA	F-T F-R VIN=VDD
Input low level current 1	I IL1	-1.0	—	—	μA	CE CK DA VIN=VSS
Input low level current 2	I IL2	—	-0.3	—	μA	XIN VIN=VSS
Input low level current 3	I IL3	—	-5.0	—	μA	F-T F-R VIN=VSS
Output low level voltage 1	VOL1	—	0.3	0.5	V	LD TON P-T RON P-R I O=1.0mA
Off level leakage current 1	I OFF1	—	—	1.0	μA	LD TON P-T RON P-R VO=10V
Output low level voltage 2	VOL2	—	—	0.3	V	F-T F-R I OUT=0.1mA
Output high level voltage	VOH3	VDD-50	VDD-1.0	—	mV	TPD RPD I OUT=-0 μA
Output low level voltage	VOL3	—	1.3	50	mV	TPD RPD I OUT=0 μA
Output high level voltage	VOH4	VDD-100	VDD-40	—	mV	TPD RPD I OUT=-100 μA
Output low level voltage	VOL4	—	30	100	mV	TPD RPD I OUT=100 μA
Off level leakage current 2	I OFF2	—	—	100	nA	TPD RPD V OUT=VDD
Off level leakage current 3	I OFF3	-100	—	—	nA	TPD RPD V OUT=VSS
Internal feedback resistance 1	RF1	—	10	—	MΩ	XIN
Internal feedback resistance 2	RF2	—	500	—	kΩ	F-T F-R
Input frequency 1	F IN1	1.0	10.24	16.0	MHz	XIN, sine wave, C coupling
Input frequency 2	F IN2	1.0	—	20	MHz	F-T F-R, sine wave, C coupling*2, VIN = 100 mVrms
Input frequency 3	F IN3	50	—	80	MHz	F-T F-R, sine wave, C coupling*2, VIN = 100 mVrms
Input frequency 4	F IN4	20	—	50	MHz	F-T F-R, sine wave, C coupling*2, VIN = 50 mVrms
Input frequency 5*1	F IN5	0.4	—	20	MHz	F-T F-R, sine wave, C coupling*2, VIN =100mVrms
Maximum input amplitude	F INMax.	—	—	VDD+0.3	Vp-p	XIN, F-T F-R
Input capacitance	C IN	—	4	7	PF	F-T F-R
Minimum pulse width	TW	1.0	—	—	μs	CK, DA
Input data rise time	TR	—	—	300	ns	CK, DA
Input data fall time	TF	—	—	300	ns	CE, CK, DA

© Not designed for radiation resistance.

*1 PS = 1

*2 Minimum input level at which operation is possible

Divider values which can be set

Program divider: PS = 0: 256 to 65535, PS = 1: 3 to 4095

Reference frequency divider: 3 to 16383

●Circuit operation

Input data switching characteristics

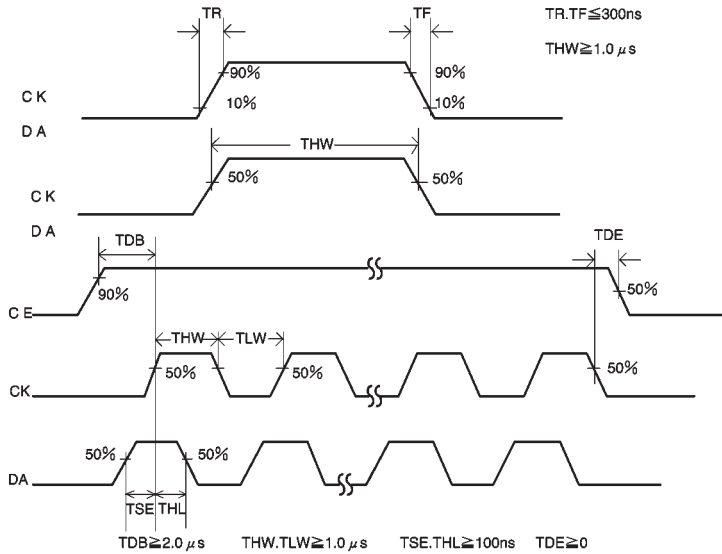

Input data format

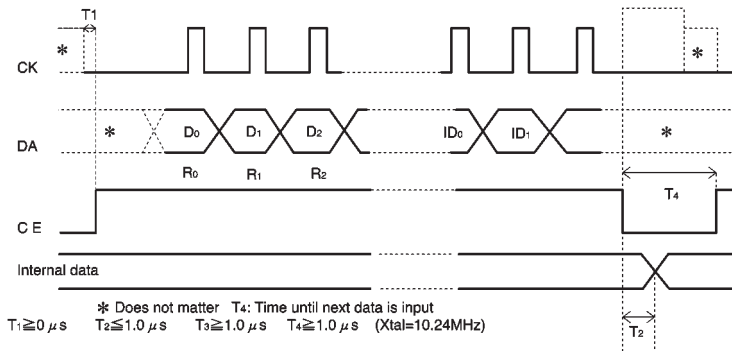

Programmable divider and control data input: TX side (ID₀ = 0, ID₁ = 0), RX side (ID₀ = 1, ID₁ = 0)

LSB ← Input from D₀

D ₀	D ₁	D ₂	D ₃	D ₄	D ₅	D ₆	D ₇	D ₈	D ₉	D ₁₀	D ₁₁	D ₁₂	D ₁₃	D ₁₄	D ₁₅
				P-T	TON	OFF	PS	T ₀	T ₁	ID ₀	ID ₁				
				(P-R	TON	OFF	PS	T ₀	T ₁)						

MSB

Reference frequency divider data input: TX side (ID₀ = 0, ID₁ = 1), RX side (ID₀ = 1, ID₁ = 1)

R ₀	R ₁	R ₂	R ₃	R ₄	R ₅	R ₆	R ₇	R ₈	R ₉	R ₁₀	R ₁₁	R ₁₂	R ₁₃	PL	PH
				*	*	LD ₀	LD ₁	*	*	ID ₀	ID ₁				

MSB

* Does not matter (LD₀ and LD₁₀ are valid on TX side only)

Description of data

(1) Programmable divider data: D₀ ~ D₁₅

D ₀	D ₁	D ₂	D ₃	D ₄	D ₅	D ₆	D ₇	D ₈	D ₉	D ₁₀	D ₁₁	D ₁₂	D ₁₃	D ₁₄	D ₁₅
Example: For a transmission frequency of 46.610MHz and a reference frequency of 5.00 kHz															
No. of divisions: 46.610 ÷ 5.00 kHz = 9322 (D) = 246A (H)															
0	1	0	1	0	1	1	0	0	0	1	0	0	1	0	0
A				6				4				2			

(2) Reference frequency data: R₀ ~ R₁₃

R ₀	R ₁	R ₂	R ₃	R ₄	R ₅	R ₆	R ₇	R ₈	R ₉	R ₁₀	R ₁₁	R ₁₂	R ₁₃
Example: When XTAL = 10.24 MHz and reference frequency is 5.00 kHz													
No. of divisions: 10.24 MHz ÷ 5.00 kHz = 2048 (D) = 800 (H)													
0	0	0	0	0	0	0	0	0	0	0	1	0	0
0				0				8				0	

(3) Output port control data : P-T (P-R) TON (RON)

1 : Open drain output ON (LO)

0 : Open drain output OFF (HI)

(4) OFF transmission side (reception side) : Operation stopped

F - T (F - R) pull-down : TPD (RPD) high-impedance, LD = OFF

(5) PS

Programmable device change : No. of divisions = 3 ~ 4095

D ₀	D ₁	D ₂	D ₃	D ₄	D ₅	D ₆	D ₇	D ₈	D ₉	D ₁₀	D ₁₁	D ₁₂	D ₁₃	D ₁₄	D ₁₅
*	*	*	*	LSB											MSB
DONT CARE															

- (6) PL, PH, and PD pin control
 - 0 0 : PLL operation
 - 1 0 : Forced LO state
 - 0 1 : Forced HI state
 - 1 1 : Forced LO state
- (7) LD₀, LD₁, LD pin control (valid only on TX side)
 - 0 0 : ON when unlocked (LO)
 - 0 1 : Air pulse output
 - 1 0 : Forced ON state (LO)
 - 1 1 : Forced OFF state (HI)
- (8) Input (00) to test T₀ and T₁.

●Application example

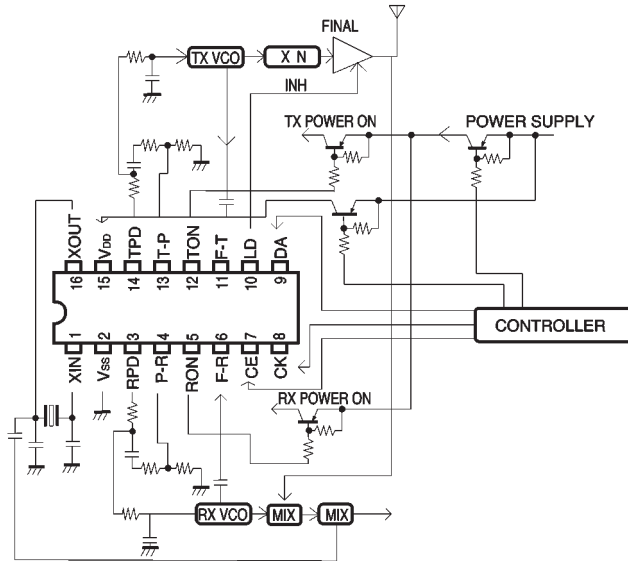

※: Immediately after the power supply is turned on, the various pins remain unstable until data is input.

Fig. 1

●Electrical characteristic curves

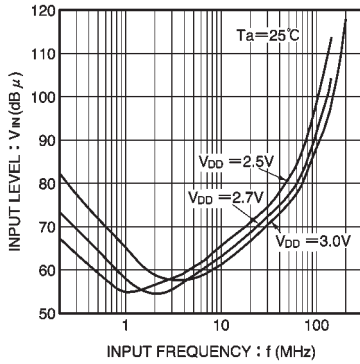

Fig. 2 Input frequency vs. input level

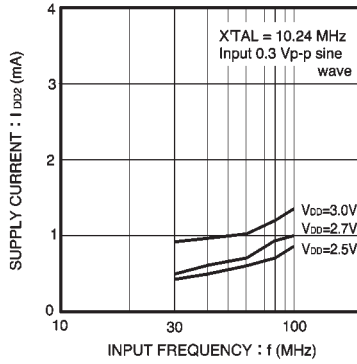

Fig. 3 Input frequency vs. supply current (for single operation)

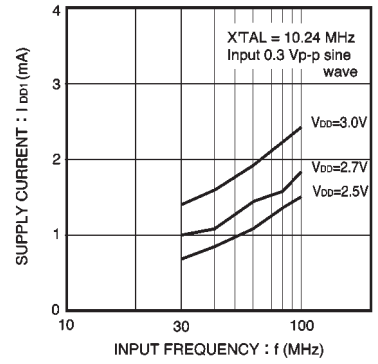
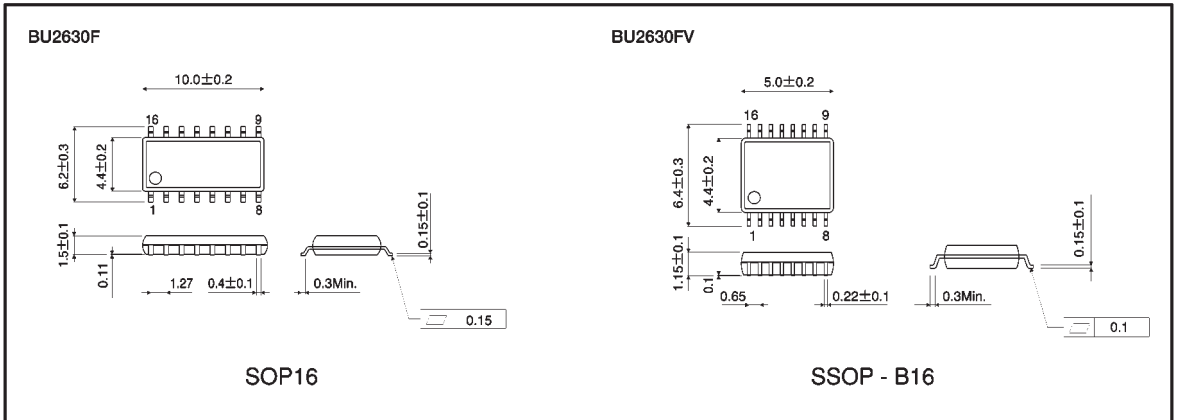

Fig. 4 Input frequency vs. supply current (for dual operation)

●External dimensions (Units: mm)



This datasheet has been downloaded from:

www.DatasheetCatalog.com

Datasheets for electronic components.



LittleDiode supplies new, hard to find or obsolete electronic components and semiconductors all over the world.

With over two million different components listed you are sure to find the part you need.

Feel free to visit us today at our online store:

LittleDiode.com

Looking forward to providing you with the best possible service.