

COP413C/COP413CH/COP313C/COP313CH Single-Chip CMOS Microcontrollers

General Description

The COP413C, COP413CH, COP313C, and COP313CH fully static, single-chip CMOS microcontrollers are members of the COPSTM family, fabricated using double-poly, silicon-gate CMOS technology. These controller-oriented processors are complete microcomputers containing all system timing, internal logic, ROM, RAM, and I/O necessary to implement dedicated control functions in a variety of applications. Features include single supply operation, with an instruction set, internal architecture, and I/O scheme designed to facilitate keyboard input, display output, and BCD data manipulation. The COP413CH is identical to the COP413C except for operating voltage and frequency. They are an appropriate choice for use in numerous human interface control environments. Standard test procedures and reliable high-density fabrication techniques provide a customized controller-oriented processor at a low end-product cost.

The COP313C/COP313CH is the extended temperature range version of the COP413C/COP413CH.

For emulation use the ROMless COP404C.

Features

- Lowest power dissipation (40 μ W typical)
- Low cost
- Power-saving HALT Mode
- Powerful instruction set
- 512 x 8 ROM, 32 x 4 RAM
- 15 I/O lines
- Two-level subroutine stack
- DC to 4 μ s instruction time
- Single supply operation (3V to 5.5V)
- General purpose and TRI-STATE® outputs
- Internal binary counter register with MICROWIRE™ compatible serial I/O
- Software/hardware compatible with other members of the COP400 family
- Extended temperature (-40°C to $+85^{\circ}\text{C}$) devices available

Block Diagram

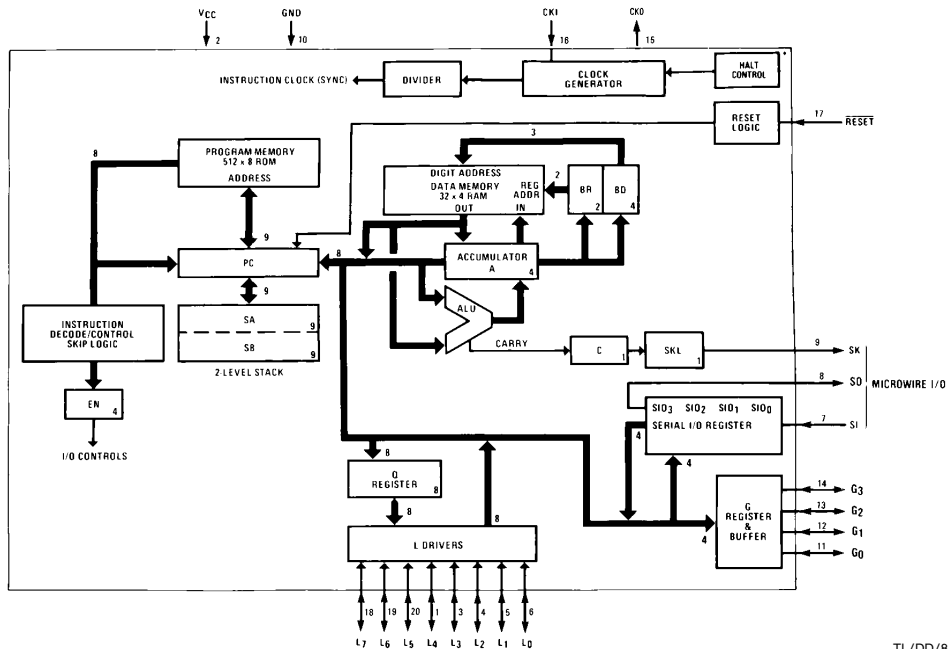

TL/DD/8537-1

FIGURE 1. COP413C/413CH

TRI-STATE® is a registered trademark of National Semiconductor Corp.
COPSTM, MICROWIRE™ and STARPLEX™ are trademarks of National Semiconductor Corp.

COP413C/COP413CH/COP313C/COP313CH Single-Chip CMOS Microcontrollers

COP413C/COP413CH

Absolute Maximum Ratings

If Military/Aerospace specified devices are required, please contact the National Semiconductor Sales Office/Distributors for availability and specifications.

Supply Voltage	6V
Voltage at Any Pin	-0.3V to $V_{CC} + 0.3V$
Total Allowable Source Current	25 mA
Total Allowable Sink Current	25 mA

Operating Temperature Range	0°C to +70°C
Storage Temperature Range	-65°C to +150°C

Note: Absolute maximum ratings indicate limits beyond which damage to the device may occur. DC and AC electrical specifications are not ensured when operating the device at absolute maximum ratings.

DC Electrical Characteristics $0^{\circ}\text{C} \leq T_A \leq +70^{\circ}\text{C}$ unless otherwise specified

Parameter	Conditions	COP413C		COP413CH		Units
		Min	Max	Min	Max	
Operating Voltage		3.0	5.5	4.5	5.5	V
Power Supply Ripple (Notes 4, 5)			0.1 V_{CC}		0.1 V_{CC}	V
Supply Current (Note 1)	$V_{CC} = 5.0V, t_c = \text{Min}$ $V_{CC} = 3.0V, t_c = \text{Min}$ (t_c is inst. cycle)		500 300		2000	μA μA
HALT Mode Current (Note 2)	$V_{CC} = 5.0V, F_I = 0 \text{ kHz}$ $V_{CC} = 3.0V, F_I = 0 \text{ kHz}$		30 10		30	μA μA
Input Voltage Levels						
$\overline{\text{RESET}}$, CKI						
Logic High		0.9 V_{CC}		0.9 V_{CC}		V
Logic Low			0.1 V_{CC}		0.1 V_{CC}	V
All Other Inputs						
Logic High		0.7 V_{CC}		0.7 V_{CC}		V
Logic Low			0.2 V_{CC}		0.2 V_{CC}	V
$\overline{\text{RESET}}$, SI Input Leakage		-1	+1	-1	+1	μA
Input Capacitance (Notes 5, 6)			7		7	pF
Output Voltage Levels						
(SO, SK, L Port)						
Logic High	$I_{OH} = -10 \mu\text{A}$	$V_{CC} - 0.2$		$V_{CC} - 0.2$		V
Logic Low	$I_{OL} = 10 \mu\text{A}$		0.2		0.2	V
Output Current Levels						
Sink (Note 3)	$V_{CC} = \text{Min}, V_{OUT} = V_{CC}$	0.2		1.2		mA
Source (SO, SK, L Port)	$V_{CC} = \text{Min}, V_{OUT} = 0V$	-0.1		-0.5		mA
Source (G Port)	$V_{CC} = \text{Min}, V_{OUT} = 0V$	-8	-150	-30	-330	μA
Allowable Sink/Source Current Per Pin (Note 3)			5		5	mA
TRI-STATE Leakage Current		-2	+2	-2	+2	μA

COP413C/COP413CH

AC Electrical Characteristics $0^{\circ}\text{C} \leq T_A \leq 70^{\circ}\text{C}$ unless otherwise specified

Parameter	Conditions	COP413C		COP413CH		Units
		Min	Max	Min	Max	
Instruction Cycle Time		16	DC	4	DC	μs
Operating CKI Frequency	$\div 8$ Mode	DC	500	DC	2000	kHz
Instruction Cycle Time RC Oscillator $\div 4$	R = $30\text{k} \pm 5\%$, $V_{\text{CC}} = 5\text{V}$ C = $82\text{ pF} \pm 5\%$			8	16	μs
Instruction Cycle Time RC Oscillator $\div 4$ (Note 6)	R = $56\text{k} \pm 5\%$, $V_{\text{CC}} = 5\text{V}$ C = $100\text{ pF} \pm 5\%$	16	32	16	32	μs
Duty Cycle (Note 5)	$F_i = \text{Max freq ext clk}$	40	60	40	60	%
Rise Time (Note 5)	$F_i = \text{Max freq ext clk}$		60		60	ns
Fall Time (Note 5)	$F_i = \text{Max freq ext clk}$		40		40	ns
Inputs (See <i>Figure 3</i>) t_{SETUP}	G Inputs SI Input L Inputs	$t_c/4 + 2.8$ 1.2 6.8		$t_c/4 + 0.7$ 0.3 1.7		μs μs μs
t_{HOLD}		1.0		0.25		μs
Output Propagation Delay t_{PD1} , t_{PD0}	$V_{\text{OUT}} = 1.5$, $C_L = 100\text{ pF}$ $R_L = 5\text{k}$		4.0		1.0	μs

Note 1: Supply current is measured after running for 2000 cycle times with a square-wave clock on CKI, CKO open, and all other pins pulled to V_{CC} with 5k resistors.

Note 2: The Halt mode will stop CKI from oscillating.

Note 3: SO output sink current must be limited to keep V_{OL} less than $0.2 V_{\text{CC}}$ when part is running in order to prevent entering test mode.

Note 4: Voltage change must be less than 0.5V in a 1 ms period.

Note 5: This parameter is only sampled and not 100% tested.

Note 6: Variation due to the device included.

COP313C/COP313CH

Absolute Maximum Ratings

If Military/Aerospace specified devices are required, please contact the National Semiconductor Sales Office/Distributors for availability and specifications.

Supply Voltage 6V
 Voltage at Any Pin $-0.3V$ to $V_{CC} + 0.3V$
 Total Allowable Source Current 25 mA

Total Allowable Sink Current 25 mA
 Operating Temperature Range $-40^{\circ}C$ to $+85^{\circ}C$
 Storage Temperature Range $-65^{\circ}C$ to $+150^{\circ}C$

Note: Absolute maximum ratings indicate limits beyond which damage to the device may occur. DC and AC electrical specifications are not ensured when operating the device at absolute maximum ratings.

DC Electrical Characteristics $-40^{\circ}C \leq T_A \leq +85^{\circ}C$ unless otherwise specified

Parameter	Conditions	COP313C		COP313CH		Units
		Min	Max	Min	Max	
Operating Voltage		3.0	5.5	4.5	5.5	V
Power Supply Ripple (Notes 4, 5)			$0.1 V_{CC}$		$0.1 V_{CC}$	V
Supply Current (Note 1)	$V_{CC} = 5.0V, t_c = \text{Min}$ $V_{CC} = 3.0V, t_c = \text{Min}$ (t_c is inst. cycle)		600 360		2500	μA μA
Halt Mode Current (Note 2)	$V_{CC} = 5.0V, Fi = 0 \text{ kHz}$ $V_{CC} = 3.0V, Fi = 0 \text{ kHz}$		50 20		50	μA μA
Input Voltage Levels RESET, CKI Logic High Logic Low All Other Inputs Logic High Logic Low		0.9 V_{CC} 0.7 V_{CC}	 0.1 V_{CC} 0.2 V_{CC}	0.9 V_{CC} 0.7 V_{CC}	0.1 V_{CC} 0.2 V_{CC}	V V V V
$\overline{\text{RESET}}$, SI Input Leakage		-2	+2	-2	+2	μA
Input Capacitance (Notes 5, 6)			7		7	pF
Output Voltage Levels (SO, SK, L Port) Logic High Logic Low	$I_{OH} = -10 \mu A$ $I_{OL} = 10 \mu A$	$V_{CC} - 0.2$	0.2	$V_{CC} - 0.2$	0.2	V V
Output Current Levels Sink (Note 3) Source (SO, SK, L Port) Source (G Port)	$V_{CC} = \text{Min}, V_{OUT} = V_{CC}$ $V_{CC} = \text{Min}, V_{OUT} = 0V$ $V_{CC} = \text{Min}, V_{OUT} = 0V$	0.2 -0.1 -8	 -200	1.2 -0.5 -30	 -440	mA mA μA
Allowable Sink/Source Current Per Pin (Note 3)			5		5	mA
TRI-STATE Leakage Current (Note 3)		-4	+4	-4	+4	μA

COP313C/COP313CH

AC Electrical Characteristics $-40^{\circ}\text{C} \leq T_A \leq +85^{\circ}\text{C}$ unless otherwise specified

Parameter	Conditions	COP313C		COP313CH		Units
		Min	Max	Min	Max	
Instruction Cycle Time		16	DC	4	DC	μs
Operating CKI Frequency	$\div 8$ Mode	DC	500	DC	2000	kHz
Instruction Cycle Time RC Oscillator $\div 4$	R = $30\text{k} \pm 5\%$, $V_{\text{CC}} = 5\text{V}$ C = $82\text{pF} \pm 5\%$			8	16	μs
Instruction Cycle Time RC Oscillator $\div 4$ (Note 6)	R = $56\text{k} \pm 5\%$, $V_{\text{CC}} = 5\text{V}$ C = $100\text{pF} \pm 5\%$	16	32	16	32	μs
Duty Cycle (Note 5)	Fi = Max Freq Ext Clk	40	60	40	60	%
Rise Time (Note 5)	Fi = Max Freq Ext Clk		60		60	ns
Fall Time (Note 5)	Fi = Max Freq Ext Clk		40		40	ns
Inputs (See Figure 3) t_{SETUP}	G Inputs	$t_{\text{c}}/4 + 2.8$		$t_{\text{c}}/4 + 0.7$		μs
	SI Input	1.2		0.3		μs
	L Inputs	6.8		1.7		μs
	t_{HOLD}	1.0		0.25		μs
Output Propagation Delay t_{PD1} , t_{PD0}	$V_{\text{OUT}} = 1.5\text{V}$, $C_{\text{L}} = 100\text{pF}$ $R_{\text{L}} = 5\text{k}$		4.0		1.0	μs

Note 1: Supply current is measured after running for 2000 cycle times with a square-wave clock on CKI, CKO open, and all other pins pulled up to V_{CC} with 5k resistors. See current drain equation on page 13.

Note 2: The Halt mode will stop CKI from oscillating.

Note 3: SO output sink current must be limited to keep V_{OL} less than $0.2 V_{\text{CC}}$ when part is running in order to prevent entering test mode.

Note 4: Voltage change must be less than 0.5V in a 1 ms period.

Note 5: This parameter is only sampled and not 100% tested.

Note 6: Variation due to the device included.

Connection Diagram

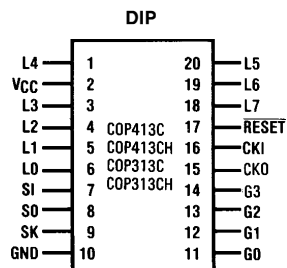

Top View

TL/DD/8537-2

Pin Descriptions

Pin	Description
L7-L0	8-bit bidirectional I/O port with TRI-STATE
G3-G0	4-bit bidirectional I/O port
SI	Serial input (or counter input)
SO	Serial output (or general purpose output)
SK	Logic-controlled clock (or general purpose output)
CKI	System oscillator input
CKO	Crystal oscillator output, or NC
RESET	System reset input
VCC	System power supply
GND	System Ground

FIGURE 2

Order Number COP313C-XXX/D, COP313CH-XXX/D,
COP413C-XXX/D or COP413CH-XXX/D
See NS Hermetic Package Number D20A

Order Number COP313C-XXX/N, COP313CH-XXX/N,
COP413C-XXX/N or COP413CH-XXX/N
See NS Molded Package Number N20A

Order Number COP313C-XXX/WM or
COP413C-XXX/WM
See NS Small Outline Package Number M20B

Timing Waveform

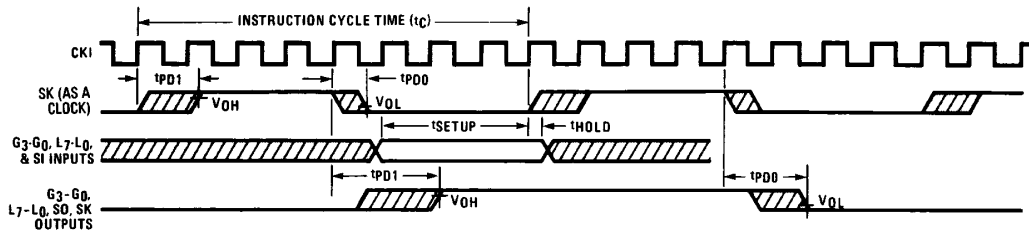

FIGURE 3. Input/Output Timing Diagrams (Divide-by-8 Mode)

TL/DD/8537-3

Development Support

The MOLE (Microcontroller On Line Emulator) is a low cost development system and real time emulator for COPS' products. They also include TMP, 8050 and the new 16 bit HPC microcontroller family. The MOLE provides effective support for the development of both software and hardware in the user's application.

The purpose of the MOLE is to provide a tool to write and assemble code, emulate code for the target microcontroller and assist in debugging of the system.

The MOLE can be connected to various hosts, IBM PC, STARPLEX™, Kaypro, Apple and Intel systems, via RS-232 port. This link facilitates the up loading/down loading of code, supports host assembly and mass storage.

The MOLE consists of three parts; brain, personality and optional host software.

The brain board is the computing engine of the system. It is a self-contained computer with its own firmware which provides for all system operation, emulation control, communication, from programming and diagnostic operation. It has three serial ports which can be connected to a terminal, host system, printer, modem or to other MOLE's in a multi-MOLE environment.

The personality board contains the necessary hardware and firmware needed to emulate the target microcontroller. The emulation cable which replaces the target controller attaches to this board. The software contains a cross assembler and a communications program for up loading and down loading code from the MOLE.

MOLE Ordering Information

P/N	Description
MOLE-BRAIN	MOLE Computer Board
MOLE-COPS-PB1	COPS Personality Board
MOLE-XXX-YYY	Optional Software

Where XXX = COPS
 YYY = Host System, IBM, Apple,
 KAY (Kaypro), CP/M

Functional Description

To ease reading of this description, only COP413C is referenced; however, all such references apply equally to COP413CH, COP313C, and COP313CH.

A block diagram of the COP413C is given in *Figure 1*. Data paths are illustrated in simplified form to depict how the various logic elements communicate with each other in implementing the instruction set of the device. Positive logic is used. When a bit is set, it is a logic "1"; when a bit is reset, it is a logic "0".

PROGRAM MEMORY

Program memory consists of a 512-byte ROM. As can be seen by an examination of the COP413C instruction set, these words may be program instructions, program data, or ROM addressing data. Because of the special characteristics associated with the JP, JSRP, JID, and LQID instructions, ROM must often be thought of as being organized into 8 pages of 64 words (bytes) each.

ROM ADDRESSING

ROM addressing is accomplished by a 9-bit PC register. Its binary value selects one of the 512 8-bit words contained in ROM. A new address is loaded into the PC register during each instruction cycle. Unless the instruction is a transfer of control instruction, the PC register is loaded with the next sequential 9-bit binary count value. Two levels of subroutine nesting are implemented by two 9-bit subroutine save registers, SA and SB.

ROM instruction words are fetched, decoded, and executed by the instruction decode, control and skip logic circuitry.

DATA MEMORY

Data Memory consists of a 128-bit RAM, organized as four data registers of 8×4 -bit digits. RAM addressing is implemented by a 6-bit B register whose upper two bits (Br) selects one of four data registers and lower three bits of the 4-bit Bd select one of eight 4-bit digits in the selected data register. While the 4-bit contents of the selected RAM digit (M) are usually loaded into or from, or exchanged with, the A register (accumulator), they may also be loaded into the Q latches or loaded from the L ports. RAM addressing may also be performed directly by the XAD 3, 15 instruction.

The most significant bit of Bd is not used to select a RAM digit. Hence, each physical digit of RAM may be selected by two different values of Bd as shown in *Figure 4*. The skip condition for XIS and XDS instructions will be true if Bd changes between 0 to 15, but *not* between 7 and 8 (see Table III).

INTERNAL LOGIC

The internal logic of the COP413C is designed to ensure fully static operation of the device.

The 4-bit A register (accumulator) is the source and destination register for most I/O, arithmetic, logic and data memory access operations. It can also be used to load the Bd portion of the B register, to load four bits of the 8-bit Q latch data and to perform data exchanges with the SIO register.

The 4-bit adder performs the arithmetic and logic functions of the COP413C, storing its results in A. It also outputs the carry information to a 1-bit carry register, most often employed to indicate arithmetic overflow. The C register, in conjunction with the XAS instruction and the EN register, also serves to control the SK output. C can be outputted directly to SK or can enable SK to be a sync clock each instruction cycle time. (See XAS instruction and EN register description below.)

The G register contents are outputs to four general purpose bidirectional I/O ports.

The Q register is an internal, latched, 8-bit register, used to hold data loaded from RAM and A, as well as 8-bit data from ROM. Its contents are output to the L I/O ports when the L drivers are enabled under program control. (See LEI instruction.)

The eight L drivers, when enabled, output the contents of latched Q data to the L I/O ports. Also, the contents of L may be read directly into A and RAM.

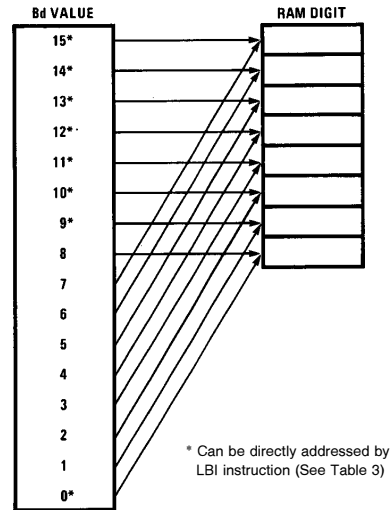

TL/DD/8537-4

FIGURE 4. RAM Digit Address to Physical RAM Digit Mapping

Functional Description (Continued)

The SIO register functions as a 4-bit serial-in/serial-out shift register or as a binary counter, depending upon the contents of the EN register. (See EN register description below.) Its contents can be exchanged with A, allowing it to input or output a continuous serial data stream. With SIO functioning as a serial-in/serial-out shift register and SK as a sync clock, the COP413C is MICROWIRE compatible.

The XAS instruction copies C into the SKL latch. In the counter mode, SK is the output of SKL; in the shift register mode, SK is a sync clock, inhibited when SKL is a logic "0".

The EN register is an internal 4-bit register loaded under program control by the LEI instruction. The state of each bit of this register selects or deselects the particular feature associated with each bit of the EN register (EN3–EN0).

1. The least significant bit of the enable register, EN0, selects the SIO register as either a 4-bit shift register or as a 4-bit binary counter. With EN0 set, SIO is an asynchronous binary counter, *decrementing* its value by one upon each low-going pulse ("1" to "0") occurring on the SI input. Each pulse must be at least two instruction cycles wide. SK outputs the value of SKL. The SO output is equal to the value of EN3. With EN0 reset, SIO is a serial shift register, shifting left each instruction cycle time. The data present at SI is shifted into the least significant bit of SIO. SO can be enabled to output the most significant bit of SIO each instruction cycle time. (See 4, below.) The SK output becomes a logic-controlled clock.
2. EN 1 is not used, it has no effect on the COP413C.
3. With EN2 set, the L drivers are enabled to output the data in Q to the L I/O ports. Resetting EN2 disables the L drivers, placing the L I/O ports in a high impedance input state.
4. EN3, in conjunction with EN0, affects the SO output. With EN0 set (binary counter option selected), SO will output the value loaded into EN3. With EN0 reset (serial shift

register option selected), setting EN3 enables SO as the output of the SIO shift register, outputting serial shifted data each instruction time. Resetting EN3 with the serial shift register option selected, disables SO as the shift register output; data continues to be shifted through SIO and can be exchanged with A via an XAS instruction but SO remains reset to "0".

INITIALIZATION

The external RC network shown in *Figure 5* must be connected to the RESET pin. The RESET pin is configured as a Schmitt trigger input. If not used, it should be connected to V_{CC}. Initialization will occur whenever a logic "0" is applied to the RESET input, providing it stays low for at least three instruction cycle times.

Upon initialization, the PC register is cleared to 0 (ROM address 0) and the A, B, C, EN, and G registers are cleared. The SK output is enabled as a SYNC output, providing a pulse each instruction cycle time. Data memory (RAM) is not cleared upon initialization. The first instruction at address 0 must be a CLRA (clear A register).

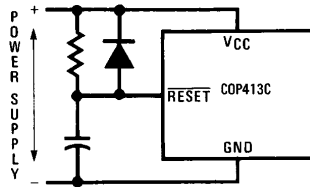

TL/DD/8537-5

$RC > 5 \times \text{Power Supply Rise Time}$
and $RC > 100 \times \text{CKI Period}$

FIGURE 5. Power-Up Clear Circuit

TABLE I. Enable Register Modes—Bits EN0 and EN3

EN0	EN3	SIO	SI	SO	SK
0	0	Shift Register	Input to Shift Register	0	If SKL = 1, SK = clock If SKL = 0, SK = 0
0	1	Shift Register	Input to Shift Register	Serial out	If SKL = 1, SK = clock If SKL = 0, SK = 0
1	0	Binary Counter	Input to Counter	0	SK = SKL
1	1	Binary Counter	Input to Counter	1	SK = SKL

Functional Description (Continued)

HALT MODE

The COP413C is a *fully static* circuit; therefore, the user may stop the system oscillator at any time to halt the chip. The chip may be halted by the HALT instruction. Once in the HALT mode, the internal circuitry does not receive any clock signal, and is therefore frozen in the exact state it was in when halted. All information is retained until continuing. The HALT mode is the minimum power dissipation state.

The HALT mode may be entered into by program control (HALT instruction) which forces CKO to a logic "1" state. The circuit can be awakened only by the RESET function.

POWER DISSIPATION

The lowest power drain is when the clock is stopped. As the frequency increases so does current. Current is also lower at lower operating voltages. Therefore, to minimize power consumption, the user should run at the lowest speed and voltage that his application will allow. The user should take care that all pins swing to full supply levels to ensure that outputs are not loaded down and that inputs are not at some intermediate level which may draw current. Any input with a slow rise or fall time will draw additional current. A crystal- or resonator-generated clock will draw more than a square-wave input. An RC oscillator will draw even more current since the input is a slow rising signal.

If using an external squarewave oscillator, the following equation can be used to calculate the COP413C current drain.

$$I_c = I_q + (V \times 20 \times F_i) + (V \times 1280 \times F_i / D_v)$$

where I_c = chip current drain in microamps

I_q = quiescent leakage current (from curve)

F_i = CKI frequency in megahertz

V = chip V_{CC} in volts

D_v = divide by option selected

For example, at 5V V_{CC} and 400 kHz (divide by 8),

$$I_c = 30 + (5 \times 20 \times 0.4) + (5 \times 1280 \times 0.4/8)$$

$$I_c = 30 + 40 + 320 = 390 \mu A$$

OSCILLATOR OPTIONS

There are two options available that define the use of CKI and CKO.

- Crystal-Controlled Oscillator. CKI and CKO are connected to an external crystal. The instruction cycle time equals the crystal frequency divided by 8.
- RC-Controlled Oscillator. CKI is configured as a single pin RC-controlled Schmitt trigger oscillator. The instruction cycle equals the oscillation frequency divided by 4. CKO is NC.

The RC oscillator is not recommended in systems that require accurate timing or low current. The RC oscillator draws more current than an external oscillator (typically an additional 100 μA at 5V). However, when the part halts, it stops with CKI high and the halt current is at the minimum.

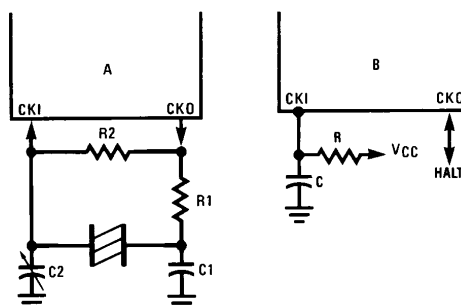

TL/DD/8537-6

FIGURE 6. COP413C Oscillator

Crystal or Resonator					RC-Controlled Oscillator			
Crystal Value	R1	R2	Component Value C1 pF	C2 pF	R	C	Cycle Time	V_{CC}
32 kHz	220k	20M	30	5-36	15k	82 pF	4-9 μs	$\geq 4.5V$ COP413CH Only
455 kHz	5k	10M	80	40	30k	82 pF	8-16 μs	$\geq 4.5V$ COP413CH Only
2.000 MHz	2k	1M	30	6-36	47k	100 pF	16-32 μs	3.0 to 4.5V COP413C Only
					56k	100 pF	16-32 μs	$\geq 4.5V$

Note: $15k \leq R \leq 150k$,
 $50 pF \leq C \leq 150 pF$

Functional Description (Continued)

I/O CONFIGURATIONS

COP413C outputs have the following configurations, illustrated in *Figure 7*:

- Standard SO, SK Output. A CMOS push-pull buffer with an N-channel device to ground in conjunction with a P-channel device to V_{CC} , compatible with CMOS and LSTTL.
- Low Current G Output. This is the same configuration as (a) above except that the sourcing current is much less.
- Standard TRI-STATE L Output. L output is a CMOS output buffer similar to (a) which may be disabled by program control.

The SI and $\overline{\text{RESET}}$ inputs are Hi-Z inputs (*Figure 7d*).

When using the G I/O port as an input, set the output register to a logic "1" level. The P-channel device will act as a pull-up load. When using the L I/O port as an input, disable the L drivers with the LEI instruction. The drivers are then in TRI-STATE mode and can be driven externally.

All output drivers use one or more of three common devices numbered 1 to 3. Minimum and maximum current (I_{OUT} and V_{OUT}) curves are given in *Figure 8* for each of these devices to allow the designer to effectively use these I/O configurations.

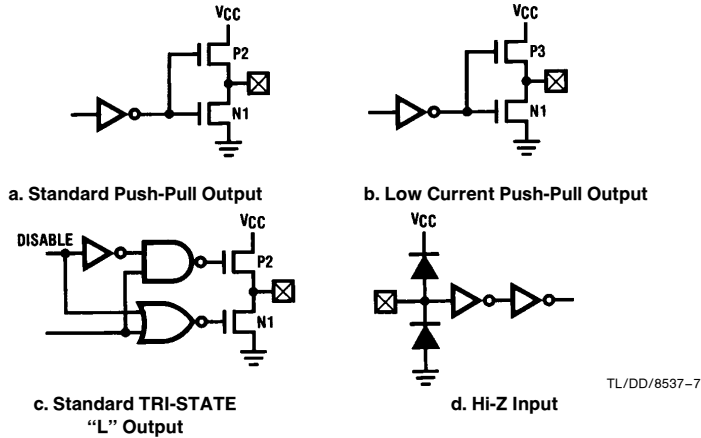

FIGURE 7. I/O Configurations

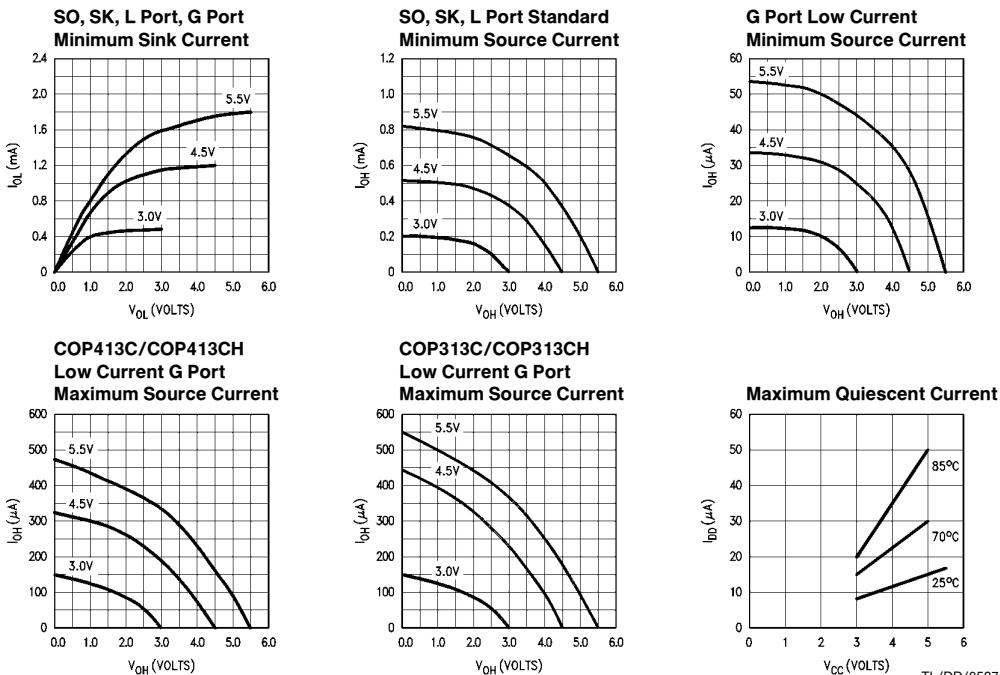

FIGURE 8

COP413C Instruction Set

Table II is a symbol table providing internal architecture, instruction operand and operational symbols used in the instruction set table.

Table III provides the mnemonic, operand, machine code, data flow, skip conditions and description associated with each instruction in the COP413C instruction set.

TABLE II. COP413C Instruction Set Table Symbols

Symbol	Definition	Symbol	Definition
INTERNAL ARCHITECTURE SYMBOLS		INSTRUCTION OPERAND SYMBOLS	
A	4-bit Accumulator	d	4-bit Operand Field, 0–15 binary (RAM Digit Select)
B	6-bit RAM Address Register	r	2-bit Operand Field, 0–3 binary (RAM Register Select)
Br	Upper 2 bits of B (register address)	a	9-bit Operand Field, 0–511 binary (ROM Address)
Bd	Lower 4 bits of B (digit address)	y	4-bit Operand Field, 0–15 binary (Immediate Data)
C	1-bit Carry Register	RAM(s)	Contents of RAM location addressed by s
EN	4-bit Enable Register	ROM(t)	Contents of ROM location addressed by t
G	4-bit Register to latch data for G I/O Port		
L	8-bit TRI-STATE I/O Port	OPERATIONAL SYMBOLS	
M	4-bit contents of RAM Memory pointed to by B Register	+	Plus
PC	9-bit ROM Address Register (program counter)	–	Minus
Q	8-bit Register to latch data for L I/O Port	→	Replaces
SA	9-bit Subroutine Save Register A	↔	Is exchanged with
SB	9-bit Subroutine Save Register B	=	Is equal to
SIO	4-bit Shift Register and Counter	\bar{A}	The one's complement of A
SK	Logic-Controlled Clock Output	\oplus	Exclusive-OR
		:	Range of values

TABLE III. COP413C Instruction Set

Mnemonic	Operand	Hex Code	Machine Language Code (Binary)	Data Flow	Skip Conditions	Description
ARITHMETIC INSTRUCTIONS						
ASC		30	<u>0011 0000</u>	$A + C + \text{RAM}(B) \rightarrow A$ Carry $\rightarrow C$	Carry	Add with Carry, Skip on Carry
ADD		31	<u>0011 0001</u>	$A + \text{RAM}(B) \rightarrow A$	None	Add RAM to A
AISC	y	5–	<u>0101 y</u>	$A + y \rightarrow A$	Carry	Add immediate, Skip on Carry ($y \neq 0$)
CLRA		00	<u>0000 0000</u>	$0 \rightarrow A$	None	Clear A
COMP		40	<u>0100 0000</u>	$\bar{A} \rightarrow A$	None	One's complement of A to A
NOP		44	<u>0100 0100</u>	None	None	No Operation
RC		32	<u>0011 0010</u>	"0" $\rightarrow C$	None	Reset C
SC		22	<u>0010 0010</u>	"1" $\rightarrow C$	None	Set C
XOR		02	<u>0000 0010</u>	$A \oplus \text{RAM}(B) \rightarrow A$	None	Exclusive-OR RAM with A

COP413C Instruction Set (Continued)

TABLE III. COP413C Instruction Set (Continued)

Mnemonic	Operand	Hex Code	Machine Language Code (Binary)	Data Flow	Skip Conditions	Description
TRANSFER OF CONTROL INSTRUCTIONS						
JID		FF	1111 1111	ROM(PC ₈ , A, M) → PC _{7:0}	None	Jump Indirect (Note 2)
JMP	a	6- -	0110 000 a ₈ a _{7:0}	a → PC	None	Jump
JP	a	-	1 a _{6:0} (pages 2, 3 only) or	a → PC _{6:0}	None	Jump within Page (Note 1)
			11 a _{5:0} (all other pages)	a → PC _{5:0}		
JSRP	a	-	10 a _{5:0}	PC + 1 → SA → SB 010 → PC _{8,6} a → PC _{5:0}	None	Jump to Subroutine Page (Note 2)
JSR	a	6- -	0110 100 a ₈ a _{7:0}	PC + 1 → SA → SB a → PC	None	Jump to Subroutine
RET		48	0100 1000	SB → SA → PC	None	Return from Subroutine
RETSK		49	0100 1001	SB → SA → PC	Always Skip on Return	Return from Subroutine then Skip
HALT		33	0011 0011		None	Halt processor
		38	0011 1000			
MEMORY REFERENCE INSTRUCTIONS						
CAMQ		33	0011 0011	A → Q _{7:4}	None	Copy A, RAM to Q
		3C	0011 1100	RAM(B) → Q _{3:0}		
CQMA		33	0011 0011	Q _{7:4} → RAM(B)	None	Copy Q to RAM, A
		2C	0010 1100	Q _{3:0} → A		
LD	r	-5	00 r 0101	RAM(B) → A Br ⊕ r → Br	None	Load RAM into A Exclusive-OR Br with r
LQID		BF	1011 1111	ROM(PC ₈ , A, M) → Q SA → SB	None	Load Q Indirect
RMB	0	4C	0100 1100	0 → RAM(B) ₀	None	Reset RAM Bit
	1	45	0100 0101	0 → RAM(B) ₁		
	2	42	0100 0010	0 → RAM(B) ₂		
	3	43	0100 0011	0 → RAM(B) ₃		
SMB	0	4D	0100 1101	1 → RAM(B) ₀	None	Set RAM Bit
	1	47	0100 0111	1 → RAM(B) ₁		
	2	46	0100 0110	1 → RAM(B) ₂		
	3	4B	0100 1011	1 → RAM(B) ₃		
STII	y	7-	0111 y	y → RAM(B) Bd + 1 → Bd	None	Store Memory Immediate and Increment Bd
X	r	-6	00 r 0110	RAM(B) ↔ A Br ⊕ r → Br	None	Exchange RAM with A, Exclusive-OR Br with r
XAD	3,15	23 BF	0010 0011 1011 1111	RAM(3,15) ↔ A	None	Exchange A with RAM (3,15)

COP413C Instruction Set (Continued)

TABLE III. COP413C Instruction Set (Continued)

Mnemonic	Operand	Hex Code	Machine Language Code (Binary)	Data Flow	Skip Conditions	Description
MEMORY REFERENCE INSTRUCTIONS (Continued)						
XDS	r	-7	00 r 0111	RAM(B) \leftrightarrow A Bd - 1 \rightarrow Bd Br \oplus r \rightarrow Br	Bd decrements past 0	Exchange RAM with A and Decrement Bd Exclusive-OR Br with r
XIS	r	-4	00 r 0100	RAM(B) \leftrightarrow A Bd + 1 \rightarrow Bd Br \oplus r \rightarrow Br	Bd increments past 15	Exchange RAM with A and Increment Bd Exclusive-OR Br with r
REGISTER REFERENCE INSTRUCTIONS						
CAB		50	0101 0000	A \rightarrow Bd	None	Copy A to Bd
CBA		4E	0100 1110	Bd \rightarrow A	None	Copy Bd to A
LBI	r,d	-	00 r (d - 1) (d = 0,9:15)	r,d \rightarrow B	Skip until not a LBI	Load B Immediate with r,d
LEI	y	33 6-	0011 0011 0010 y	y \rightarrow EN	None	Load EN Immediate
TEST INSTRUCTIONS						
SKC		20	0010 0000		C = "1"	Skip if C is True
SKE		21	0010 0001		A = RAM(B)	Skip if A Equals RAM
SKGZ		33	0011 0011		G _{3:0} = 0	Skip if G is Zero (all 4 bits)
		21	0010 0001			
SKGBZ		33	0011 0011	1st byte 2nd byte	G ₀ = 0 G ₁ = 0 G ₂ = 0 G ₃ = 0	Skip if G Bit is Zero
	0	01	0000 0001			
	1	11	0001 0001			
	2	03	0000 0011			
SKMBZ		33	0011 0011	1st byte 2nd byte	RAM(B) ₀ = 0 RAM(B) ₁ = 0 RAM(B) ₂ = 0 RAM(B) ₃ = 0	Skip if RAM Bit is Zero
	0	01	0000 0001			
	1	11	0001 0001			
	2	03	0000 0011			
	3	13	0010 0011			
	3	13	0001 0011			
INPUT/OUTPUT INSTRUCTIONS						
ING		33	0011 0011	G \rightarrow A	None	Input G Ports to A
		2A	0010 1010			
INL		33	0011 0011	L _{7:4} \rightarrow RAM(B) L _{3:0} \rightarrow A	None	Input L Ports to RAM, A
		2E	0010 1110			
OMG		33	0011 0011	RAM(B) \rightarrow G	None	Output RAM to G Ports
		3A	0011 1010			
XAS		4F	0100 1111	A \leftrightarrow SIO, C \rightarrow SKL	None	Exchange A with SIO
<p>Note 1: The JP instruction allows a jump, while in subroutine pages 2 or 3, to any ROM location within the two-page boundary of pages 2 or 3. The JP instruction, otherwise, permits a jump to a ROM location within the current 64-word page. JP may not jump to the last word of a page.</p> <p>Note 2: A JSRP transfers program control to subroutine page 2 (0010 is loaded into the upper 4 bits of P). A JSRP may not be used when in pages 2 or 3. JSRP may not jump to the last word in page 2.</p>						

Description of Selected Instructions

The following information is provided to assist the user in understanding the operation of several unique instructions and to provide notes useful to programmers in writing COP413C programs.

XAS INSTRUCTION

XAS (Exchange A with SIO) exchanges the 4-bit contents of the accumulator with the 4-bit contents of the SIO register. The contents of SIO will contain serial-in/serial-out shift register or binary counter data, depending on the value of the EN register. An XAS instruction will also affect the SK output. (See Functional Description, EN Register.) If SIO is selected as a shift register, an XAS instruction must be performed once every four instruction cycle times to effect a continuous data stream.

JID INSTRUCTION

JID (Jump Indirect) is an indirect addressing instruction, transferring program control to a new ROM location pointed to indirectly by A and M. It loads the lower eight bits of the ROM address register PC with the contents of ROM addressed by the 9-bit word, PC_8 , A, M. PC_8 is not affected by this instruction.

Note: JID uses two instruction cycles if executed, one if skipped.

LQID INSTRUCTION

LQID (Load Q Indirect) loads the 8-bit Q register with the contents of ROM pointed to by the 9-bit word PC_8 , A, M. LQID can be used for table look-up or code conversion such as BCD to 7-segment. The LQID instruction "pushes" the stack ($PC + 1 \rightarrow SA \rightarrow SB$) and replaces the least significant eight bits of the PC as follows: $A \rightarrow PC_{7:4}$, $RAM(B) \rightarrow PC_{3:0}$, leaving PC_8 unchanged. The ROM data pointed to by the new address is fetched and loaded into the Q latches. Next, the stack is "popped" ($SB \rightarrow SA \rightarrow PC$), restoring the saved value of the PC to continue sequential program execution. Since LQID pushes $SA \rightarrow SB$, the previous contents of SB are lost.

Note: LQID uses two instruction cycles if executed, one if skipped.

INSTRUCTION SET NOTES

- a. The first word of a COP413C program (ROM address 0) must be a CLRA (Clear A) instruction.
- b. Although skipped instructions are not executed, one instruction cycle time is devoted to skipping each byte of the skipped instruction. Thus all program paths take the same number of cycle times whether instructions are skipped or executed (except JID and LQID).
- c. The ROM is organized into eight pages of 64 words each. The program counter is a 9-bit binary counter, and will count through page boundaries. If a JP, JSRP, JID, or LQID instruction is located in the last word of a page, the instruction operates as if it were in the next page. For example: A JP located in the last word of a page will jump to a location in the next page. Also, a LQID or JID located in the last word in page 3 or 7 will access data in the next group of four pages.

COPS Programming Manual

For detailed information on writing COPS programs, the COPS Programming Manual 424410284-001 provides an in-depth discussion of the COPS architecture, instruction set and general techniques of COPS programming. This manual is written with the programmer in mind.

OPTION LIST—OSCILLATOR SELECTION

The oscillator option selected must be sent in with the EPROM of ROM Code for masking into the COP413C. Select the appropriate option, make a photocopy of the table and send it with the EPROM.

COP413C/COP313C

- Option 1: Oscillator selection
- = 0 Ceramic Resonator input frequency divided by 8. CKO is oscillator output.
 - = 1 Single pin RC controlled oscillator divided by 4. CKO is no connection.

Note: The following option information is to be sent to National along with the EPROM.

Option 1: Value = ____ is Oscillator Selected.

Physical Dimensions inches (millimeters)

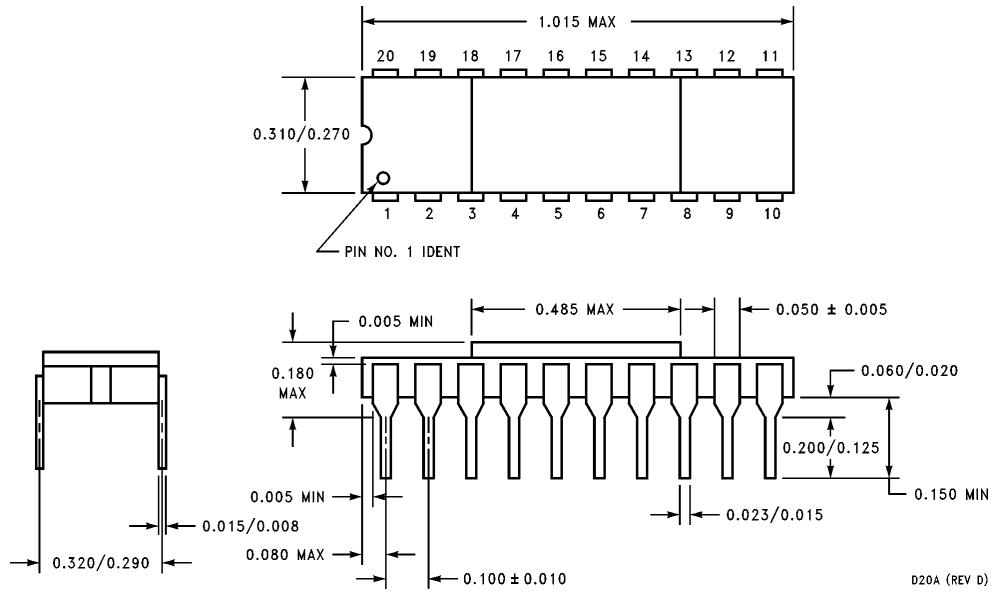

20-Lead Hermetic Dual-In-Line Package (D)
Order Number COP313C-XXX/D, COP313CH-XXX/D,
COP413C-XXX/D, COP413CH-XXX/D
NS Package Number D20A

D20A (REV D)

Physical Dimensions inches (millimeters) (Continued)

Lit. # 101975

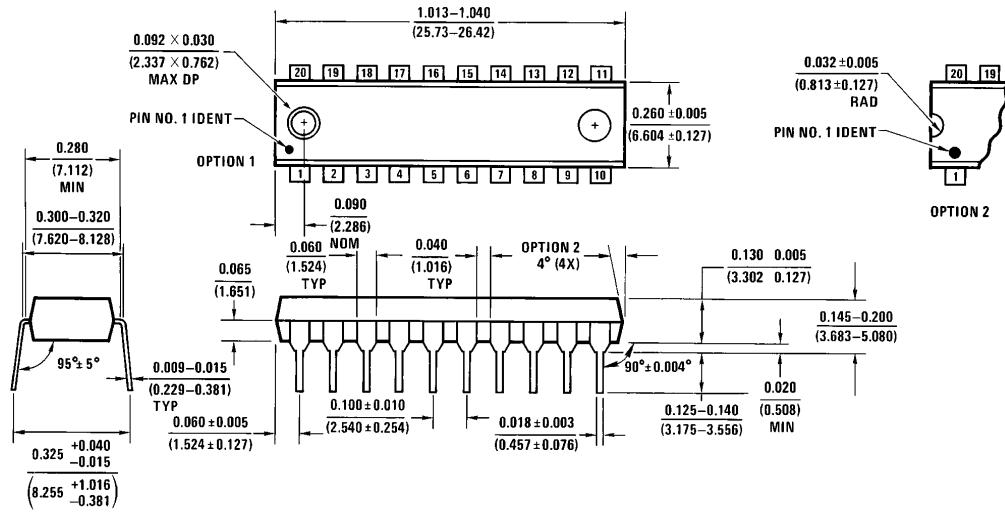

20-Lead Molded Dual-In-Line Package (N)
Order Number COP313C-XXX/N, COP313CH-XXX/N,
COP413C-XXX/N or COP413CH-XXX/N
NS Package Number N20A

N20A (REV G)

LIFE SUPPORT POLICY

NATIONAL'S PRODUCTS ARE NOT AUTHORIZED FOR USE AS CRITICAL COMPONENTS IN LIFE SUPPORT DEVICES OR SYSTEMS WITHOUT THE EXPRESS WRITTEN APPROVAL OF THE PRESIDENT OF NATIONAL SEMICONDUCTOR CORPORATION. As used herein:

1. Life support devices or systems are devices or systems which, (a) are intended for surgical implant into the body, or (b) support or sustain life, and whose failure to perform, when properly used in accordance with instructions for use provided in the labeling, can be reasonably expected to result in a significant injury to the user.
2. A critical component is any component of a life support device or system whose failure to perform can be reasonably expected to cause the failure of the life support device or system, or to affect its safety or effectiveness.



National Semiconductor Corporation
 1111 West Bardin Road
 Arlington, TX 76017
 Tel: 1(800) 272-9959
 Fax: 1(800) 737-7018

National Semiconductor Europe
 Fax: (+49) 0-180-530 85 86
 Email: cnjwge@tevm2.nsc.com
 Deutsch Tel: (+49) 0-180-530 85 85
 English Tel: (+49) 0-180-532 78 32
 Français Tel: (+49) 0-180-532 93 58
 Italiano Tel: (+49) 0-180-534 16 80

National Semiconductor Hong Kong Ltd.
 19th Floor, Straight Block,
 Ocean Centre, 5 Canton Rd.
 Tsimshatsui, Kowloon
 Hong Kong
 Tel: (852) 2737-1600
 Fax: (852) 2736-9960

National Semiconductor Japan Ltd.
 Tel: 81-043-299-2309
 Fax: 81-043-299-2408

National does not assume any responsibility for use of any circuitry described, no circuit patent licenses are implied and National reserves the right at any time without notice to change said circuitry and specifications.

National Semiconductor was acquired by Texas Instruments.

http://www.ti.com/corp/docs/investor_relations/pr_09_23_2011_national_semiconductor.html

This file is the datasheet for the following electronic components:

COP313C - <http://www.ti.com/product/cop313c?HQS=TI-null-null-dscatalog-df-pf-null-ww>

COP313CH - <http://www.ti.com/product/cop313ch?HQS=TI-null-null-dscatalog-df-pf-null-ww>

COP413C - <http://www.ti.com/product/cop413c?HQS=TI-null-null-dscatalog-df-pf-null-ww>

COP413CH - <http://www.ti.com/product/cop413ch?HQS=TI-null-null-dscatalog-df-pf-null-ww>



LittleDiode supplies new, hard to find or obsolete electronic components and semiconductors all over the world.

With over two million different components listed you are sure to find the part you need.

Feel free to visit us today at our online store:

LittleDiode.com

Looking forward to providing you with the best possible service.