

DAC1006/DAC1007/DAC1008 μ P Compatible, Double-Buffered D to A Converters

General Description

The DAC1006/7/8 are advanced CMOS/Si-Cr 10-, 9- and 8-bit accurate multiplying DACs which are designed to interface directly with the 8080, 8048, 8085, Z-80 and other popular microprocessors. These DACs appear as a memory location or an I/O port to the μ P and no interfacing logic is needed.

These devices, combined with an external amplifier and voltage reference, can be used as standard D/A converters; and they are very attractive for multiplying applications (such as digitally controlled gain blocks) since their linearity error is essentially independent of the voltage reference. They become equally attractive in audio signal processing equipment as audio gain controls or as programmable attenuators which marry high quality audio signal processing to digitally based systems under microprocessor control.

All of these DACs are double buffered. They can load all 10 bits or two 8-bit bytes and the data format is left justified. The analog section of these DACs is essentially the same as that of the DAC1020.

The DAC1006 series are the 10-bit members of a family of microprocessor-compatible DAC's (MICRO-DAC™'s). For applications requiring other resolutions, the DAC0830 series (8 bits) and the DAC1208 and DAC1230 (12 bits) are available alternatives.

Part #	Accuracy (bits)	Pin	Description
DAC1006	10	20	For left-justified data
DAC1007	9		
DAC1008	8		

MICRO-DAC™ and BI-FET™ are trademarks of National Semiconductor Corp.

Features

- Uses easy to adjust END POINT specs, NOT BEST STRAIGHT LINE FIT
- Low power consumption
- Direct interface to all popular microprocessors
- Integrated thin film on CMOS structure
- Double-buffered, single-buffered or flow through digital data inputs
- Loads two 8-bit bytes or a single 10-bit word
- Logic inputs which meet TTL voltage level specs (1.4V logic threshold)
- Works with $\pm 10V$ reference—full 4-quadrant multiplication
- Operates STAND ALONE (without μ P) if desired
- Available in 0.3" standard 20-pin package
- Differential non-linearity selection available as special order

Key Specifications

- Output Current Settling Time 500 ns
- Resolution 10 bits
- Linearity 10, 9, and 8 bits (guaranteed over temp.)
- Gain Tempco -0.0003% of FS/ $^{\circ}$ C
- Low Power Dissipation 20 mW (including ladder)
- Single Power Supply 5 to 15 V_{DC}

DAC1006/DAC1007/DAC1008 μ P Compatible, Double-Buffered D to A Converters

Typical Application

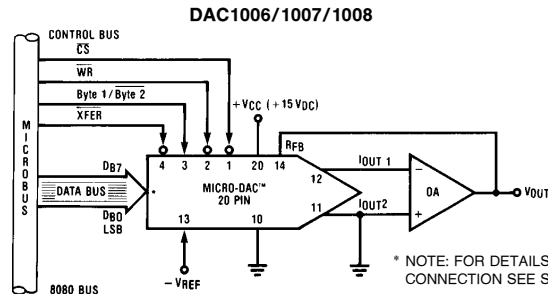

Absolute Maximum Ratings (Notes 1 & 2)

If Military/Aerospace specified devices are required, please contact the National Semiconductor Sales Office/Distributors for availability and specifications.

Supply Voltage (V_{CC})	17 V_{DC}
Voltage at Any Digital Input	V_{CC} to GND
Voltage at V_{REF} Input	$\pm 25V$
Storage Temperature Range	$-65^{\circ}C$ to $+150^{\circ}C$
Package Dissipation at $T_A = 25^{\circ}C$ (Note 3)	500 mW
DC Voltage Applied to I_{OUT1} or I_{OUT2} (Note 4)	-100 mV to V_{CC}

ESD Susceptibility (Note 11)	800V
Lead Temp. (Soldering, 10 seconds)	
Dual-In-Line Package (plastic)	260 $^{\circ}C$
Dual-In-Line Package (ceramic)	300 $^{\circ}C$

Operating Ratings (Note 1)

Temperature Range	$T_{MIN} \leq T_A \leq T_{MAX}$
Part numbers with "LCN" and "LCWN" suffix	0 $^{\circ}C$ to 70 $^{\circ}C$
Voltage at Any Digital Input	V_{CC} to GND

Electrical Characteristics

Tested at $V_{CC} = 4.75 V_{DC}$ and $15.75 V_{DC}$, $T_A = 25^{\circ}C$, $V_{REF} = 10.000 V_{DC}$ unless otherwise noted

Parameter	Conditions	See Note	$V_{CC} = 12V_{DC} \pm 5\%$ to $15V_{DC} \pm 5\%$			$V_{CC} = 5V_{DC} \pm 5\%$			Units
			Min.	Typ.	Max.	Min.	Typ.	Max.	
Resolution					10			10	bits
Linearity Error	Endpoint adjust only $T_{MIN} < T_A < T_{MAX}$ $-10V \leq V_{REF} \leq +10V$ DAC1006 DAC1007 DAC1008	4,7 6 5			0.05 0.1 0.2			0.05 0.1 0.2	% of FSR % of FSR % of FSR
Differential Nonlinearity	Endpoint adjust only $T_{MIN} < T_A < T_{MAX}$ $-10V \leq V_{REF} \leq +10V$ DAC1006 DAC1007 DAC1008	4,7 6 5			0.1 0.2 0.4			0.1 0.2 0.4	% of FSR % of FSR % of FSR
Monotonicity	$T_{MIN} < T_A < T_{MAX}$ $-10V \leq V_{REF} \leq +10V$ DAC1006 DAC1007 DAC1008	4,6 5	10 9 8			10 9 8			bits bits bits
Gain Error	Using internal R_{fb} $-10V \leq V_{REF} \leq +10V$	5	-1.0	± 0.3	1.0	-1.0	± 0.3	1.0	% of FS
Gain Error Tempco	$T_{MIN} < T_A < T_{MAX}$ Using internal R_{fb}	6 9		-0.0003	-0.001		-0.0006	-0.002	% of FS/ $^{\circ}C$
Power Supply Rejection	All digital inputs latched high $V_{CC} = 14.5V$ to $15.5V$ 11.5V to 12.5V 4.75V to 5.25V			0.003 0.004	0.008 0.010		0.033	0.10	% FSR/V % FSR/V % FSR/V
Reference Input Resistance			10	15	20	10	15	20	k Ω
Output Feedthrough Error	$V_{REF} = 20V_{p-p}$, $f = 100$ kHz All data inputs latched low			90			90		mV $_{p-p}$
Output Capacitance	I_{OUT1} I_{OUT2} All data inputs latched low I_{OUT1} I_{OUT2} All data inputs latched high			60 250 250 60		60 250 250 60			pF pF pF pF
Supply Current Drain	$T_{MIN} \leq T_A \leq T_{MAX}$	6		0.5	3.5		0.5	3.5	mA

Electrical Characteristics

Tested at $V_{CC} = 4.75 V_{DC}$ and $15.75 V_{DC}$, $T_A = 25^\circ C$, $V_{REF} = 10.000 V_{DC}$ unless otherwise noted (Continued)

Parameter	Conditions	See Note	$V_{CC} = 12V_{DC} \pm 5\%$ to $15V_{DC} \pm 5\%$			$V_{CC} = 5V_{DC} \pm 5\%$			Units
			Min.	Typ.	Max.	Min.	Typ.	Max.	
Output Leakage Current I_{OUT1} I_{OUT2}	$T_{MIN} \leq T_A \leq T_{MAX}$ All data inputs latched low	6							nA
		10			200			200	
	All data inputs latched high				200			200	nA
Digital Input Voltages	$T_{MIN} \leq T_A \leq T_{MAX}$ Low level LCN and LCWM suffix High level (all parts)	6			0.8, 0.8			0.7, 0.8	V_{DC} V_{DC}
			2.0			2.0			
Digital Input Currents	$T_{MIN} \leq T_A \leq T_{MAX}$ Digital inputs < 0.8V Digital inputs > 2.0V	6		-40 1.0	-150 +10		-40 1.0	-150 +10	μA_{DC} μA_{DC}
Current Settling Time	t_S $V_{IL} = 0V$, $V_{IH} = 5V$			500			500		ns
Write and \overline{XFER} Pulse Width	$V_{IL} = 0V$, $V_{IH} = 5V$, $T_A = 25^\circ C$, $T_{MIN} \leq T_A \leq T_{MAX}$	8	150	60		320	200		ns
		9	320	100		500	250		ns
Data Set Up Time	t_{DS} $V_{IL} = 0V$, $V_{IH} = 5V$, $T_A = 25^\circ C$, $T_{MIN} \leq T_A \leq T_{MAX}$	9	150	80		320	170		ns
			320	120		500	250		ns
Data Hold Time	t_{DH} $V_{IL} = 0V$, $V_{IH} = 5V$, $T_A = 25^\circ C$, $T_{MIN} \leq T_A \leq T_{MAX}$	9	200	100		320	220		ns
			250	120		500	320		ns
Control Set Up Time	t_{CS} $V_{IL} = 0V$, $V_{IH} = 5V$, $T_A = 25^\circ C$, $T_{MIN} \leq T_A \leq T_{MAX}$	9	150	60		320	180		ns
			320	100		500	260		ns
Control Hold Time	t_{CH} $V_{IL} = 0V$, $V_{IH} = 5V$, $T_A = 25^\circ C$, $T_{MIN} \leq T_A \leq T_{MAX}$	9	10	0		10	0		ns
			10	0		10	0		ns

Note 1: Absolute Maximum Ratings indicate limits beyond which damage to the device may occur. DC and AC electrical specifications do not apply when operating the device beyond its specified operating conditions.

Note 2: All voltages are measured with respect to GND, unless otherwise specified.

Note 3: This 500 mW specification applies for all packages. The low intrinsic power dissipation of this part (and the fact that there is no way to significantly modify the power dissipation) removes concern for heat sinking.

Note 4: For current switching applications, both I_{OUT1} and I_{OUT2} must go to ground or the "Virtual Ground" of an operational amplifier. The linearity error is degraded by approximately $V_{OS} \pm V_{REF}$. For example, if $V_{REF} = 10V$ then a 1 mV offset, V_{OS} , on I_{OUT1} or I_{OUT2} will introduce an additional 0.01% linearity error.

Note 5: Guaranteed at $V_{REF} = \pm 10 V_{DC}$ and $V_{REF} = \pm 1 V_{DC}$.

Note 6: $T_{MIN} = 0^\circ C$ and $T_{MAX} = 70^\circ C$ for "LCN" and "LCWM" suffix parts.

Note 7: The unit "FSR" stands for "Full Scale Range." "Linearity Error" and "Power Supply Rejection" specs are based on this unit to eliminate dependence on a particular V_{REF} value and to indicate the true performance of the part. The "Linearity Error" specification of the DAC1006 is "0.05% of FSR (MAX)." This guarantees that after performing a zero and full scale adjustment (See Sections 2.5 and 2.6), the plot of the 1024 analog voltage outputs will each be within $0.05\% \times V_{REF}$ of a straight line which passes through zero and full scale.

Note 8: This specification implies that all parts are guaranteed to operate with a write pulse or transfer pulse width (t_W) of 320 ns. A typical part will operate with t_W of only 100 ns. The entire write pulse must occur within the valid data interval for the specified t_W , t_{DS} , t_{DH} , and t_S to apply.

Note 9: Guaranteed by design but not tested.

Note 10: A 200 nA leakage current with $R_b = 20K$ and $V_{REF} = 10V$ corresponds to a zero error of $(200 \times 10^{-9} \times 20 \times 10^3) \times 100 \div 10$ which is 0.04% of FS.

Note 11: Human body model, 100 pF discharged through a 1.5 k Ω resistor.

Switching Waveforms

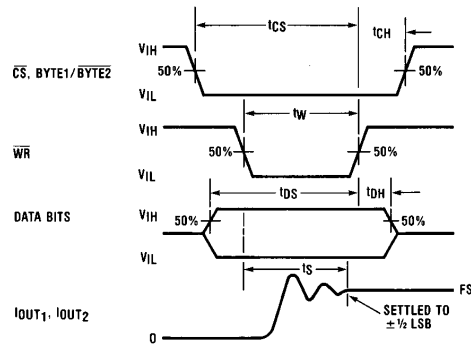

TL/H/5688-2

Typical Performance Characteristics

Errors vs. Supply Voltage

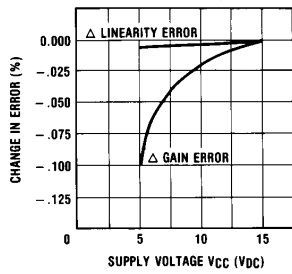

Errors vs. Temperature

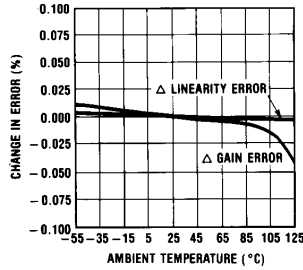

Write Width, t_W

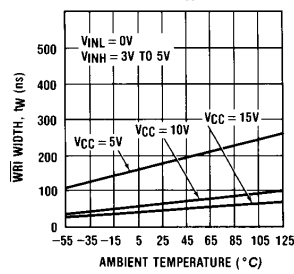

Control Setup Time, t_{CS}

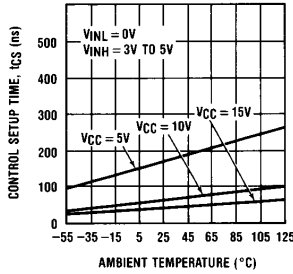

Data Setup Time, t_{DS}

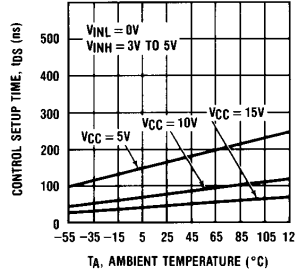

Data Hold Time, t_{DH}

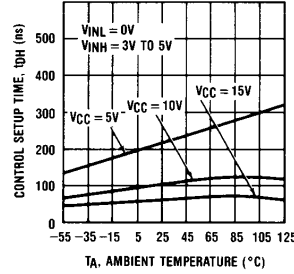

Digital Threshold vs. Supply Voltage

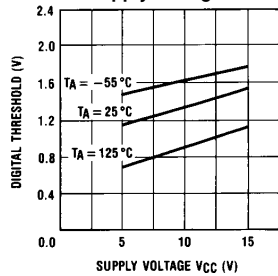

Digital Input Threshold vs. Temperature

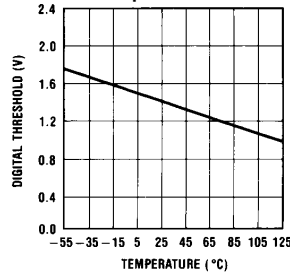

TL/H/5688-3

Block and Connection Diagrams

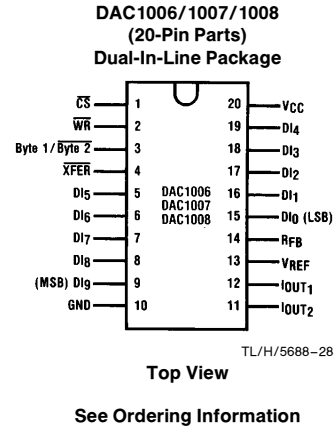
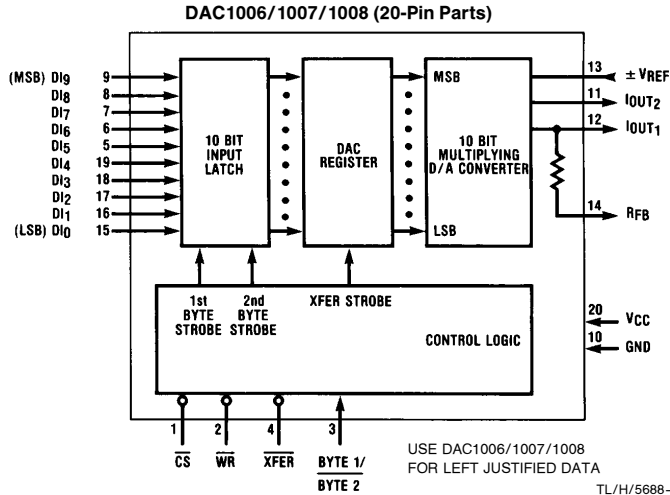

DAC1006/1007/1008—Simple Hookup for a “Quick Look”

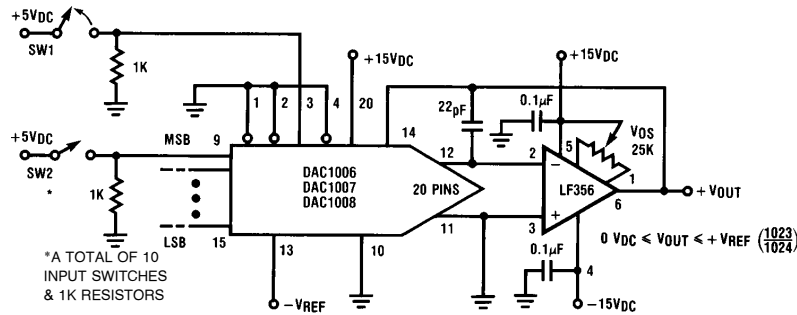

Notes:

1. For $V_{REF} = -10.240 V_{DC}$ the output voltage steps are approximately 10 mV each.
2. SW1 is a normally closed switch. While SW1 is closed, the DAC register is latched and new data can be loaded into the input latch via the 10 SW2 switches. When SW1 is momentarily opened the new data is transferred from the input latch to the DAC register and is latched when SW1 again closes.

1.0 DEFINITION OF PACKAGE PINOUTS

1.1 Control Signals (All control signals are level actuated.)

\overline{CS} : Chip Select — active low, it will enable \overline{WR} .

\overline{WR} : Write — The active low \overline{WR} is used to load the digital data bits (DI) into the input latch. The data in the input latch is latched when \overline{WR} is high. The 10-bit input latch is split into two latches; one holds 8 bits and the other holds 2 bits. The Byte1/Byte2 control pin is used to select both input latches when Byte1/Byte2 = 1 or to overwrite the 2-bit input latch when in the low state.

Byte1/Byte2: Byte Sequence Control — When this control is high, all ten locations of the input latch are enabled. When low, only two locations of the input latch are enabled and these two locations are overwritten on the second byte write. On the DAC1006, 1007, and 1008, the Byte1/Byte2 must be low to transfer the 10-bit data in the input latch to the DAC register.

\overline{XFER} : Transfer Control Signal, active low — This signal, in combination with others, is used to transfer the 10-bit data which is available in the input latch to the DAC register — see timing diagrams.

1.2 Other Pin Functions

DI_i (i = 0 to 9): Digital Inputs — DI₀ is the least significant bit (LSB) and DI₉ is the most significant bit (MSB).

I_{OUT1}: DAC Current Output 1 — I_{OUT1} is a maximum for a digital input code of all 1s and is zero for a digital input code of all 0s.

I_{OUT2}: DAC Current Output 2 — I_{OUT2} is a constant minus I_{OUT1}, or

$$I_{OUT1} + I_{OUT2} = \frac{1023 V_{REF}}{1024 R}$$

where $R \cong 15 \text{ k}\Omega$.

R_{FB}: Feedback Resistor — This is provided on the IC chip for use as the shunt feedback resistor when an external op amp is used to provide an output voltage for the DAC. This on-chip resistor should always be used (not an external resistor) because it matches the resistors used in the on-chip R-2R ladder and tracks these resistors over temperature.

V_{REF}: Reference Voltage Input — This is the connection for the external precision voltage source which drives the R-2R ladder. V_{REF} can range from -10 to +10 volts. This is also the analog voltage input for a 4-quadrant multiplying DAC application.

V_{CC}: Digital Supply Voltage — This is the power supply pin for the part. V_{CC} can be from +5 to +15 V_{DC}. Operation is optimum for +15V. The input threshold voltages are nearly independent of V_{CC}. (See Typical Performance Characteristics and Description in Section 3.0, T²L compatible logic inputs.)

GND: Ground — the ground pin for the part.

1.3 Definition of Terms

Resolution: Resolution is directly related to the number of switches or bits within the DAC. For example, the DAC1006 has 2¹⁰ or 1024 steps and therefore has 10-bit resolution.

Linearity Error: Linearity error is the maximum deviation from a straight line passing through the endpoints of the DAC transfer characteristic. It is measured after adjusting for zero and full-scale. Linearity error is a parameter intrinsic to the device and cannot be externally adjusted.

National's linearity test (a) and the "best straight line" test (b) used by other suppliers are illustrated below. The "best straight line" requires a special zero and FS adjustment for each part, which is almost impossible for user to determine. The "end point test" uses a standard zero and FS adjustment procedure and is a much more stringent test for DAC linearity.

Power Supply Sensitivity: Power supply sensitivity is a measure of the effect of power supply changes on the DAC full-scale output (which is the worst case).

a. End Point Test After Zero and FS Adj.

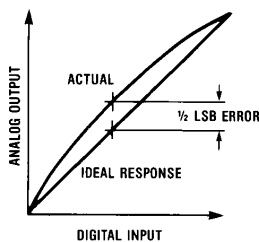

b. Best Straight Line

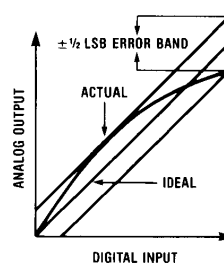

TL/H/5688-8

Settling Time: Settling time is the time required from a code transition until the DAC output reaches within $\pm 1/2$ LSB of the final output value. Full-scale settling time requires a zero to full-scale or full-scale to zero output change.

Full-Scale Error: Full scale error is a measure of the output error between an ideal DAC and the actual device output. Ideally, for the DAC1006 series, full-scale is $V_{REF} - 1$ LSB. For $V_{REF} = -10V$ and unipolar operation, $V_{FULL-SCALE} = 10.0000V - 9.8mV = 9.9902V$. Full-scale error is adjustable to zero.

Monotonicity: If the output of a DAC increases for increasing digital input code, then the DAC is monotonic. A 10-bit DAC with 10-bit monotonicity will produce an increasing analog output when all 10 digital inputs are exercised. A 10-bit DAC with 9-bit monotonicity will be monotonic when only the most significant 9 bits are exercised. Similarly, 8-bit monotonicity is guaranteed when only the most significant 8 bits are exercised.

2.0 DOUBLE BUFFERING

These DACs are double-buffered, microprocessor compatible versions of the DAC1020 10-bit multiplying DAC. The addition of the buffers for the digital input data not only allows for storage of this data, but also provides a way to assemble the 10-bit input data word from two write cycles when using an 8-bit data bus. Thus, the next data update for the DAC output can be made with the complete new set of 10-bit data. Further, the double buffering allows many DACs in a system to store current data and also the next data. The updating of the new data for each DAC is also not time critical. When all DACs are updated, a common strobe signal can then be used to cause all DACs to switch to their new analog output levels.

3.0 TTL COMPATIBLE LOGIC INPUTS

To guarantee TTL voltage compatibility of the logic inputs, a novel bipolar (NPN) regulator circuit is used. This makes the input logic thresholds equal to the forward drop of two diodes (and also matches the temperature variation) as occurs naturally in TTL. The basic circuit is shown in *Figure 1*. A curve of digital input threshold as a function of power supply voltage is shown in the Typical Performance Characteristics section.

4.0 APPLICATION HINTS

The DC stability of the V_{REF} source is the most important factor to maintain accuracy of the DAC over time and temperature changes. A good single point ground for the analog signals is next in importance.

These MICRO-DAC converters are CMOS products and reasonable care should be exercised in handling them prior to final mounting on a PC board. The digital inputs are protected, but permanent damage may occur if the part is subjected to high electrostatic fields. Store unused parts in conductive foam or anti-static rails.

4.1 Power Supply Sequencing & Decoupling

Some IC amplifiers draw excessive current from the Analog inputs to V_{-} when the supplies are first turned on. To prevent damage to the DAC — an external Schottky diode connected from I_{OUT1} or I_{OUT2} to ground may be required to prevent destructive currents in I_{OUT1} or I_{OUT2} . If an LM741 or LF356 is used — these diodes are not required.

The standard power supply decoupling capacitors which are used for the op amp are adequate for the DAC.

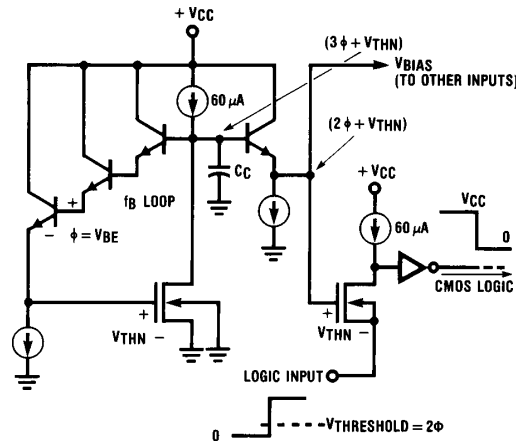

FIGURE 1. Basic Logic Threshold Loop

TL/H/5688-9

4.2 Op Amp Bias Current & Input Leads

The op amp bias current (I_B) CAN CAUSE DC ERRORS. BI-FET™ op amps have very low bias current, and therefore the error introduced is negligible. BI-FET op amps are strongly recommended for these DACs.

The distance from the I_{OUT1} pin of the DAC to the inverting input of the op amp should be kept as short as possible to prevent inadvertent noise pickup.

5.0 ANALOG APPLICATIONS

The analog section of these DACs uses an R-2R ladder which can be operated both in the current switching mode and in the voltage switching mode.

The major product changes (compared with the DAC1020) have been made in the digital functioning of the DAC. The analog functioning is reviewed here for completeness. For additional analog applications, such as multipliers, attenuators, digitally controlled amplifiers and low frequency sine wave oscillators, refer to the DAC1020 data sheet. Some basic circuit ideas are presented in this section in addition to complete applications circuits.

5.1 Operation in Current Switching Mode

The analog circuitry, *Figure 2*, consists of a silicon-chromium (Si-Cr) thin film R-2R ladder which is deposited on the surface oxide of the monolithic chip. As a result, there is no parasitic diode connected to the V_{REF} pin as would exist if diffused resistors were used. The reference voltage input (V_{REF}) can therefore range from $-10V$ to $+10V$.

The digital input code to the DAC simply controls the position of the SPDT current switches, SW0 to SW9. A logical 1 digital input causes the current switch to steer the avail-

able ladder current to the I_{OUT1} output pin. These MOS switches operate in the current mode with a small voltage drop across them and can therefore switch currents of either polarity. This is the basis for the 4-quadrant multiplying feature of this DAC.

5.1.1 Providing a Unipolar Output Voltage with the DAC in the Current Switching Mode

A voltage output is provided by making use of an external op amp as a current-to-voltage converter. The idea is to use the internal feedback resistor, R_{FB} , from the output of the op amp to the inverting ($-$) input. Now, when current is entered at this inverting input, the feedback action of the op amp keeps that input at ground potential. This causes the applied input current to be diverted to the feedback resistor. The output voltage of the op amp is forced to a voltage given by:

$$V_{OUT} = -(I_{OUT1} \times R_{FB})$$

Notice that the sign of the output voltage depends on the direction of current flow through the feedback resistor.

In current switching mode applications, both current output pins (I_{OUT1} and I_{OUT2}) should be operated at $0 V_{DC}$. This is accomplished as shown in *Figure 3*. The capacitor, C_C , is used to compensate for the output capacitance of the DAC and the input capacitance of the op amp. The required feedback resistor, R_{FB} , is available on the chip (one end is internally tied to I_{OUT1}) and must be used since an external resistor will not provide the needed matching and temperature tracking. This circuit can therefore be simplified as

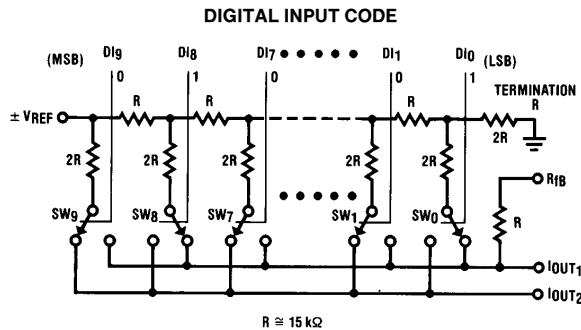

FIGURE 2. Current Mode Switching

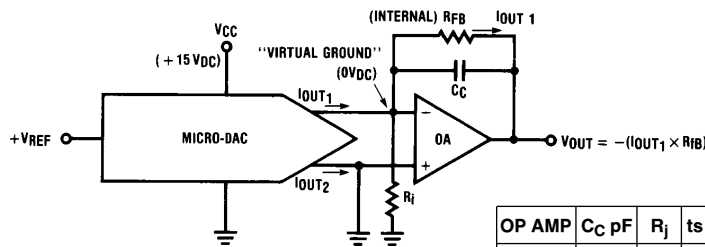

FIGURE 3. Converting I_{OUT} to V_{OUT}

OP AMP	C_C pF	R_i	t_s μ S
LF356	22	∞	3
LF351	24	∞	4
LF357	10	2.4k	1.5

TL/H/5688-10

shown in Figure 4, where the sign of the reference voltage has been changed to provide a positive output voltage. Note that the output current, I_{OUT1} , now flows through the R_{FB} pin.

5.1.2 Providing a Bipolar Output Voltage with the DAC in the Current Switching Mode

The addition of a second op amp to the circuit of Figure 4 can be used to generate a bipolar output voltage from a fixed reference voltage Figure 5. This, in effect, gives sign significance to the MSB of the digital input word to allow two quadrant multiplication of the reference voltage. The polarity of the reference can also be reversed to realize the full four-quadrant multiplication.

The applied digital word is offset binary which includes a code to output zero volts without the need of a large valued resistor common to existing bipolar multiplying DAC circuits. Offset binary code can be derived from 2's complement data (most common for signed processor arithmetic) by inverting the state of the MSB in either software or hardware. After doing this the output then responds in accordance to the following expression:

$$V_O = V_{REF} \times \frac{D}{512}$$

where V_{REF} can be positive or negative and D is the signed decimal equivalent of the 2's complement processor data. ($-512 \leq D \leq +511$ or $1000000000 \leq D \leq 0111111111$). If the applied digital input is interpreted as the decimal equivalent of a true binary word, V_{OUT} can be found by:

$$V_O = V_{REF} \left(\frac{D-512}{512} \right) \quad 0 \leq D \leq 1023$$

With this configuration, only the offset voltage of amplifier 1 need be nulled to preserve linearity of the DAC. The offset voltage error of the second op amp has no effect on linearity. It presents a constant output voltage error and should be nulled only if absolute accuracy is needed. Another advantage of this configuration is that the values of the external resistors required do not have to match the value of the internal DAC resistors; they need only to match and temperature track each other.

A thin film 4 resistor network available from Beckman Instruments, Inc. (part no. 694-3-R10K-D) is ideally suited for this application. Two of the four available $10 \text{ k}\Omega$ resistor can be paralleled to form R in Figure 5 and the other two can be used separately as the resistors labeled $2R$.

Operation is summarized in the table below:

2's Comp. (Decimal)	2's Comp. (Binary)	Applied Digital Input	Applied True Binary (Decimal)	V_{OUT}	
				$+V_{REF}$	$-V_{REF}$
+ 511	0111111111	1111111111	1023	$V_{REF} - 1 \text{ LSB}$	$- V_{REF} + 1 \text{ LSB}$
+ 256	0100000000	1100000000	768	$V_{REF}/2$	$- V_{REF} /2$
0	0000000000	1000000000	512	0	0
- 1	1111111111	0111111111	511	-1 LSB	+1 LSB
- 256	1100000000	0100000000	256	$-V_{REF}/2$	$+ V_{REF} /2$
- 512	1000000000	0000000000	0	$-V_{REF}$	$+ V_{REF} $

with: $1 \text{ LSB} = \frac{|V_{REF}|}{512}$

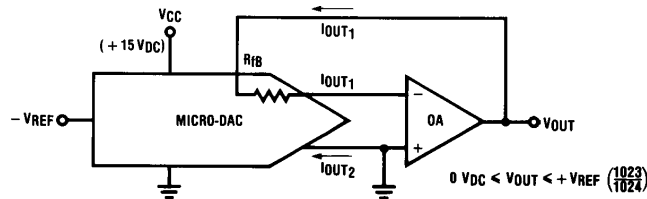

FIGURE 4. Providing a Unipolar Output Voltage

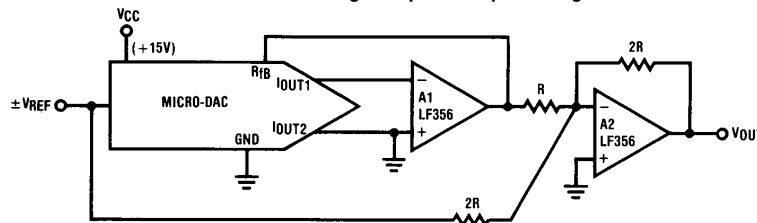

FIGURE 5. Providing a Bipolar Output Voltage with the DAC in the Current Switching Mode

TL/H/5688-11

5.2 Analog Operation in the Voltage Switching Mode

Some useful application circuits result if the R-2R ladder is operated in the voltage switching mode. There are two very important things to remember when using the DAC in the voltage mode. The reference voltage (+V) must always be positive since there are parasitic diodes to ground on the IOUT1 pin which would turn on if the reference voltage went negative. To maintain a degradation of linearity less than $\pm 0.005\%$, keep $+V \leq 3 V_{DC}$ and V_{CC} at least 10V more positive than +V. Figures 6 and 7 show these errors for the voltage switching mode. This operation appears unusual, since a reference voltage (+V) is applied to the IOUT1 pin and the voltage output is the VREF pin. This basic idea is shown in Figure 8.

This V_{OUT} range can be scaled by use of a non-inverting gain stage as shown in Figure 9.

Notice that this is unipolar operation since all voltages are positive. A bipolar output voltage can be obtained by using a single op amp as shown in Figure 10. For a digital input code of all zeros, the output voltage from the VREF pin is zero volts. The external op amp now has a single input of +V and is operating with a gain of -1 to this input. The output of the op amp therefore will be at -V for a digital input of all zeros. As the digital code increases, the output voltage at the VREF pin increases.

Notice that the gain of the op amp to voltages which are applied to the (+) input is +2 and the gain to voltages which are applied to the input resistor, R, is -1. The output voltage of the op amp depends on both of these inputs and is given by:

$$V_{OUT} = (+V)(-1) + V_{REF}(+2)$$

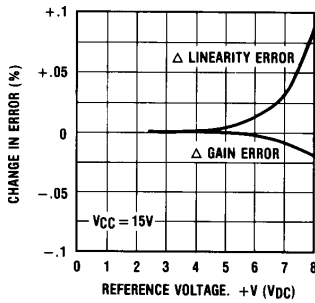

FIGURE 6

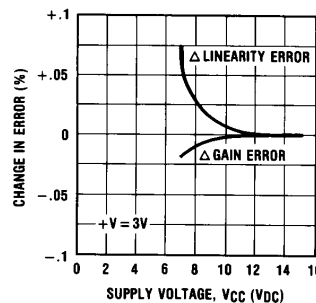

FIGURE 7

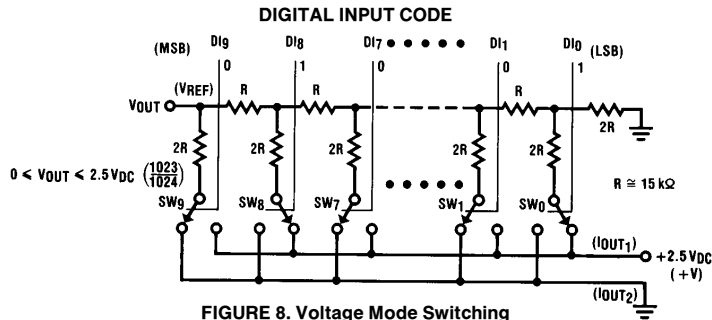

FIGURE 8. Voltage Mode Switching

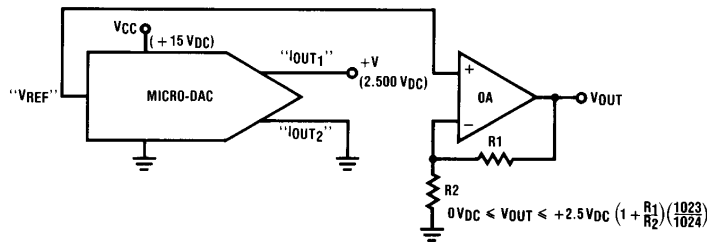

FIGURE 9. Amplifying the Voltage Mode Output (Single Supply Operation)

TL/H/5688-12

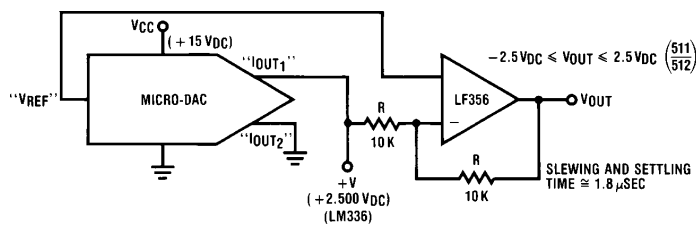

FIGURE 10. Providing a Bipolar Output Voltage with a Single Op Amp

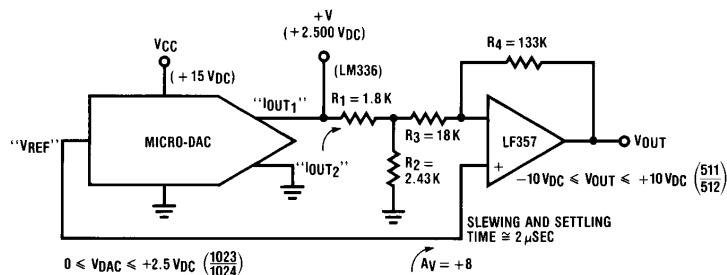

FIGURE 11. Increasing the Output Voltage Swing

TL/H/5688-13

The output voltage swing can be expanded by adding 2 resistors to *Figure 10* as shown in *Figure 11*. These added resistors are used to attenuate the +V voltage. The overall gain, $A_V(-)$, from the +V terminal to the output of the op amp determines the most negative output voltage, $-4(+V)$ (when the V_{REF} voltage at the + input of the op amp is zero) with the component values shown. The complete dynamic range of V_{OUT} is provided by the gain from the (+) input of the op amp. As the voltage at the V_{REF} pin ranges from 0V to $+V(1023/1024)$ the output of the op amp will range from $-10V_{DC}$ to $+10V(1023/1024)$ when using a +V voltage of $+2.500V_{DC}$. The $2.5V_{DC}$ reference voltage can be easily developed by using the LM336 zener which can be biased through the R_{FB} internal resistor, connected to V_{CC} .

5.3 Op Amp V_{OS} Adjust (Zero Adjust) for Current Switching Mode

Proper operation of the ladder requires that all of the 2R legs always go to exactly 0 V_{DC} (ground). Therefore offset voltage, V_{OS} , of the external op amp cannot be tolerated as every millivolt of V_{OS} will introduce 0.01% of added linearity error. At first this seems unusually sensitive, until it becomes clear the 1 mV is 0.01% of the 10V reference! High resolution converters of high accuracy require attention to every detail in an application to achieve the available performance which is inherent in the part. To prevent this source of error, the V_{OS} of the op amp has to be initially zeroed. This is the "zero adjust" of the DAC calibration sequence and should be done first.

If the V_{OS} is to be adjusted there are a few points to consider. Note that no "dc balancing" resistance should be used in the grounded positive input lead of the op amp. This resistance and the input current of the op amp can also create errors. The low input biasing current of the BI-FET op amps makes them ideal for use in DAC current to voltage applications. The V_{OS} of the op amp should be adjusted with a digital input of all zeros to force $I_{OUT} = 0$ mA. A 1 k Ω resistor can be temporarily connected from the inverting input to ground to provide a dc gain of approximately 15 to the V_{OS} of the op amp and make the zeroing easier to sense.

5.4 Full-Scale Adjust

The full-scale adjust procedure depends on the application circuit and whether the DAC is operated in the current switching mode or in the voltage switching mode. Techniques are given below for all of the possible application circuits.

5.4.1 Current Switching with Unipolar Output Voltage

After doing a "zero adjust," set all of the digital input levels HIGH and adjust the magnitude of V_{REF} for

$$V_{OUT} = -(\text{ideal } V_{REF}) \frac{1023}{1024}$$

This completes the DAC calibration.

5.4.2 Current Switching with Bipolar Output Voltage

The circuit of *Figure 12* shows the 3 adjustments needed. The first step is to set all of the digital inputs LOW (to force I_{OUT1} to 0) and then trim "zero adj." for zero volts at the inverting input (pin 2) of OA1. Next, with a code of all zeros still applied, adjust "-FS adj.", the reference voltage, for $V_{OUT} = \pm$ (ideal V_{REF}). The sign of the output voltage will be opposite that of the applied reference.

Finally, set all of the digital inputs HIGH and adjust "+FS adj." for $V_{OUT} = V_{REF}$ (511/512). The sign of the output at this time will be the same as that of the reference voltage. The addition of the 200Ω resistor in series with the V_{REF} pin of the DAC is to force the circuit gain error from the DAC to be negative. This insures that adding resistance to R_{fb} , with the 500Ω pot, will always compensate the gain error of the DAC.

5.4.3 Voltage Switching with a Unipolar Output Voltage

Refer to the circuit of *Figure 13* and set all digital inputs LOW. Trim the "zero adj." for $V_{OUT} = 0 V_{DC} \pm 1$ mV. Then set all digital inputs HIGH and trim the "FS Adj." for:

$$V_{OUT} = (+V) \left(1 + \frac{R_1}{R_2} \right) \frac{1023}{1024}$$

5.4.4 Voltage Switching with a Bipolar Output Voltage

Refer to *Figure 14* and set all digital inputs LOW. Trim the "-FS Adj." for $V_{OUT} = -2.5 V_{DC}$. Then set all digital inputs HIGH and trim the "+FS Adj." for $V_{OUT} = +2.5$ (511/512) V_{DC} . Test the zero by setting the MS digital input HIGH and all the rest LOW. Adjust V_{OS} of amp #3, if necessary, and recheck the full-scale values.

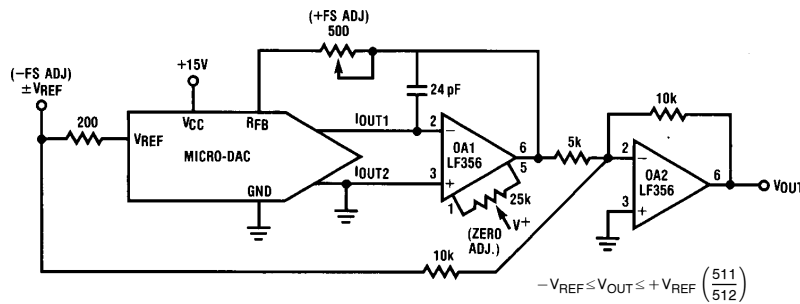

FIGURE 12. Full Scale Adjust — Current Switching with Bipolar Output Voltage

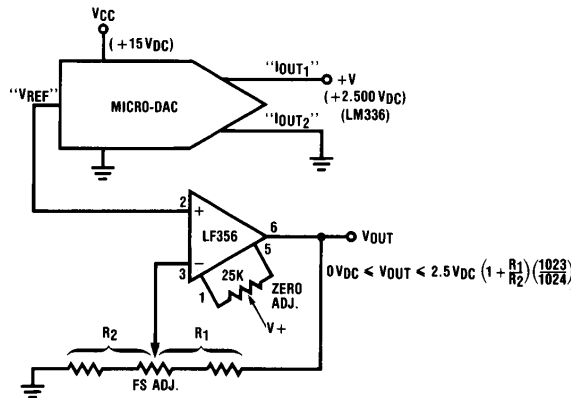

FIGURE 13. Full Scale Adjust — Voltage Switching with a Unipolar Output Voltage

TL/H/5688-14

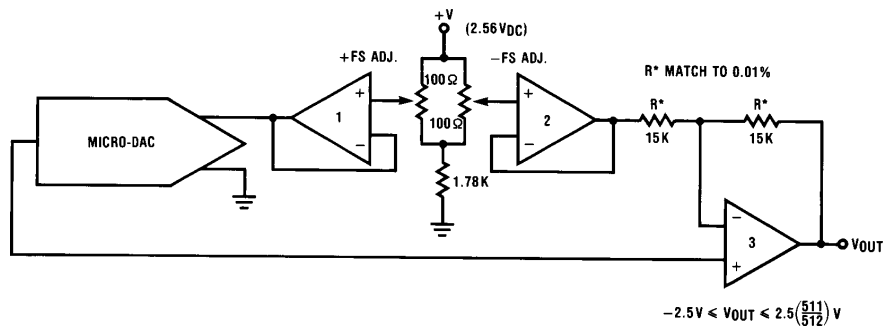

FIGURE 14. Voltage Switching with a Bipolar Output Voltage

TL/H/5688-15

6.0 DIGITAL CONTROL DESCRIPTION

The DAC1006 series of products can be used in a wide variety of operating modes. Most of the options are shown in Table 1. Also shown in this table are the section numbers of this data sheet where each of the operating modes is discussed. For example, if your main interest in interfacing to a μP with an 8-bit data bus you will be directed to Section 6.1.0.

The first consideration is "will the DAC be interfaced to a μP with an 8-bit or a 16-bit data bus or used in the stand-alone mode?" For the 8-bit data bus, a second selection is made on how the 2nd digital data buffer (the DAC Latch) is updated by a transfer from the 1st digital data buffer (the Input Latch). Three options are provided: 1) an automatic transfer when the 2nd data byte is written to the DAC, 2) a transfer which is under the control of the μP and can include more than one DAC in a simultaneous transfer, or 3) a transfer which is under the control of external logic. Further, the data format can be either left justified or right justified.

When interfacing to a μP with a 16-bit data bus only two selections are available: 1) operating the DAC with a single digital data buffer (the transfer of one DAC does not have to be synchronized with any other DACs in the system), or

2) operating with a double digital data buffer for simultaneous transfer, or updating, of more than one DAC.

For operating without a μP in the stand alone mode, three options are provided: 1) using only a single digital data buffer, 2) using both digital data buffers — "double buffered," or 3) allowing the input digital data to "flow through" to provide the analog output without the use of any data latches.

To reduce the required reading, only the applicable sections of 6.1 through 6.4 need be considered.

6.1 Interfacing to an 8-Bit Data Bus

Transferring 10 bits of data over an 8-bit bus requires two write cycles and provides four possible combinations which depend upon two basic data format and protocol decisions:

1. Is the data to be left justified (considered as fractional binary data with the binary point to the left) or right justified (considered as binary weighted data with the binary point to the right)?
2. Which byte will be transferred first, the most significant byte (MS byte) or the least significant byte (LS byte)?

Table 1

Operating Mode	Automatic Transfer		μP Control Transfer		External Transfer	
	Section	Figure No.	Section	Figure No.	Section	Figure No.
Data Bus						
8-Bit Data Bus (6.1.0) Left Justified (6.1.1)	6.2.1	16	6.2.2	16	6.2.3	16
16-Bit Data Bus (6.3.0)	Single Buffered		Double Buffered		Flow Through	
	6.3.1	17	6.3.2	17	Not Applicable	
Stand Alone (6.4.0)	Single Buffered		Double Buffered		Flow Through	
	6.4.1	17	6.4.2	17	NA	

These data possibilities are shown in *Figure 15*. Note that the justification of data depends on how the 10-bit data word is located within the 16-bit data source (CPU) register. In either case, there is a surplus of 6 bits and these are shown as "don't care" terms ("X") in this figure.

All of these DACs load 10 bits on the 1st write cycle. A particular set of 2 bits is then overwritten on the 2nd write cycle, depending on the justification of the data. For all left justified data options, the 1st write cycle must contain the MS or Hi Byte data group.

6.1.1 For Left Justified Data

For applications which require left justified data, DAC1006-1008 can be used. A simplified logic diagram which shows the external connections to the data bus and the internal functions of both of the data buffer registers (Input Latch and DAC Register) is shown in *Figure 16*. These

parts require the MS or Hi Byte data group to be transferred on the 1st write cycle.

6.2 Controlling Data Transfer for an 8-Bit Data Bus

Three operating modes are possible for controlling the transfer of data from the Input Latch to the DAC Register, where it will update the analog output voltage. The simplest is the automatic transfer mode, which causes the data transfer to occur at the time of the 2nd write cycle. This is recommended when the exact timing of the changes of the DAC analog output are not critical. This typically happens where each DAC is operating individually in a system and the analog updating of one DAC is not required to be synchronized to any other DAC. For synchronized DAC updating, two options are provided: μ P control via a common XFER strobe or external update timing control via an external strobe. The details of these options are now shown.

DAC1006/1007/1008 (20-Pin Parts for Left Justified Data)

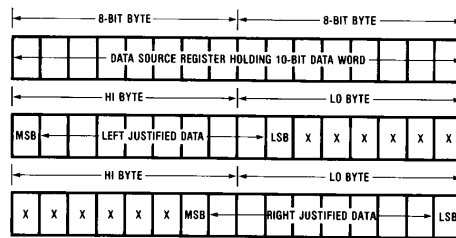

TL/H/5688-16

FIGURE 15. Fitting a 10-Bit Data Word into 16 Available Bit Locations

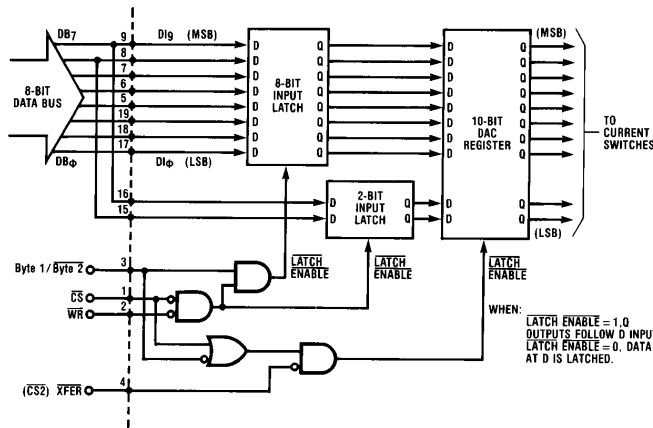

TL/H/5688-17

FIGURE 16. Input Connections and Controls for DAC1006/1007/1008 Left Justified Data

6.2.1 Automatic Transfer

This makes use of a double byte (double precision) write. The first byte (8 bits) is strobed into the input latch and the second byte causes a simultaneous strobe of the two remaining bits into the input latch and also the transfer of the complete 10-bit word from the input latch to the DAC register. This is shown in the following timing diagram; the point in time where the analog output is updated is also indicated on this diagram.

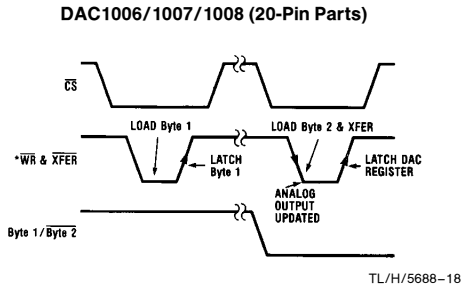

*SIGNIFIES CONTROL INPUTS WHICH ARE DRIVEN IN PARALLEL

6.2.2 Transfer Using μ P Write Stroke

The input latch is loaded with the first two write strobes. The $\overline{\text{XFER}}$ signal is provided by external logic, as shown below, to cause the transfer to be accomplished on a third write strobe. This is shown in the following diagram:

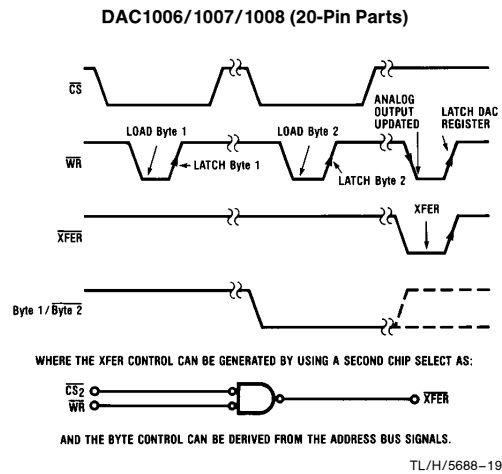

6.2.3 Transfer Using an External Strobe

This is similar to the previous operation except the $\overline{\text{XFER}}$ signal is not provided by the μ P. The timing diagram for this is:

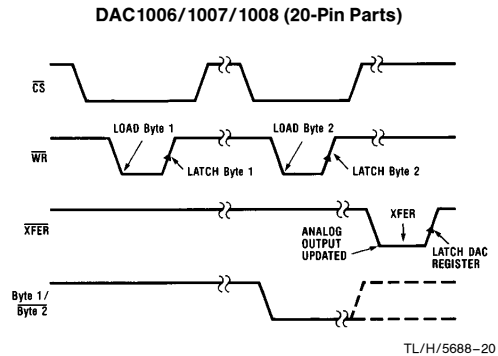

6.3 Interfacing to a 16-Bit Data Bus

The interface to a 16-bit data bus is easily handled by connecting to 10 of the available bus lines. This allows a wiring selected right justified or left justified data format. This is shown in the connection diagram of *Figure 17*, where the use of DB6 to DB15 gives left justified data operation. Note that any part number can be used and the Byte1/Byte2 control should be wired Hi.

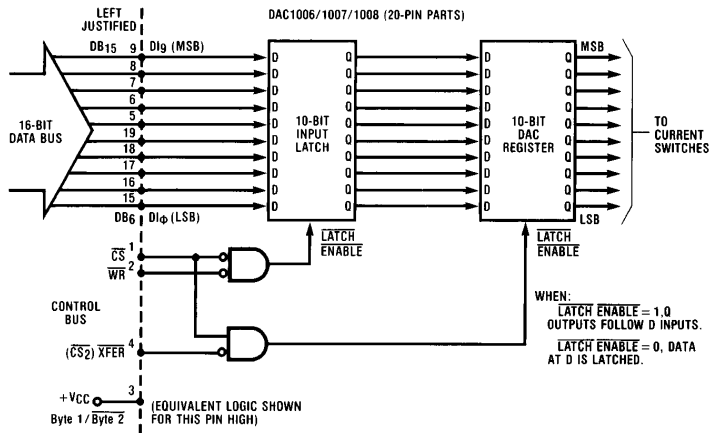

TL/H/5688-21

FIGURE 17. Input Connections and Logic for DAC1006/1007/1008 with 16-Bit Data Bus

Three operating modes are possible: flow through, single buffered, or double buffered. The timing diagrams for these are shown below:

**6.3.1 Single Buffered
DAC1006/1007/1008 (20-Pin Parts)**

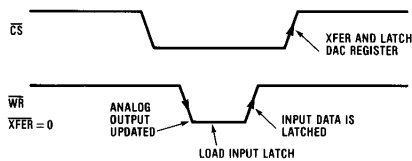

**6.3.2 Double Buffered
DAC1006/1007/1008 (20-Pin Parts)**

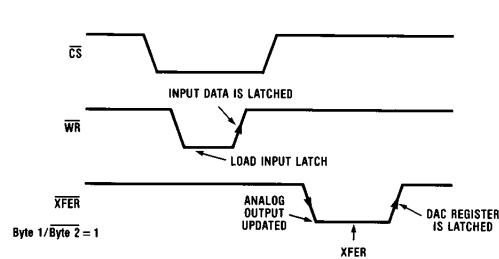

TL/H/5688-22

*For a connection diagram of this operating mode use Figure 16 for the Logic and Figure 17 for the Data Input connections.

6.4 Stand Alone Operation

For applications for a DAC which are not under μP control (stand alone) there are two basic operating modes, single buffered and double buffered. The timing diagrams for these are shown below:

**6.4.1 Single Buffered
DAC1006/1007/1008 (20-Pin Parts)**

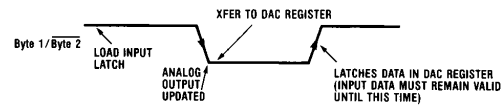

**6.4.2 Double Buffered
DAC1006/1007/1008 (20-Pin Parts)***

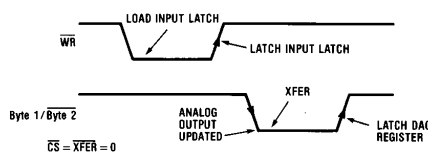

TL/H/5688-23

7.0 MICROPROCESSOR INTERFACE

The logic functions of the DAC1006 family have been oriented towards an ease of interface with all popular μ Ps. The following sections discuss in detail a few useful interface schemes.

7.1 DAC1001/1/2 to INS8080A Interface

Figure 18 illustrates the simplicity of interfacing the DAC1006 to an INS8080A based microprocessor system.

The circuit will perform an automatic transfer of the 10 bits of output data from the CPU to the DAC register as outlined in Section 6.2.1, "Controlling Data Transfer for an 8-Bit Data Bus."

Since a double byte write is necessary to control the DAC with the INS8080A, a possible instruction to achieve this is a PUSH of a register pair onto a "stack" in memory. The 16-bit register pair word will contain the 10 bits of the eventual DAC input data in the proper sequence to conform to both

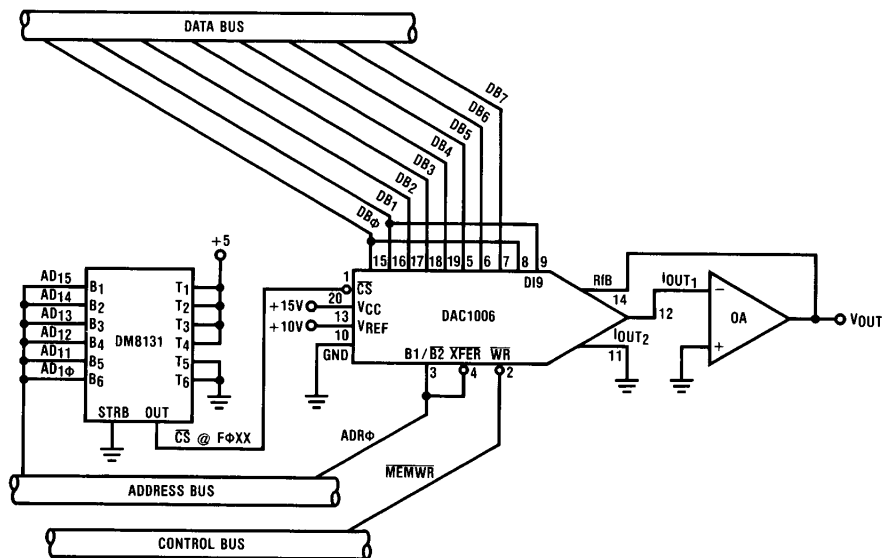

TL/H/5688-24

NOTE: DOUBLE BYTE STORES CAN BE USED.
e.g. THE INSTRUCTION SHLD F001 STORES THE L
REG INTO B1 AND THE H REG INTO B2 AND
TRANSFERS THE RESULT TO THE DAC REGISTER.
THE OPERAND OF THE SHLD INSTRUCTION MUST
BE AN ODD ADDRESS FOR PROPER TRANSFER.

FIGURE 18. Interfacing the DAC1000 to the INS8080A CPU Group

the requirements of the DAC (with regard to left justified data) and the implementation of the PUSH instruction which will output the higher order byte of the register pair (i.e., register B of the BC pair) first. The DAC will actually appear as a two-byte "stack" in memory to the CPU. The auto-decrementing of the stack pointer during a PUSH allows using address bit 0 of the stack pointer as the Byte1/Byte2 and XFER strobes if bit 0 of the stack pointer address - 1, (SP-1), is a "1" as presented to the DAC. Additional address decoding by the DM8131 will generate a unique DAC chip select (CS) and synchronize this CS to the two memory write strobes of the PUSH instruction.

To reset the stack pointer so new data may be output to the same DAC, a POP instruction followed by instructions to insure that proper data is in the DAC data register pair before it is "PUSHED" to the DAC should be executed, as the POP instruction will arbitrarily alter the contents of a register pair.

Another double byte write instruction is Store H and L Direct (SHLD), where the HL register pair would temporarily contain the DAC data and the two sequential addresses for the DAC are specified by the instruction op code. The auto incrementing of the DAC address by the SHLD instruction permits the same simple scheme of using address bit 0 to generate the byte number and transfer strobes.

7.2 DAC1006 to MC6820/1 PIA Interface

In Figure 19 the DAC1006 is interfaced to an M6800 system through an MC6820/1 Peripheral Interface Adapter (PIA). In this case the CS pin of the DAC is grounded since the PIA is already mapped in the 6800 system memory space and no decoding is necessary. Furthermore, by using both Ports A and B of the PIA the 10-bit data transfer, assumed left justified again in two 8-bit bytes, is greatly simplified. The HIGH byte is loaded into Output Register A (ORA) of the

PIA, and the LOW byte is loaded into ORB. The 10-bit data transfer to the DAC and the corresponding analog output change occur simultaneously upon CB2 going LOW under program control. The 10-bit data word in the DAC register will be latched (and hence V_{OUT} will be fixed) when CB2 is brought back HIGH.

If both output ports of the PIA are not available, it is possible to interface the DAC1006 through a single port without much effort. However, additional logic at the CB2(or CA2) lines or access to some of the 6800 system control lines will be required.

7.3 Noise Considerations

A typical digital/microprocessor bus environment is a tremendous potential source of high frequency noise which can be coupled to sensitive analog circuitry. The fast edges of the data and address bus signals generate frequency components of 10's of megahertz and can cause noise spikes to appear at the DAC output. These noise spikes occur when the data bus changes state or when data is transferred between the latches of the device.

In low frequency or DC applications, low pass filtering can reduce these noise spikes. This is accomplished by over-compensating the DAC output amplifier by increasing the value of the feedback capacitor (C_f in Figure 3).

In applications requiring a fast transient response from the DAC and op amp, filtering may not be feasible. Adding a latch, DM74LS374, as shown in Figure 20 isolates the device from the data bus, thus eliminating noise spikes that occur every time the data bus changes state. Another method for eliminating noise spikes is to add a sample and hold after the DAC op amp. This also has the advantage of eliminating noise spikes when changing digital codes.

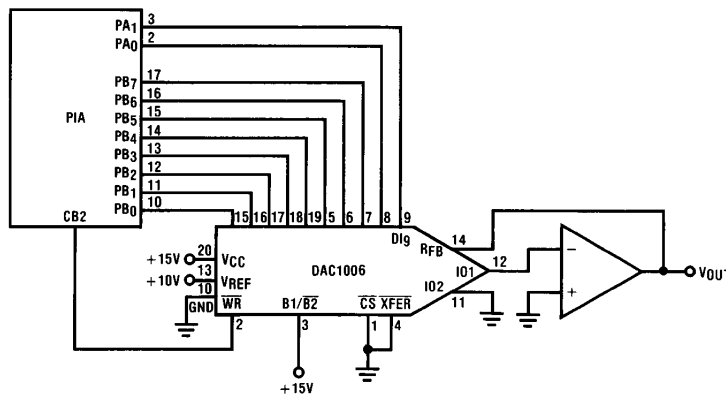

FIGURE 19. DAC1006 to MC6820/1 PIA Interface

TL/H/5688-25

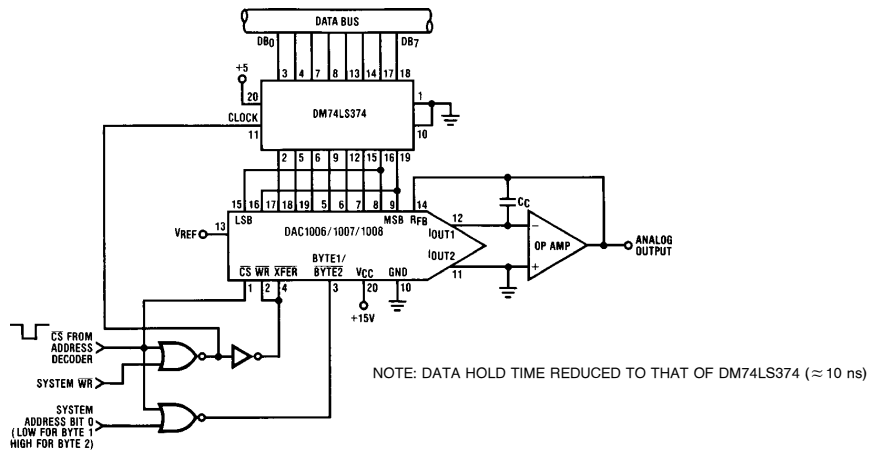

FIGURE 20. Isolating Data Bus from DAC Circuitry to Eliminate Digital Noise Coupling

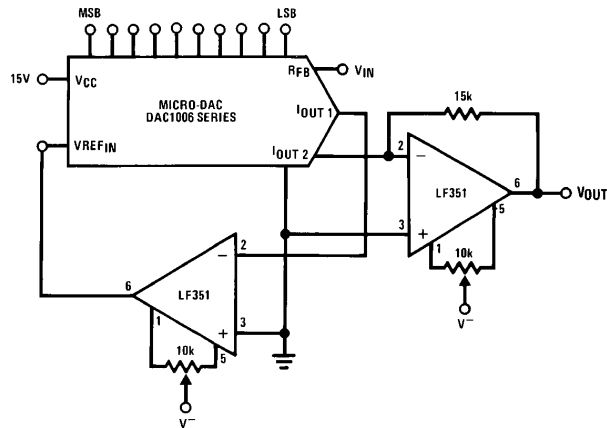

FIGURE 21. Digitally Controlled Amplifier/Attenuator

TL/H/5688-26

7.4 Digitally Controlled Amplifier/Attenuator

An unusual application of the DAC, *Figure 21*, applies the input voltage via the on-chip feedback resistor. The lower op amp automatically adjusts the $V_{REF\ IN}$ voltage such that I_{OUT1} is equal to the input current (V_{IN}/R_{fB}). The magnitude of this $V_{REF\ IN}$ voltage depends on the digital word which is in the DAC register. I_{OUT2} then depends upon both the magnitude of V_{IN} and the digital word. The second op amp converts I_{OUT2} to a voltage, V_{OUT} , which is given by:

$$V_{OUT} = V_{IN} \left(\frac{1023 - N}{N} \right), \text{ where } 0 < N \leq 1023.$$

Note that $N=0$ (or a digital code of all zeros) is not allowed or this will cause the output amplifier to saturate at either $\pm V_{MAX}$, depending on the sign of V_{IN} .

To provide a digitally controlled divider, the output op amp can be eliminated. Ground the I_{OUT2} pin of the DAC and V_{OUT} is now taken from the lower op amp (which also drives the V_{REF} input of the DAC). The expression for V_{OUT} is now given by

$$V_{OUT} = -\frac{V_{IN}}{M} \text{ where } M = \text{Digital input (expressed as a fractional binary number),}$$

$$0 < M < 1.$$

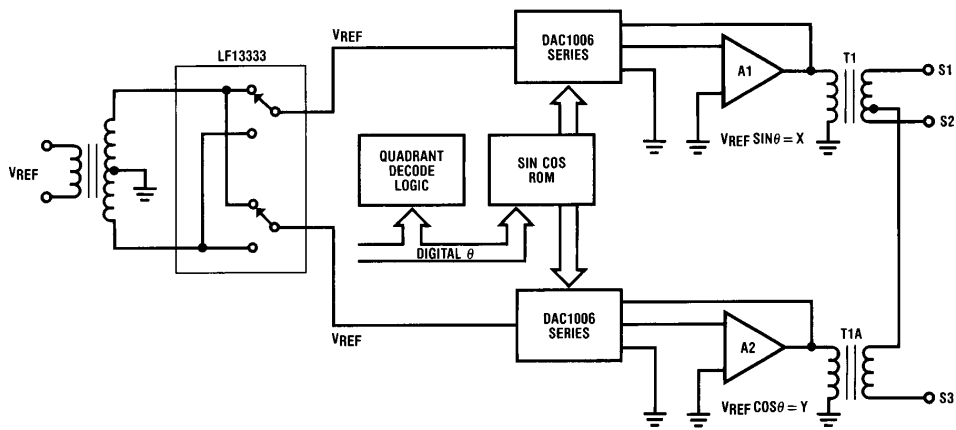

TL/H/5688-27

FIGURE 22. Digital to Synchro Converter

Ordering Information

For Left Justified Data — 20-pin package.

Accuracy	Temperature Range 0° to +70°C	
0.05% (10-bit)	DAC1006LCN	DAC1006LCWM
0.10% (9-bit)	DAC1007LCN	
0.20% (8-bit)	DAC1008LCN	
Package Outline	N20A	M20B

Physical Dimensions inches (millimeters)

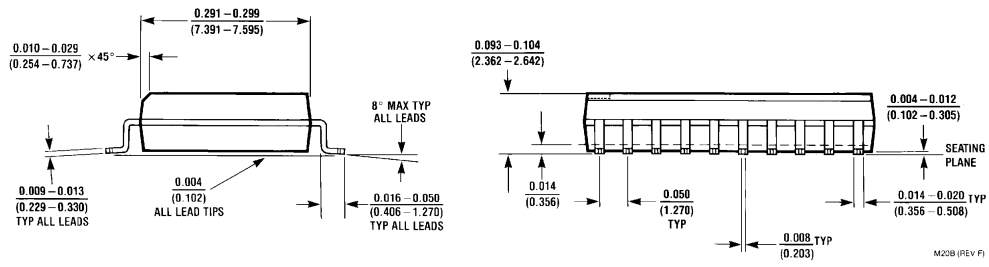
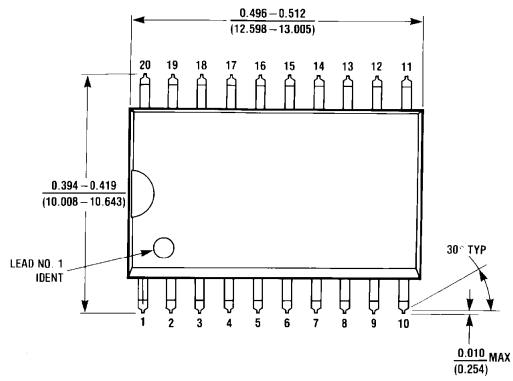

Order Number DAC1006LCWM
NS Package Number M20B

M20B (REV F)

**DAC1006/DAC1007/DAC1008 μ P Compatible,
 Double-Buffered D to A Converters**

Physical Dimensions inches (millimeters) (Continued)

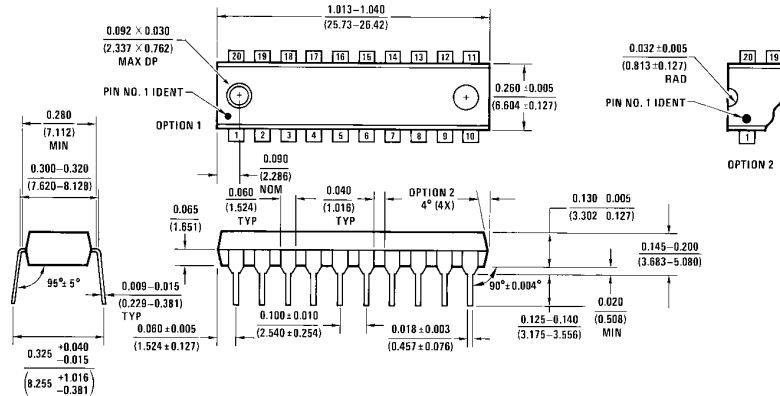

Order Number DAC1006LCN, DAC1007LCN or DAC1008LCN
 NS Package Number N20A

N20A (REV G)

LIFE SUPPORT POLICY

NATIONAL'S PRODUCTS ARE NOT AUTHORIZED FOR USE AS CRITICAL COMPONENTS IN LIFE SUPPORT DEVICES OR SYSTEMS WITHOUT THE EXPRESS WRITTEN APPROVAL OF THE PRESIDENT OF NATIONAL SEMICONDUCTOR CORPORATION. As used herein:

1. Life support devices or systems are devices or systems which, (a) are intended for surgical implant into the body, or (b) support or sustain life, and whose failure to perform, when properly used in accordance with instructions for use provided in the labeling, can be reasonably expected to result in a significant injury to the user.
2. A critical component is any component of a life support device or system whose failure to perform can be reasonably expected to cause the failure of the life support device or system, or to affect its safety or effectiveness.



National Semiconductor Corporation
 1111 West Bardin Road
 Arlington, TX 76017
 Tel: 1(800) 272-9959
 Fax: 1(800) 737-7018

National Semiconductor Europe
 Fax: (+49) 0-180-530 85 86
 Email: cnjwge@tevm2.nsc.com
 Deutsch Tel: (+49) 0-180-530 85 85
 English Tel: (+49) 0-180-532 78 32
 Français Tel: (+49) 0-180-532 93 58
 Italiano Tel: (+49) 0-180-534 16 80

National Semiconductor Hong Kong Ltd.
 19th Floor, Straight Block,
 Ocean Centre, 5 Canton Rd.
 Tsimshatsui, Kowloon
 Hong Kong
 Tel: (852) 2737-1600
 Fax: (852) 2736-9960

National Semiconductor Japan Ltd.
 Tel: 81-043-299-2309
 Fax: 81-043-299-2408

National does not assume any responsibility for use of any circuitry described, no circuit patent licenses are implied and National reserves the right at any time without notice to change said circuitry and specifications.

National Semiconductor was acquired by Texas Instruments.

http://www.ti.com/corp/docs/investor_relations/pr_09_23_2011_national_semiconductor.html

This file is the datasheet for the following electronic components:

DAC1000 - <http://www.ti.com/product/dac1000?HQS=TI-null-null-dscatalog-df-pf-null-wwe>

DAC1002 - <http://www.ti.com/product/dac1002?HQS=TI-null-null-dscatalog-df-pf-null-wwe>

DAC1001 - <http://www.ti.com/product/dac1001?HQS=TI-null-null-dscatalog-df-pf-null-wwe>

DAC1006 - <http://www.ti.com/product/dac1006?HQS=TI-null-null-dscatalog-df-pf-null-wwe>

DAC1008 - <http://www.ti.com/product/dac1008?HQS=TI-null-null-dscatalog-df-pf-null-wwe>

DAC1007 - <http://www.ti.com/product/dac1007?HQS=TI-null-null-dscatalog-df-pf-null-wwe>



LittleDiode supplies new, hard to find or obsolete electronic components and semiconductors all over the world.

With over two million different components listed you are sure to find the part you need.

Feel free to visit us today at our online store:

LittleDiode.com

Looking forward to providing you with the best possible service.