

DS8881 Vacuum Fluorescent Display Driver

General Description

The DS8881 vacuum fluorescent display driver will drive 16-digit grids of a vacuum fluorescent display. The decode inputs select one of the sixteen outputs to be pulled high. The device contains an oscillator for supplying clock signals to the MOS circuit, the filament bias zener and 50 kΩ pull-down resistors for each grid. Outputs will source up to 7 mA. The DS8881 is designed for 9V operation. If the enable input is pulled low, all outputs are disabled.

Features

- Oscillator frequency accuracy and stability allows maximum system speed
- Interdigit blanking with the enable input provides ghost-free display operation
- 50 kΩ pull-down resistors for each grid
- 7V filament bias zener

Connection Diagram

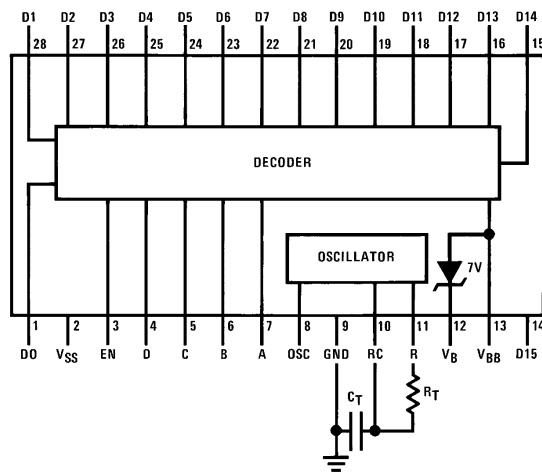

TL/F/5846-1

Top View

Order Number DS8881N
See NS Package Number N28B

Truth Table

All outputs now shown high are off (low)

Inputs					Digit Outputs															
E_N	D	C	B	A	0	1	2	3	4	5	6	7	8	9	10	11	12	13	14	15
H	L	L	L	L	H															
H	L	L	L	H		H														
H	L	L	H	L			H													
H	L	L	H	H				H												
H	L	H	L	L					H											
H	L	H	L	H						H										
H	L	H	H	L							H									
H	L	H	H	H								H								
H	H	L	L	L									H							
H	H	L	L	H										H						
H	H	L	H	H											H					
H	H	H	L	L												H				
H	H	H	L	H													H			
H	H	H	H	L														H		
H	H	H	H	H															H	
H	H	H	H	H																H
L	X	X	X	X	L	L	L	L	L	L	L	L	L	L	L	L	L	L	L	L

Absolute Maximum Ratings (Note 1)

If Military/Aerospace specified devices are required, please contact the National Semiconductor Sales Office/Distributors for availability and specifications.

Supply Voltage ($V_{SS}-V_{BB}$)	38V
Input Current	10 mA
Output Current	-20 mA
Storage Temperature	-65°C to +150°C
Maximum Power Dissipation* at 25°C	
Molded Package	2168 mW
Lead Temperature (Soldering, 4 sec.)	260°C

*Derate molded package 17.35 mW/°C above 25°C.

Operating Conditions

	Min	Max	Units
Supply Voltage			
V_{SS}	5.0	9.5	V
V_{BB}	Gnd	-26	V
Temperature (T_A)	0	+70	°C

Electrical Characteristics (Notes 2 and 3)

Symbol	Parameter	Conditions			Min	Typ	Max	Units	
V_{IH}	Logical "1" Input Voltage	$V_{SS} = \text{Max}$	Enable	$I_{IN} = 260 \mu\text{A}$			5.1	V	
			A, B, C, D	$I_{IN} = 1400 \mu\text{A}$			1.5	V	
I_{IH}	Logical "1" Input Current	$V_{SS} = \text{Max}$	Enable A, B, C, D				260	μA	
V_{IL}	Logical "0" Input Voltage	$V_{SS} = \text{Max}$	Enable				1.0	V	
			A, B, C, D				0.3	V	
I_{IL}	Logical "0" Input Current	$V_{SS} = \text{Max}$	Enable	$V_{IN} = 0\text{V}$			-1.0	μA	
			A, B, C, D	$V_{IN} = V_{IL(\text{MAX})}$	25			μA	
V_{OH}	Logical "1" Output Voltage	Digit Output, $I_{OH} = -7 \text{ mA}$			$V_{SS} - 2.5$			V	
I_{OH}	Logical "1" Output Current	$V_{SS} = \text{Max}$, Osc. Output, $V_{RC} = 0.6\text{V}$, $V_{OH} = 10\text{V}$					50	μA	
I_{OS}	Output Short-Circuit Current	$V_{SS} = \text{Min}$, Pin R, $V_{RC} = 0.6\text{V}$, $V_R = 0\text{V}$			-150		-450	μA	
R_{OUT}	Output Pull-Down Resistor	$V_{SS} = \text{Min}$, Digit Output			30	50	85	$\text{k}\Omega$	
V_{OL}	Logical "0" Output Voltage	$V_{SS} = \text{Min}$	Osc	$V_{RC} = 1.6\text{V}$				0.5	V
			Pin R						$I_{OL} = 6 \text{ mA}$
		$V_{SS} = \text{Max}$	Digit Output	$V_{ENABLE} = 1\text{V}$	$I_{OL} = 10 \mu\text{A}$			$V_{BB} + 1.4$	V
I_{SS}	Supply Current	$V_{SS} = 9.5\text{V}$, $I_{OH} = 0$	$V_{ENABLE} = 5.1\text{V}$			9.0	12.5	mA	
			$V_{ENABLE} = 1\text{V}$			5.0	9.0	mA	
I_{BB}	Supply Current	$V_{SS} = 9.5\text{V}$, $I_B = 0$, $V_{BB} = -26\text{V}$, $I_{IN} = 300 \mu\text{A}$ (Note 4)	$V_{ENABLE} = 1\text{V}$			-0.8	-1.5	mA	
			$V_{ENABLE} = 5.1\text{V}$			-3.0	-5.0	mA	
V_B	Filament Bias Voltage	$I_B = 10 \text{ mA}$			$V_{BB} + 6.4$	$V_{BB} + 6.9$	$V_{BB} + 7.4$	V	

Note 1: "Absolute Maximum Ratings" are those values beyond which the safety of the device cannot be guaranteed. They are not meant to imply that the devices should be operated at these limits. The table of "Electrical Characteristics" provides conditions for actual device operation.

Note 2: Unless otherwise specified, min/max limits apply across the 0°C to +70°C range. All typicals are given for $T_A = 25^\circ\text{C}$.

Note 3: All currents into device pins shown as positive, out of device pins as negative, and all voltages referenced to ground unless otherwise noted. All values shown as max or min on absolute value basis.

Note 4: Approximately 50% of input current on pins 4, 5, 6, 7 is shunted to V_{BB} . If minimum I_{BB} is desired, then I_{IN} should be minimized by using resistors in series with the inputs.

Switching Characteristics $T_A = 25^\circ\text{C}$ unless otherwise specified

Symbol	Parameter	Conditions	Min	Typ	Max	Units
t_{pd0}	Propagation Delay to a Logical "0" from Enable Input to Digit Output	$R_L = 4.7\text{ k}\Omega, C_L = 50\text{ pF}, V_{BB} = -23\text{V}, V_{SS} = 8\text{V}$			1	μs
t_{pd0}	Propagation Delay to a Logical "0" A, B, C, D to Digit Output				1	μs
t_{pd1}	Propagation Delay to a Logical "1" from Enable Input to Digit Output				300	ns
t_{pd1}	Propagation Delay to a Logical "1" from A, B, C, D to Digit Output				500	ns
t_{FALL}	Oscillator Output Transition Time from 1 to 0	$V_{SS} = 9.5\text{V}, R_L = 6\text{ k}\Omega \text{ to } V_{SS}, C_L = 25\text{ pF}$			50	ns
f_{OSC}	Oscillator Frequency	$7\text{V} < V_{SS} < 9.5\text{V}, R_T = 27\text{ k}\Omega \pm 2\%, R_L = 1.3\text{k}, C_T = 100\text{ pF}, \pm 5\%, C_L = 50\text{ pF}$	320	360	400	kHz
dc	Oscillator Duty Cycle		46	56	66	%

AC Test Circuit

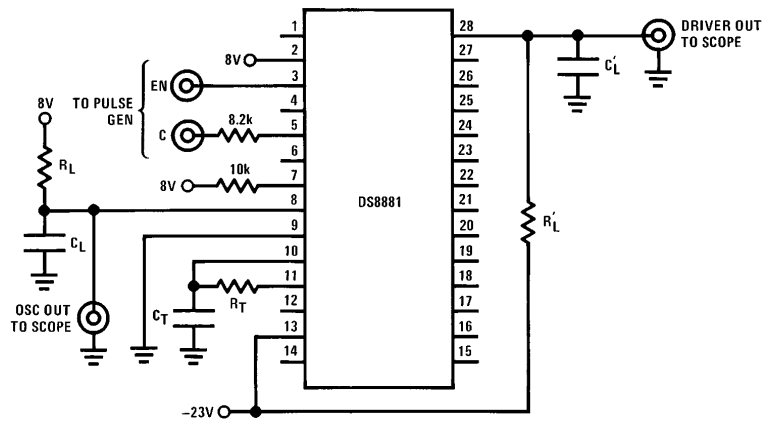

TL/F/5846-2

Switching Time Waveforms

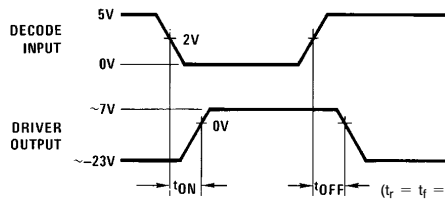
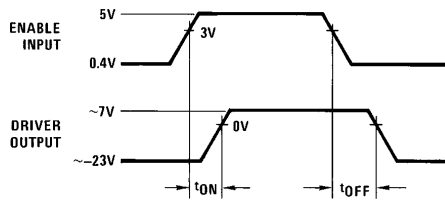

($t_r = t_f = 10$ ns from 10% to 90% of input)

TL/F/5846-3

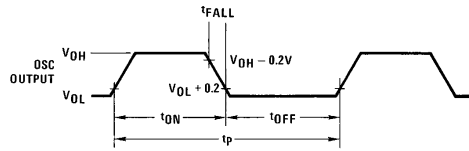

TL/F/5846-4

$$\text{Duty Cycle} = \frac{t_{ON}}{t_p}$$

$$\text{Frequency} = \frac{1}{t_p}$$

Input-Output Schematics

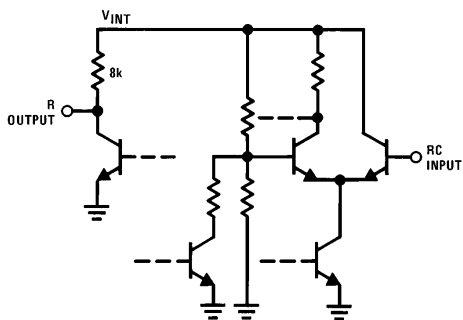

TL/F/5846-5

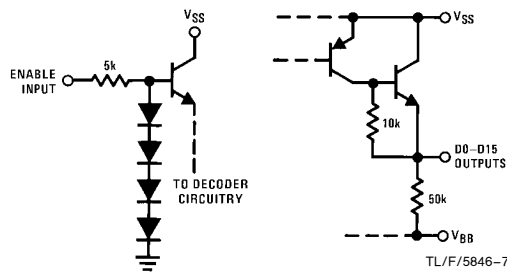

TL/F/5846-6

TL/F/5846-7

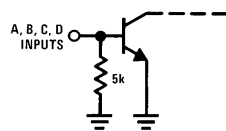

TL/F/5846-8

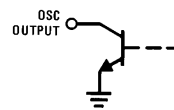

TL/F/5846-9

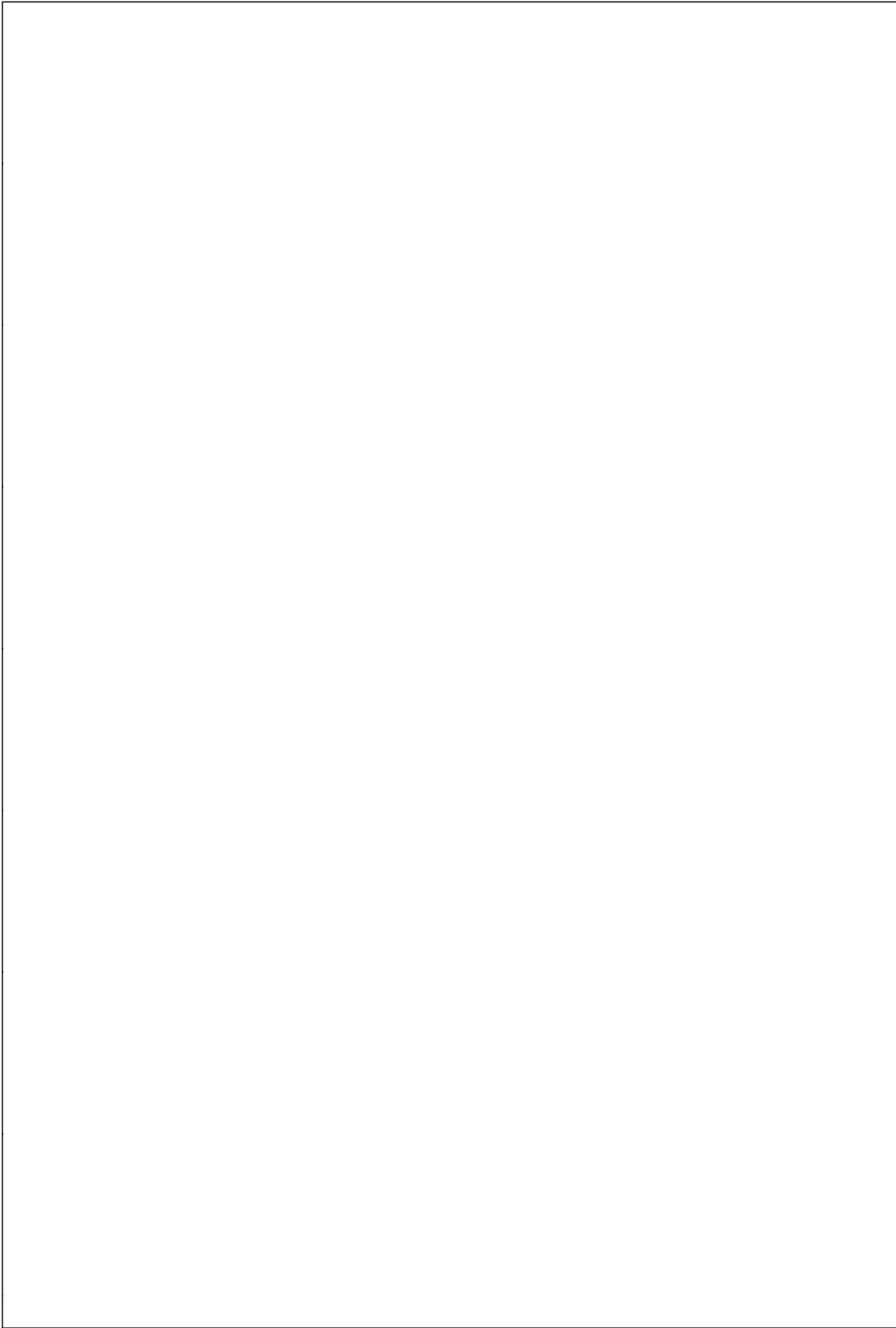

DS8881 Vacuum Fluorescent Display Driver

Physical Dimensions inches (millimeters)

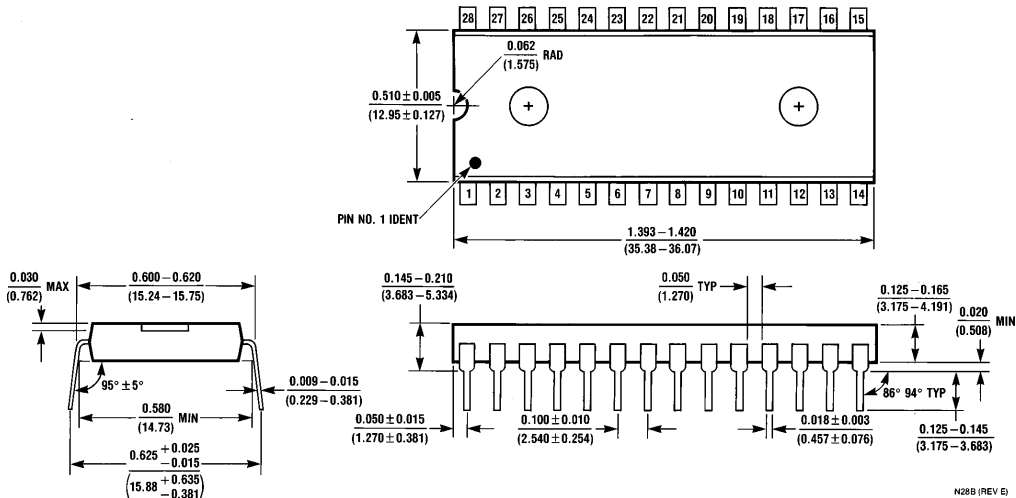

Molded Dual-In-Line Package (N)
Order Number DS8881N
NS Package Number N28B

LIFE SUPPORT POLICY

NATIONAL'S PRODUCTS ARE NOT AUTHORIZED FOR USE AS CRITICAL COMPONENTS IN LIFE SUPPORT DEVICES OR SYSTEMS WITHOUT THE EXPRESS WRITTEN APPROVAL OF THE PRESIDENT OF NATIONAL SEMICONDUCTOR CORPORATION. As used herein:

1. Life support devices or systems are devices or systems which, (a) are intended for surgical implant into the body, or (b) support or sustain life, and whose failure to perform, when properly used in accordance with instructions for use provided in the labeling, can be reasonably expected to result in a significant injury to the user.
2. A critical component is any component of a life support device or system whose failure to perform can be reasonably expected to cause the failure of the life support device or system, or to affect its safety or effectiveness.



National Semiconductor Corporation
 1111 West Bardin Road
 Arlington, TX 76017
 Tel: 1(800) 272-9959
 Fax: 1(800) 737-7018

National Semiconductor Europe
 Fax: (+49) 0-180-530 85 86
 Email: onjwge@tevm2.nsc.com
 Deutsch Tel: (+49) 0-180-530 85 85
 English Tel: (+49) 0-180-532 78 32
 Français Tel: (+49) 0-180-532 93 58
 Italiano Tel: (+49) 0-180-534 16 80

National Semiconductor Hong Kong Ltd.
 19th Floor, Straight Block,
 Ocean Centre, 5 Canton Rd.
 Tsimshatsui, Kowloon
 Hong Kong
 Tel: (852) 2737-1600
 Fax: (852) 2736-9960

National Semiconductor Japan Ltd.
 Tel: 81-043-299-2309
 Fax: 81-043-299-2408

National Semiconductor was acquired by Texas Instruments.

http://www.ti.com/corp/docs/investor_relations/pr_09_23_2011_national_semiconductor.html

This file is the datasheet for the following electronic components:

DS8881 - <http://www.ti.com/product/ds8881?HQS=TI-null-null-dscatalog-df-pf-null-ww>



LittleDiode supplies new, hard to find or obsolete electronic components and semiconductors all over the world.

With over two million different components listed you are sure to find the part you need.

Feel free to visit us today at our online store:

LittleDiode.com

Looking forward to providing you with the best possible service.