

Quad 2-input NOR gate

BU4001B / BU4001BF

The BU4001B and BU4001BF are 2-input positive logic NOR gates, each with four built-in circuits. A buffer achieved by an inverter added at the gate output improves the input / output propagation characteristic and minimizes variation in the propagation time caused by increase of the load capacitance.

●Features

- 1) Low power dissipation.
- 2) Wide range of operating power supply voltage.
- 3) High input impedance.
- 4) High fan-out.
- 5) Direct drive of 2 L-TTL inputs and 1 LS-TTL input.

●Block diagram

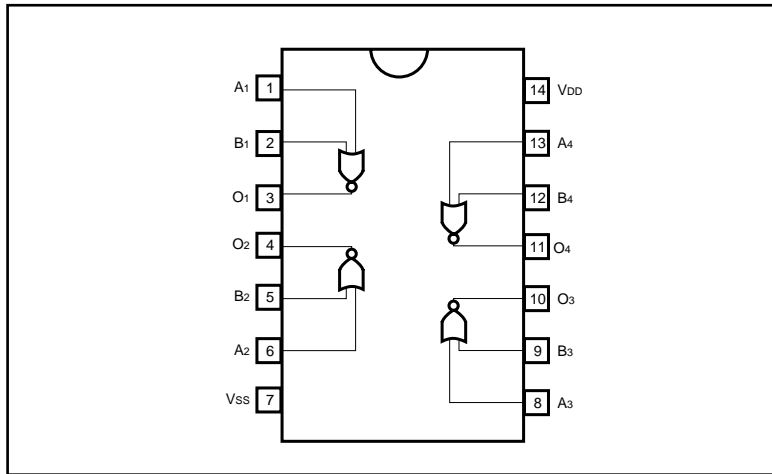

●Absolute maximum ratings ($V_{SS} = 0V$, $T_a = 25^{\circ}C$)

Parameter	Symbol	Limits	Unit
Power supply voltage	V_{DD}	- 0.3 ~ + 18	V
Power dissipation	P_d	1000 (DIP), 450 (SOP)	mW
Operating temperature	T_{opr}	- 40 ~ + 85	$^{\circ}C$
Storage temperature	T_{stg}	- 55 ~ + 150	$^{\circ}C$
Input voltage	V_{IN}	- 0.3 ~ $V_{DD} + 0.3$	V

●Electrical characteristics

DC characteristics (unless otherwise noted, $V_{SS} = 0V$, $T_a = 25^\circ C$)

Parameter	Symbol	Min.	Typ.	Max.	Unit	V _{DD} (V)	Conditions	Measurement circuit
Input high level voltage	V _{IH}	3.5	—	—	V	5	—	Fig.1
		7.0	—	—		10		
		11.0	—	—		15		
Input low level voltage	V _{IL}	—	—	1.5	V	5	—	Fig.1
		—	—	3.0		10		
		—	—	4.0		15		
Input high level current	I _{IH}	—	—	0.3	μA	15	V _{IH} = 15V	Fig.1
Input low level current	I _{IL}	—	—	- 0.3	μA	15	V _{IL} = 0V	Fig.1
Output high level voltage	V _{OH}	4.95	—	—	V	5	I _O = 0mA	Fig.1
		9.95	—	—		10		
		14.95	—	—		15		
Output low level voltage	V _{OL}	—	—	0.05	V	5	I _O = 0mA	Fig.1
		—	—	0.05		10		
		—	—	0.05		15		
Output high level current	I _{OH}	- 0.16	—	—	mA	5	V _{OH} = 4.6V	Fig.1
		- 0.4	—	—		10	V _{OH} = 9.5V	
		- 1.2	—	—		15	V _{OH} = 13.5V	
Output low level current	I _{OL}	0.44	—	—	mA	5	V _{OL} = 0.4V	Fig.1
		1.1	—	—		10	V _{OL} = 0.5V	
		3.0	—	—		15	V _{OL} = 1.5V	
Static current dissipation	I _{DD}	—	—	1	μA	5	V _I = V _{DD} or GND	—
		—	—	2		10		
		—	—	4		15		

Switching characteristics (unless otherwise noted, $V_{SS} = 0V$, $T_a = 25^\circ C$, $C_L = 50pF$)

Parameter	Symbol	Min.	Typ.	Max.	Unit	V _{DD} (V)	Conditions	Measurement circuit
						5		
Output rise time	t _{TLH}	—	180	—	ns	5	—	Fig.2
		—	90	—		10		
		—	65	—		15		
Output fall time	t _{THL}	—	100	—	ns	5	—	Fig.2
		—	50	—		10		
		—	40	—		15		
Propagation delay time, "L" to "H"	t _{PLH}	—	90	—	ns	5	—	Fig.2
		—	50	—		10		
		—	40	—		15		
Propagation delay time, "H" to "L"	t _{PHL}	—	90	—	ns	5	—	Fig.2
		—	50	—		10		
		—	40	—		15		
Input capacitance	C _{IN}	—	5	—	pF	—	—	—

●Measurement circuits

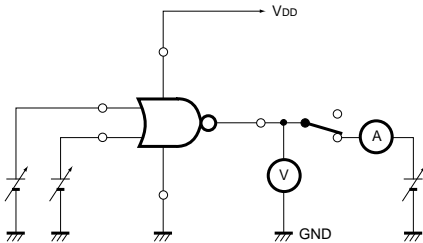

Fig.1 DC characteristics

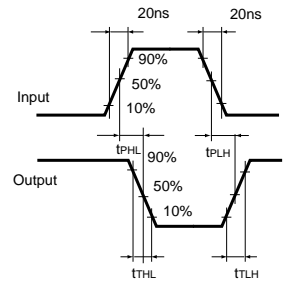
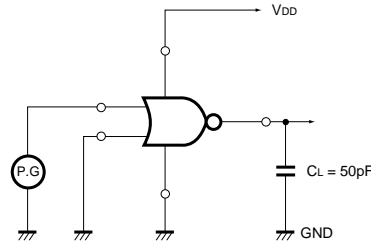

Fig.2 Switching characteristics

●Electrical characteristic curve

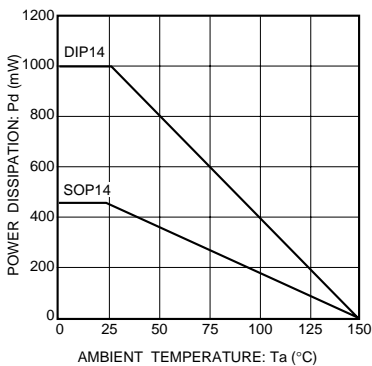
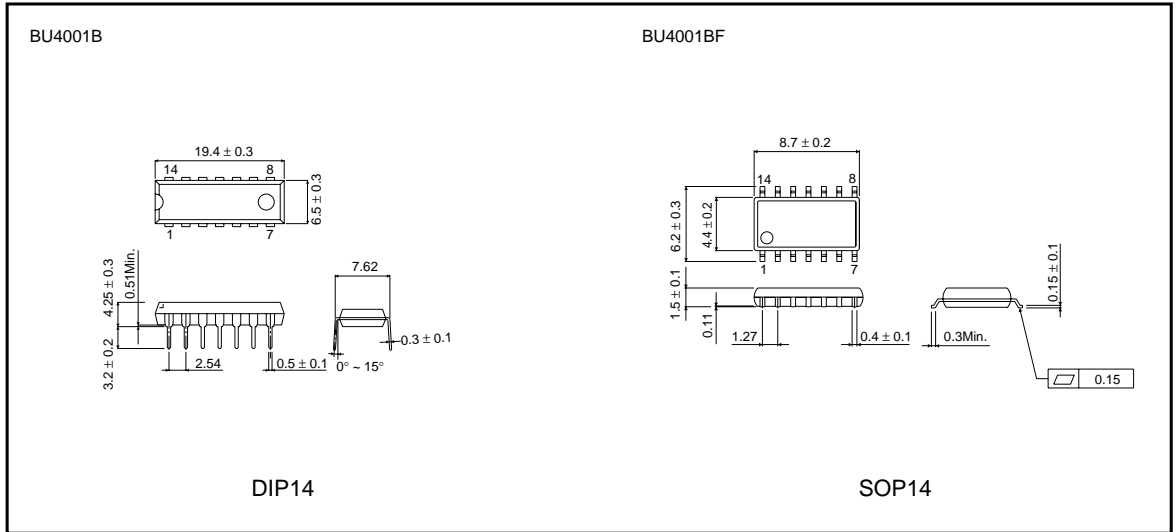

Fig.3 Power dissipation vs. Ta characteristic

●External dimensions (Units: mm)



This datasheet has been downloaded from:

www.DatasheetCatalog.com

Datasheets for electronic components.



LittleDiode supplies new, hard to find or obsolete electronic components and semiconductors all over the world.

With over two million different components listed you are sure to find the part you need.

Feel free to visit us today at our online store:

LittleDiode.com

Looking forward to providing you with the best possible service.