

**HIGH VOLTAGE IGNITION COIL DRIVER
NPN POWER DARLINGTON**

PRELIMINARY DATA

- VERY RUGGED BIPOLAR TECHNOLOGY
- HIGH OPERATING JUNCTION TEMPERATURE
- WIDE RANGE OF PACKAGES
- POWER PACKAGE SPECIFICALLY DESIGNED FOR SURFACE MOUNTING (Power SO-10™)

APPLICATIONS

- HIGH RUGGEDNESS ELECTRONIC IGNITIONS

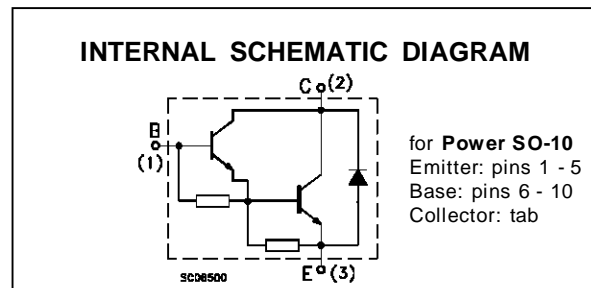
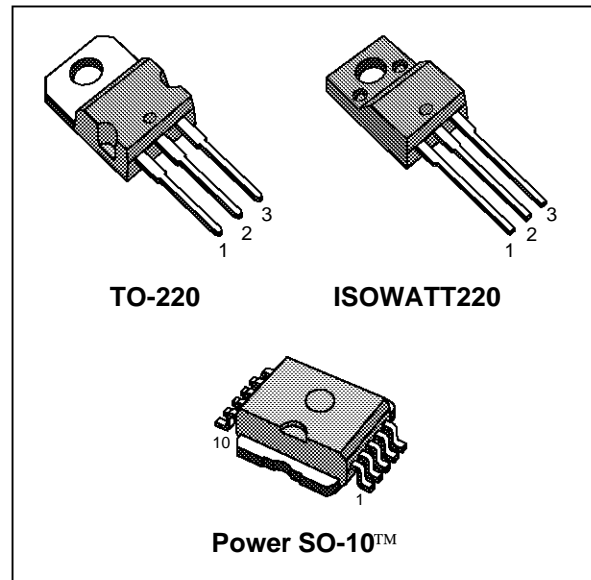

ABSOLUTE MAXIMUM RATINGS

Symbol	Parameter	Value			Unit
		BU941T	BU941TFI	BU941SM	
V _{CES}	Collector-Emitter Voltage (V _{BE} = 0)	500			V
V _{CEO}	Collector-Emitter Voltage (I _B = 0)	400			V
V _{EBO}	Emitter-Base Voltage (I _C = 0)	5			V
I _C	Collector Current	15			A
I _{CM}	Collector Peak Current	30			A
I _B	Base Current	1			A
I _{BM}	Base Peak Current	5			A
P _{tot}	Total Dissipation at T _c = 25 °C	150	55	150	W
T _{stg}	Storage Temperature	-65 to 175	-65 to 175	-65 to 175	°C
T _j	Max. Operating Junction Temperature	175	175	175	°C

BU941T/BU941TFI/BU941SM

THERMAL DATA

		TO-220	ISOWATT220	PowerSO-10	
$R_{thj-case}$	Thermal Resistance Junction-case Max	1	2.7	1	°C/W

ELECTRICAL CHARACTERISTICS ($T_{case} = 25\text{ }^{\circ}\text{C}$ unless otherwise specified)

Symbol	Parameter	Test Conditions	Min.	Typ.	Max.	Unit
I_{CES}	Collector Cut-off Current ($V_{BE} = 0$)	$V_{CE} = 500\text{ V}$ $V_{CE} = 500\text{ V}$ $T_j = 125\text{ }^{\circ}\text{C}$			100 0.5	μA mA
I_{CEO}	Collector Cut-off Current ($I_B = 0$)	$V_{CE} = 450\text{ V}$ $V_{CE} = 450\text{ V}$ $T_j = 125\text{ }^{\circ}\text{C}$			100 0.5	μA mA
I_{EBO}	Emitter Cut-off Current ($I_C = 0$)	$V_{EB} = 5\text{ V}$			20	mA
$V_{CEO(SUS)*}$	Collector-Emitter Saturation Voltage	$I_C = 100\text{ mA}$ $L = 10\text{ mH}$ $I_B = 0$ $V_{CLAMP} = \text{RATED } V_{CEO}$ (See FIG.4)	400			V
$V_{CE(sat)*}$	Collector-Emitter Saturation Voltage	$I_C = 8\text{ A}$ $I_B = 100\text{ mA}$ $I_C = 10\text{ A}$ $I_B = 250\text{ mA}$			1.6 1.8	V V
$V_{BE(sat)*}$	Base-Emitter Saturation Voltage	$I_C = 8\text{ A}$ $I_B = 100\text{ mA}$ $I_C = 10\text{ A}$ $I_B = 250\text{ mA}$			2.2 2.5	V V
h_{FE*}	DC Current Gain	$I_C = 5\text{ A}$ $V_{CE} = 10\text{ V}$	300			
V_F	Diode Forward Voltage	$I_F = 10\text{ A}$			2.5	V
	Functional Test (see fig. 1)	$V_{CC} = 24\text{ V}$ $V_{clamp} = 400\text{ V}$ $L = 7\text{ mH}$	10			A
t_s t_f	INDUCTIVE LOAD Storage Time Fall Time (see fig. 3)	$V_{CC} = 12\text{ V}$ $V_{clamp} = 300\text{ V}$ $L = 7\text{ mH}$ $I_C = 7\text{ A}$ $I_B = 70\text{ mA}$ $V_{BE} = 0$ $R_{BE} = 47\text{ }\Omega$		15 0.5		μs μs

* Pulsed: Pulse duration = 300 μs , duty cycle 1.5 %

Safe Operating Areas

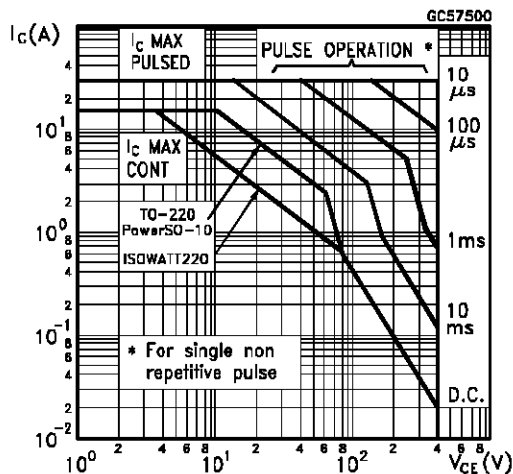

DC Current Gain

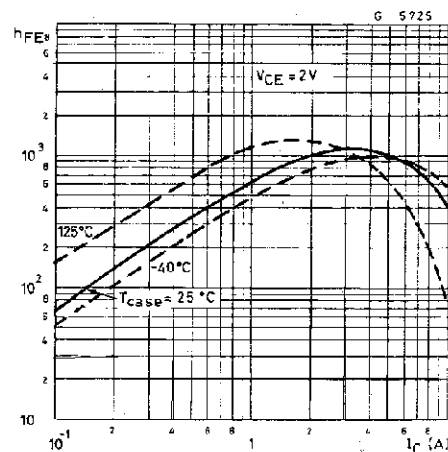

DC Current Gain

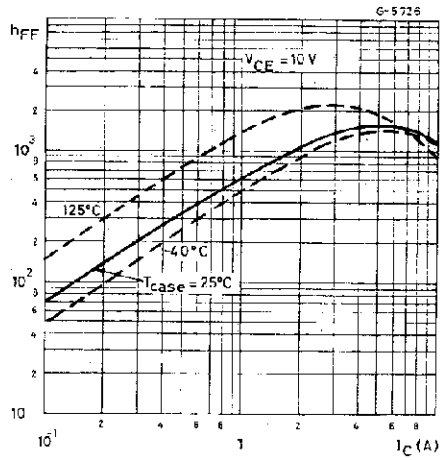

Collector-emitter Saturation Voltage

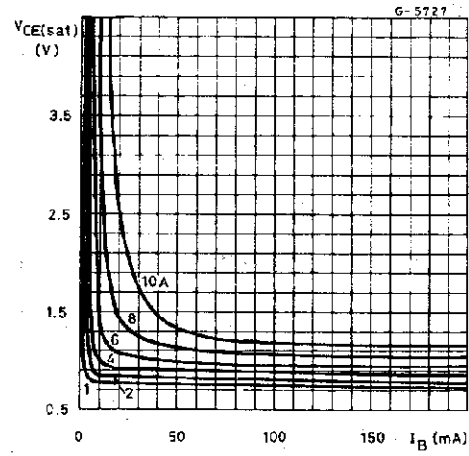

Collector-emitter Saturation Voltage

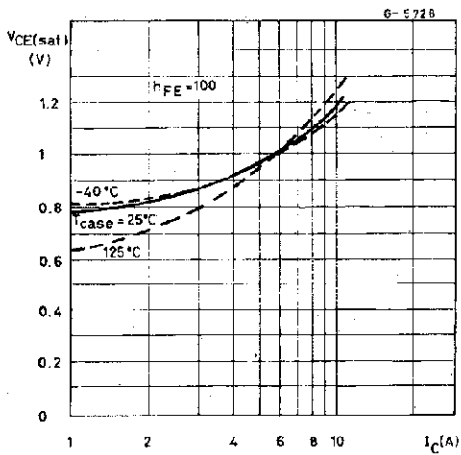

Base-emitter Saturation Voltage

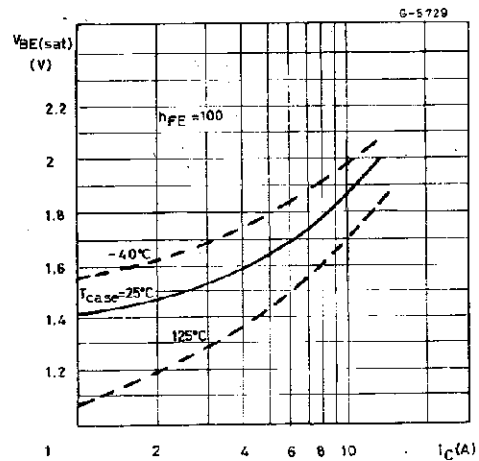

Switching Times Inductive Load (see fig. 3)

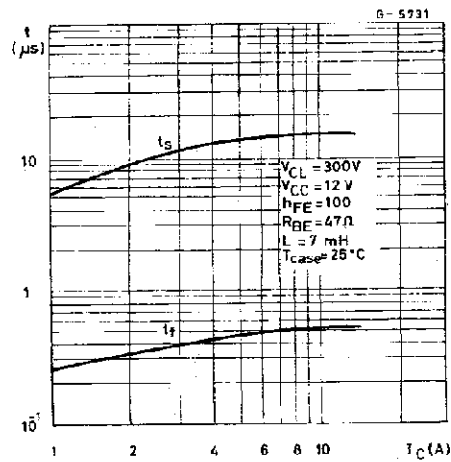

FIGURE 1: Functional Test Circuit

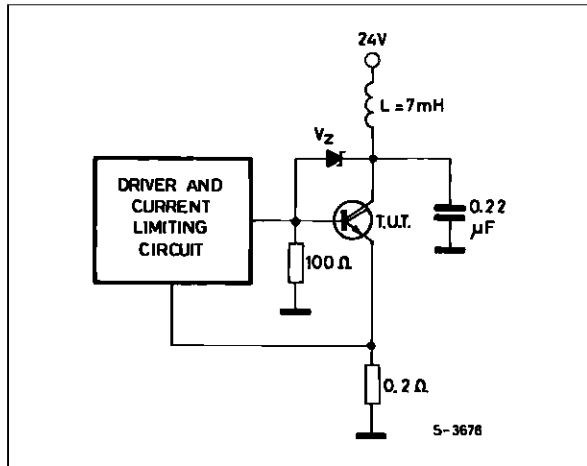

FIGURE 2: Functional Test Waveforms

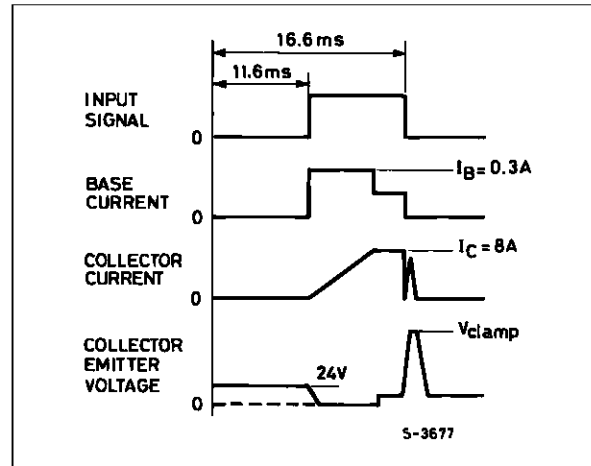

FIGURE 3: Switching Time Test Circuit

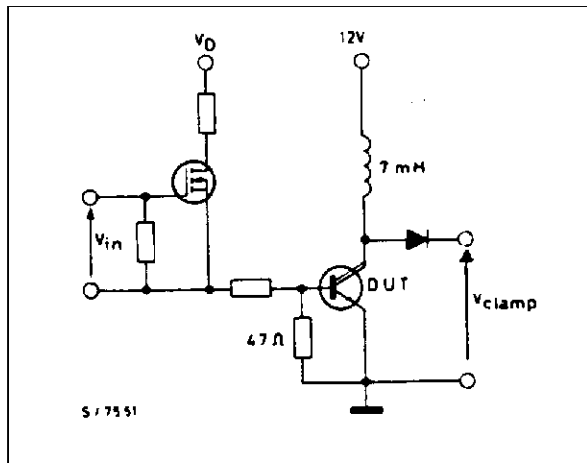
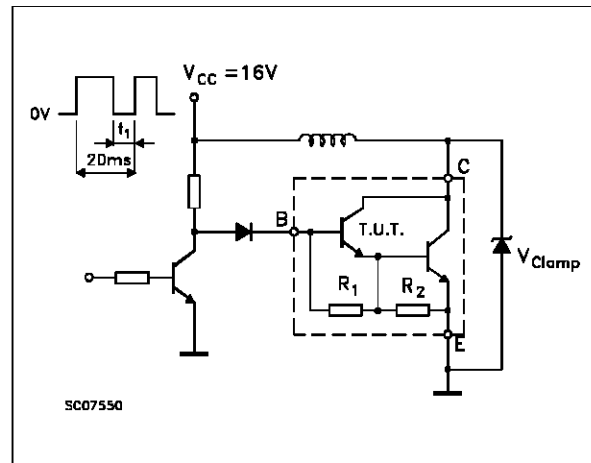
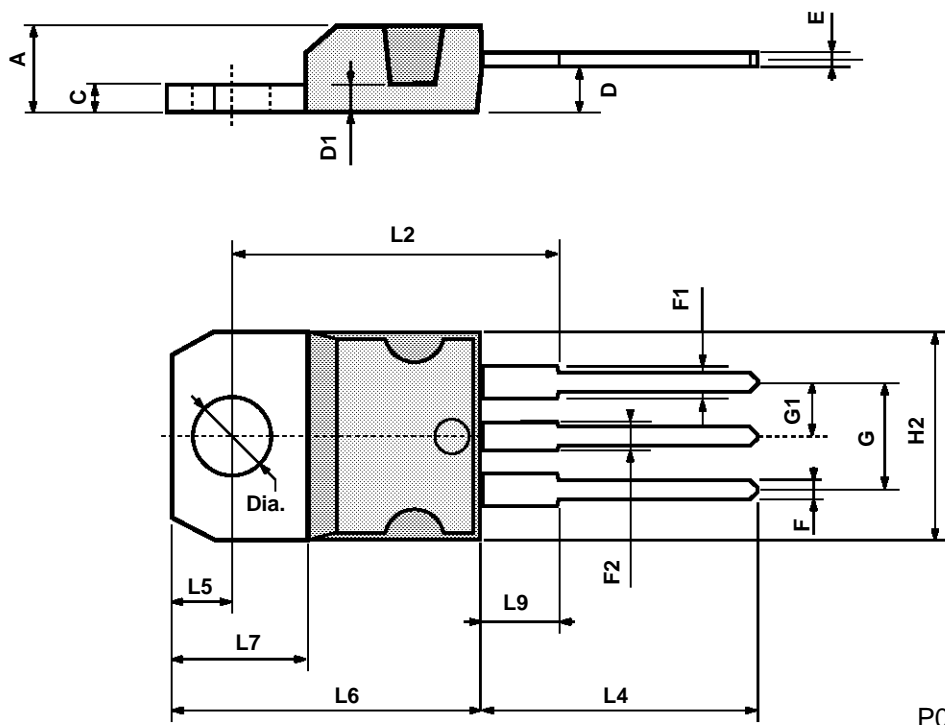

FIGURE 4: Sustaining Voltage Test Circuit



TO-220 MECHANICAL DATA

DIM.	mm			inch		
	MIN.	TYP.	MAX.	MIN.	TYP.	MAX.
A	4.40		4.60	0.173		0.181
C	1.23		1.32	0.048		0.051
D	2.40		2.72	0.094		0.107
D1		1.27			0.050	
E	0.49		0.70	0.019		0.027
F	0.61		0.88	0.024		0.034
F1	1.14		1.70	0.044		0.067
F2	1.14		1.70	0.044		0.067
G	4.95		5.15	0.194		0.203
G1	2.4		2.7	0.094		0.106
H2	10.0		10.40	0.393		0.409
L2		16.4			0.645	
L4	13.0		14.0	0.511		0.551
L5	2.65		2.95	0.104		0.116
L6	15.25		15.75	0.600		0.620
L7	6.2		6.6	0.244		0.260
L9	3.5		3.93	0.137		0.154
DIA.	3.75		3.85	0.147		0.151



ISOWATT220 MECHANICAL DATA

DIM.	mm			inch		
	MIN.	TYP.	MAX.	MIN.	TYP.	MAX.
A	4.4		4.6	0.173		0.181
B	2.5		2.7	0.098		0.106
D	2.5		2.75	0.098		0.108
E	0.4		0.7	0.015		0.027
F	0.75		1	0.030		0.039
F1	1.15		1.7	0.045		0.067
F2	1.15		1.7	0.045		0.067
G	4.95		5.2	0.195		0.204
G1	2.4		2.7	0.094		0.106
H	10		10.4	0.393		0.409
L2		16			0.630	
L3	28.6		30.6	1.126		1.204
L4	9.8		10.6	0.385		0.417
L6	15.9		16.4	0.626		0.645
L7	9		9.3	0.354		0.366
∅	3		3.2	0.118		0.126

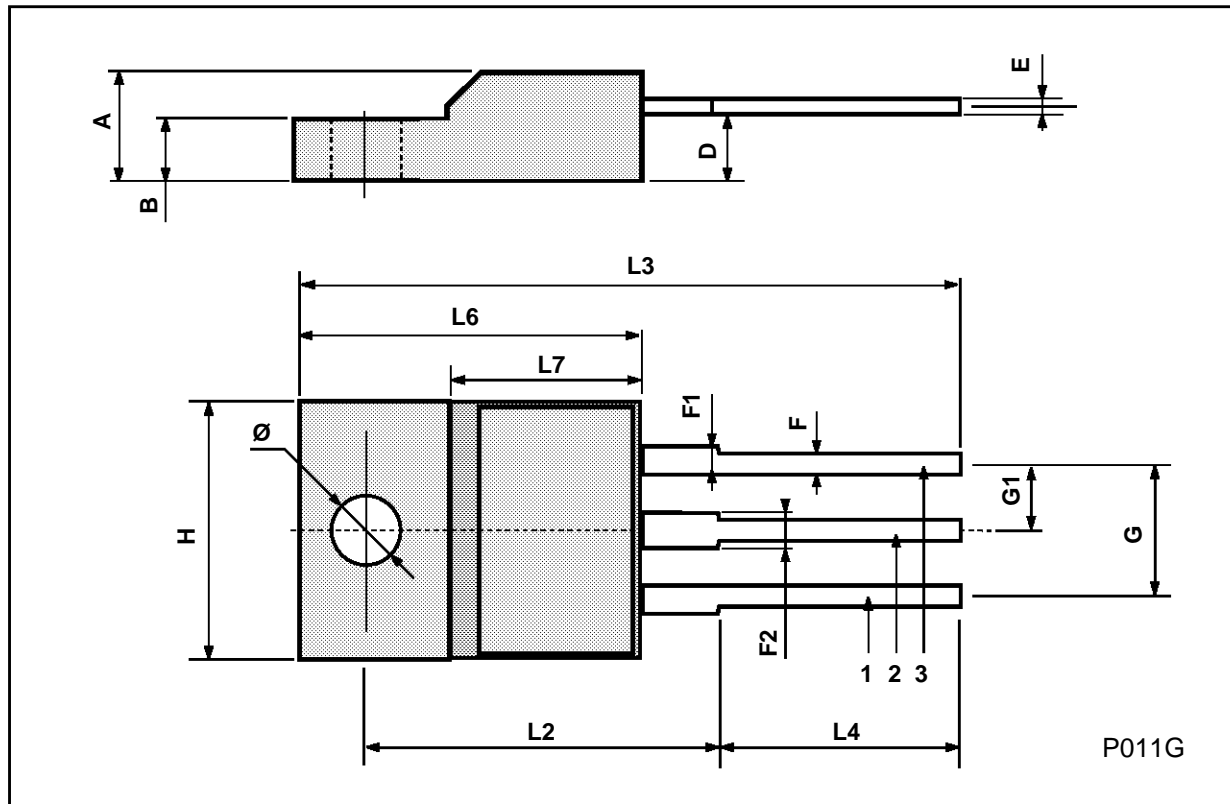

Power SO-10 MECHANICAL DATA

DIM.	mm			inch		
	MIN.	TYP.	MAX.	MIN.	TYP.	MAX.
A	3.45	3.5	3.55	0.135	0.137	0.140
B		1.28	1.30		0.050	0.051
C			0.15			0.006
D	9.40	9.50	9.60	0.370	0.374	0.378
E	4.98	5.08	5.48	0.196	0.200	0.216
E1	0.40	0.45	0.60	0.016	0.018	0.024
E2	1.17	1.27	1.37	0.046	0.050	0.054
F	9.30	9.40	9.50	0.366	0.370	0.374
F1	7.95	8.00	8.15	0.313	0.315	0.321
G	7.40	7.50	7.60	0.291	0.295	0.299
H	6.80	6.90	7.00	0.267	0.417	0.421
I		0.10			0.004	
K	13.80	14.10	14.40	0.543	0.555	0.567
L		0.40	0.50		0.016	0.020
M	1.60	1.67	1.80	0.063	0.066	0.071
N	0.60	0.08	1.00	0.024	0.031	0.039

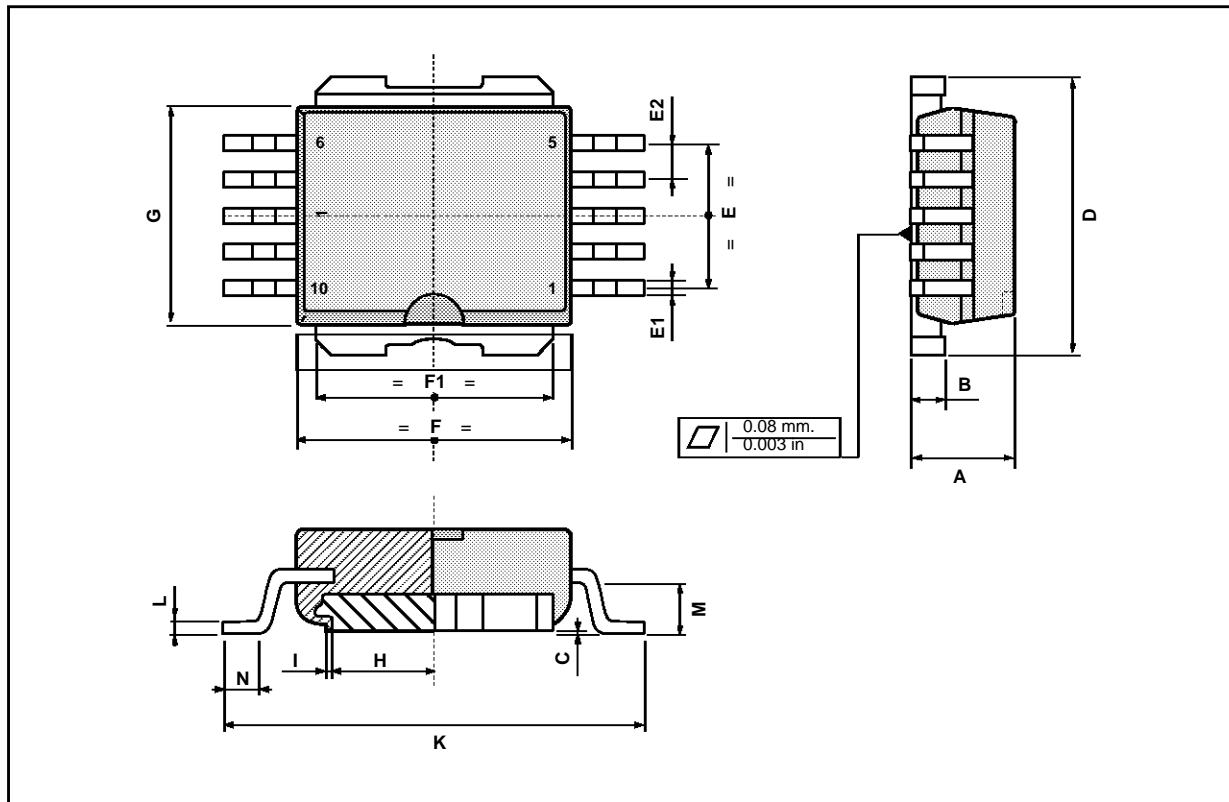

Information furnished is believed to be accurate and reliable. However, SGS-THOMSON Microelectronics assumes no responsibility for the consequences of use of such information nor for any infringement of patents or other rights of third parties which may result from its use. No license is granted by implication or otherwise under any patent or patent rights of SGS-THOMSON Microelectronics. Specifications mentioned in this publication are subject to change without notice. This publication supersedes and replaces all information previously supplied. SGS-THOMSON Microelectronics products are not authorized for use as critical components in life support devices or systems without express written approval of SGS-THOMSON Microelectronics.

© 1994 SGS-THOMSON Microelectronics - All Rights Reserved

SGS-THOMSON Microelectronics GROUP OF COMPANIES
Australia - Brazil - France - Germany - Hong Kong - Italy - Japan - Korea - Malaysia - Malta - Morocco - The Netherlands -
Singapore - Spain - Sweden - Switzerland - Taiwan - Thailand - United Kingdom - U.S.A