

DS25BR400

Quad 2.5 Gbps CML Transceiver with Transmit De-Emphasis and Receive Equalization

General Description

The DS25BR400 is a quad 250 Mbps – 2.5 Gbps CML transceiver, or 8-channel buffer, for use in backplane and cable applications. With operation down to 250 Mbps, the DS25BR400 can be used in applications requiring both low and high frequency data rates. Each input stage has a fixed equalizer to reduce ISI distortion from board traces. The equalizers are enabled through two control pins. These control pins provide flexibility in applications where ISI distortion may vary from one direction to another. All output drivers have four selectable steps of de-emphasis to compensate for transmission loss. The de-emphasis blocks are also grouped in fours. In addition, the DS25BR400 also has loopback control capability on four channels. All the CML drivers have 50Ω termination to V_{cc}. All receivers are internally terminated with differential 100Ω.

Features

- 250 Mbps – 2.5 Gbps low jitter operation
- Optional Fixed Input Equalization
- Selectable Output De-emphasis
- Individual Loopback Controls
- On-chip Termination
- +3.3V supply
- Lead-less eLLP-60 pin package (9mmx9mmx0.8mm, 0.5mm pitch)
- –40°C to +85°C Industrial Temperature Range
- 6 kV ESD Rating, HBM

Applications

- Backplane or cable driver
- Signal buffering and repeating

Simplified Application Diagram

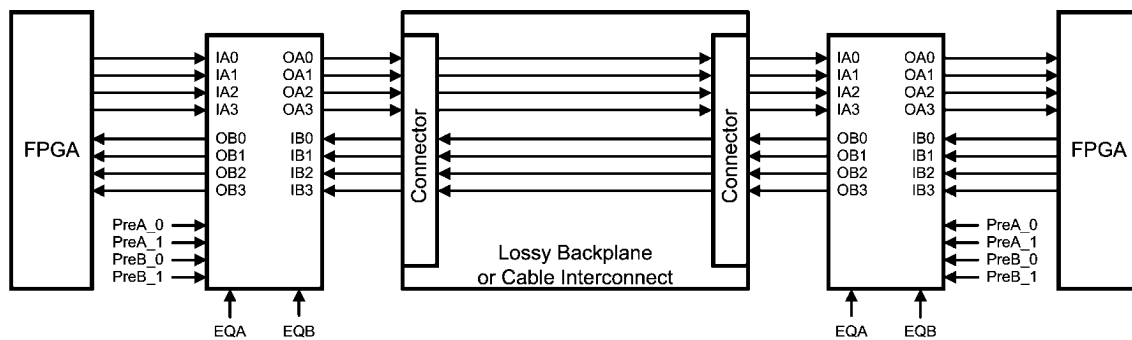

20194240

Functional Block Diagram

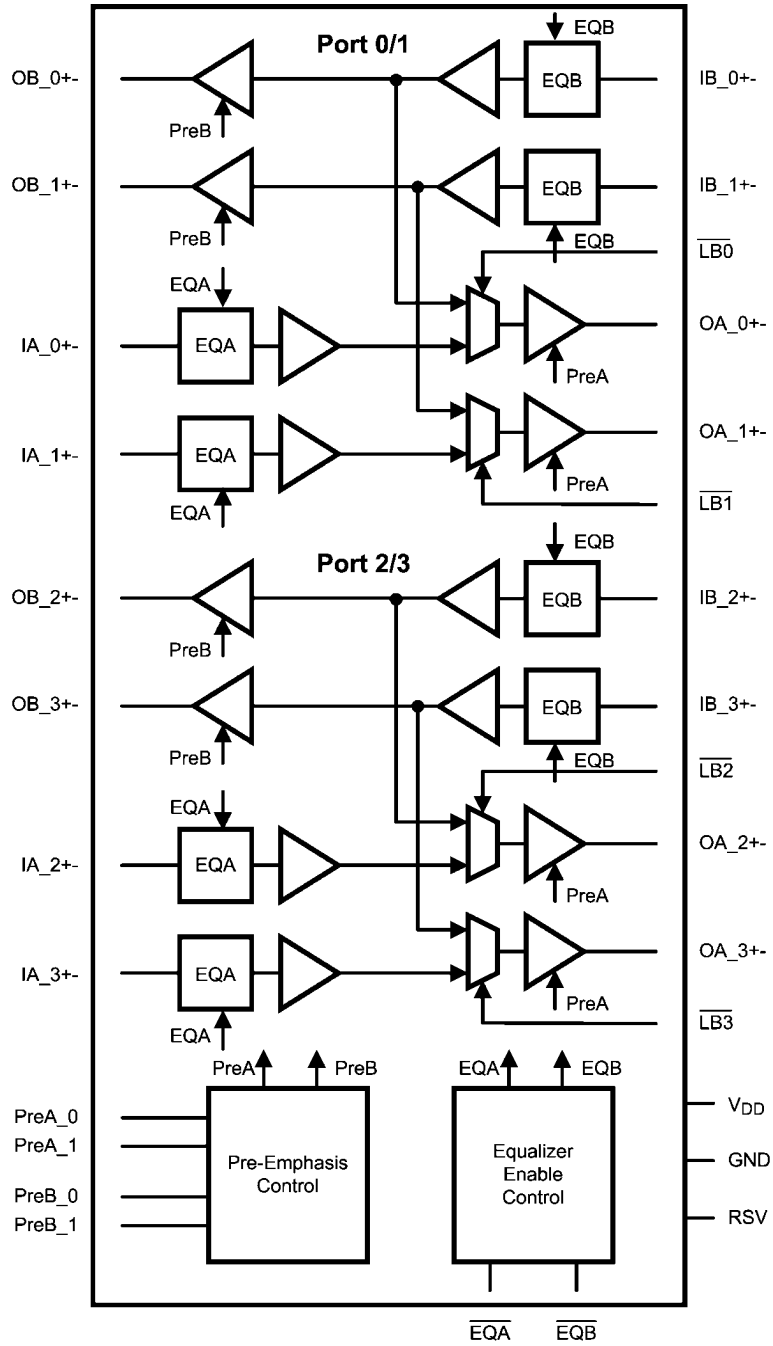

20194201

Connection Diagram

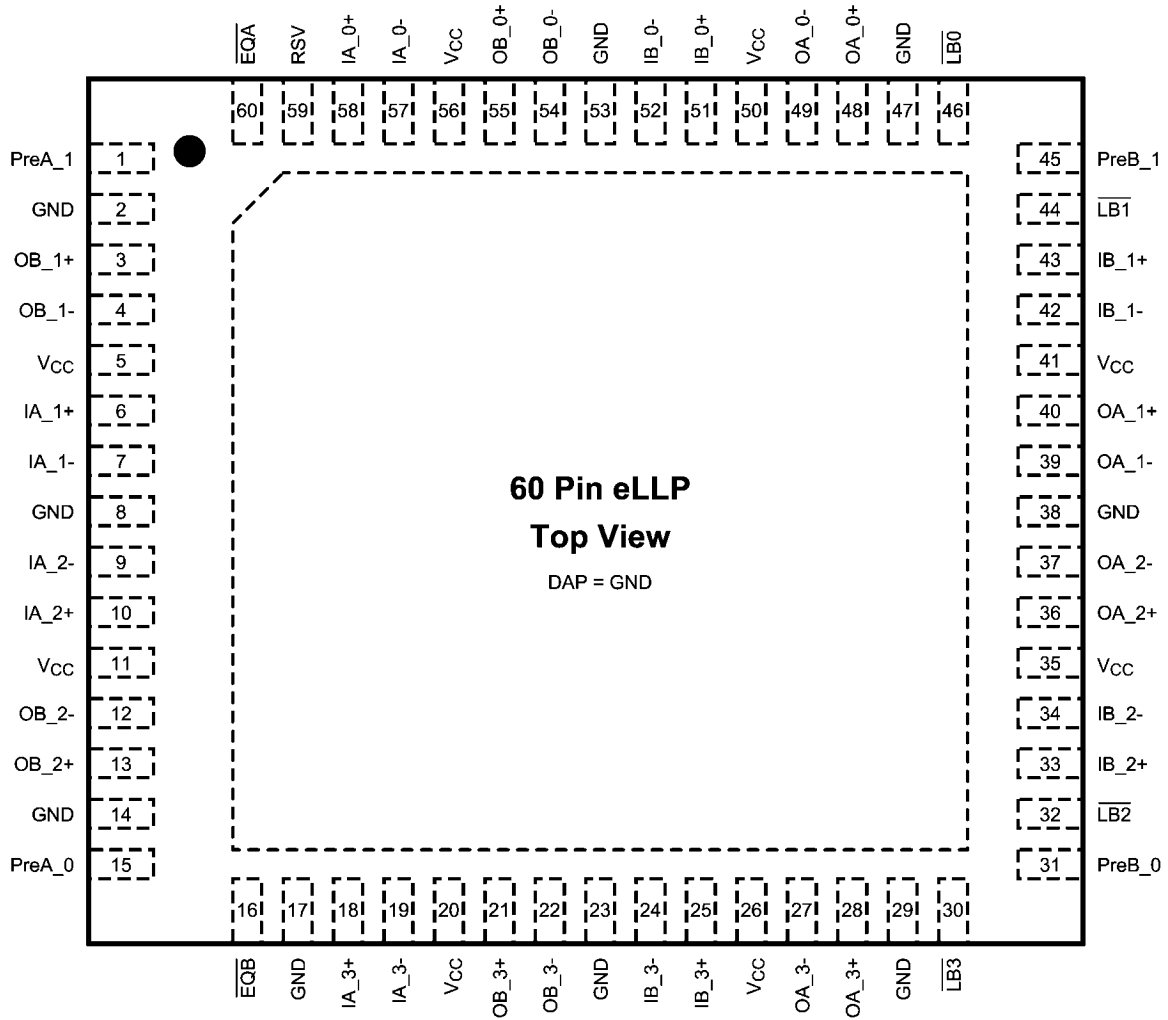

Leadless eLLP-60 Pin Package
(9 mmx9 mmx0.8 mm, 0.5 mm pitch)
Order number DS25BR400TSQ
See NS Package Number SQA060

20194202

Pin Descriptions

Pin Name	Pin Number	I/O	Description
DIFFERENTIAL I/O			
IB_0+	51	I	Inverting and non-inverting differential inputs of port_0. IB_0+ and IB_0– are internally connected to a reference voltage through a 50Ω resistor. Refer to <i>Figure 7</i>
IB_0–	52		
OA_0+	48	O	Inverting and non-inverting differential outputs of port_0. OA_0+ and OA_0– are connected to V _{CC} through a 50Ω resistor.
OA_0–	49		
IB_1+	43	I	Inverting and non-inverting differential inputs of port_1. IB_1+ and IB_1– are internally connected to a reference voltage through a 50Ω resistor. Refer to <i>Figure 7</i>
IB_1–	42		
OA_1+	40	O	Inverting and non-inverting differential outputs of port_1. OA_1+ and OA_1– are connected to V _{CC} through a 50Ω resistor.
OA_1–	39		
IB_2+	33	I	Inverting and non-inverting differential inputs of port_2. IB_2+ and IB_2– are internally connected to a reference voltage through a 50Ω resistor. Refer to <i>Figure 7</i>
IB_2–	34		
OA_2+	36	O	Inverting and non-inverting differential outputs of port_2. OA_2+ and OA_2– are connected to V _{CC} through a 50Ω resistor.
OA_2–	37		
IB_3+	25	I	Inverting and non-inverting differential inputs of port_3. IB_3+ and IB_3– are internally connected to a reference voltage through a 50Ω resistor. Refer to <i>Figure 7</i>
IB_3–	24		
OA_3+	28	O	Inverting and non-inverting differential outputs of port_3. OA_3+ and OA_3– are connected to V _{CC} through a 50Ω resistor.
OA_3–	27		
IA_0+	58	I	Inverting and non-inverting differential inputs of port_0. IA_0+ and IA_0– are internally connected to a reference voltage through a 50Ω resistor. Refer to <i>Figure 7</i>
IA_0–	57		
OB_0+	55	O	Inverting and non-inverting differential outputs of port_0. OB_0+ and OB_0– are connected to V _{CC} through a 50Ω resistor.
OB_0–	54		
IA_1+	6	I	Inverting and non-inverting differential inputs of port_1. IA_1+ and IA_1– are internally connected to a reference voltage through a 50Ω resistor. Refer to <i>Figure 7</i>
IA_1–	7		
OB_1+	3	O	Inverting and non-inverting differential outputs of port_1. OB_1+ and OB_1– are connected to V _{CC} through a 50Ω resistor.
OB_1–	4		
IA_2+	10	I	Inverting and non-inverting differential inputs of port_2. IA_2+ and IA_2– are internally connected to a reference voltage through a 50Ω resistor. Refer to <i>Figure 7</i>
IA_2–	9		
OB_2+	13	O	Inverting and non-inverting differential outputs of port_2. OB_2+ and OB_2– are connected to V _{CC} through a 50Ω resistor.
OB_2–	12		
IA_3+	18	I	Inverting and non-inverting differential inputs of port_3. IA_3+ and IA_3– are internally connected to a reference voltage through a 50Ω resistor. Refer to <i>Figure 7</i>
IA_3–	19		
OB_3+	21	O	Inverting and non-inverting differential outputs of port_3. OB_3+ and OB_3– are connected to V _{CC} through a 50Ω resistor.
OB_3–	22		

Pin Name	Pin Number	I/O	Description
CONTROL (3.3V LVCMOS)			
\overline{EQA}	60	I	This pin is active LOW. A logic LOW at \overline{EQA} enables equalization for input channels IA_0±, IA_1±, IA_2±, and IA_3±. By default, this pin is internally pulled high and equalization is disabled.
\overline{EQB}	16	I	This pin is active LOW. A logic LOW at \overline{EQB} enables equalization for input channels IB_0±, IB_1±, IB_2±, and IB_3±. By default, this pin is internally pulled high and equalization is disabled.
PreA_0 PreA_1	15 1	I	PreA_0 and PreA_1 select the output de-emphasis levels (OA_0±, OA_1±, OA_2±, and OA_3±). PreA_0 and PreA_1 are internally pulled high. Please see <i>Table 2</i> for de-emphasis levels.
PreB_0 PreB_1	31 45	I	PreB_0 and PreB_1 select the output de-emphasis levels (OB_0±, OB_1±, OB_2±, and OB_3±). PreB_0 and PreB_1 are internally pulled high. Please see <i>Table 2</i> for de-emphasis levels.
$\overline{LB0}$	46	I	This pin is active LOW. A logic LOW at $\overline{LB0}$ enables the internal loopback path from IB_0± to OA_0±. $\overline{LB0}$ is internally pulled high. Please see <i>Table 1</i> for more information.
$\overline{LB1}$	44	I	This pin is active LOW. A logic LOW at $\overline{LB1}$ enables the internal loopback path from IB_1± to OA_1±. $\overline{LB1}$ is internally pulled high. Please see <i>Table 1</i> for more information.
$\overline{LB2}$	32	I	This pin is active LOW. A logic LOW at $\overline{LB2}$ enables the internal loopback path from IB_2± to OA_2±. $\overline{LB2}$ is internally pulled high. Please see <i>Table 1</i> for more information.
$\overline{LB3}$	30	I	This pin is active LOW. A logic LOW at $\overline{LB3}$ enables the internal loopback path from IB_3± to OA_3±. $\overline{LB3}$ is internally pulled high. Please see <i>Table 1</i> for more information.
RSV	59	I	Reserve pin to support factory testing. This pin can be left open, tied to GND, or tied to GND through an external pull-down resistor.
POWER			
V _{CC}	5, 11, 20, 26, 35, 41, 50, 56	P	V _{CC} = 3.3V ± 5%. Each V _{CC} pin should be connected to the V _{CC} plane through a low inductance path, typically with a via located as close as possible to the landing pad of the V _{CC} pin. It is recommended to have a 0.01 μF or 0.1 μF, X7R, size-0402 bypass capacitor from each V _{CC} pin to ground plane.
GND	2, 8, 14, 17, 23, 29, 38, 47, 53	P	Ground reference. Each ground pin should be connected to the ground plane through a low inductance path, typically with a via located as close as possible to the landing pad of the GND pin.
GND	DAP	P	DAP is the metal contact at the bottom side, located at the center of the eLLP-60 pin package. It should be connected to the GND plane with at least 4 via to lower the ground impedance and improve the thermal performance of the package.

Note: I = Input, O = Output, P = Power

Functional Description

TABLE 1. Logic Table for Loopback Controls

LB0	Loopback Function
0	Enable loopback from IB_0± to OA_0±.
1 (default)	Normal mode. Loopback disabled.
LB1	Loopback Function
0	Enable loopback from IB_1± to OA_1±.
1 (default)	Normal mode. Loopback disabled.
LB2	Loopback Function
0	Enable loopback from IB_2± to OA_2±.
1 (default)	Normal mode. Loopback disabled.
LB3	Loopback Function
0	Enable loopback from IB_3± to OA_3±.
1 (default)	Normal mode. Loopback disabled.

TABLE 2. De-Emphasis Controls

PreA_[1:0]	Default VOD Level in mV _{pp} (VODB)	De-Emphasis Level in mV _{pp} (VODPE)	De-Emphasis in dB (VODPE/ VODB)
0 0	1200	1200	0
0 1	1200	850	-3
1 0	1200	600	-6
1 1 (Default)	1200	426	-9
PreB_[1:0]	Default VOD Level in mV _{pp} (VODB)	De-Emphasis Level in mV _{pp} (VODPE)	De-Emphasis in dB (VODPE/ VODB)
0 0	1200	1200	0
0 1	1200	850	-3
1 0	1200	600	-6
1 1 (Default)	1200	426	-9

De-emphasis is the conditioning function for use in compensating against backplane transmission loss. The DS25BR400 provides four steps of de-emphasis ranging from 0, -3, -6 and -9 dB, user-selectable dependent on the loss profile of the backplane. *Figure 1* shows a driver de-emphasis wave-

form. The de-emphasis duration is nominal 200 ps, corresponding to 50% bit-width at 2.5 Gbps. The de-emphasis levels of switch-side and line-side can be individually programmed.

Input Equalization

Each differential input of the DS25BR400 has a fixed equalizer front-end stage. Input group A and B can be individually enabled and disabled. It is designed to provide fixed equalization for short board traces with transmission losses of approximately 5 dB between 375 MHz to 1.875 GHz. Programmable de-emphasis together with input equalization en-

ures an acceptable eye opening for a 40-inch FR-4 backplane.

The differential input equalizer for inputs on Channel A and inputs on Channel B can be bypassed by using \overline{EQA} and \overline{EQB} , respectively. By default, the equalizers are internally pulled high and disabled. Therefore, \overline{EQA} and \overline{EQB} must be asserted LOW to enable equalization.

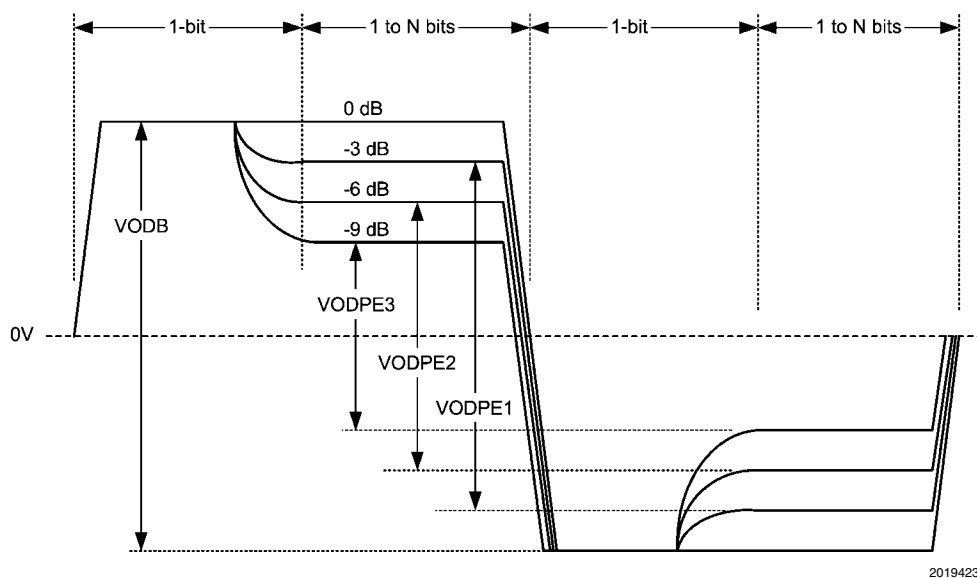

FIGURE 1. Driver De-Emphasis Differential Waveform (showing all 4 de-emphasis steps)

Absolute Maximum Ratings (Note 1)

If Military/Aerospace specified devices are required, please contact the National Semiconductor Sales Office/Distributors for availability and specifications.

Supply Voltage (V_{CC})	-0.3V to 4V
CMOS/TTL Input Voltage	-0.3V to ($V_{CC} + 0.3V$)
CML Input/Output Voltage	-0.3V to ($V_{CC} + 0.3V$)
Junction Temperature	+150°C
Storage Temperature	-65°C to +150°C
Lead Temperature Soldering, 4 sec	+260°C
Thermal Resistance, θ_{JA}	22.3°C/W
Thermal Resistance, θ_{JC}	3.2°C/W
Thermal Resistance, Φ_{JB}	10.3°C/W

ESD Ratings (Note 9)

HBM	6kV
CDM	1kV
MM	350V

Recommended Operating Ratings

	Min	Typ	Max	Units
Supply Voltage (V_{CC-GND})	3.135	3.3	3.465	V
Supply Noise Amplitude 10 Hz to 2 GHz			100	mV _{PP}
Ambient Temperature	-40		+85	°C
Case Temperature			100	°C

Electrical Characteristics

Over recommended operating supply and temperature ranges unless otherwise specified.

Symbol	Parameter	Conditions	Min	Typ (Note 2)	Max	Units
LVC MOS DC SPECIFICATIONS						
V_{IH}	High Level Input Voltage		2.0		$V_{CC} + 0.3$	V
V_{IL}	Low Level Input Voltage		-0.3		0.8	V
I_{IH}	High Level Input Current	$V_{IN} = V_{CC}$	-10		10	μA
I_{IL}	Low Level Input Current	$V_{IN} = GND$	75	94	124	μA
R_{PU}	Pull-High Resistance			35		kΩ
RECEIVER SPECIFICATIONS						
V_{ID}	Differential Input Voltage Range	AC Coupled Differential Signal. Below 1.25 Gb/s At 1.25 Gbps–3.125 Gbps Above 3.125 Gbps This parameter is not production tested.	100 100 100		1750 1560 1200	mV _{P-P} mV _{P-P} mV _{P-P}
V_{ICM}	Common Mode Voltage at Receiver Inputs	Measured at receiver inputs reference to ground.		1.3		V
R_{ITD}	Input Differential Termination	On-chip differential termination between IN+ or IN-. <i>Figure 7</i>	84	100	116	Ω

Symbol	Parameter	Conditions	Min	Typ (Note 2)	Max	Units
DRIVER SPECIFICATIONS						
V _O DB	Output Differential Voltage Swing without De-Emphasis	R _L = 100Ω ±1% PreA_1 = 0; PreA_0 = 0 PreB_1 = 0; PreB_0 = 0 Driver de-emphasis disabled. Running K28.7 pattern at 2.5 Gbps. (Figure 6)	1000	1200	1400	mV _{P-P}
V _{PE}	Output De-Emphasis Voltage Ratio 20*log(VODPE/VODB)	R _L = 100Ω ±1% Running K28.7 pattern at 2.5 Gbps PreX_[1:0] = 00 PreX_[1:0] = 01 PreX_[1:0] = 10 PreX_[1:0] = 11 X = A/B channel de-emphasis drivers (Figure 1 / Figure 6)		0 -3 -6 -9		dB dB dB dB
t _{PE}	De-Emphasis Width	Tested at -9 dB de-emphasis level, PreX[1:0] = 11 X = A/B channel de-emphasis drivers See Figure 5 on measurement condition.	125	200	250	ps
R _{OTSE}	Output Termination	On-chip termination from OUT+ or OUT- to V _{CC}	42	50	58	Ω
R _{OTD}	Output Differential Termination	On-chip differential termination between OUT+ and OUT-		100		Ω
ΔR _{OTSE}	Mis-Match in Output Termination Resistors	Mis-match in output termination resistors			5	%
V _{OCM}	Output Common Mode Voltage			2.7		V
POWER DISSIPATION						
P _D	Power Dissipation	V _{DD} = 3.465V All outputs terminated by 100Ω ±1%. PreB_[1:0] = 0, PreA_[1:0] = 0 Running PRBS 27-1 pattern at 2.5 Gbps			1.3	W
AC CHARACTERISTICS						
t _R	Differential Low to High Transition Time	Measured with a clock-like pattern at 2.5 Gbps, between 20% and 80% of the differential output voltage.		80		ps
t _F	Differential High to Low Transition Time	De-emphasis disabled. Transition time is measured with the fixture shown in Figure 6 adjusted to reflect the transition time at the output pins.		80		ps
t _{PLH}	Differential Low to High Propagation Delay	Measured at 50% differential voltage from input to output.			1	ns
t _{PHL}	Differential High to Low Propagation Delay				1	ns
t _{SKP}	Pulse Skew	t _{PHL} - t _{PLH}			20	ps
t _{SKO}	Output Skew (Note 7)	Difference in propagation delay between channels on the same part (Channel-to-Channel Skew)			100	ps
t _{SKPP}	Part-to-Part Skew (Note 7)	Difference in propagation delay between devices across all channels operating under identical conditions			165	ps
t _{LB}	Loopback Delay Time	Delay from enabling loopback mode to signals appearing at the differential outputs Figure 4			4	ns

Symbol	Parameter	Conditions	Min	Typ (Note 2)	Max	Units
RJ	Device Random Jitter (Note 5)	At 0.25 Gbps At 1.5 Gbps At 2.5 Gbps Alternating-10 pattern. De-emphasis disabled. (Figure 6)			2 2 2	ps rms ps rms ps rms
DJ	Device Deterministic Jitter (Note 6)	At 0.25 Mbps, PRBS7 pattern At 1.5 Gbps, K28.5 pattern At 2.5 Gbps, K28.5 pattern At 2.5 Gbps, PRBS7 pattern De-emphasis disabled. (Figure 6)			25 25 25 25	ps pp ps pp ps pp ps pp
DR	Data Rate (Note 8)	Alternating-10 pattern	0.25		2.5	Gbps

Note 1: "Absolute Maximum Ratings" indicate limits beyond which damage to the device may occur. Operating Ratings indicate conditions for which the device is functional. For guaranteed specifications and the test conditions, see the Electrical Characteristics Tables. Operation of the device beyond the maximum Operating Ratings is not recommended.

Note 2: Typical specifications are at $T_A = 25^\circ\text{C}$, and represent most likely parametric norms at the time of product characterization. The typical specifications are not guaranteed.

Note 3: IN+ and IN- are generic names that refer to one of the many pairs of complementary inputs of the DS25BR400. OUT+ and OUT- are generic names that refer to one of the many pairs of the complementary outputs of the DS25BR400. Differential input voltage V_{ID} is defined as $IIN+ - IN-$. Differential output voltage V_{OD} is defined as $IOUT+ - OUT-$.

Note 4: K28.7 pattern is a 10-bit repeating pattern of K28.7 code group {001111 1000}

K28.5 pattern is a 20-bit repeating pattern of +K28.5 and -K28.5 code groups {110000 0101 001111 1010}

Note 5: Device output random jitter is a measurement of random jitter contributed by the device. It is derived by the equation $\text{SQRT}[(R_{J_{OUT}})^2 - (R_{J_{IN}})^2]$, where $R_{J_{OUT}}$ is the total random jitter measured at the output of the device in ps(rms), $R_{J_{IN}}$ is the random jitter of the pattern generator driving the device. Below 400 Mbps, system jitter and device jitter could not be separated. The 250 Mbps specification includes system random jitter. Please see Figure 6 for the AC test circuit.

Note 6: Device output deterministic jitter is a measurement of the deterministic jitter contribution from the device. It is derived by the equation $(DJ_{OUT} - DJ_{IN})$, where DJ_{OUT} is the total peak-to-peak deterministic jitter measured at the output of the device in ps(p-p). DJ_{IN} is the peak-to-peak deterministic jitter at the input of the test board. Please see Figure 6 for the AC test circuit.

Note 7: t_{SKO} is the magnitude difference in propagation delays between all data paths on one device. This is channel-to-channel skew. t_{SKPP} is the worst case difference in propagation delay across multiple devices on all channels and operating under identical conditions. For example, for two devices operating under the same conditions, t_{SKPP} is the magnitude difference between the shortest propagation delay measurement on one device to the longest propagation delay measurement on another device.

Note 8: This parameter is guaranteed by design and/or characterization and is not tested in production.

Note 9: ESD tests conform to the following standards:

Human Body Model (HBM) applicable standard: MIL-STD-883, Method 3015.7

Machine Model (MM) applicable standard: JESD22-A115-A (ESD MM std. of JEDEC)

Field -Induced Charge Device Model (CDM) applicable standard: JESD22-C101-C (ESD FICDM std. of JEDEC)

Timing Diagrams

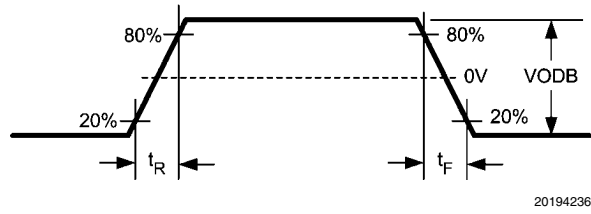

FIGURE 2. Driver Output Transition Time

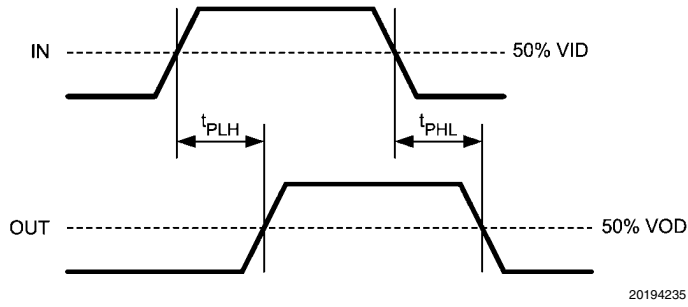

FIGURE 3. Propagation Delay

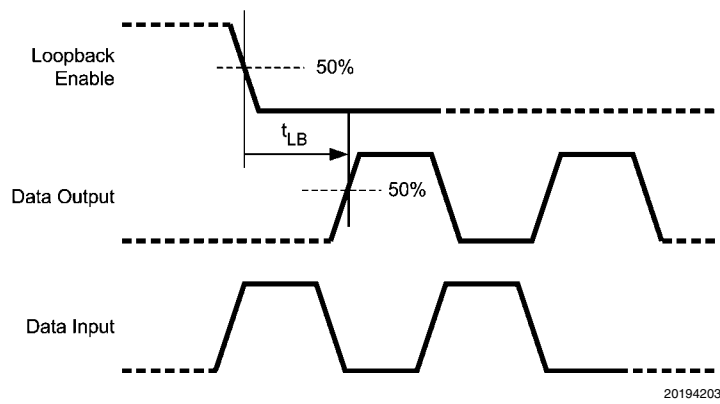
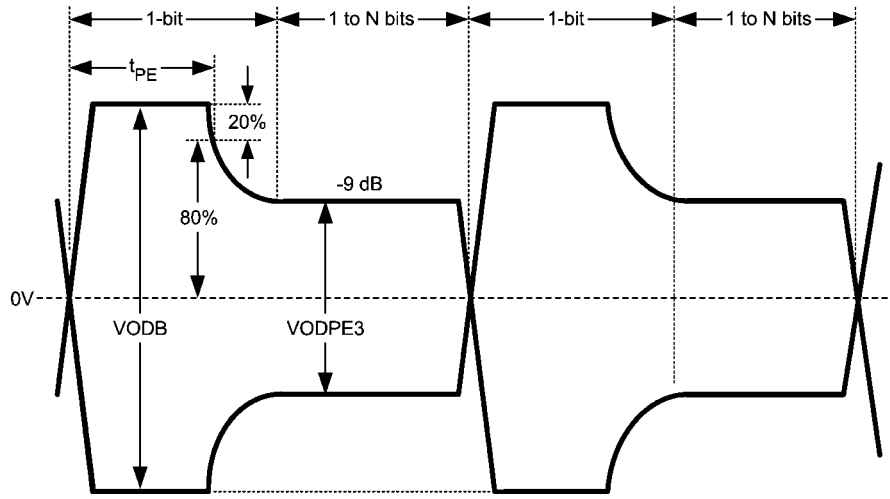
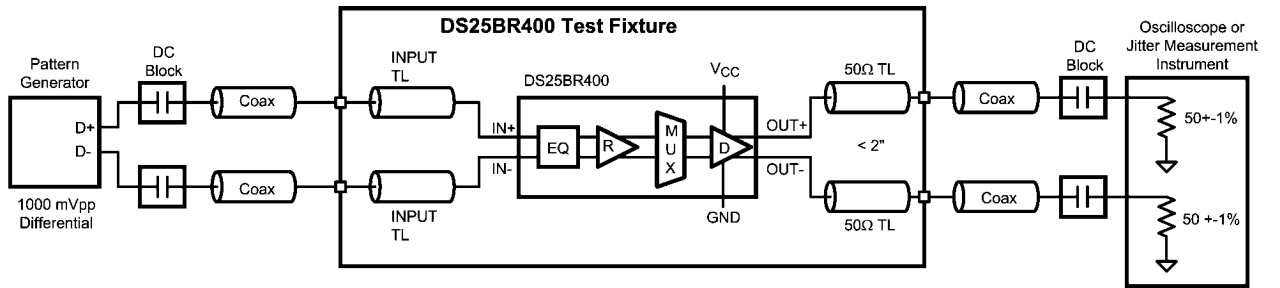

FIGURE 4. Loopback Delay Timing



20194239

FIGURE 5. Output De-Emphasis Duration



20194234

FIGURE 6. AC Test Circuit

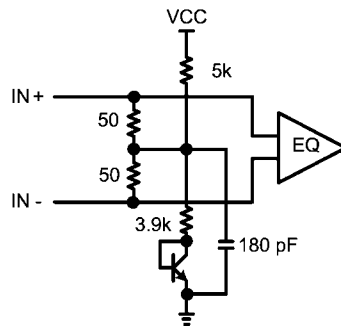

20194241

FIGURE 7. Receiver Input Termination

Physical Dimensions inches (millimeters) unless otherwise noted

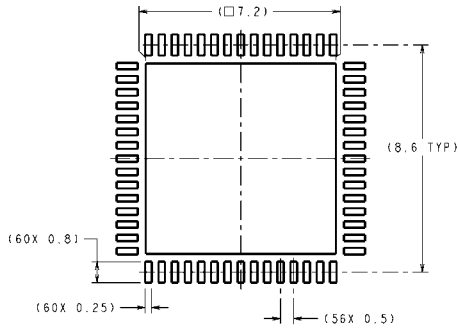

RECOMMENDED LAND PATTERN

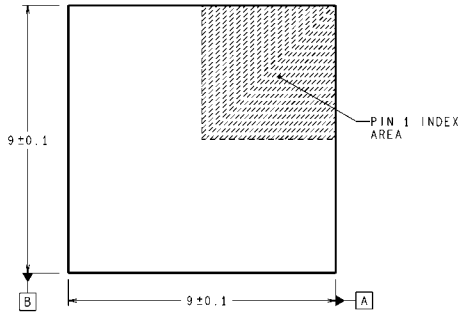

DIMENSIONS ARE IN MILLIMETERS
DIMENSION IN () FOR REFERENCE ONLY

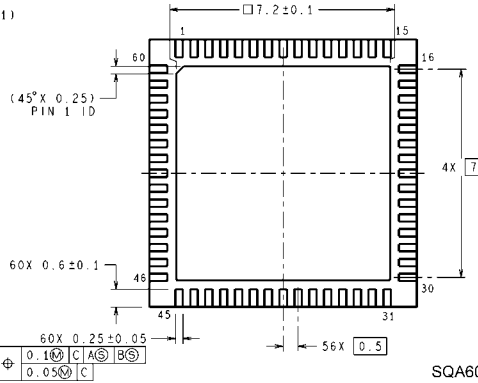
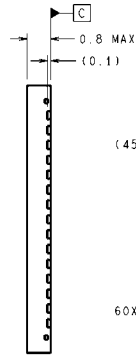
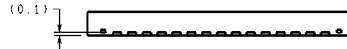

SQA60A (Rev A)

eLLP-60 Package
Order Number DS25BR400TSQ
NS Package Number SQA060

Notes

For more National Semiconductor product information and proven design tools, visit the following Web sites at:

Products		Design Support	
Amplifiers	www.national.com/amplifiers	WEBENCH	www.national.com/webench
Audio	www.national.com/audio	Analog University	www.national.com/AU
Clock Conditioners	www.national.com/timing	App Notes	www.national.com/appnotes
Data Converters	www.national.com/adc	Distributors	www.national.com/contacts
Displays	www.national.com/displays	Green Compliance	www.national.com/quality/green
Ethernet	www.national.com/ethernet	Packaging	www.national.com/packaging
Interface	www.national.com/interface	Quality and Reliability	www.national.com/quality
LVDS	www.national.com/lvds	Reference Designs	www.national.com/refdesigns
Power Management	www.national.com/power	Feedback	www.national.com/feedback
Switching Regulators	www.national.com/switchers		
LDOs	www.national.com/lido		
LED Lighting	www.national.com/led		
PowerWise	www.national.com/powerwise		
Serial Digital Interface (SDI)	www.national.com/sdi		
Temperature Sensors	www.national.com/tempsensors		
Wireless (PLL/VCO)	www.national.com/wireless		

THE CONTENTS OF THIS DOCUMENT ARE PROVIDED IN CONNECTION WITH NATIONAL SEMICONDUCTOR CORPORATION ("NATIONAL") PRODUCTS. NATIONAL MAKES NO REPRESENTATIONS OR WARRANTIES WITH RESPECT TO THE ACCURACY OR COMPLETENESS OF THE CONTENTS OF THIS PUBLICATION AND RESERVES THE RIGHT TO MAKE CHANGES TO SPECIFICATIONS AND PRODUCT DESCRIPTIONS AT ANY TIME WITHOUT NOTICE. NO LICENSE, WHETHER EXPRESS, IMPLIED, ARISING BY ESTOPPEL OR OTHERWISE, TO ANY INTELLECTUAL PROPERTY RIGHTS IS GRANTED BY THIS DOCUMENT.

TESTING AND OTHER QUALITY CONTROLS ARE USED TO THE EXTENT NATIONAL DEEMS NECESSARY TO SUPPORT NATIONAL'S PRODUCT WARRANTY. EXCEPT WHERE MANDATED BY GOVERNMENT REQUIREMENTS, TESTING OF ALL PARAMETERS OF EACH PRODUCT IS NOT NECESSARILY PERFORMED. NATIONAL ASSUMES NO LIABILITY FOR APPLICATIONS ASSISTANCE OR BUYER PRODUCT DESIGN. BUYERS ARE RESPONSIBLE FOR THEIR PRODUCTS AND APPLICATIONS USING NATIONAL COMPONENTS. PRIOR TO USING OR DISTRIBUTING ANY PRODUCTS THAT INCLUDE NATIONAL COMPONENTS, BUYERS SHOULD PROVIDE ADEQUATE DESIGN, TESTING AND OPERATING SAFEGUARDS.

EXCEPT AS PROVIDED IN NATIONAL'S TERMS AND CONDITIONS OF SALE FOR SUCH PRODUCTS, NATIONAL ASSUMES NO LIABILITY WHATSOEVER, AND NATIONAL DISCLAIMS ANY EXPRESS OR IMPLIED WARRANTY RELATING TO THE SALE AND/OR USE OF NATIONAL PRODUCTS INCLUDING LIABILITY OR WARRANTIES RELATING TO FITNESS FOR A PARTICULAR PURPOSE, MERCHANTABILITY, OR INFRINGEMENT OF ANY PATENT, COPYRIGHT OR OTHER INTELLECTUAL PROPERTY RIGHT.

LIFE SUPPORT POLICY

NATIONAL'S PRODUCTS ARE NOT AUTHORIZED FOR USE AS CRITICAL COMPONENTS IN LIFE SUPPORT DEVICES OR SYSTEMS WITHOUT THE EXPRESS PRIOR WRITTEN APPROVAL OF THE CHIEF EXECUTIVE OFFICER AND GENERAL COUNSEL OF NATIONAL SEMICONDUCTOR CORPORATION. As used herein:

Life support devices or systems are devices which (a) are intended for surgical implant into the body, or (b) support or sustain life and whose failure to perform when properly used in accordance with instructions for use provided in the labeling can be reasonably expected to result in a significant injury to the user. A critical component is any component in a life support device or system whose failure to perform can be reasonably expected to cause the failure of the life support device or system or to affect its safety or effectiveness.

National Semiconductor and the National Semiconductor logo are registered trademarks of National Semiconductor Corporation. All other brand or product names may be trademarks or registered trademarks of their respective holders.

Copyright© 2008 National Semiconductor Corporation

For the most current product information visit us at www.national.com



**National Semiconductor
Americas Technical
Support Center**
Email:
new.feedback@nsc.com
Tel: 1-800-272-9959

**National Semiconductor Europe
Technical Support Center**
Email: europe.support@nsc.com
German Tel: +49 (0) 180 5010 771
English Tel: +44 (0) 870 850 4288

**National Semiconductor Asia
Pacific Technical Support Center**
Email: ap.support@nsc.com

**National Semiconductor Japan
Technical Support Center**
Email: jpn.feedback@nsc.com