

DS40MB200

Dual 4.0 Gbps 2:1/1:2 CML Mux/Buffer with Transmit Pre-Emphasis and Receive Equalization

General Description

The DS40MB200 is a dual signal conditioning 2:1 multiplexer and 1:2 fan-out buffer designed for use in backplane redundancy applications. Signal conditioning features include input equalization and programmable output pre-emphasis that enable data communication in FR4 backplanes up to 4 Gbps. Each input stage has a fixed equalizer to reduce ISI distortion from board traces.

All output drivers have 4 selectable steps of pre-emphasis to compensate for transmission losses from long FR4 backplanes and reduce deterministic jitter. The pre-emphasis levels can be independently controlled for the line-side and switch-side drivers. The internal loopback paths from switch-side input to switch-side output enable at-speed system testing. All receiver inputs are internally terminated with 100Ω differential terminating resistors. All drivers are internally terminated with 50Ω to V_{CC}.

Features

- 1– 4 Gbps low jitter operation
- Fixed input equalization
- Programmable output pre-emphasis
- Independent switch and line side pre-emphasis controls
- Programmable switch-side loopback mode
- On-chip terminations
- +3.3V supply
- ESD rating HBM 6 kV
- Lead-less LLP-48 package (7 mm x 7 mm)
- 0°C to +85°C operating temperature range

Applications

- Backplane or cable driver
- Redundancy and signal conditioning applications
- XAUI

Functional Block Diagram

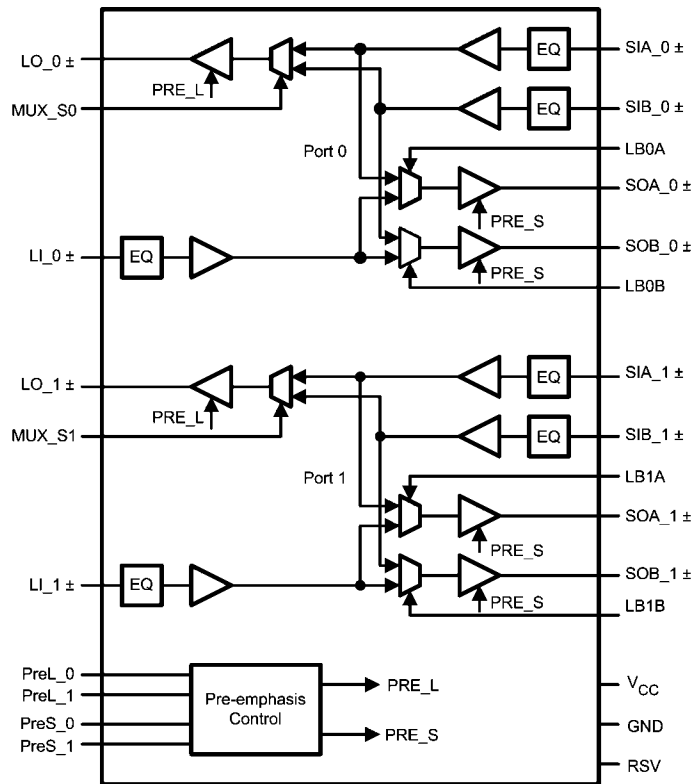

Simplified Block Diagram

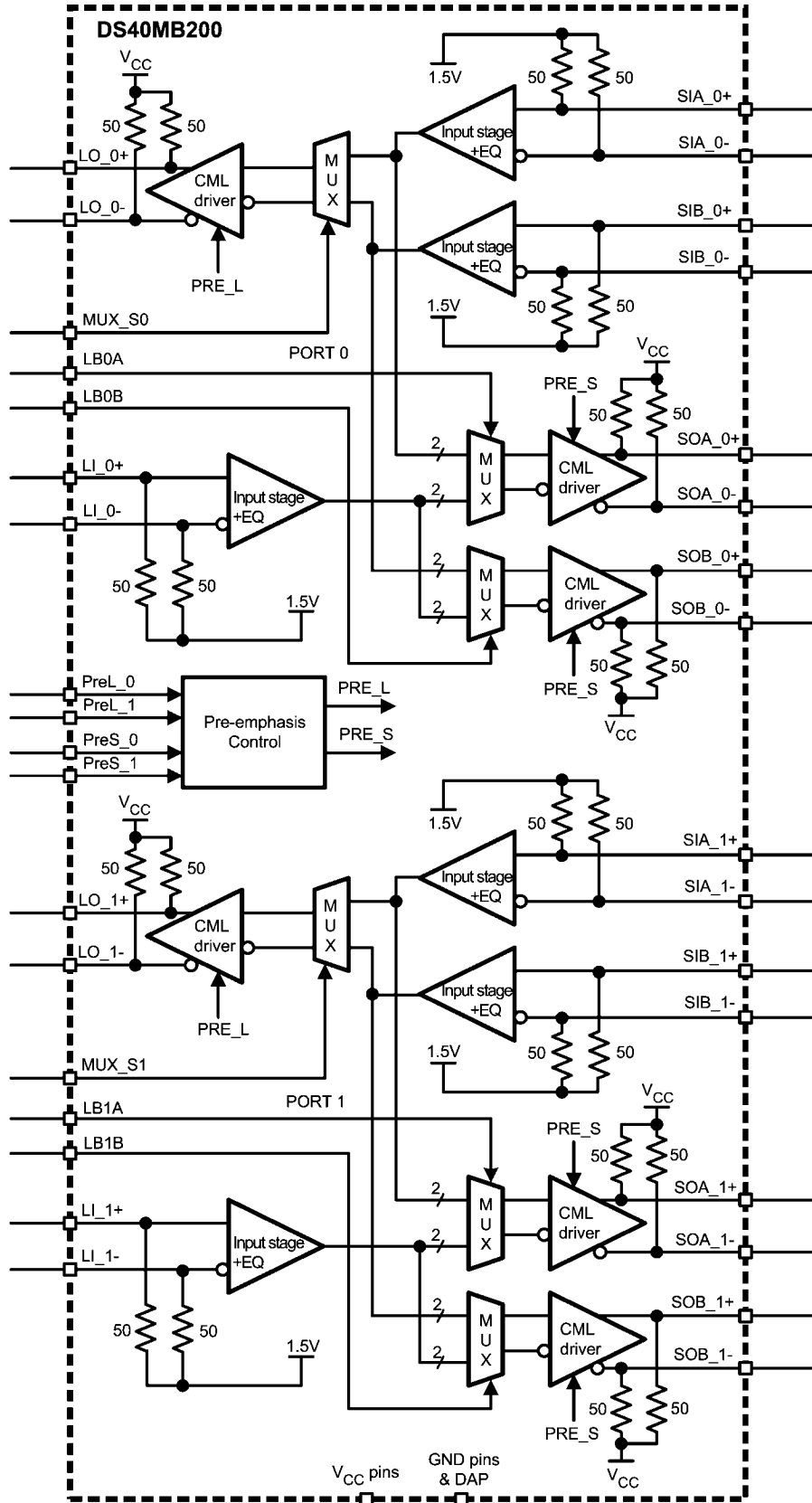

20021731

Connection Diagram

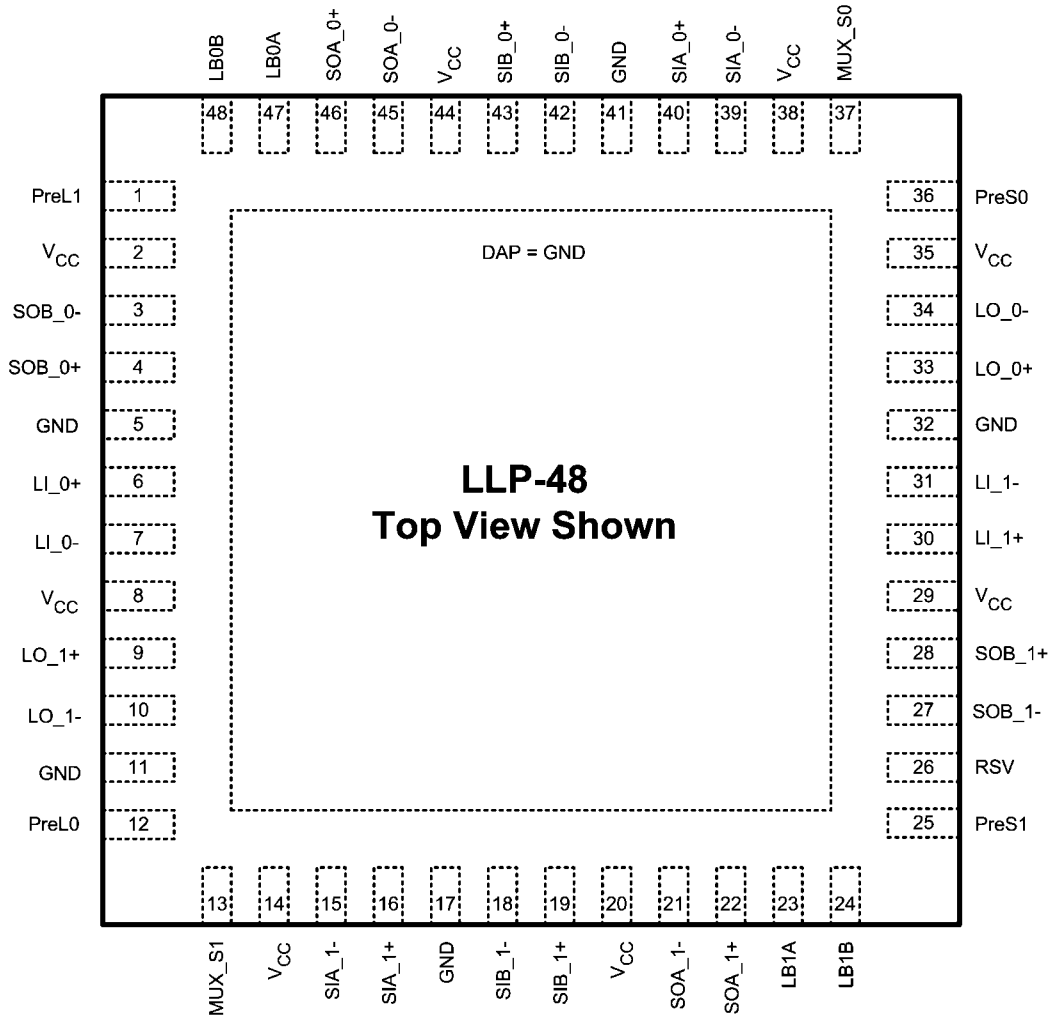

Order number DS40MB200SQ
See NS Package Number SQA48D

20021732

Pin Descriptions

Pin Name	Pin Number	I/O	Description
LINE SIDE HIGH SPEED DIFFERENTIAL IO's			
LI_0+	6	I	Inverting and non-inverting differential inputs of port_0 at the line side. LI_0+ and LI_0- have an internal 50Ω connected to an internal reference voltage. See <i>Figure 6</i> .
LI_0-	7		
LO_0+	33	O	Inverting and non-inverting differential outputs of port_0 at the line side. LO_0+ and LO_0- have an internal 50Ω connected to V _{CC} .
LO_0-	34		
LI_1+	30	I	Inverting and non-inverting differential inputs of port_1 at the line side. LI_1+ and LI_1- have an internal 50Ω connected to an internal reference voltage. See <i>Figure 6</i>
LI_1-	31		
LO_1+	9	O	Inverting and non-inverting differential outputs of port_1 at the line side. LO_1+ and LO_1- have an internal 50Ω connected to V _{CC} .
LO_1-	10		
SWITCH SIDE HIGH SPEED DIFFERENTIAL IO's			
SOA_0+	46	O	Inverting and non-inverting differential outputs of mux_0 at the switch_A side. SOA_0+ and SOA_0- have an internal 50Ω connected to V _{CC} .
SOA_0-	45		
SOB_0+	4	O	Inverting and non-inverting differential outputs of mux_0 at the switch_B side. SOB_0+ and SOB_0- have an internal 50Ω connected to V _{CC} .
SOB_0-	3		
SIA_0+	40	I	Inverting and non-inverting differential inputs to the mux_0 at the switch_A side. SIA_0+ and SIA_0- have an internal 50Ω connected to an internal reference voltage. See <i>Figure 6</i> .
SIA_0-	39		
SIB_0+	43	I	Inverting and non-inverting differential inputs to the mux_0 at the switch_B side. SIB_0+ and SIB_0- have an internal 50Ω connected to an internal reference voltage. See <i>Figure 6</i> .
SIB_0-	42		
SOA_1+	22	O	Inverting and non-inverting differential outputs of mux_1 at the switch_A side. SOA_1+ and SOA_1- have an internal 50Ω connected to V _{CC} .
SOA_1-	21		
SOB_1+	28	O	Inverting and non-inverting differential outputs of mux_1 at the switch_B side. SOB_1+ and SOB_1- have an internal 50Ω connected to V _{CC} .
SOB_1-	27		
SIA_1+	16	I	Inverting and non-inverting differential inputs to the mux_1 at the switch_A side. SIA_1+ and SIA_1- have an internal 50Ω connected to an internal reference voltage. See <i>Figure 6</i> .
SIA_1-	15		
SIB_1+	19	I	Inverting and non-inverting differential inputs to the mux_1 at the switch_B side. SIB_1+ and SIB_1- have an internal 50Ω connected to an internal reference voltage. See <i>Figure 6</i> .
SIB_1-	18		
CONTROL (3.3V LVCMOS)			
MUX_S0	37	I	A logic low at MUX_S0 selects mux_0 to switch B. MUX_S0 is internally pulled high. Default state for mux_0 is switch A.
MUX_S1	13	I	A logic low at MUX_S1 selects mux_1 to switch B. MUX_S1 is internally pulled high. Default state for mux_1 is switch A.
PREL_0	12	I	PREL_0 and PREL_1 select the output pre-emphasis of the line side drivers (LO_0± and LO_1±). PREL_0 and PREL_1 are internally pulled high. See <i>Table 3</i> for line side pre-emphasis levels.
PREL_1	1		
PRES_0	36	I	PRES_0 and PRES_1 select the output pre-emphasis of the switch side drivers (SOA_0±, SOB_0±, SOA_1± and SOB_1±). PRES_0 and PRES_1 are internally pulled high. See <i>Table 4</i> for switch side pre-emphasis levels.
PRES_1	25		
LB0A	47	I	A logic low at LB0A enables the internal loopback path from SIA_0± to SOA_0±. LB0A is internally pulled high.
LB0B	48	I	A logic low at LB0B enables the internal loopback path from SIB_0± to SOB_0±. LB0B is internally pulled high.
LB1A	23	I	A logic low at LB1A enables the internal loopback path from SIA_1± to SOA_1±. LB1A is internally pulled high.
LB1B	24	I	A logic low at LB1B enables the internal loopback path from SIB_1± to SOB_1±. LB1B is internally pulled high.
RSV	26	I	Reserve pin to support factory testing. This pin can be left open, or tied to GND, or tied to GND through an external pull-down resistor.

Pin Name	Pin Number	I/O	Description
POWER			
V _{CC}	2, 8, 14, 20, 29, 35, 38, 44	P	V _{CC} = 3.3V ± 5%. Each V _{CC} pin should be connected to the V _{CC} plane through a low inductance path, typically with a via located as close as possible to the landing pad of the V _{CC} pin. It is recommended to have a 0.01 μF or 0.1 μF, X7R, size-0402 bypass capacitor from each V _{CC} pin to ground plane.
GND	5, 11, 17, 32, 41	P	Ground reference. Each ground pin should be connected to the ground plane through a low inductance path, typically with a via located as close as possible to the landing pad of the GND pin.
GND	DAP	P	Die Attach Pad (DAP) is the metal contact at the bottom side, located at the center of the LLP-48 package. It should be connected to the GND plane with at least 4 via to lower the ground impedance and improve the thermal performance of the package.

Note: I = Input, O = Output, P = Power

Functional Description

The DS40MB200 is a signal conditioning 2:1 multiplexer and a 1:2 buffer designed to support port redundancy up to 4 Gb/s. Each input stage has a fixed equalizer that provides equalization to compensate about 5 dB of transmission loss from a short backplane trace (about 10 inches backplane). The output driver has pre-emphasis (driver-side equalization) to compensate the transmission loss of the backplane that it is driving. The driver conditions the output signal such that the lower frequency and higher frequency pulses reach approximately the same amplitude at the end of the backplane, and minimize the deterministic jitter caused by the amplitude dis-

parity. The DS40MB200 provides 4 steps of user-selectable pre-emphasis ranging from 0, -3, -6 and -9 dB to handle different lengths of backplane. Figure 1 shows a driver pre-emphasis waveform. The pre-emphasis duration is 200ps nominal, corresponds to 0.8 bit-width at 4 Gb/s. The pre-emphasis levels of switch-side and line-side can be individually programmed.

The high speed inputs are self-biased to about 1.5V and are designed for AC coupling. The inputs are compatible to most AC coupling differential signals such as LVDS, LVPECL and CML. See *Figure 6* for details.

TABLE 1. LOGIC TABLE FOR MULTIPLEX CONTROLS

MUX_S0	Mux Function
0	MUX_0 select switch_B input, SIB_0±.
1 (default)	MUX_0 select switch_A input, SIA_0±.
MUX_S1	Mux Function
0	MUX_1 select switch_B input, SIB_1±.
1 (default)	MUX_1 select switch_A input, SIA_0±.

TABLE 2. LOGIC TABLE FOR LOOPBACK Controls

LB0A	Loopback Function
0	Enable loopback from SIA_0± to SOA_0±.
1 (default)	Normal mode. Loopback disabled.
LB0B	Loopback Function
0	Enable loopback from SIB_0± to SOB_0±.
1 (default)	Normal mode. Loopback disabled.
LB1A	Loopback Function
0	Enable loopback from SIA_1± to SOA_1±.
1 (default)	Normal mode. Loopback disabled.
LB1B	Loopback Function
0	Enable loopback from SIB_1± to SOB_1±.
1 (default)	Normal mode. Loopback disabled.

TABLE 3. LINE-SIDE PRE-EMPHASIS CONTROLS

PreL_[1:0]	Pre-Emphasis Level in mV_{PP} (VODB)	De-Emphasis Level in mV_{PP} (VODPE)	Pre-Emphasis in dB (VODPE/VODB)	Typical FR4 board trace
0 0	1200	1200	0	10 inches
0 1	1200	850	-3	20 inches
1 0	1200	600	-6	30 inches
1 1 (default)	1200	426	-9	40 inches

TABLE 4. SWITCH-SIDE PRE-EMPHASIS CONTROLS

PreS_[1:0]	Pre-Emphasis Level in mV_{PP} (VODB)	De-Emphasis Level in mV_{PP} (VODPE)	Pre-Emphasis in dB (VODPE/VODB)	Typical FR4 board trace
0 0	1200	1200	0	10 inches
0 1	1200	850	-3	20 inches
1 0	1200	600	-6	30 inches
1 1 (default)	1200	426	-9	40 inches

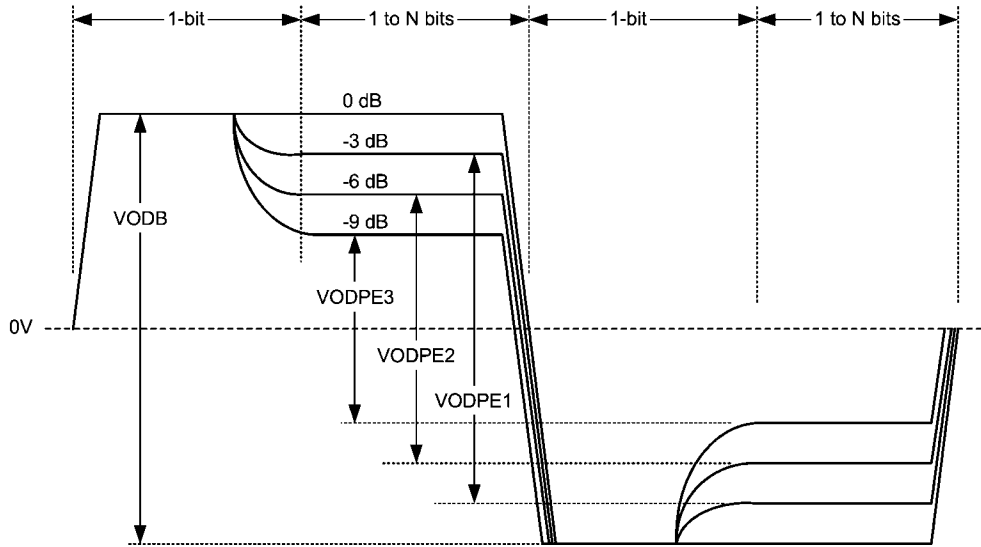

FIGURE 1. Driver Pre-Emphasis Differential Waveform (showing all 4 pre-emphasis steps)

Absolute Maximum Ratings (Note 1)

If Military/Aerospace specified devices are required, please contact the National Semiconductor Sales Office/Distributors for availability and specifications.

Supply Voltage (V_{CC})	-0.3V to 4V
CMOS/TTL Input Voltage	-0.3V to ($V_{CC}+0.3V$)
CML Input/Output Voltage	-0.3V to ($V_{CC}+0.3V$)
Junction Temperature	+125°C
Storage Temperature	-65°C to +150°C
Lead Temperature Soldering, 4 sec	+260°C
Thermal Resistance, θ_{JA}	33.7°C/W
Thermal Resistance, θ_{JC-top}	20.7°C/W
Thermal Resistance, $\theta_{JC-bottom}$	5.8°C/W

Thermal Resistance, Φ_{JB}	18.2°C/W
ESD Rating HBM, 1.5 k Ω , 100 pF	6 kV
ESD Rating Machine Model	250V

Recommended Operating Ratings

	Min	Typ	Max	Units
Supply Voltage ($V_{CC}-GND$)	3.135	3.3	3.465	V
Supply Noise Amplitude 10 Hz to 2 GHz			20	mV _{PP}
Ambient Temperature	0		85	°C
Case Temperature			100	°C

Electrical Characteristics

Over recommended operating supply and temperature ranges unless otherwise specified.

Symbol	Parameter	Conditions	Min	Typ (Note 2)	Max	Units
LVC MOS DC SPECIFICATIONS						
V_{IH}	High Level Input Voltage		2.0		$V_{CC}+0.3$	V
V_{IL}	Low Level Input Voltage		-0.3		0.8	V
I_{IH}	High Level Input Current	$V_{IN} = V_{CC}$	-10		10	μA
I_{IL}	Low Level Input Current	$V_{IN} = GND$	75	94	124	μA
R_{PU}	Pull-High Resistance			35		k Ω
RECEIVER SPECIFICATIONS						
V_{ID}	Differential Input Voltage Range	AC Coupled Differential Signal Below 1.25 Gbps At 1.25 Gbps–3.125 Gbps Above 3.125 Gbps This parameter is not production tested.	100 100 100		1750 1560 1200	mV _{P-P} mV _{P-P} mV _{P-P}
V_{ICM}	Common Mode Voltage at Receiver Inputs	Measured at receiver inputs reference to ground.		1.3		V
R_{ITD}	Input Differential Termination	On-chip differential termination between IN+ or IN-.	84	100	116	Ω
DRIVER SPECIFICATIONS						
VODB	Output Differential Voltage Swing without Pre-Emphasis	$R_L = 100\Omega \pm 1\%$ PRES_1=PRES_0=0 PREL_1=PREL_0=0 Driver pre-emphasis disabled. Running K28.7 pattern at 4 Gbps. See Figure 5 for test circuit.	1000	1200	1400	mV _{P-P}
V_{PE}	Output Pre-Emphasis Voltage Ratio $20 \cdot \log(VODPE/VODB)$	$R_L = 100\Omega \pm 1\%$ Running K28.7 pattern at 4 Gbps PREx_[1:0]=00 PREx_[1:0]=01 PREx_[1:0]=10 PREx_[1:0]=11 x=S for switch side pre-emphasis control x=L for line side pre-emphasis control See Figure 1 on waveform. See Figure 5 for test circuit.		0 -3 -6 -9		dB dB dB dB

Symbol	Parameter	Conditions	Min	Typ (Note 2)	Max	Units
t_{PE}	Pre-Emphasis Width (Note 8)	Tested at -9 dB pre-emphasis level, PREx[1:0]=11 x=S for switch side pre-emphasis control x=L for line side pre-emphasis control See <i>Figure 4</i> on measurement condition.	125	200	250	ps
R_{OTSE}	Output Termination	On-chip termination from OUT+ or OUT- to V_{CC}	42	50	58	Ω
R_{OTD}	Output Differential Termination	On-chip differential termination between OUT+ and OUT-		100		Ω
ΔR_{OTSE}	Mis-Match in Output Termination Resistors	Mis-match in output terminations at OUT+ and OUT-			5	%
V_{OCM}	Output Common Mode Voltage			2.7		V
POWER DISSIPATION						
P_D	Power Dissipation	$V_{DD} = 3.465V$ All outputs terminated by $100\Omega \pm 1\%$. PREL_[1:0]=0, PRES_[1:0]=0 Running PRBS 27-1 pattern at 4 Gbps			1	W
AC CHARACTERISTICS						
t_R	Differential Low to High Transition Time	Measured with a clock-like pattern at 100 MHz, between 20% and 80% of the differential output voltage. Pre-emphasis disabled. Transition time is measured with fixture as shown in <i>Figure 5</i> , adjusted to reflect the transition time at the output pins.		80		ps
t_F	Differential High to Low Transition Time			80		ps
t_{PLH}	Differential Low to High Propagation Delay	Measured at 50% differential voltage from input to output.		0.5	2	ns
t_{PHL}	Differential High to Low Propagation Delay			0.5	2	ns
t_{SKP}	Pulse Skew (Note 8)	$ t_{PHL} - t_{PLH} $			20	ps
t_{SKO}	Output Skew (Notes 7, 8)	Difference in propagation delay among data paths in the same device.			200	ps
t_{SKPP}	Part-to-Part Skew (Note 8)	Difference in propagation delay between the same output from devices operating under identical condition.			500	ps
t_{SM}	Mux Switch Time	Measured from V_{IH} or V_{IL} of the mux-control or loopback control to 50% of the valid differential output.		1.8	6	ns
RJ	Device Random Jitter (Notes 5, 8)	See <i>Figure 5</i> for test circuit. Alternating-1-0 pattern. Pre-emphasis disabled. At 1.25 Gbps At 4 Gbps			2 2	psrms psrms
DJ	Device Deterministic Jitter (Notes 6, 8)	See <i>Figure 5</i> for test circuit. Pre-emphasis disabled. At 4 Gbps, PRBS7 pattern			30	pspp
DR_{MAX}	Maximum Data Rate (Note 8)	Tested with alternating-1-0 pattern	4			Gbps
<p>Note 1: "Absolute Maximum Ratings" are the ratings beyond which the safety of the device cannot be guaranteed. They are not meant to imply that the device should be operated at these limits.</p> <p>Note 2: Typical parameters measured at $V_{CC} = 3.3V$, $T_A = 25^\circ C$. They are for reference purposes and are not production-tested.</p> <p>Note 3: IN+ and IN- are generic names refer to one of the many pairs of complimentary inputs of the DS40MB200. OUT+ and OUT- are generic names refer to one of the many pairs of the complimentary outputs of the DS40MB200. Differential input voltage V_{ID} is defined as $IN+ - IN-$. Differential output voltage V_{OD} is defined as $OUT+ - OUT-$.</p> <p>Note 4: K28.7 pattern is a 10-bit repeating pattern of K28.7 code group {001111 1000} K28.5 pattern is a 20-bit repeating pattern of +K28.5 and -K28.5 code groups {110000 0101 001111 1010}</p>						

Note 5: Device output random jitter is a measurement of the random jitter contribution from the device. It is derived by the equation $\sqrt{RJ_{OUT}^2 - RJ_{IN}^2}$, where RJ_{OUT} is the random jitter measured at the output of the device in psrms, RJ_{IN} is the random jitter of the pattern generator driving the device.

Note 6: Device output deterministic jitter is a measurement of the deterministic jitter contribution from the device. It is derived by the equation $(DJ_{OUT} - DJ_{IN})$, where DJ_{OUT} is the peak-to-peak deterministic jitter measured at the output of the device in pspp, DJ_{IN} is the peak-to-peak deterministic jitter of the pattern generator driving the device.

Note 7: t_{SKO} is the magnitude difference in the propagation delays among data paths between switch A and switch B of the same port and similar data paths between port 0 and port 1. An example is the output skew among data paths from $SIA_{0\pm}$ to $LO_{0\pm}$, $SIB_{0\pm}$ to $LO_{0\pm}$, $SIA_{1\pm}$ to $LO_{1\pm}$ and $SIB_{1\pm}$ to $LO_{1\pm}$. Another example is the output skew among data paths from $LI_{0\pm}$ to $SOA_{0\pm}$, $LI_{0\pm}$ to $SOB_{0\pm}$, $LI_{1\pm}$ to $SOA_{1\pm}$ and $LI_{1\pm}$ to $SOB_{1\pm}$. t_{SKO} also refers to the delay skew of the loopback paths of the same port and between similar data paths between port 0 and port 1. An example is the output skew among data paths $SIA_{0\pm}$ to $SOA_{0\pm}$, $SIB_{0\pm}$ to $SOB_{0\pm}$, $SIA_{1\pm}$ to $SOA_{1\pm}$ and $SIB_{1\pm}$ to $SOB_{1\pm}$.

Note 8: Guaranteed by design and characterization using statistical analysis.

Timing Diagrams

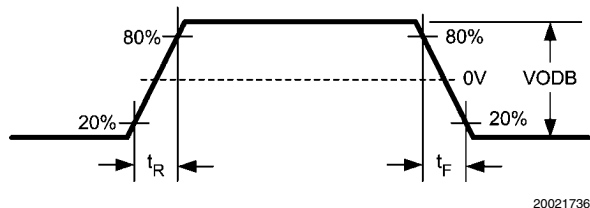

FIGURE 2. Driver Output Transition Time

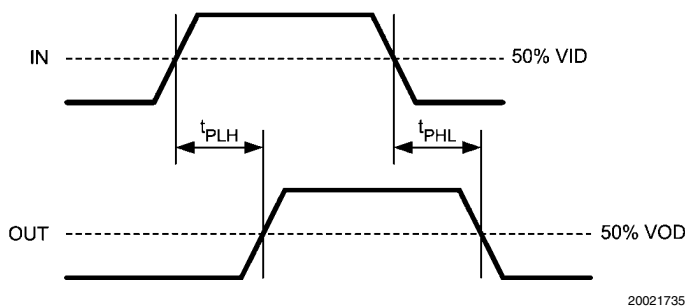

FIGURE 3. Propagation Delay from input to output

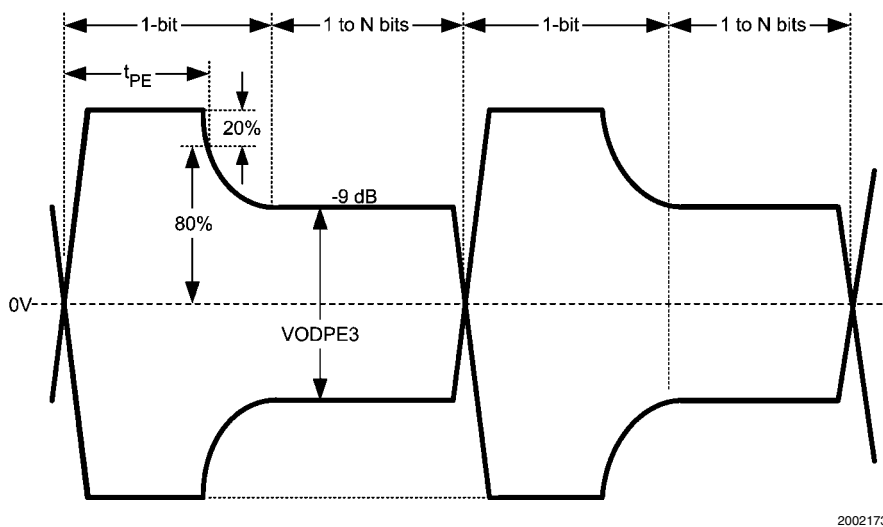
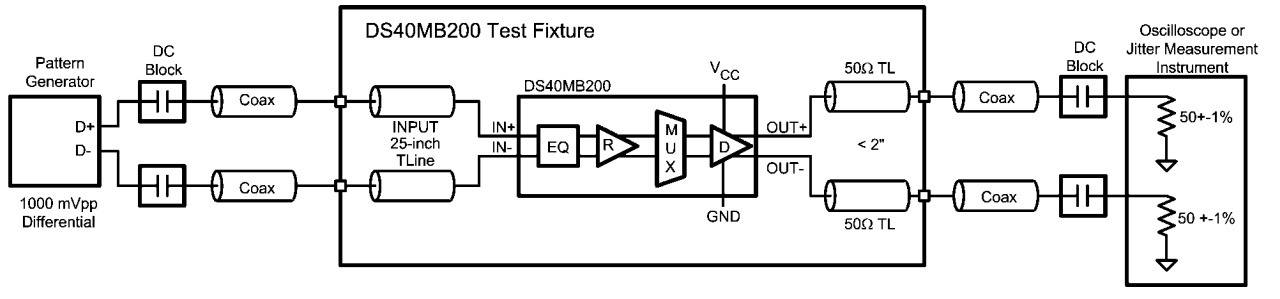
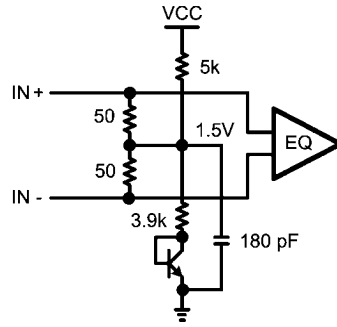

FIGURE 4. Test condition for output pre-emphasis duration



20021734

FIGURE 5. AC Test Circuit



20021750

FIGURE 6. Receiver Input Termination and Bias Circuit

Applications Information

The DS40MB200 input equalizer provides equalization to compensate about 5 dB of transmission loss from a short backplane transmission line. For characterization purposes, a 25-inch FR4 coupled micro-strip board trace is used in place

of the short backplane link. The 25-inch microstrip board trace has approximately 5 dB of attenuation between 375 MHz and 1.875 GHz, representing closely the transmission loss of the short backplane transmission line. The 25-inch microstrip is connected between the pattern generator and the differential inputs of the DS40MB200 for AC measurements.

Trace Length	Finished Trace Width W	Separation between Traces	Dielectric Height H	Dielectric Constant ϵ_R	Loss Tangent
25 inches	8.5 mil	11.5 mil	6 mil	3.8	0.022

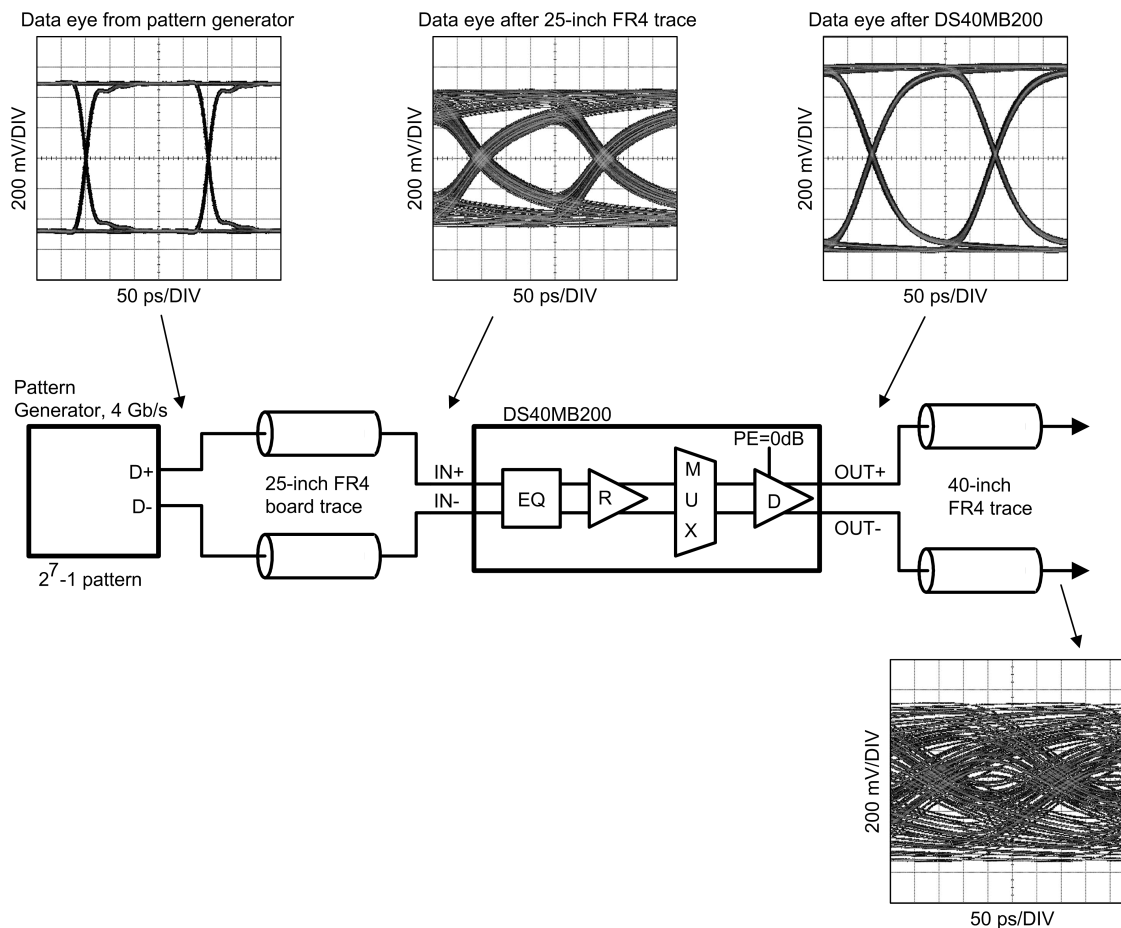

20021742

FIGURE 7. Data input and output eye patterns with driver set to 0 dB pre-emphasis

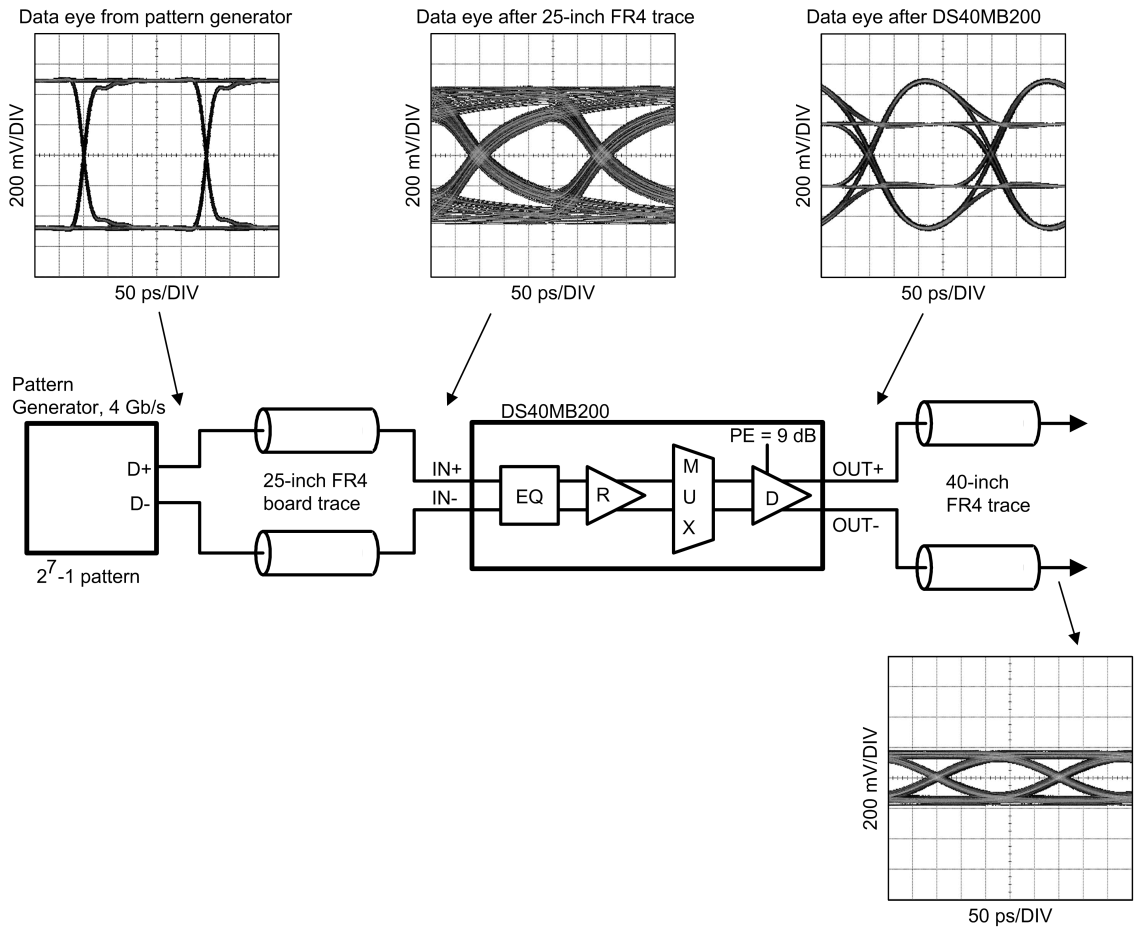

20021743

FIGURE 8. Data input and output eye patterns with driver set to 9 dB pre-emphasis

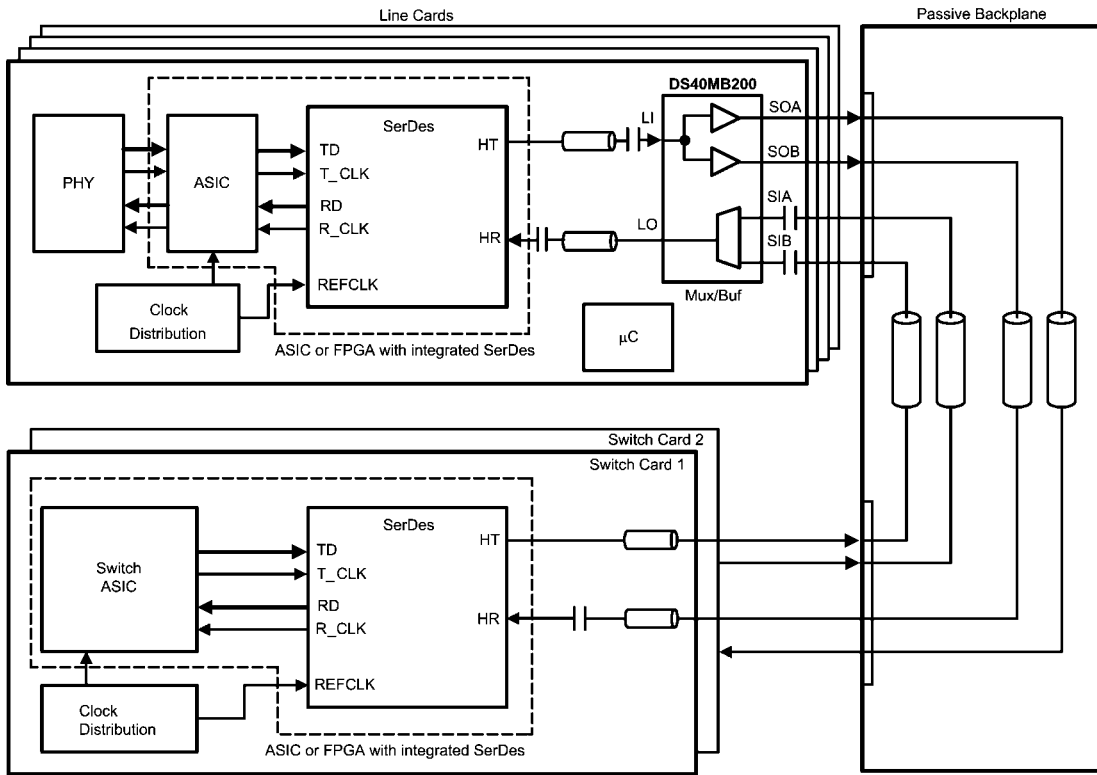

20021744

FIGURE 9. System diagram (showing data paths of port 0)

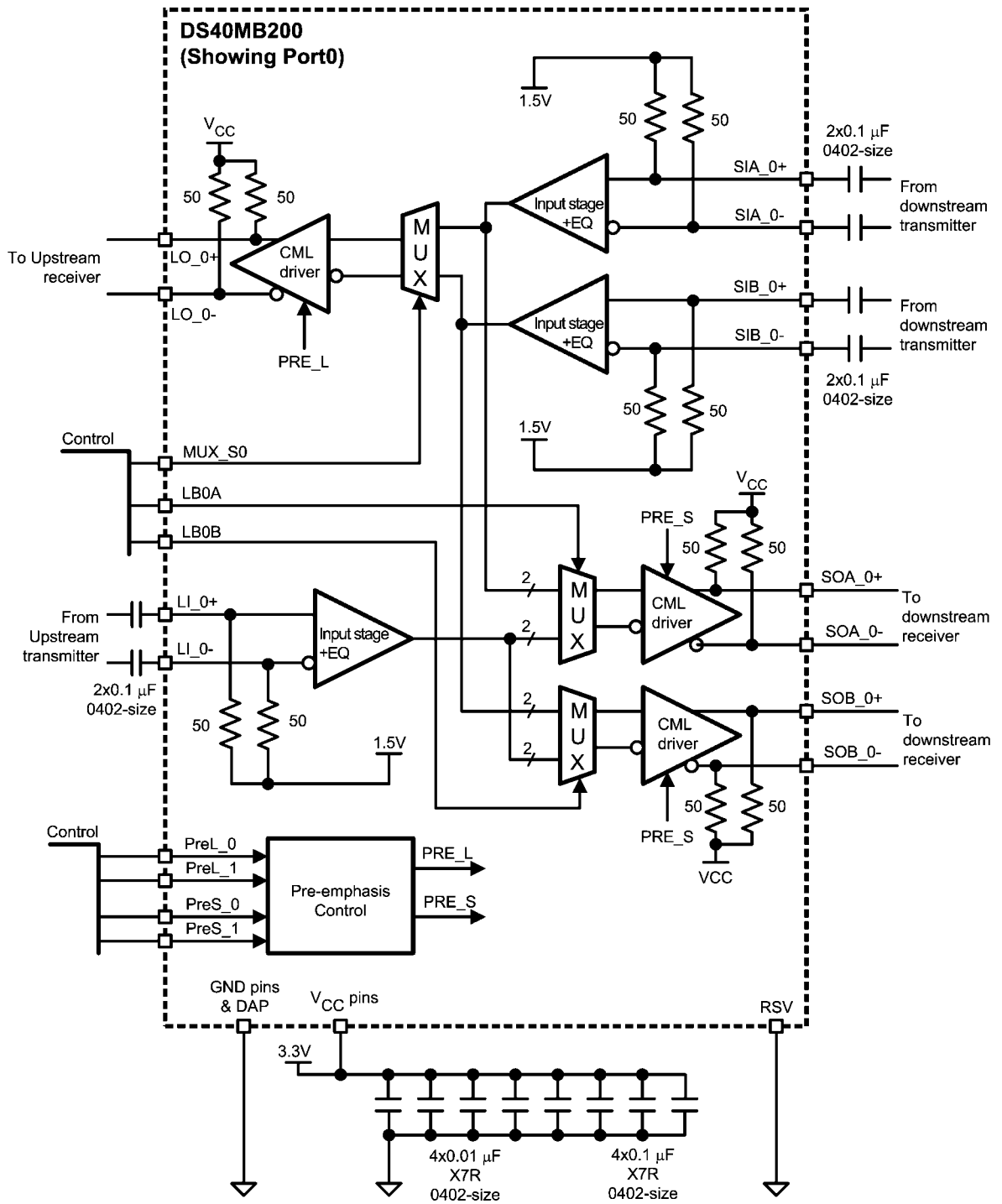

20021740

FIGURE 10. Application diagram (showing data paths of port 0)

Physical Dimensions inches (millimeters) unless otherwise noted

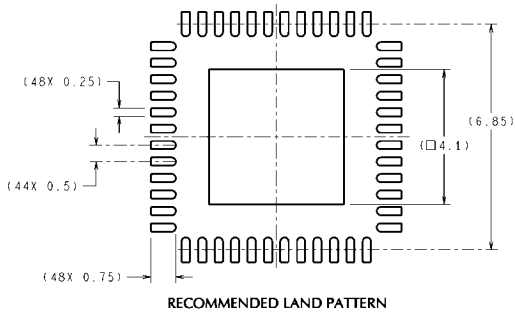

RECOMMENDED LAND PATTERN

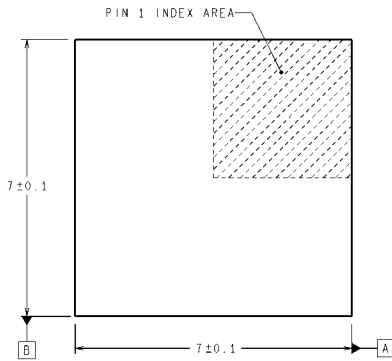

DIMENSIONS ARE IN MILLIMETERS
DIMENSIONS IN () FOR REFERENCE ONLY

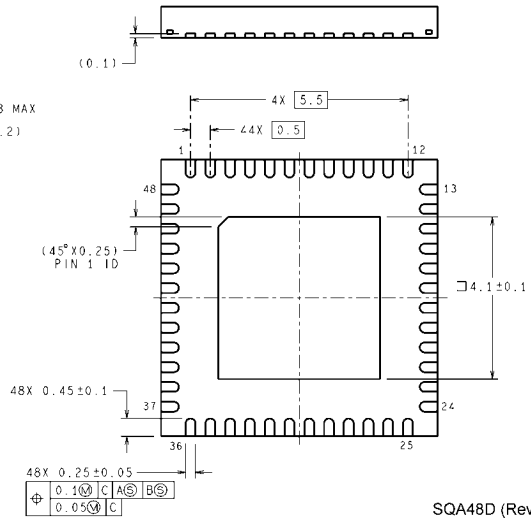
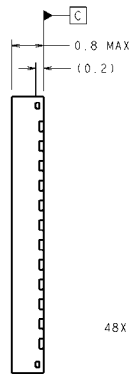

SQA48D (Rev A)

LLP-48 Package
Order number DS40MB200SQ
See NS Package Number SQA48D

Notes

For more National Semiconductor product information and proven design tools, visit the following Web sites at:

Products		Design Support	
Amplifiers	www.national.com/amplifiers	WEBENCH	www.national.com/webench
Audio	www.national.com/audio	Analog University	www.national.com/AU
Clock Conditioners	www.national.com/timing	App Notes	www.national.com/appnotes
Data Converters	www.national.com/adc	Distributors	www.national.com/contacts
Displays	www.national.com/displays	Green Compliance	www.national.com/quality/green
Ethernet	www.national.com/ethernet	Packaging	www.national.com/packaging
Interface	www.national.com/interface	Quality and Reliability	www.national.com/quality
LVDS	www.national.com/lvds	Reference Designs	www.national.com/refdesigns
Power Management	www.national.com/power	Feedback	www.national.com/feedback
Switching Regulators	www.national.com/switchers		
LDOs	www.national.com/ldo		
LED Lighting	www.national.com/led		
PowerWise	www.national.com/powerwise		
Serial Digital Interface (SDI)	www.national.com/sdi		
Temperature Sensors	www.national.com/tempsensors		
Wireless (PLL/VCO)	www.national.com/wireless		

THE CONTENTS OF THIS DOCUMENT ARE PROVIDED IN CONNECTION WITH NATIONAL SEMICONDUCTOR CORPORATION ("NATIONAL") PRODUCTS. NATIONAL MAKES NO REPRESENTATIONS OR WARRANTIES WITH RESPECT TO THE ACCURACY OR COMPLETENESS OF THE CONTENTS OF THIS PUBLICATION AND RESERVES THE RIGHT TO MAKE CHANGES TO SPECIFICATIONS AND PRODUCT DESCRIPTIONS AT ANY TIME WITHOUT NOTICE. NO LICENSE, WHETHER EXPRESS, IMPLIED, ARISING BY ESTOPPEL OR OTHERWISE, TO ANY INTELLECTUAL PROPERTY RIGHTS IS GRANTED BY THIS DOCUMENT.

TESTING AND OTHER QUALITY CONTROLS ARE USED TO THE EXTENT NATIONAL DEEMS NECESSARY TO SUPPORT NATIONAL'S PRODUCT WARRANTY. EXCEPT WHERE MANDATED BY GOVERNMENT REQUIREMENTS, TESTING OF ALL PARAMETERS OF EACH PRODUCT IS NOT NECESSARILY PERFORMED. NATIONAL ASSUMES NO LIABILITY FOR APPLICATIONS ASSISTANCE OR BUYER PRODUCT DESIGN. BUYERS ARE RESPONSIBLE FOR THEIR PRODUCTS AND APPLICATIONS USING NATIONAL COMPONENTS. PRIOR TO USING OR DISTRIBUTING ANY PRODUCTS THAT INCLUDE NATIONAL COMPONENTS, BUYERS SHOULD PROVIDE ADEQUATE DESIGN, TESTING AND OPERATING SAFEGUARDS.

EXCEPT AS PROVIDED IN NATIONAL'S TERMS AND CONDITIONS OF SALE FOR SUCH PRODUCTS, NATIONAL ASSUMES NO LIABILITY WHATSOEVER, AND NATIONAL DISCLAIMS ANY EXPRESS OR IMPLIED WARRANTY RELATING TO THE SALE AND/OR USE OF NATIONAL PRODUCTS INCLUDING LIABILITY OR WARRANTIES RELATING TO FITNESS FOR A PARTICULAR PURPOSE, MERCHANTABILITY, OR INFRINGEMENT OF ANY PATENT, COPYRIGHT OR OTHER INTELLECTUAL PROPERTY RIGHT.

LIFE SUPPORT POLICY

NATIONAL'S PRODUCTS ARE NOT AUTHORIZED FOR USE AS CRITICAL COMPONENTS IN LIFE SUPPORT DEVICES OR SYSTEMS WITHOUT THE EXPRESS PRIOR WRITTEN APPROVAL OF THE CHIEF EXECUTIVE OFFICER AND GENERAL COUNSEL OF NATIONAL SEMICONDUCTOR CORPORATION. As used herein:

Life support devices or systems are devices which (a) are intended for surgical implant into the body, or (b) support or sustain life and whose failure to perform when properly used in accordance with instructions for use provided in the labeling can be reasonably expected to result in a significant injury to the user. A critical component is any component in a life support device or system whose failure to perform can be reasonably expected to cause the failure of the life support device or system or to affect its safety or effectiveness.

National Semiconductor and the National Semiconductor logo are registered trademarks of National Semiconductor Corporation. All other brand or product names may be trademarks or registered trademarks of their respective holders.

Copyright© 2008 National Semiconductor Corporation

For the most current product information visit us at www.national.com



**National Semiconductor
Americas Technical
Support Center**
Email:
new.feedback@nsc.com
Tel: 1-800-272-9959

**National Semiconductor Europe
Technical Support Center**
Email: europe.support@nsc.com
German Tel: +49 (0) 180 5010 771
English Tel: +44 (0) 870 850 4288

**National Semiconductor Asia
Pacific Technical Support Center**
Email: ap.support@nsc.com

**National Semiconductor Japan
Technical Support Center**
Email: jpn.feedback@nsc.com