

DS89C387

Twelve Channel CMOS Differential Line Driver

General Description

The DS89C387 is a high speed twelve channel CMOS differential driver that meets the requirements of TIA/EIA-422-B. The DS89C387 features a low I_{CC} specification of 1.5 mA maximum, which makes it ideal for battery powered and power conscious applications. The device replaces three DS34C87s and offers a PC board space savings up to 30%. The twelve channel driver is available in a SSOP package. The device is ideal for wide parallel bus applications.

Each TRI-STATE® enable (EN) allows the driver outputs to be active or in a HI-impedance off state. Each enable is common to only two drivers for flexibility and control. The drivers may be disabled to turn off load current and to save power when data is not being transmitted.

The driver's input (DI) is compatible with both TTL and CMOS signal levels.

Features

- Low power I_{CC} : 1.5 mA maximum
- Meets TIA/EIA-422-B (RS-422)
- Guaranteed AC parameters:
 - Maximum driver skew -3 ns
 - Maximum transition time -10 ns
- Available in SSOP packaging:
 - Requires 30% less PCB space than 3 DS34C87TMs

Connection Diagram

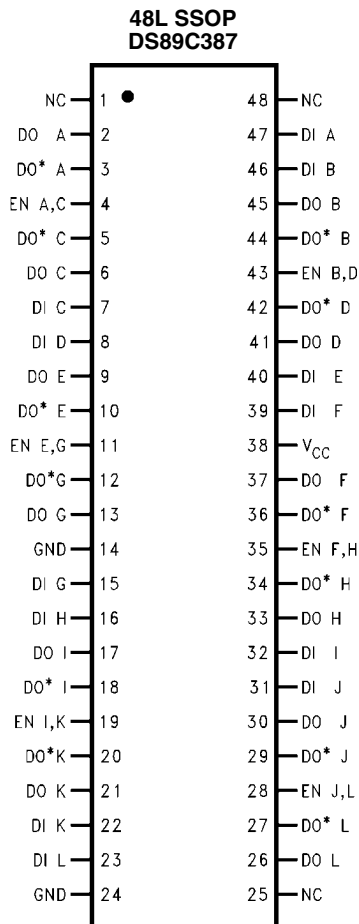

1208601
Order Number DS89C387TMEA
See NS Package Number MS48A

Functional Diagram

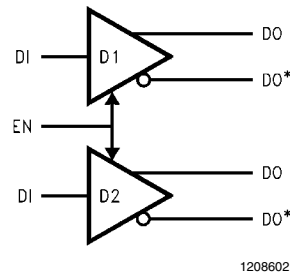

1/6 of package

Truth Table

Enable	Input	Outputs	
		DO	DO*
L	X	Z	Z
H	H	H	L
H	L	L	H

Absolute Maximum Ratings (Notes 1, 2)

If Military/Aerospace specified devices are required, please contact the National Semiconductor Sales Office/ Distributors for availability and specifications.

Supply Voltage (V_{CC})	-0.5 to 7.0V
DC Voltage (V_{IN})	-1.5 to V_{CC} +1.5V
DC Output Voltage (V_{OUT})	-0.5 to 7V
Clamp Diode Current (I_{IK} , I_{OK})	± 20 mA
DC Output Current, per pin (I_{OUT})	± 150 mA
DC V_{CC} or GND Current (I_{CC})	± 500 mA
Storage Temperature Range (T_{STG})	-65°C to +150°C
Junction Temperature	+150°C
Maximum Power Dissipation (P_D) @ 25°C (Note 3)	
SSOP Package	1359 mW
Thermal Resistance	

θ_{JA}	81.7°C/W
θ_{JC}	31.7°C/W
Lead Temperature (T_L) (Soldering 4 sec.)	260°C

This device does not meet 2000V ESD rating. (Note 11)

Operating Conditions

	Min	Max	Units
Supply Voltage (V_{CC})	4.50	5.50	V
DC Input or Output Voltage (V_{IN} , V_{OUT})	0	V_{CC}	V
Operating Temperature Range (T_A)			
DS89C387T	-40	+85	°C
Input Rise or Fall Times (t_r , t_f)		500	ns

DC Electrical Characteristics (Notes 2, 4)

$V_{CC} = 5V \pm 10\%$ (unless otherwise specified)

Symbol	Parameter	Conditions	Min	Typ	Max	Units	
V_{IH}	High Level Input Voltage		2.0		V_{CC}	V	
V_{IL}	Low Level Input Voltage		GND		0.8	V	
V_{OH}	High Level Output Voltage	$V_{IN} = V_{IH}$ or V_{IL} , $I_{OUT} = -20$ mA	2.5	3.4		V	
V_{OL}	Low Level Output Voltage	$V_{IN} = V_{IH}$ or V_{IL} , $I_{OUT} = 48$ mA		0.3	0.5	V	
V_T	Differential Output Voltage	$R_L = 100\Omega$ (Note 5)	2.0	3.1		V	
$ V_T - \bar{V}_T $	Difference In Differential Output	$R_L = 100\Omega$ (Note 5)			0.4	V	
V_{OS}	Common Mode Output Voltage	$R_L = 100\Omega$ (Note 5)		2.0	3.0	V	
$ V_{OS} - \bar{V}_{OS} $	Difference In Common Mode Output	$R_L = 100\Omega$ (Note 5)			0.4	V	
I_{IN}	Input Current	$V_{IN} = V_{CC}$, GND, V_{IH} , or V_{IL}			± 1.0	μA	
I_{CC}	Quiescent Supply Current	$I_{OUT} = 0$ μA , $V_{IN} = V_{CC}$ or GND		600	1500	μA	
		$V_{IN} = 2.4V$ or $0.5V$ (Note 6)		0.8	2.0	mA	
I_{OZ}	TRI-STATE Output Leakage Current	$V_{OUT} = V_{CC}$ or GND Control = V_{IL}		± 0.5	± 5.0	μA	
I_{SC}	Output Short Circuit Current	$V_{IN} = V_{CC}$ or GND (Notes 5, 7)	-30	-115	-150	mA	
I_{OFF}	Power Off Output Leakage Current	$V_{CC} = 0V$ (Note 5)	$V_{OUT} = 6V$			100	μA
			$V_{OUT} = -0.25V$			-100	μA

Note 1: Absolute Maximum Ratings are those values beyond which the safety of the device cannot be guaranteed. They are not meant to imply that the device should be operated at these limits. The table of "Electrical Characteristics" provide conditions for actual device operation.

Note 2: Unless otherwise specified, all voltages are referenced to ground. All currents into device pins are positive; all currents out of device pins are negative.

Note 3: Ratings apply to ambient temperature at 25°C. Above this temperature derate SSOP (MEA) Package 10.9 mW/°C.

Note 4: Unless otherwise specified, min/max limits apply across the -40°C to 85°C temperature range. All typicals are given for $V_{CC} = 5V$ and $T_A = 25^\circ C$.

Note 5: See TIA/EIA-422-B for exact test conditions.

Note 6: Measured per input. All other inputs at V_{CC} or GND.

Switching Characteristics (Note 4)

$V_{CC} = 5V \pm 10\%$, $t_r, t_f \leq 6 \text{ ns}$ (Figures 1, 2, 3, 4)

Symbol	Parameter	Conditions	Min	Typ	Max	Units
t_{PLH}, t_{PHL}	Propagation Delay Input to Output	S1 Open	2	6	11	ns
Skew	(Note 8)	S1 Open	0	0.5	3	ns
t_{TLH}, t_{THL}	Differential Output Rise And Fall Times	S1 Open		6	10	ns
t_{PZH}	Output Enable Time	S1 Closed		12	25	ns
t_{PZL}	Output Enable Time	S1 Closed		13	26	ns
t_{PHZ}	Output Disable Time (Note 9)	S1 Closed		4	8	ns
t_{PLZ}	Output Disable Time (Note 9)	S1 Closed		6	12	ns
C_{PD}	Power Dissipation Capacitance (Note 10)			100		pF
C_{IN}	Input Capacitance			6		pF

Note 7: This is the current sourced when a high output is shorted to ground. Only one output at a time should be shorted.

Note 8: Skew is defined as the difference in propagation delays between complementary outputs at the crossing point.

Note 9: Output disable time is the delay from the control input being switched to the output transistors turning off. The actual disable times are less than indicated due to the delay added by the RC time constant of the load.

Note 10: C_{PD} determines the no load dynamic power consumption, $P_D = C_{PD} V^2 CC f + I_{CC} V_{CC}$, and the no load dynamic current consumption, $I_S = C_{PD} V_{CC} f + I_{CC}$.

Note 11: ESD Rating: HBM (1.5 k Ω , 100 pF)

Inputs $\geq 1500V$

Outputs $\geq 1000V$

EIAJ (0 Ω , 200 pF)

All Pins $\geq 350V$

Logic Diagram

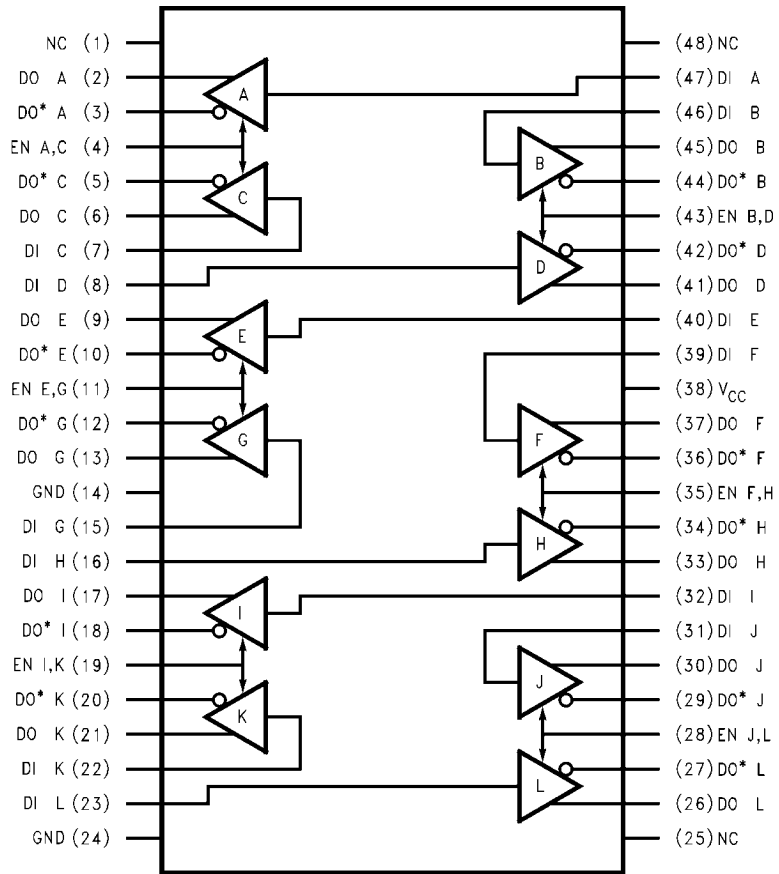

1208603

Parameter Measurement Information

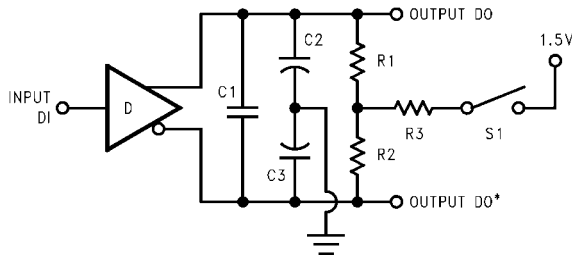

1208604

C1 = C2 = C3 = 40 pF (including Probe and Jig Capacitance), R1 = R2 = 50Ω, R3 = 500Ω

FIGURE 1. AC Test Circuit

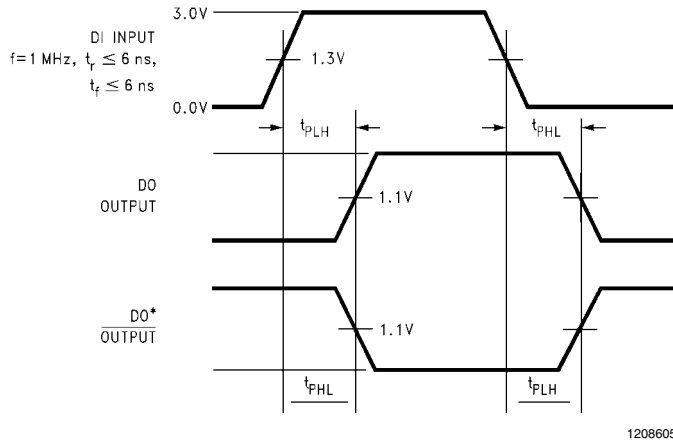

FIGURE 2. Propagation Delays

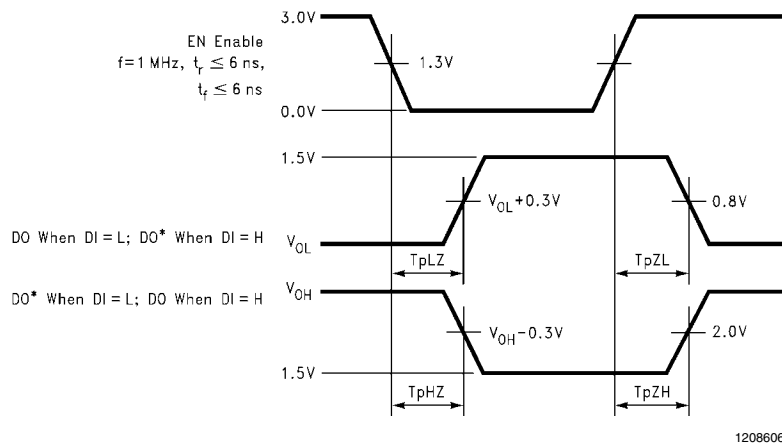
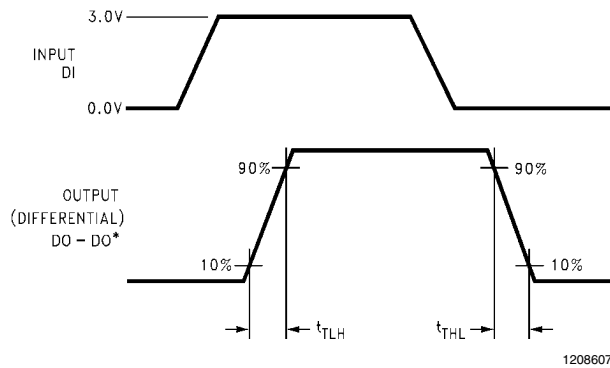

FIGURE 3. Enable and Disable Times



Input pulse; $f = 1 \text{ MHz}$, 50%, $t_r \leq 6 \text{ ns}$, $t_f \leq 6 \text{ ns}$

FIGURE 4. Differential Rise and Fall Times

Typical Application

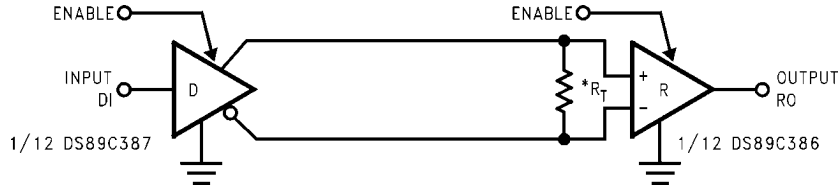

* R_T is optional although highly recommended to reduce reflection.

1208608

FIGURE 5. Two-Wire Balanced System, RS-422

Application Information

SKEW

Skew may be thought of in a lot of different ways, the next few paragraphs should clarify what is represented by "Skew" in the datasheet and how it is determined. Skew, as used in this databook, is the absolute value of a mathematical difference between two propagation delays. This is commonly accepted throughout the semiconductor industry. However, there is no standardized method of measuring propagation delay, from which skew is calculated, of differential line drivers. Elucidating, the voltage level, at which propagation delays are measured, on both input and output waveforms are not always

(Circuit 1)

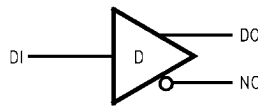

1208609

FIGURE 6. Circuits for Measuring Single-Ended Propagation Delays (See Figure 7)

(Circuit 2)

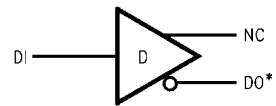

1208610

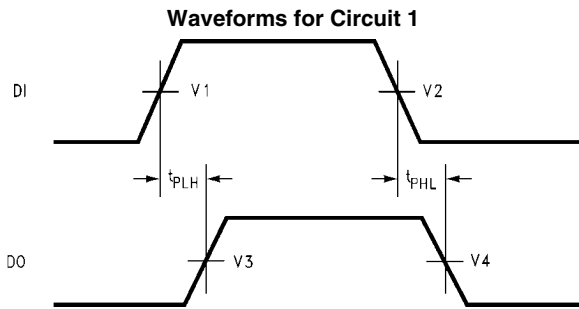

1208611

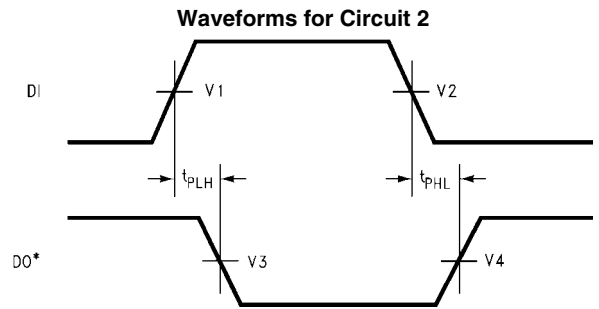

1208612

FIGURE 7. Propagation Delay Waveforms for Circuit 1 and Circuit 2 (See Figure 6)

In Figure 2, V_X , where X is a number, is the waveform voltage level at which the propagation delay measurement either starts or stops. Furthermore, V_1 and V_2 are normally identical. The same is true for V_3 and V_4 . However, as mentioned before, these levels are not standardized and may vary, even with similar devices from other companies. Also note, NC (no connection) in Figure 1 means the pin is not used in propagation delay measurement for the corresponding circuit.

The single-ended skew provides information about the pulse width distortion of the output waveform. The lower the skew, the less the output waveform will be distorted. For best case, skew would be zero, and the output duty cycle would be 50%, assuming the input has a 50% duty cycle.

(Circuit 3)

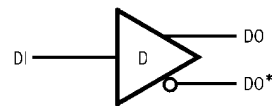

1208613

FIGURE 8. Circuit for Measuring Differential Propagation Delays (See Figure 9)

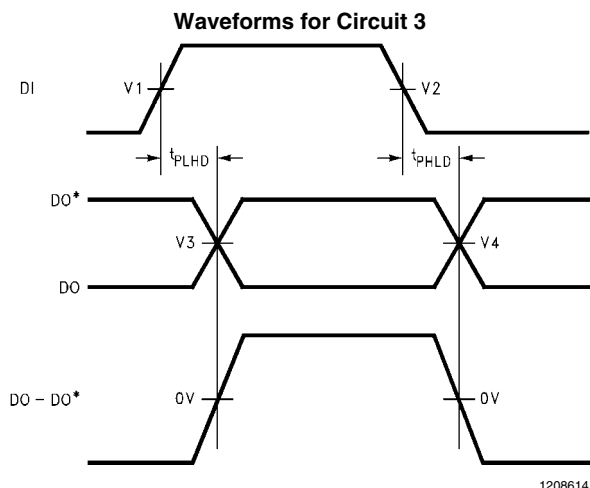

FIGURE 9. Propagation Delay Waveforms for Circuit 3 (See Figure 8)

For differential propagation delays, V1 should equal V2. Furthermore, the crossing point of DO and DO* corresponds to zero volts on the differential waveform (see bottom waveform in Figure 9). This is true whether V3 equals V4 or not. However, if V3 and V4 are specified voltages, then V3 and V4 are less likely to be equal to the crossing point voltage. Thus, the differential propagation delays will not be measured to zero volts on the differential waveform.

The differential skew also provides information about the pulse width distortion of the differential output waveform relative to the input waveform. The higher the skew, the greater the distortion of the differential output waveform. Assuming the input has a 50% duty cycle, the differential output will have a 50% duty cycle if skew equals zero and less than a 50% duty cycle if skew is greater than zero.

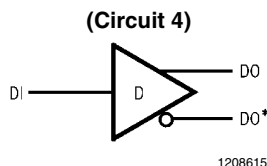

FIGURE 10. Circuit for Measuring Complementary Skew (See Figure 11)

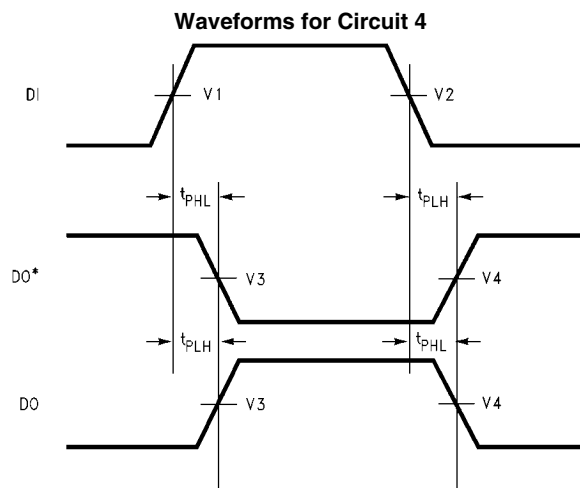

FIGURE 11. Waveforms for Circuit 4 (See Figure 10)

Complementary skew is calculated from single-ended propagation delay measurements on complementary output signals, DO and DO*. Note, when V3 and V4 are absolute values, they are identical on DO and DO*; but vary whenever they are relative values.

The complementary skew reveals information about the contour of the rising and falling edge of the differential output signal of the driver. This is important information because the receiver will interpret the differential output signal. If the differential transitions do not continuously ascend or descend through the receiver's threshold region, errors may occur. Errors may also occur if the transitions are too slow.

In addition, complementary skew provides information about the common mode modulation of the driver. The common mode voltage is represented by $(DO - DO^*)/2$. This information may be used as a means for determining EMI affects.

Only "Skew" is specified in this datasheet for the DS89C387. It refers to the complementary skew of the driver. Complementary skew is measured at both V3 and V4 (see Figure 11).

More information can be calculated from the propagation delays. The channel to channel and device to device skew may be calculated in addition to the types of skew mentioned previously. These parameters provide timing performance information beneficial when designing. The channel to channel skew is calculated from the variation in propagation delay from receiver to receiver within one package. The device to device skew is calculated from the variation in propagation delay from one DS89C387 to another DS89C387.

For the DS89C387, the maximum channel to channel skew is 9 ns ($t_p \text{ max} - t_p \text{ min}$) where t_p is the low to high or high to low propagation delay. The minimum channel to channel skew is 0 ns since it is possible for all 12 drivers to have identical propagation delays. Note, this is best and worst case calculations used whenever Skew (channel) is not independently characterized and specified in the datasheet. The device to device skew may be calculated in the same way and the results are the same. Therefore, the device to device skew is 9 ns and 0 ns maximum and minimum respectively.

TABLE 1. DS89C387 Skew Table

Parameter	Min	Typ	Max	Units
Skew (comp.)	0	0.5	3	ns
Skew (channel)	0		9	ns
Skew (device)	0		9	ns

Note Skew (comp.) in *Table 1* is the same as “Skew” in the datasheet. Also Skew (channel) and Skew (device) are calculations, but are guaranteed by the propagation delay tests. Both Skew (channel) and Skew (device) would normally be tighter whenever specified from characterization data.

The information in this section of the datasheet is to help clarify how skew is defined in this datasheet. This should help when designing the DS89C387 into most applications.

DS89C387 Equivalent Input/Output Circuits

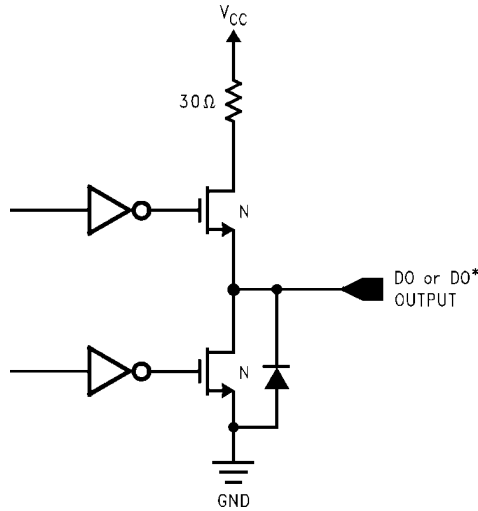

1208617

FIGURE 12. Driver Output Equivalent Circuit

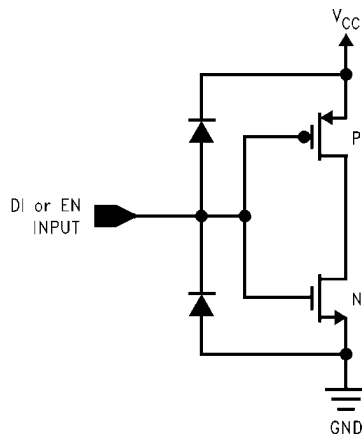

1208618

FIGURE 13. Driver Input or Driver Enable Equivalent Circuit

Pin Descriptions

TABLE 2. Device Pin Names and Descriptions

Pin #	Pin Name	Pin Description
7, 8, 15, 16, 22, 23, 31, 32, 39, 40, 46, 47	DI	TTL/CMOS Compatible Driver Input
2, 6, 9, 13, 17, 21, 26, 30, 33, 37, 41, 45	DO	Non-Inverting Driver Output Pin
3, 5, 10, 12, 18, 20, 27, 29, 34, 36, 44, 44	DO*	Inverting Driver Output Pin
4, 11, 19, 28, 35, 43	EN	Active High Dual Driver Enabling Pin
38	V _{CC}	Positive Power Supply Pin +5 ±10%
14, 24	GND	Device Ground Pin
1, 25, 48	NC	Unused Pin (NOT CONNECTED)

Physical Dimensions inches (millimeters) unless otherwise noted

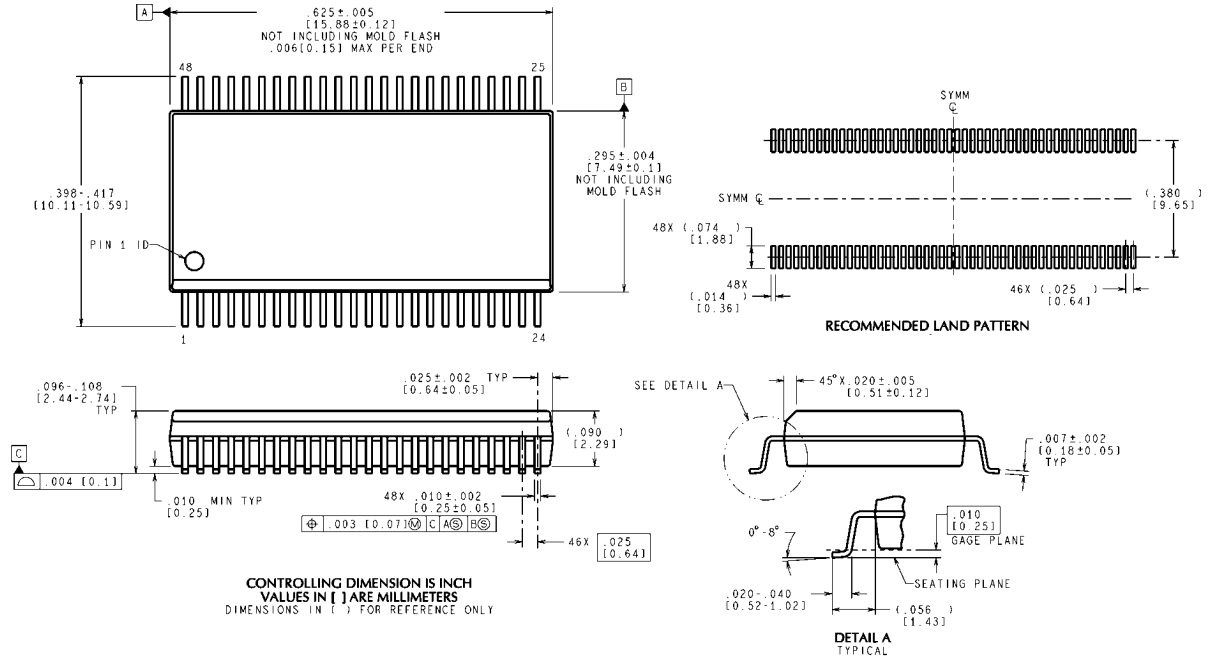

48-Lead (0.300 Wide) Molded Shrink Small Outline Package, JEDEC
Order Number DS89C387TMEA
NS Package Number MS48A

MS48A (Rev F)

Notes

Notes

THE CONTENTS OF THIS DOCUMENT ARE PROVIDED IN CONNECTION WITH NATIONAL SEMICONDUCTOR CORPORATION ("NATIONAL") PRODUCTS. NATIONAL MAKES NO REPRESENTATIONS OR WARRANTIES WITH RESPECT TO THE ACCURACY OR COMPLETENESS OF THE CONTENTS OF THIS PUBLICATION AND RESERVES THE RIGHT TO MAKE CHANGES TO SPECIFICATIONS AND PRODUCT DESCRIPTIONS AT ANY TIME WITHOUT NOTICE. NO LICENSE, WHETHER EXPRESS, IMPLIED, ARISING BY ESTOPPEL OR OTHERWISE, TO ANY INTELLECTUAL PROPERTY RIGHTS IS GRANTED BY THIS DOCUMENT.

TESTING AND OTHER QUALITY CONTROLS ARE USED TO THE EXTENT NATIONAL DEEMS NECESSARY TO SUPPORT NATIONAL'S PRODUCT WARRANTY. EXCEPT WHERE MANDATED BY GOVERNMENT REQUIREMENTS, TESTING OF ALL PARAMETERS OF EACH PRODUCT IS NOT NECESSARILY PERFORMED. NATIONAL ASSUMES NO LIABILITY FOR APPLICATIONS ASSISTANCE OR BUYER PRODUCT DESIGN. BUYERS ARE RESPONSIBLE FOR THEIR PRODUCTS AND APPLICATIONS USING NATIONAL COMPONENTS. PRIOR TO USING OR DISTRIBUTING ANY PRODUCTS THAT INCLUDE NATIONAL COMPONENTS, BUYERS SHOULD PROVIDE ADEQUATE DESIGN, TESTING AND OPERATING SAFEGUARDS.

EXCEPT AS PROVIDED IN NATIONAL'S TERMS AND CONDITIONS OF SALE FOR SUCH PRODUCTS, NATIONAL ASSUMES NO LIABILITY WHATSOEVER, AND NATIONAL DISCLAIMS ANY EXPRESS OR IMPLIED WARRANTY RELATING TO THE SALE AND/OR USE OF NATIONAL PRODUCTS INCLUDING LIABILITY OR WARRANTIES RELATING TO FITNESS FOR A PARTICULAR PURPOSE, MERCHANTABILITY, OR INFRINGEMENT OF ANY PATENT, COPYRIGHT OR OTHER INTELLECTUAL PROPERTY RIGHT.

LIFE SUPPORT POLICY

NATIONAL'S PRODUCTS ARE NOT AUTHORIZED FOR USE AS CRITICAL COMPONENTS IN LIFE SUPPORT DEVICES OR SYSTEMS WITHOUT THE EXPRESS PRIOR WRITTEN APPROVAL OF THE CHIEF EXECUTIVE OFFICER AND GENERAL COUNSEL OF NATIONAL SEMICONDUCTOR CORPORATION. As used herein:

Life support devices or systems are devices which (a) are intended for surgical implant into the body, or (b) support or sustain life and whose failure to perform when properly used in accordance with instructions for use provided in the labeling can be reasonably expected to result in a significant injury to the user. A critical component is any component in a life support device or system whose failure to perform can be reasonably expected to cause the failure of the life support device or system or to affect its safety or effectiveness.

National Semiconductor and the National Semiconductor logo are registered trademarks of National Semiconductor Corporation. All other brand or product names may be trademarks or registered trademarks of their respective holders.

Copyright© 2007 National Semiconductor Corporation

For the most current product information visit us at www.national.com



National Semiconductor Americas Customer Support Center
 Email: new.feedback@nsc.com
 Tel: 1-800-272-9959

National Semiconductor Europe Customer Support Center
 Fax: +49 (0) 180-530-85-86
 Email: europe.support@nsc.com
 Deutsch Tel: +49 (0) 69 9508 6208
 English Tel: +49 (0) 870 24 0 2171
 Français Tel: +33 (0) 1 41 91 8790

National Semiconductor Asia Pacific Customer Support Center
 Email: ap.support@nsc.com

National Semiconductor Japan Customer Support Center
 Fax: 81-3-5639-7507
 Email: jpn.feedback@nsc.com
 Tel: 81-3-5639-7560