

DS90CR218A

+3.3V Rising Edge Data Strobe LVDS 21-Bit Channel Link - 12 MHz to 85 MHz

General Description

The DS90CR218A receiver deserializes three input LVDS data streams into 21 bits of CMOS/TTL output data. When operating at the maximum input clock rate of 85 Mhz, the LVDS data is received at 595 Mbps per data channel for a total data throughput of 1.785 Gbit/sec (233 Mbytes/sec).

The narrow bus and LVDS signalling of the DS90CR218A is an ideal means to solve EMI and cable size problems associated with wide, high-speed TTL interfaces.

Features

- 12 to 85 MHz shift clock support
- 50% duty cycle on receiver output clock
- Low power consumption
- ±1V common-mode range (around +1.2V)
- Narrow bus reduces cable size and cost
- Up to 1.785 Gbps throughput
- Up to 223 Mbytes/sec bandwidth
- 345 mV (typ) swing LVDS devices for low EMI
- PLL requires no external components
- Rising edge data strobe
- Compatible with TIA/EIA-644 LVDS standard
- Low profile 48-lead TSSOP package

Block Diagram

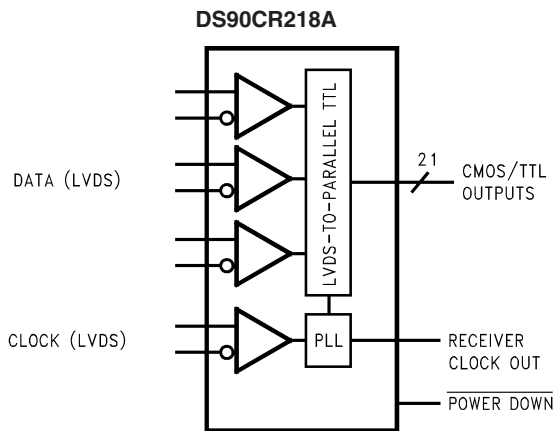

Order Number DS90CR218AMTD
See NS Package Number MTD48

10108027

Connection Diagrams

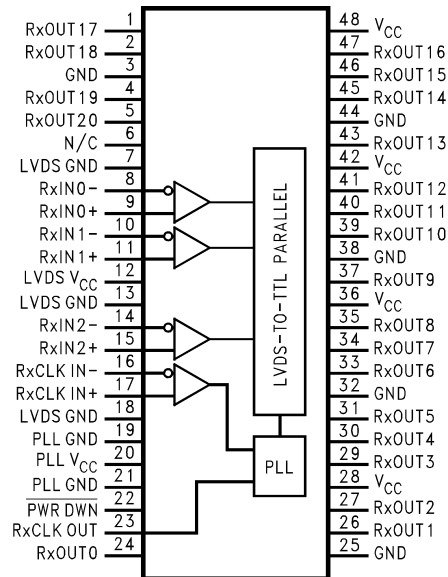

DS90CR218A

10108022

Typical Application

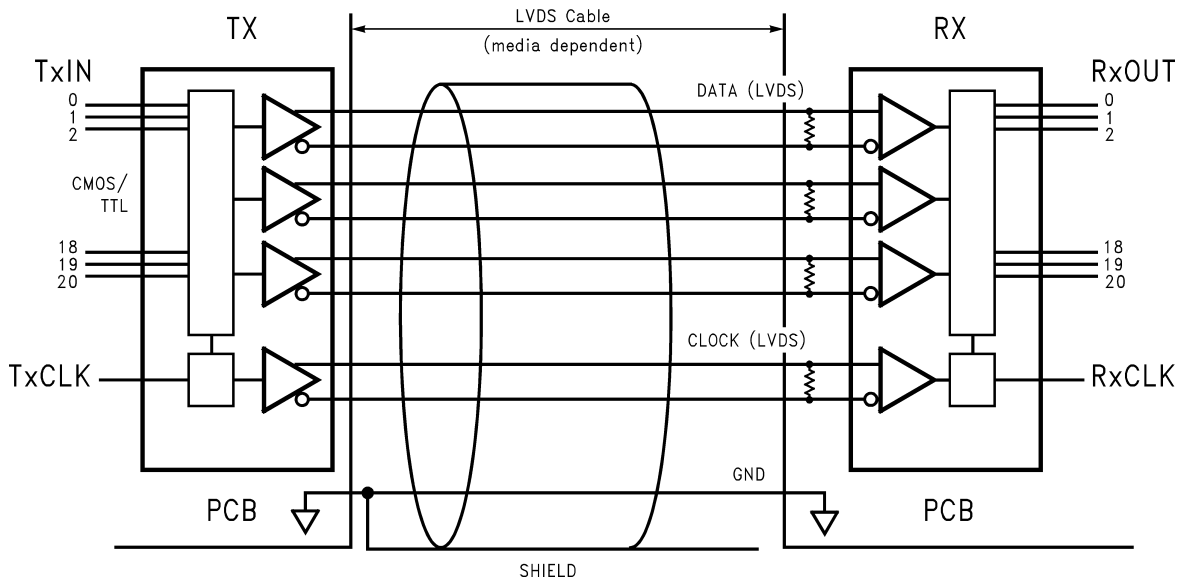

10108023

Absolute Maximum Ratings (Note 1)

If Military/Aerospace specified devices are required, please contact the National Semiconductor Sales Office/Distributors for availability and specifications.

Supply Voltage (V_{CC})	-0.3V to +4V
CMOS/TTL Input Voltage	-0.5V to ($V_{CC} + 0.3V$)
CMOS/TTL Output Voltage	-0.3V to ($V_{CC} + 0.3V$)
LVDS Receiver Input Voltage	-0.3V to ($V_{CC} + 0.3V$)
Junction Temperature	+150°C
Storage Temperature Range	-65°C to +150°C
Lead Temperature	
(Soldering, 4 sec.)	+260°C
Maximum Package Power Dissipation @ +25°C	
MTD48 (TSSOP) Package:	
DS90CR218A	1.89 W
Package Derating	

DS90CR218A 15 mW/°C above +25°C

ESD Rating	
(HBM, 1.5kΩ, 100pF)	> 7kV
(EIAJ, 0Ω, 200pF)	> 700V
Latch Up Tolerance @ 25°C	> ±300mA

Recommended Operating Conditions

	Min	Nom	Max	Units
Supply Voltage (V_{CC})	3.0	3.3	3.6	V
Operating Free Air Temperature (T_A)	-10	+25	+70	°C
Receiver Input Range	0		2.4	V
Supply Noise Voltage (V_{CC})			100	mV _{PP}

Electrical Characteristics

Over recommended operating supply and temperature ranges unless otherwise specified

Symbol	Parameter	Conditions	Min	Typ	Max	Units	
CMOS/TTL DC SPECIFICATIONS							
V_{IH}	High Level Input Voltage		2.0		V_{CC}	V	
V_{IL}	Low Level Input Voltage		GND		0.8	V	
V_{OH}	High Level Output Voltage	$I_{OH} = -0.4$ mA	2.7	3.3		V	
V_{OL}	Low Level Output Voltage	$I_{OL} = 2$ mA		0.06	0.3	V	
V_{CL}	Input Clamp Voltage	$I_{CL} = -18$ mA		-0.79	-1.5	V	
I_{IN}	Input Current	$V_{IN} = 0.4V, 2.5V$ or V_{CC}		+1.8	+15	μA	
		$V_{IN} = GND$	-10	0		μA	
I_{OS}	Output Short Circuit Current	$V_{OUT} = 0V$		-60	-120	mA	
LVDS RECEIVER DC SPECIFICATIONS							
V_{TH}	Differential Input High Threshold	$V_{CM} = +1.2V$			+100	mV	
V_{TL}	Differential Input Low Threshold		-100			mV	
I_{IN}	Input Current	$V_{IN} = +2.4V, V_{CC} = 3.6V$			±10	μA	
		$V_{IN} = 0V, V_{CC} = 3.6V$			±10	μA	
RECEIVER SUPPLY CURRENT							
I_{CCRW}	Receiver Supply Current Worst Case	$C_L = 8$ pF, Worst Case Pattern (<i>Figures 1, 2</i>)	$f = 33$ MHz		49	60	mA
			$f = 40$ MHz		53	65	mA
			$f = 66$ MHz		78	100	mA
			$f = 85$ MHz		90	115	mA
I_{CCRZ}	Receiver Supply Current Power Down	$\overline{PWR\ DWN} = Low$ Receiver Outputs Stay Low during Powerdown Mode			140	400	μA

Note 1: "Absolute Maximum Ratings" are those values beyond which the safety of the device cannot be guaranteed. They are not meant to imply that the device should be operated at these limits. The tables of "Electrical Characteristics" specify conditions for device operation.

Note 2: Typical values are given for $V_{CC} = 3.3V$ and $T_A = +25^\circ C$.

Note 3: Current into device pins is defined as positive. Current out of device pins is defined as negative. Voltages are referenced to ground unless otherwise specified (except V_{OD} and ΔV_{OD}).

Receiver Switching Characteristics

Over recommended operating supply and temperature ranges unless otherwise specified

Symbol	Parameter	Min	Typ	Max	Units	
CLHT	CMOS/TTL Low-to-High Transition Time (Figure 2)		2.0	3.5	ns	
CHLT	CMOS/TTL High-to-Low Transition Time (Figure 2)		1.8	3.5	ns	
RSPos0	Receiver Input Strobe Position for Bit 0 (Figure 8)	f = 85 MHz	0.49	0.84	1.19	ns
RSPos1	Receiver Input Strobe Position for Bit 1		2.17	2.52	2.87	ns
RSPos2	Receiver Input Strobe Position for Bit 2		3.85	4.20	4.55	ns
RSPos3	Receiver Input Strobe Position for Bit 3		5.53	5.88	6.23	ns
RSPos4	Receiver Input Strobe Position for Bit 4		7.21	7.56	7.91	ns
RSPos5	Receiver Input Strobe Position for Bit 5		8.89	9.24	9.59	ns
RSPos6	Receiver Input Strobe Position for Bit 6		10.57	10.92	11.27	ns
RSKM	RxIN Skew Margin (Note 4) (Figure 9)	f = 85 MHz		0.49	ns	
		f = 12MHz		2.01	ns	
RCOP	RxCLK OUT Period (Figure 3)	11.76	T	83.33	ns	
RCOH	RxCLK OUT High Time (Figure 3)	f = 85 MHz	4	5	6.5	ns
RCOL	RxCLK OUT Low Time (Figure 3)		3.5	5	6	ns
RSRC	RxOUT Setup to RxCLK OUT (Figure 3)		3.5			ns
RHRC	RxOUT Hold to RxCLK OUT (Figure 3)		3.5			ns
RCCD	RxCLK IN to RxCLK OUT Delay @ 25°C, V _{CC} = 3.3V (Note 5)(Figure 4)		5.5	7	9.5	ns
RPLLS	Receiver Phase Lock Loop Set (Figure 5)			10	ms	
RPDD	Receiver Powerdown Delay (Figure 7)			1	µs	

Note 4: Receiver Skew Margin is defined as the valid data sampling region at the receiver inputs. This margin takes into account the receiver input setup and hold time (internal data sampling window). This margin do not take into account the Transmitter Pulse Position (TPPOS) variance and is measured using the ideal TPPOS. This margin allows LVDS interconnect skew, inter-symbol interference (both dependent on type/length of cable), Transmitter Pulse Position (TPPOS) variance, and source clock jitter less than 250 ps.

Note 5: Total latency for the channel link chipset is a function of clock period and gate delays through the transmitter (TCCD) and receiver (RCCD). The total latency for the 217/287 transmitter and 218A/288A receiver is: (T + TCCD) + (2*T + RCCD), where T = Clock period.

AC Timing Diagrams

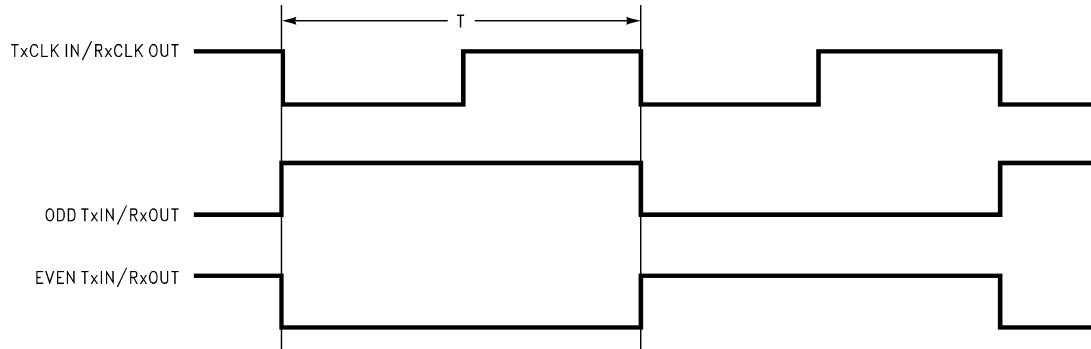

10108002

FIGURE 1. “Worst Case” Test Pattern

AC Timing Diagrams (Continued)

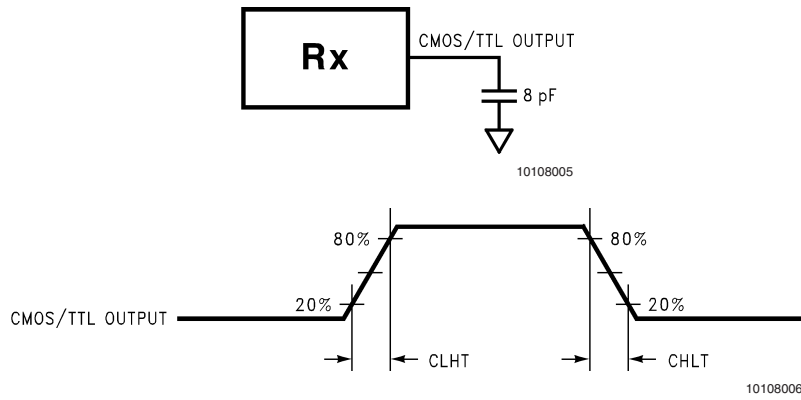

FIGURE 2. DS90CR218A (Receiver) CMOS/TTL Output Load and Transition Times

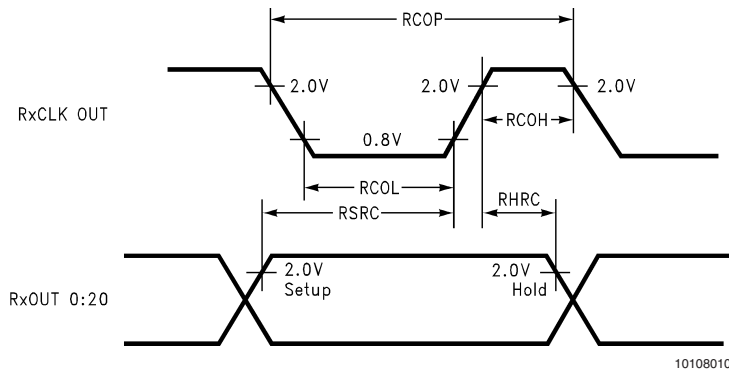

FIGURE 3. DS90CR218A (Receiver) Setup/Hold and High/Low Times

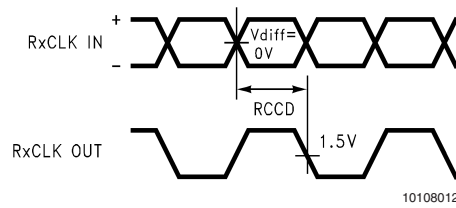

FIGURE 4. DS90CR218A (Receiver) Clock In to Clock Out Delay

AC Timing Diagrams (Continued)

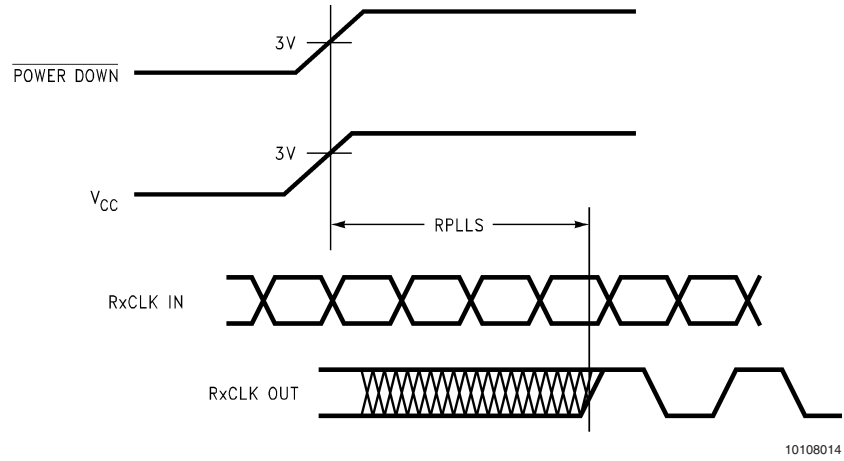

FIGURE 5. DS90CR218A (Receiver) Phase Lock Loop Set Time

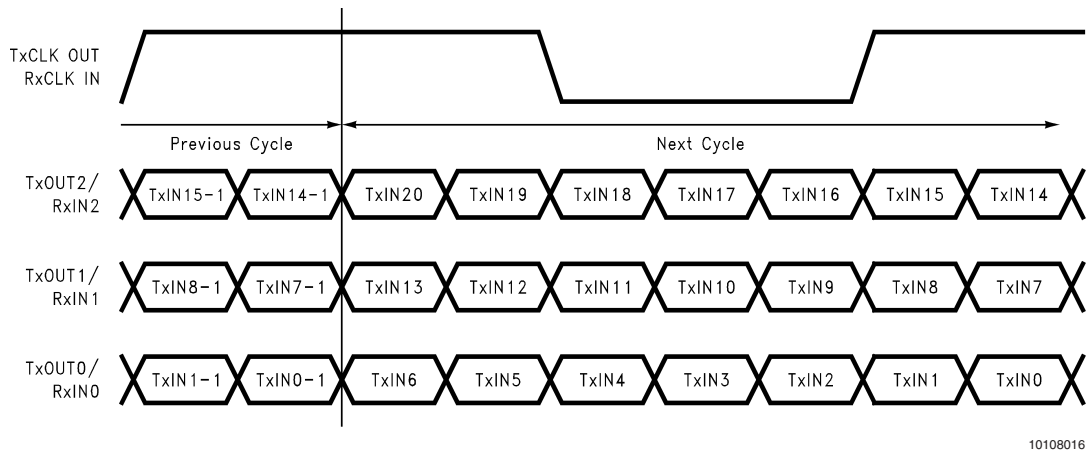

FIGURE 6. 21 Parallel TTL Data Inputs Mapped to LVDS Outputs

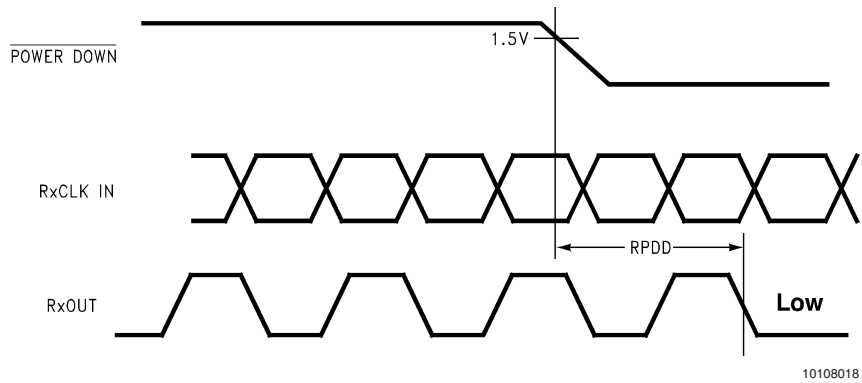
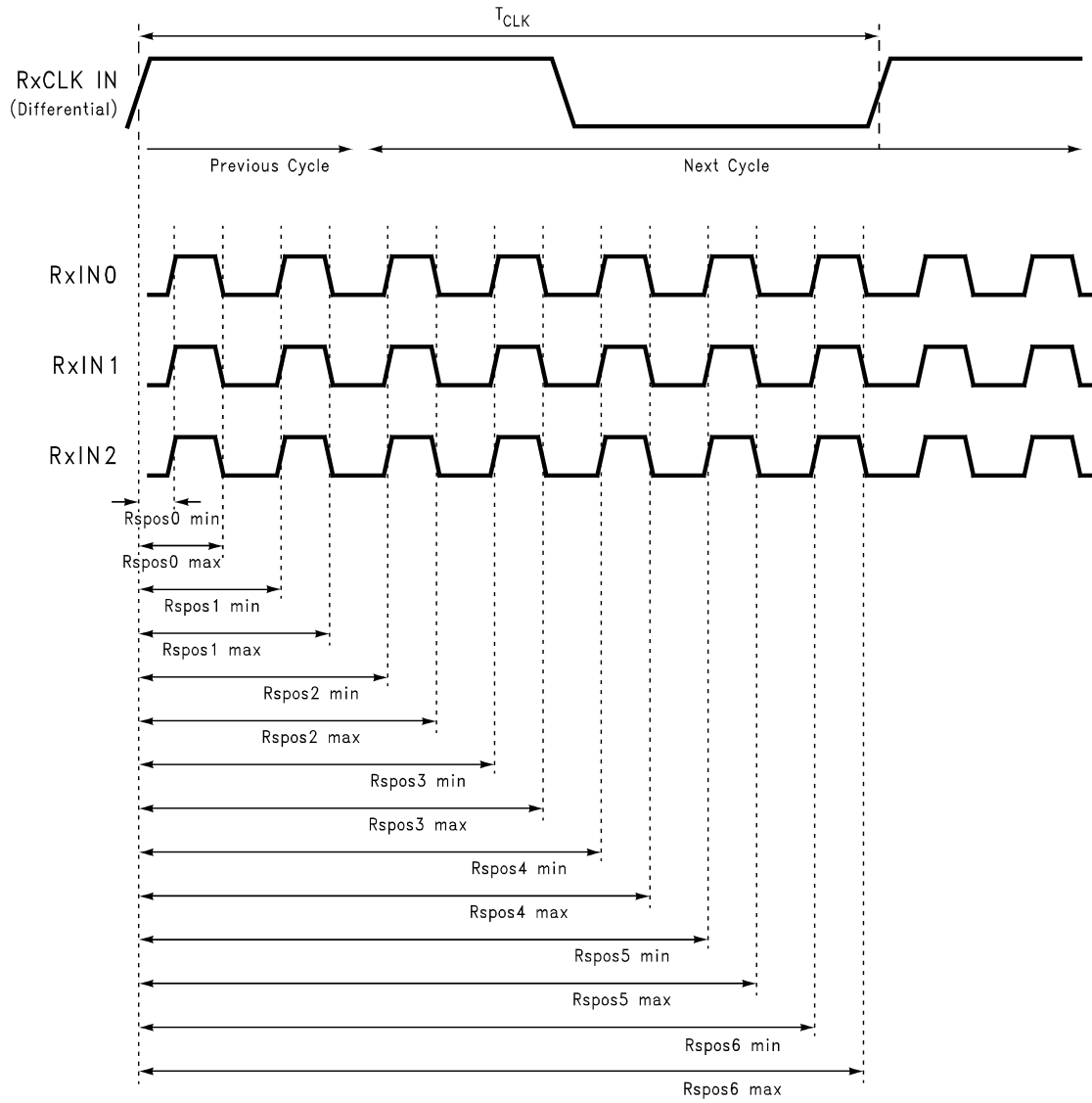

FIGURE 7. Receiver Powerdown Delay

AC Timing Diagrams (Continued)



10108028

FIGURE 8. Receiver LVDS Input Strobe Position

AC Timing Diagrams (Continued)

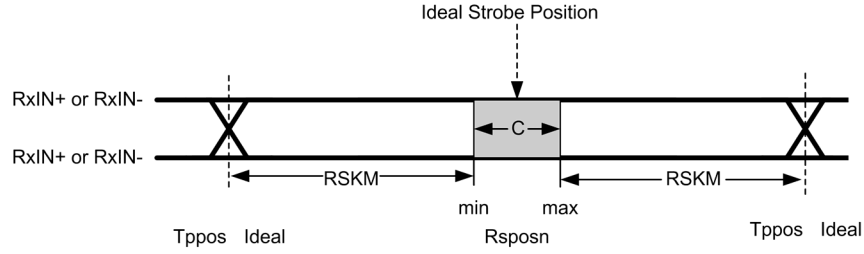

10108020

C — Setup and Hold Time (Internal data sampling window) defined by Rstpos (receiver input strobe position) min and max
 Tppos Ideal — Calculated Transmitter output pulse position
 $RSKM \geq \text{Cable Skew (type, length) + Source Clock Jitter (cycle to cycle) (Note 6) + ISI (Inter-symbol interference) (Note 7) + TPPOS variance (Tx dependent)}$
 Cable Skew — typically 10 ps–40 ps per foot, media dependent
Note 6: Cycle-to-cycle jitter is less than 250 ps at 85MHz
Note 7: ISI is dependent on interconnect length; may be zero

FIGURE 9. Receiver LVDS Input Skew Margin

Applications Information

DS90CR218A Pin Descriptions — Channel Link Receiver

Pin Name	I/O	No.	Description
RxIN+	I	3	Positive LVDS differential data inputs.
RxIN-	I	3	Negative LVDS differential data inputs.
RxOUT	O	21	TTL level data outputs.
RxCLK IN+	I	1	Positive LVDS differential clock input.
RxCLK IN-	I	1	Negative LVDS differential clock input.
RxCLK OUT	O	1	TTL level clock output. The rising edge acts as data strobe. Pin name RxCLK OUT.
PWR DWN	I	1	TTL level input. When asserted (low input) the receiver outputs are low.
V _{CC}	I	4	Power supply pins for TTL outputs.
GND	I	5	Ground pins for TTL outputs.
PLL V _{CC}	I	1	Power supply for PLL.
PLL GND	I	2	Ground pin for PLL.
LVDS V _{CC}	I	1	Power supply pin for LVDS inputs.
LVDS GND	I	3	Ground pins for LVDS inputs.

The Channel Link devices are intended to be used in a wide variety of data transmission applications. Depending upon the application the interconnecting media may vary. For example, for lower data rate (clock rate) and shorter cable lengths (< 2m), the media electrical performance is less critical. For higher speed/long distance applications the media's performance becomes more critical. Certain cable constructions provide tighter skew (matched electrical length between the conductors and pairs). Twin-coax for example, has been demonstrated at distances as great as 5 meters and with the maximum data transfer of 1.785 Gbit/s. Additional applications information can be found in the following National Interface Application Notes:

AN = ####	Topic
AN-1041	Introduction to Channel Link
AN-1108	Channel Link PCB and Interconnect Design-In Guidelines
AN-1109	Multi-Drop Channel-Link Operation
AN-806	Transmission Line Theory
AN-905	Transmission Line Calculations and Differential Impedance
AN-916	Cable Information

Applications Information (Continued)

CABLES

A cable interface between the transmitter and receiver needs to support the differential LVDS pairs. The ideal cable/connector interface would have a constant 100Ω differential impedance throughout the path. It is also recommended that cable skew remain below 90ps (@ 85 MHz clock rate) to maintain a sufficient data sampling window at the receiver.

In addition to the four or five cable pairs that carry data and clock, it is recommended to provide at least one additional conductor (or pair) which connects ground between the transmitter and receiver. This low impedance ground provides a common-mode return path for the two devices. Some of the more commonly used cable types for point-to-point applications include flat ribbon, flex, twisted pair and Twin-Coax. All are available in a variety of configurations and options. Flat ribbon cable, flex and twisted pair generally perform well in short point-to-point applications while Twin-Coax is good for short and long applications. When using ribbon cable, it is recommended to place a ground line between each differential pair to act as a barrier to noise coupling between adjacent pairs. For Twin-Coax cable applications, it is recommended to utilize a shield on each cable pair. All extended point-to-point applications should also employ an overall shield surrounding all cable pairs regardless of the cable type. This overall shield results in improved transmission parameters such as faster attainable speeds, longer distances between transmitter and receiver and reduced problems associated with EMS or EMI.

The high-speed transport of LVDS signals has been demonstrated on several types of cables with excellent results. However, the best overall performance has been seen when using Twin-Coax cable. Twin-Coax has very low cable skew and EMI due to its construction and double shielding. All of the design considerations discussed here and listed in the supplemental application notes provide the subsystem communications designer with many useful guidelines. It is recommended that the designer assess the tradeoffs of each application thoroughly to arrive at a reliable and economical cable solution.

RECEIVER FAILSAFE FEATURE

These receivers have input failsafe bias circuitry to guarantee a stable receiver output for floating or terminated receiver inputs. Under these conditions receiver inputs will be in a HIGH state. If a clock signal is present, data outputs will

all be HIGH; if the clock input is also floating/terminated, data outputs will remain in the last valid state. A floating/terminated clock input will result in a HIGH clock output.

BOARD LAYOUT

To obtain the maximum benefit from the noise and EMI reductions of LVDS, attention should be paid to the layout of differential lines. Lines of a differential pair should always be adjacent to eliminate noise interference from other signals and take full advantage of the noise canceling of the differential signals. The board designer should also try to maintain equal length on signal traces for a given differential pair. As with any high-speed design, the impedance discontinuities should be limited (reduce the numbers of vias and no 90 degree angles on traces). Any discontinuities which do occur on one signal line should be mirrored in the other line of the differential pair. Care should be taken to ensure that the differential trace impedance match the differential impedance of the selected physical media (this impedance should also match the value of the termination resistor that is connected across the differential pair at the receiver's input). Finally, the location of the CHANNEL LINK TxOUT/RxIN pins should be as close as possible to the board edge so as to eliminate excessive pcb runs. All of these considerations will limit reflections and crosstalk which adversely effect high frequency performance and EMI.

UNUSED INPUTS

All unused outputs at the RxOUT outputs of the receiver must then be left floating.

TERMINATION

Use of current mode drivers requires a terminating resistor across the receiver inputs. The CHANNEL LINK chipset will normally require a single 100Ω resistor between the true and complement lines on each differential pair of the receiver input. The actual value of the termination resistor should be selected to match the differential mode characteristic impedance (90Ω to 120Ω typical) of the cable. *Figure 10* shows an example. No additional pull-up or pull-down resistors are necessary as with some other differential technologies such as PECL. Surface mount resistors are recommended to avoid the additional inductance that accompanies leaded resistors. These resistors should be placed as close as possible to the receiver input pins to reduce stubs and effectively terminate the differential lines.

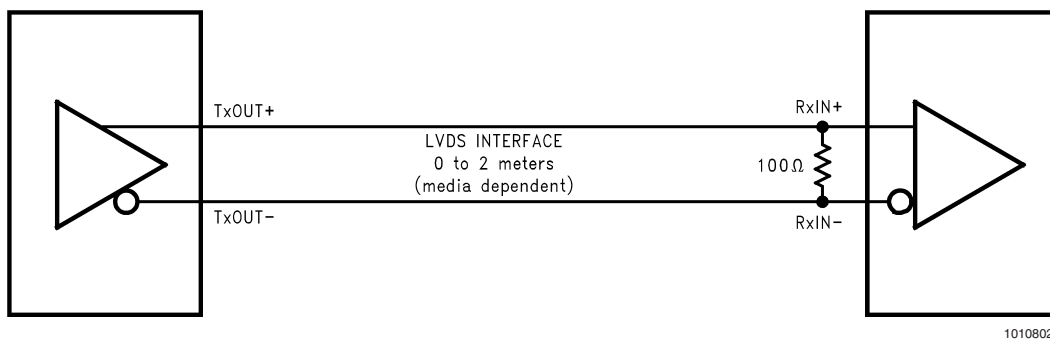
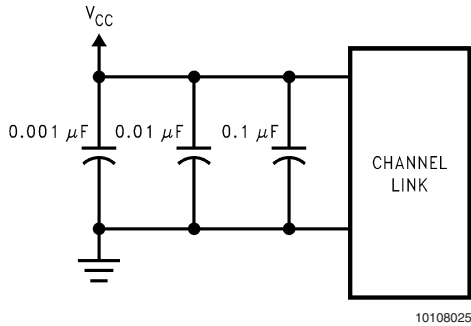

FIGURE 10. LVDS Serialized Link Termination

Applications Information (Continued)

DECOUPLING CAPACITORS

Bypassing capacitors are needed to reduce the impact of switching noise which could limit performance. For a conservative approach three parallel-connected decoupling capacitors (Multi-Layered Ceramic type in surface mount form factor) between each V_{CC} and the ground plane(s) are recommended. The three capacitor values are 0.1 μF , 0.01 μF and 0.001 μF . An example is shown in *Figure 11*. The designer should employ wide traces for power and ground and ensure each capacitor has its own via to the ground plane. If board space is limiting the number of bypass capacitors, the PLL V_{CC} should receive the most filtering/bypassing. Next would be the LVDS V_{CC} pins and finally the logic V_{CC} pins.



**FIGURE 11. CHANNEL LINK
Decoupling Configuration**

CLOCK JITTER

The CHANNEL LINK devices employ a PLL to generate and recover the clock transmitted across the LVDS interface. The width of each bit in the serialized LVDS data stream is one-seventh the clock period. For example, a 85 MHz clock has a period of 11.76 ns which results in a data bit width of 1.68 ns. Differential skew (Δt within one differential pair), interconnect skew (Δt of one differential pair to another) and clock jitter will all reduce the available window for sampling the LVDS serial data streams. Care must be taken to ensure that the clock input to the transmitter be a clean low noise signal. Individual bypassing of each V_{CC} to ground will minimize the noise passed on to the PLL, thus creating a low jitter LVDS clock. These measures provide more margin for channel-to-channel skew and interconnect skew as a part of the overall jitter/skew budget.

COMMON-MODE vs. DIFFERENTIAL MODE NOISE MARGIN

The typical signal swing for LVDS is 300 mV centered at +1.2V. The CHANNEL LINK receiver supports a 100 mV threshold therefore providing approximately 200 mV of differential noise margin. Common-mode protection is of more importance to the system's operation due to the differential data transmission. LVDS supports an input voltage range of Ground to +2.4V. This allows for a $\pm 1.0\text{V}$ shifting of the center point due to ground potential differences and common-mode noise.

Physical Dimensions inches (millimeters) unless otherwise noted

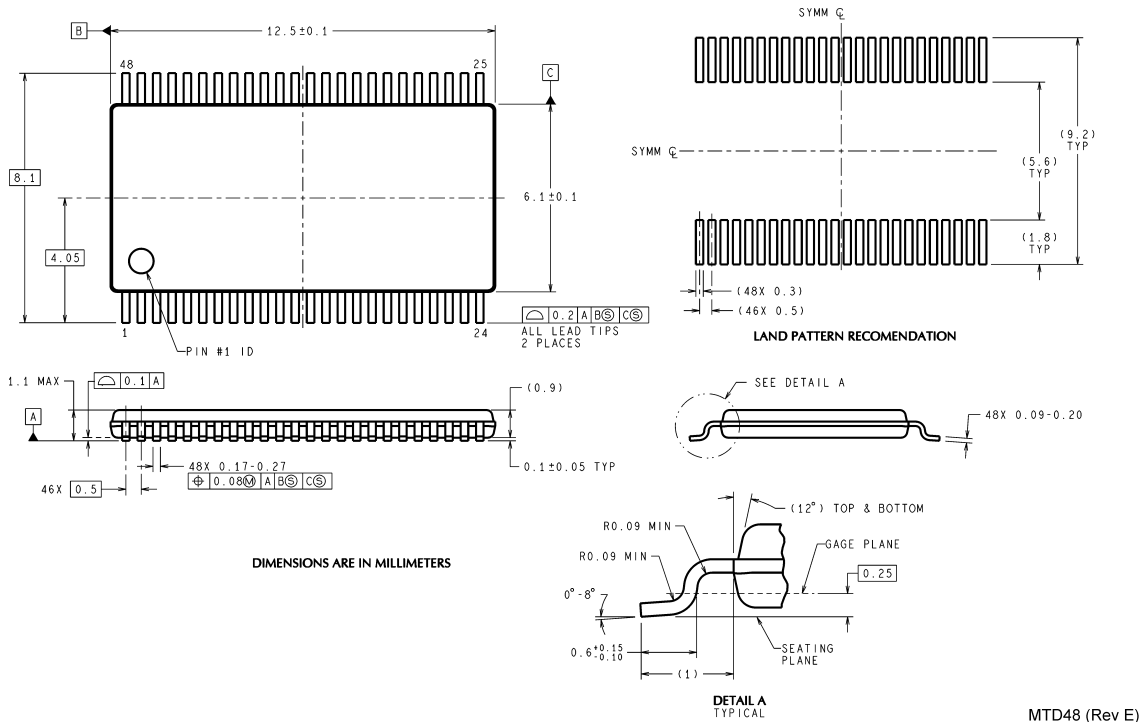

Order Number DS90CR218AMTD
Dimensions in millimeters only
NS Package Number MTD48

National does not assume any responsibility for use of any circuitry described, no circuit patent licenses are implied and National reserves the right at any time without notice to change said circuitry and specifications.
 For the most current product information visit us at www.national.com.

LIFE SUPPORT POLICY

NATIONAL'S PRODUCTS ARE NOT AUTHORIZED FOR USE AS CRITICAL COMPONENTS IN LIFE SUPPORT DEVICES OR SYSTEMS WITHOUT THE EXPRESS WRITTEN APPROVAL OF THE PRESIDENT AND GENERAL COUNSEL OF NATIONAL SEMICONDUCTOR CORPORATION. As used herein:

1. Life support devices or systems are devices or systems which, (a) are intended for surgical implant into the body, or (b) support or sustain life, and whose failure to perform when properly used in accordance with instructions for use provided in the labeling, can be reasonably expected to result in a significant injury to the user.
2. A critical component is any component of a life support device or system whose failure to perform can be reasonably expected to cause the failure of the life support device or system, or to affect its safety or effectiveness.

BANNED SUBSTANCE COMPLIANCE

National Semiconductor follows the provisions of the Product Stewardship Guide for Customers (CSP-9-111C2) and Banned Substances and Materials of Interest Specification (CSP-9-111S2) for regulatory environmental compliance. Details may be found at: www.national.com/quality/green.

Lead free products are RoHS compliant.



National Semiconductor
Americas Customer Support Center
 Email: new.feedback@nsc.com
 Tel: 1-800-272-9959

National Semiconductor
Europe Customer Support Center
 Fax: +49 (0) 180-530 85 86
 Email: europe.support@nsc.com
 Deutsch Tel: +49 (0) 69 9508 6208
 English Tel: +44 (0) 870 24 0 2171
 Français Tel: +33 (0) 1 41 91 8790

National Semiconductor
Asia Pacific Customer Support Center
 Email: ap.support@nsc.com

National Semiconductor
Japan Customer Support Center
 Fax: 81-3-5639-7507
 Email: jpn.feedback@nsc.com
 Tel: 81-3-5639-7560