

DS90LV804

4-Channel 800 Mbps LVDS Buffer/Repeater

General Description

The DS90LV804 is a four channel 800 Mbps LVDS buffer/repeater. In many large systems, signals are distributed across cables and signal integrity is highly dependent on the data rate, cable type, length, and the termination scheme. In order to maximize signal integrity, the DS90LV804 features both an internal input and output (source) termination to eliminate these extra components from the board, and to also place the terminations as close as possible to receiver inputs and driver output. This is especially significant when driving longer cables.

The DS90LV804, available in the LLP (Leadless Leadframe Package) package, minimizes the footprint, and improves system performance.

An output enable pin is provided, which allows the user to place the LVDS outputs and internal biasing generators in a TRI-STATE, low power mode.

The differential inputs interface to LVDS, and Bus LVDS signals such as those on National's 10-, 16-, and 18- bit Bus LVDS SerDes, as well as CML and LVPECL. The differential inputs are internally terminated with a 100Ω resistor to improve performance and minimize board space. This function is especially useful for boosting signals over lossy cables or point-to-point backplane configurations.

Features

- 800 Mbps data rate per channel
- Low output skew and jitter
- Hot plug protection
- LVDS/CML/LVPECL compatible input, LVDS output
- On-chip 100Ω input and output termination
- 12 kV ESD protection on LVDS Outputs
- Single 3.3V supply
- Very low power consumption
- Industrial -40 to +85°C temperature range
- Small LLP Package Footprint

Typical Application

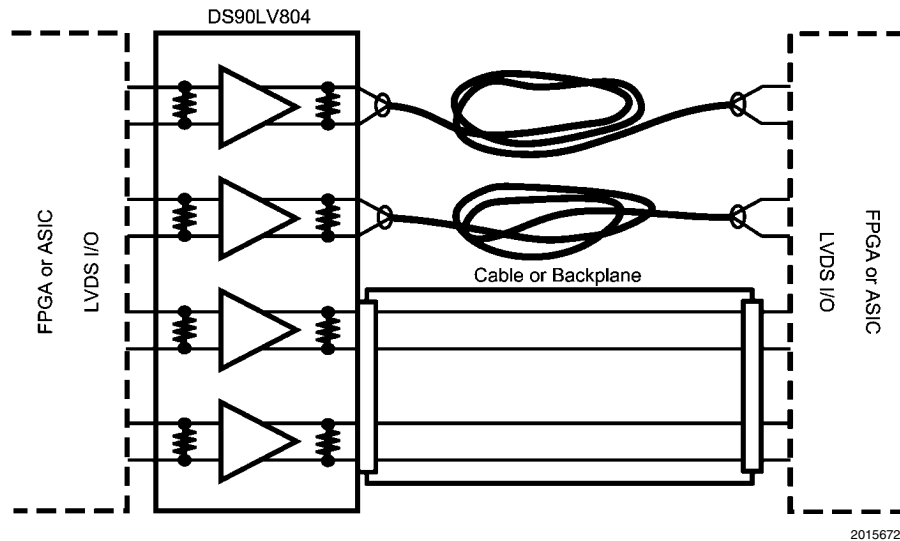

Block and Connection Diagrams

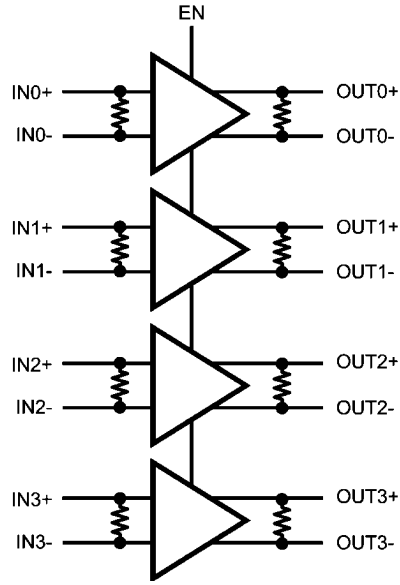

DS90LV804 Block Diagram

20156701

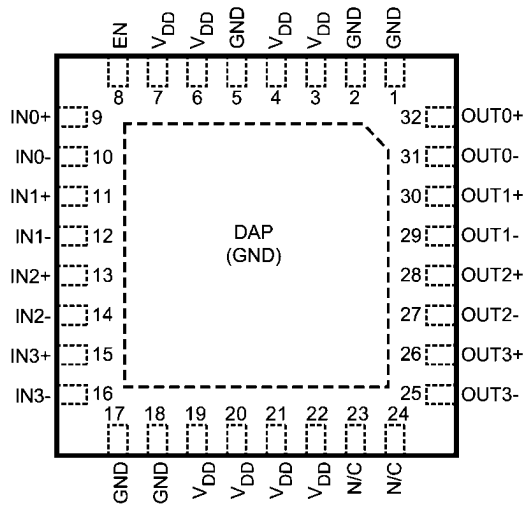

DS90LV804 LLP Pinout (Top View)

20156702

Pin Descriptions

Pin Name	LLP Pin Number	I/O, Type	Description
DIFFERENTIAL INPUTS			
IN0+	9	I, LVDS	Channel 0 inverting and non-inverting differential inputs.
IN0-	10		
IN1+	11	I, LVDS	Channel 1 inverting and non-inverting differential inputs.
IN1-	12		
IN2+	13	I, LVDS	Channel 2 inverting and non-inverting differential inputs.
IN2-	14		
IN3+	15	I, LVDS	Channel 3 inverting and non-inverting differential inputs.
IN3-	16		
DIFFERENTIAL OUTPUTS			
OUT0+	32	O, LVDS	Channel 0 inverting and non-inverting differential outputs. (Note 2)
OUT0-	31		
OUT1+	30	O, LVDS	Channel 1 inverting and non-inverting differential outputs. (Note 2)
OUT1-	29		
OUT2+	28	O, LVDS	Channel 2 inverting and non-inverting differential outputs. (Note 2)
OUT2-	27		
OUT3+	26	O, LVDS	Channel 3 inverting and non-inverting differential outputs. (Note 2)
OUT3-	25		
DIGITAL CONTROL INTERFACE			
EN	8	I, LVTTTL	Enable pin. When EN is LOW, the driver is disabled and the LVDS outputs are in TRI-STATE. When EN is HIGH, the driver is enabled. LVCMOS/LVTTTL level input.
POWER			
V _{DD}	3, 4, 6, 7, 19, 20, 21, 22	I, Power	V _{DD} = 3.3V, ±5%
GND	1, 2, 5, 17, 18 (Note 1)	I, Power	Ground reference for LVDS and CMOS circuitry. For the LLP package, the DAP is used as the primary GND connection to the device. The DAP is the exposed metal contact at the bottom of the LLP-32 package. It should be connected to the ground plane with at least 4 vias for optimal AC and thermal performance. The pin numbers listed should also be tied to ground for proper biasing.
N/C	23, 24		No Connect

Note 1: Note that for the LLP package the GND is connected thru the DAP on the back side of the LLP package in addition to grounding actual pins on the package as listed.

Note 2: The LVDS outputs do not support a multidrop (BLVDS) environment. The LVDS output characteristics of the DS90LV804 device have been optimized for point-to-point backplane and cable applications.

Absolute Maximum Ratings (Note 3)

Supply Voltage (V_{DD})	-0.3V to +4.0V
CMOS Input Voltage (EN)	-0.3V to ($V_{DD}+0.3V$)
LVDS Input Voltage (Note 4)	-0.3V to ($V_{DD}+0.3V$)
LVDS Output Voltage	-0.3V to ($V_{DD}+0.3V$)
LVDS Output Short Circuit Current	+90 mA
Junction Temperature	+150°C
Storage Temperature	-65°C to +150°C
Lead Temperature (Solder, 4sec)	260°C
Max Pkg Power Capacity @ 25°C	4.16W
Thermal Resistance	
θ_{JA}	29.5°C/W
θ_{JC}	3.5°C/W
Package Derating above +25°C	33.3mW/°C
ESD Last Passing Voltage (LVDS output pins)	
HBM, 1.5k Ω , 100pF	12 kV
EIAJ, 0 Ω , 200pF	250V
Charged Device Model	1000V

ESD Last Passing Voltage (All other pins)

HBM, 1.5k Ω , 100pF	8 kV
EIAJ, 0 Ω , 200pF	250V
Charged Device Model	1000V

Recommended Operating Conditions

Supply Voltage (V_{CC})	3.15V to 3.45V
Input Voltage (V_i) (Note 4)	0V to V_{DD}
Output Voltage (V_o)	0V to V_{DD}
Operating Temperature (T_A)	
Industrial	-40°C to +85°C

Note 3: Absolute maximum ratings are those values beyond which damage to the device may occur. The databook specifications should be met, without exception, to ensure that the system design is reliable over its power supply, temperature, and output/input loading variables. National does not recommend operation of products outside of recommended operation conditions.

Note 4: $V_{ID\ max} < 2.4V$

Electrical Characteristics

Over recommended operating supply and temperature ranges unless other specified.

Symbol	Parameter	Conditions	Min	Typ (Note 5)	Max	Units
LVTTL DC SPECIFICATIONS (EN)						
V_{IH}	High Level Input Voltage		2.0		V_{DD}	V
V_{IL}	Low Level Input Voltage		GND		0.8	V
I_{IH}	High Level Input Current	$V_{IN} = V_{DD} = V_{DDMAX}$	-10		+10	μA
I_{IL}	Low Level Input Current	$V_{IN} = V_{SS}, V_{DD} = V_{DDMAX}$	-10		+10	μA
C_{IN1}	Input Capacitance	Any Digital Input Pin to V_{SS}		3.5		pF
V_{CL}	Input Clamp Voltage	$I_{CL} = -18\ mA$	-1.5	-0.8		V
LVDS INPUT DC SPECIFICATIONS (INn\pm)						
V_{TH}	Differential Input High Threshold (Note 6)	$V_{CM} = 0.8V\ to\ 3.4V,$ $V_{DD} = 3.45V$		0	100	mV
V_{TL}	Differential Input Low Threshold (Note 6)	$V_{CM} = 0.8V\ to\ 3.4V,$ $V_{DD} = 3.45V$	-100	0		mV
V_{ID}	Differential Input Voltage	$V_{CM} = 0.8V\ to\ 3.4V, V_{DD} = 3.45V$	100		2400	mV
V_{CMR}	Common Mode Voltage Range	$V_{ID} = 150\ mV, V_{DD} = 3.45V$	0.05		3.40	V
C_{IN2}	Input Capacitance	IN+ or IN- to V_{SS}		3.5		pF
I_{IN}	Input Current	$V_{IN} = 3.45V, V_{DD} = V_{DDMAX}$	-10		+10	μA
		$V_{IN} = 0V, V_{DD} = V_{DDMAX}$	-10		+10	μA

Symbol	Parameter	Conditions	Min	Typ (Note 5)	Max	Units
LVDS OUTPUT DC SPECIFICATIONS (OUT_{n±})						
V _{OD}	Differential Output Voltage (Note 6)	R _L = 100Ω external resistor between OUT+ and OUT-	250	500	600	mV
ΔV _{OD}	Change in V _{OD} between Complementary States		-35		35	mV
V _{OS}	Offset Voltage (Note 7)		1.05	1.18	1.475	V
ΔV _{OS}	Change in V _{OS} between Complementary States		-35		35	mV
I _{OS}	Output Short Circuit Current	OUT+ or OUT- Short to GND		-60	-90	mA
C _{OUT2}	Output Capacitance	OUT+ or OUT- to GND when TRI-STATE		5.5		pF
SUPPLY CURRENT (Static)						
I _{CC}	Total Supply Current	All inputs and outputs enabled and active, terminated with external differential load of 100Ω between OUT+ and OUT-.		117	140	mA
I _{CCZ}	TRI-STATE Supply Current	EN = 0V		2.7	6	mA
SWITCHING CHARACTERISTICS—LVDS OUTPUTS						
t _{LHT}	Differential Low to High Transition Time	Use an alternating 1 and 0 pattern at 200 Mbps, measure between 20% and 80% of V _{OD} . (Note 12)		210	300	ps
t _{HLT}	Differential High to Low Transition Time			210	300	ps
t _{PLHD}	Differential Low to High Propagation Delay	Use an alternating 1 and 0 pattern at 200 Mbps, measure at 50% V _{OD} between input to output.		2.0	3.2	ns
t _{PHLD}	Differential High to Low Propagation Delay			2.0	3.2	ns
t _{SKD1}	Pulse Skew	t _{PLHD} - t _{PHLD} (Note 12)		25	80	ps
t _{SKCC}	Output Channel to Channel Skew	Difference in propagation delay (t _{PLHD} or t _{PHLD}) among all output channels. (Note 12)		50	125	ps
t _{SKP}	Part to Part Skew	Common edge, parts at same temp and V _{CC} (Note 12)			1.1	ns
t _{JIT}	Jitter (Note 8)	RJ - Alternating 1 and 0 at 400 MHz (Note 9)		1.1	1.5	psrms
		DJ - K28.5 Pattern, 800 Mbps (Note 10)		15	35	psp-p
		TJ - PRBS 2 ²³ -1 Pattern, 800 Mbps (Note 11)		30	55	psp-p
t _{ON}	LVDS Output Enable Time	Time from EN to OUT± change from TRI-STATE to active.			300	ns
t _{OFF}	LVDS Output Disable Time	Time from EN to OUT± change from active to TRI-STATE.			12	ns

Note 5: Typical parameters are measured at V_{DD} = 3.3V, T_A = 25°C. They are for reference purposes, and are not production-tested.

Note 6: Differential output voltage V_{OD} is defined as ABS(OUT+ - OUT-). Differential input voltage V_{ID} is defined as ABS(IN+ - IN-).

Note 7: Output offset voltage V_{OS} is defined as the average of the LVDS single-ended output voltages at logic high and logic low states.

Note 8: Jitter is not production tested, but guaranteed through characterization on a sample basis.

Note 9: Random Jitter, or RJ, is measured RMS with a histogram including 1500 histogram window hits. The input voltage = V_{ID} = 500mV, 50% duty cycle at 400 MHz, t_r = t_f = 50ps (20% to 80%).

Note 10: Deterministic Jitter, or DJ, is measured to a histogram mean with a sample size of 350 hits. The input voltage = V_{ID} = 500mV, K28.5 pattern at 800 Mbps, t_r = t_f = 50ps (20% to 80%). The K28.5 pattern is repeating bit streams of (0011111010 1100000101).

Note 11: Total Jitter, or TJ, is measured peak to peak with a histogram including 3500 window hits. Stimulus and fixture Jitter has been subtracted. The input voltage = V_{ID} = 500mV, 2²³-1 PRBS pattern at 800 Mbps, t_r = t_f = 50ps (20% to 80%).

Note 12: Not production tested. Guaranteed by statistical analysis on a sample basis at the time of characterization.

Feature Descriptions

INTERNAL TERMINATIONS

The DS90LV804 has integrated termination resistors on both the input and outputs. The inputs have a 100 Ω resistor across the differential pair, placing the receiver termination as close as possible to the input stage of the device. The LVDS outputs also contain an integrated 100 Ω ohm termination resistor, this resistor is used to reduce the effects of Near End Crosstalk (NEXT) and does not take the place of the 100 ohm termination at the inputs to the receiving device. The integrated terminations improve signal integrity and decrease the external component count resulting in space savings.

OUTPUT CHARACTERISTICS

The output characteristics of the DS90LV804 have been optimized for point-to-point backplane and cable applications, and are not intended for multipoint or multidrop signaling.

TRI-STATE MODE

The EN input activates a hardware TRI-STATE mode. When the TRI-STATE mode is active (EN=L), all input and output

buffers and internal bias circuitry are powered off and disabled. Outputs are tri-stated in TRI-STATE mode. When exiting TRI-STATE mode, there is a delay associated with turning on bandgap references and input/output buffer circuits as indicated in the LVDS Output Switching Characteristics

INPUT FAILSAFE BIASING

External pull up and pull down resistors may be used to provide enough of an offset to enable an input failsafe under open-circuit conditions. This configuration ties the positive LVDS input pin to V_{DD} thru a pull up resistor and the negative LVDS input pin is tied to GND by a pull down resistor. The pull up and pull down resistors should be in the 5k Ω to 15k Ω range to minimize loading and waveform distortion to the driver. The common-mode bias point ideally should be set to approximately 1.2V (less than 1.75V) to be compatible with the internal circuitry. Please refer to application note AN-1194 "Failsafe Biasing of LVDS Interfaces" for more information.

INPUT INTERFACING

The DS90LV804 accepts differential signals and allow simple AC or DC coupling. With a wide common mode range, the DS90LV804 can be DC-coupled with all common differential

drivers (i.e. LVPECL, LVDS, CML). The following three figures illustrate typical DC-coupled interface to common differential drivers. Note that the DS90LV804 inputs are internally terminated with a 100Ω resistor.

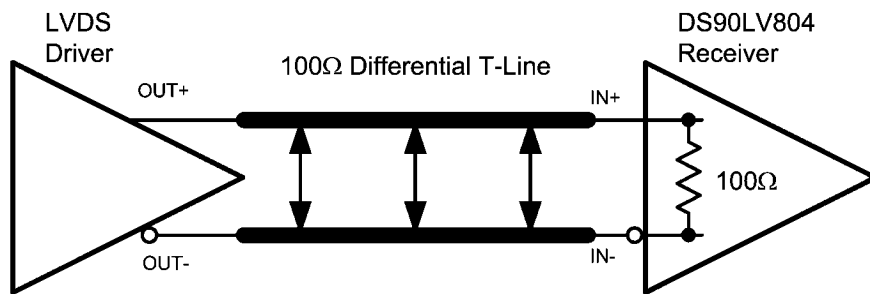

Typical LVDS Driver DC-Coupled Interface to DS90LV804 Input

20156731

CML3.3V or CML2.5V Driver

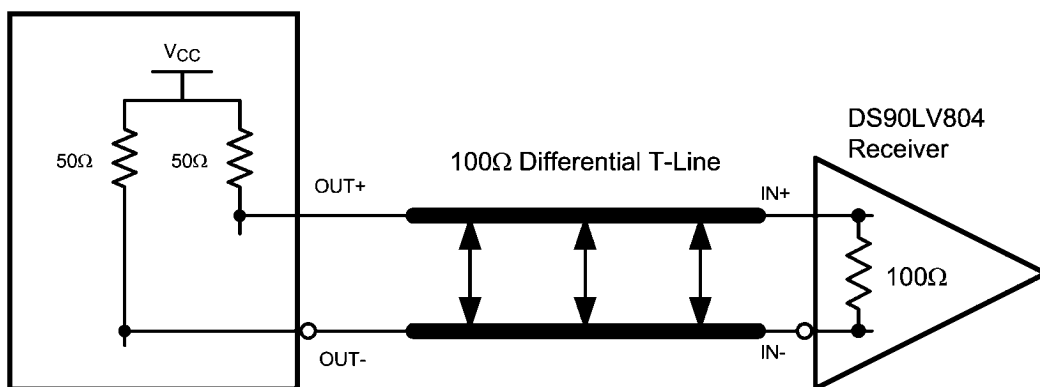

Typical CML Driver DC-Coupled Interface to DS90LV804 Input

20156732

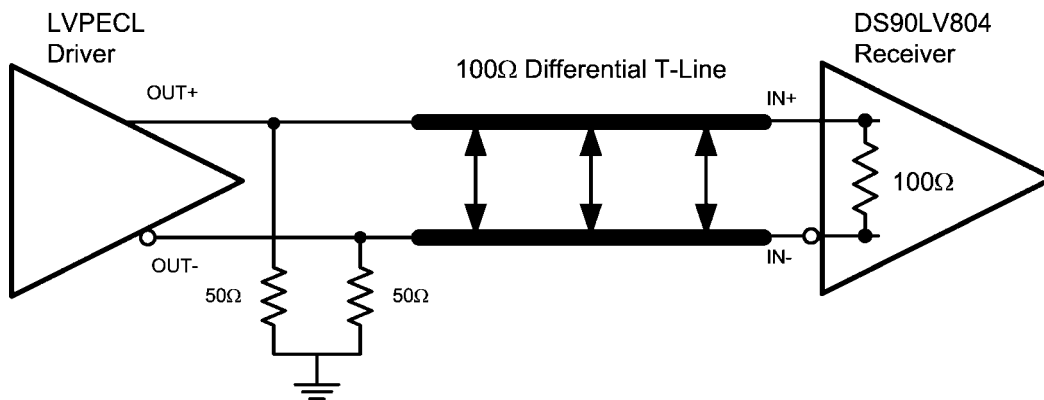

Typical LVPECL Driver DC-Coupled Interface to DS90LV804 Input

20156733

OUTPUT INTERFACING

The DS90LV804 outputs signals that are compliant to the LVDS standard. Their outputs can be DC-coupled to most common differential receivers. The following figure illustrates typical DC-coupled interface to common differential receivers

and assumes that the receivers have high impedance inputs. While most differential receivers have a common mode input range that can accommodate LVDS compliant signals, it is recommended to check respective receiver's data sheet prior to implementing the suggested interface implementation.

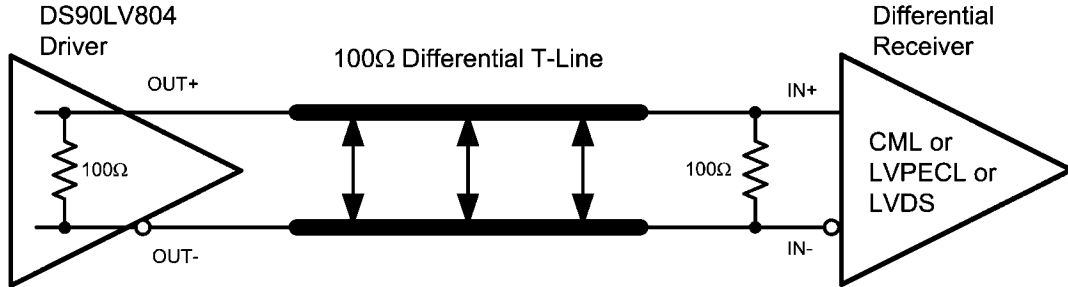

Typical DS90LV804 Output DC-Coupled Interface to an LVDS, CML or LVPECL Receiver 20156734

Typical Performance Characteristics

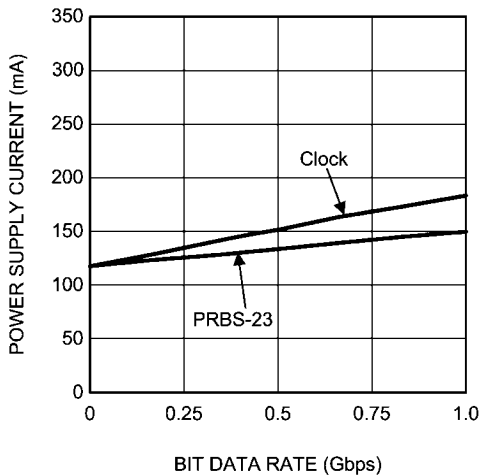

Dynamic power supply current was measured while running a clock or PRBS 2²³-1 pattern with all 4 channels active. $V_{CC} = 3.3V$, $T_A = +25^\circ C$, $V_{ID} = 0.5V$, $V_{CM} = 1.2V$

Power Supply Current vs. Bit Data Rate

Packaging Information

The Leadless Leadframe Package (LLP) is a leadframe based chip scale package (CSP) that may enhance chip speed, reduce thermal impedance, and reduce the printed circuit board area required for mounting. The small size and very low profile make this package ideal for high density PCBs used in small-scale electronic applications such as cellular phones, pagers, and handheld PDAs. The LLP package is offered in the no Pullback configuration. In the no Pullback configuration the standard solder pads extend and terminate at the edge of the package. This feature offers a visible solder fillet after board mounting.

The LLP has the following advantages:

- Low thermal resistance
- Reduced electrical parasitics
- Improved board space efficiency
- Reduced package height
- Reduced package mass

For more details about LLP packaging technology, refer to applications note AN-1187, "Leadless Leadframe Package"

Physical Dimensions inches (millimeters) unless otherwise noted

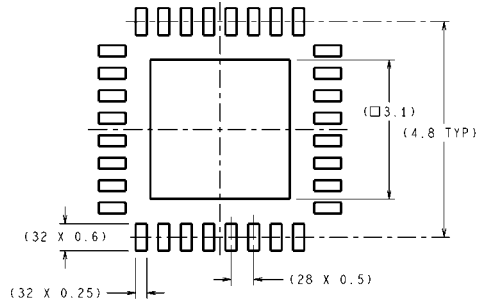

DIMENSIONS ARE IN MILLIMETERS
DIMENSIONS IN () FOR REFERENCE ONLY

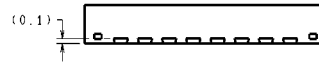

RECOMMENDED LAND PATTERN

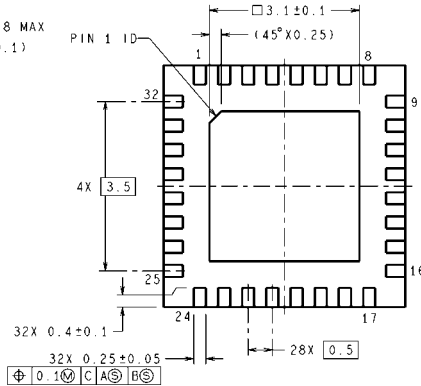
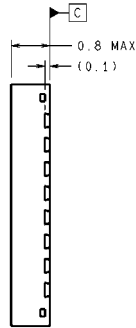
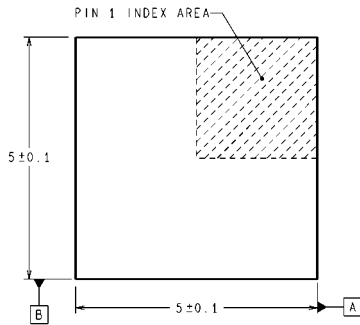

SQA32A (Rev A)

32-LLP, Plastic, Quad
Order Number DS90LV804TSQ (1000 piece Tape and Reel)
DS90LV804TSQX (4500 piece Tape and Reel)
NS Package Number SQA32A

Notes

For more National Semiconductor product information and proven design tools, visit the following Web sites at:

Products		Design Support	
Amplifiers	www.national.com/amplifiers	WEBENCH	www.national.com/webench
Audio	www.national.com/audio	Analog University	www.national.com/AU
Clock Conditioners	www.national.com/timing	App Notes	www.national.com/appnotes
Data Converters	www.national.com/adc	Distributors	www.national.com/contacts
Displays	www.national.com/displays	Green Compliance	www.national.com/quality/green
Ethernet	www.national.com/ethernet	Packaging	www.national.com/packaging
Interface	www.national.com/interface	Quality and Reliability	www.national.com/quality
LVDS	www.national.com/lvds	Reference Designs	www.national.com/refdesigns
Power Management	www.national.com/power	Feedback	www.national.com/feedback
Switching Regulators	www.national.com/switchers		
LDOs	www.national.com/lido		
LED Lighting	www.national.com/led		
PowerWise	www.national.com/powerwise		
Serial Digital Interface (SDI)	www.national.com/sdi		
Temperature Sensors	www.national.com/tempsensors		
Wireless (PLL/VCO)	www.national.com/wireless		

THE CONTENTS OF THIS DOCUMENT ARE PROVIDED IN CONNECTION WITH NATIONAL SEMICONDUCTOR CORPORATION ("NATIONAL") PRODUCTS. NATIONAL MAKES NO REPRESENTATIONS OR WARRANTIES WITH RESPECT TO THE ACCURACY OR COMPLETENESS OF THE CONTENTS OF THIS PUBLICATION AND RESERVES THE RIGHT TO MAKE CHANGES TO SPECIFICATIONS AND PRODUCT DESCRIPTIONS AT ANY TIME WITHOUT NOTICE. NO LICENSE, WHETHER EXPRESS, IMPLIED, ARISING BY ESTOPPEL OR OTHERWISE, TO ANY INTELLECTUAL PROPERTY RIGHTS IS GRANTED BY THIS DOCUMENT.

TESTING AND OTHER QUALITY CONTROLS ARE USED TO THE EXTENT NATIONAL DEEMS NECESSARY TO SUPPORT NATIONAL'S PRODUCT WARRANTY. EXCEPT WHERE MANDATED BY GOVERNMENT REQUIREMENTS, TESTING OF ALL PARAMETERS OF EACH PRODUCT IS NOT NECESSARILY PERFORMED. NATIONAL ASSUMES NO LIABILITY FOR APPLICATIONS ASSISTANCE OR BUYER PRODUCT DESIGN. BUYERS ARE RESPONSIBLE FOR THEIR PRODUCTS AND APPLICATIONS USING NATIONAL COMPONENTS. PRIOR TO USING OR DISTRIBUTING ANY PRODUCTS THAT INCLUDE NATIONAL COMPONENTS, BUYERS SHOULD PROVIDE ADEQUATE DESIGN, TESTING AND OPERATING SAFEGUARDS.

EXCEPT AS PROVIDED IN NATIONAL'S TERMS AND CONDITIONS OF SALE FOR SUCH PRODUCTS, NATIONAL ASSUMES NO LIABILITY WHATSOEVER, AND NATIONAL DISCLAIMS ANY EXPRESS OR IMPLIED WARRANTY RELATING TO THE SALE AND/OR USE OF NATIONAL PRODUCTS INCLUDING LIABILITY OR WARRANTIES RELATING TO FITNESS FOR A PARTICULAR PURPOSE, MERCHANTABILITY, OR INFRINGEMENT OF ANY PATENT, COPYRIGHT OR OTHER INTELLECTUAL PROPERTY RIGHT.

LIFE SUPPORT POLICY

NATIONAL'S PRODUCTS ARE NOT AUTHORIZED FOR USE AS CRITICAL COMPONENTS IN LIFE SUPPORT DEVICES OR SYSTEMS WITHOUT THE EXPRESS PRIOR WRITTEN APPROVAL OF THE CHIEF EXECUTIVE OFFICER AND GENERAL COUNSEL OF NATIONAL SEMICONDUCTOR CORPORATION. As used herein:

Life support devices or systems are devices which (a) are intended for surgical implant into the body, or (b) support or sustain life and whose failure to perform when properly used in accordance with instructions for use provided in the labeling can be reasonably expected to result in a significant injury to the user. A critical component is any component in a life support device or system whose failure to perform can be reasonably expected to cause the failure of the life support device or system or to affect its safety or effectiveness.

National Semiconductor and the National Semiconductor logo are registered trademarks of National Semiconductor Corporation. All other brand or product names may be trademarks or registered trademarks of their respective holders.

Copyright© 2008 National Semiconductor Corporation

For the most current product information visit us at www.national.com



**National Semiconductor
Americas Technical
Support Center**
Email: support@nsc.com
Tel: 1-800-272-9959

**National Semiconductor Europe
Technical Support Center**
Email: europe.support@nsc.com
German Tel: +49 (0) 180 5010 771
English Tel: +44 (0) 870 850 4288

**National Semiconductor Asia
Pacific Technical Support Center**
Email: ap.support@nsc.com

**National Semiconductor Japan
Technical Support Center**
Email: jpn.feedback@nsc.com