

LME49743

Quad High Performance, High Fidelity Audio Operational Amplifier

General Description

The LME49743 is a low distortion, low noise, high slew rate operational amplifier optimized and fully specified for high performance, high fidelity applications. The LME49743 audio operational amplifier delivers superior audio signal amplification for outstanding audio performance. The LME49743 combines low voltage noise density ($3.5\text{nV}/\sqrt{\text{Hz}}$) and THD+N (0.0001%) to easily satisfy demanding audio applications. To ensure that the most challenging loads are driven without compromise, the LME49743 has a slew rate of $\pm 12\text{V}/\mu\text{s}$ and an output current capability of $\pm 21\text{mA}$.

The LME49743's outstanding CMRR(106dB), PSRR(98dB), and V_{OS} ($\pm 0.15\text{mV}$) give the amplifier excellent operational amplifier DC performance.

The LME49743 has a wide supply range of $\pm 4.0\text{V}$ to $\pm 17\text{V}$. Over this supply range the LME49743's input circuitry maintains excellent common-mode, power supply rejection, and low input bias current. The LME49743 is unity gain stable.

The LME49743 is available in 14-lead TSSOP.

Key Specifications

■ Power Supply Voltage Range	$\pm 4.0\text{V}$ to $\pm 17\text{V}$
■ THD+N ($A_V = 1$, $V_{OUT} = 3V_{RMS}$, $f_{IN} = 1\text{kHz}$)	
$R_L = 2\text{k}\Omega$	0.0001% (typ)
$R_L = 600\Omega$	0.0001% (typ)
■ Input Noise Density	$3.5\text{nV}/\sqrt{\text{Hz}}$ (typ)
■ Slew Rate	$\pm 12\text{V}/\mu\text{s}$ (typ)
■ Gain Bandwidth Product	30MHz (typ)
■ Open Loop Gain ($R_L = 600\Omega$)	110dB (typ)
■ Input Bias Current	190nA (typ)
■ Input Offset Voltage	$\pm 0.15\text{mV}$ (typ)

Features

- Easily drives 600Ω loads
- Optimized for superior audio signal fidelity
- Output short circuit protection
- 98dB (typ) PSRR and 106dB (typ) CMRR
- TSSOP package

Applications

- Audio amplifiers and preamplifiers
- Professional Audio
- Equalization and crossover networks
- Line drivers and receivers
- Active filters

Connection Diagram

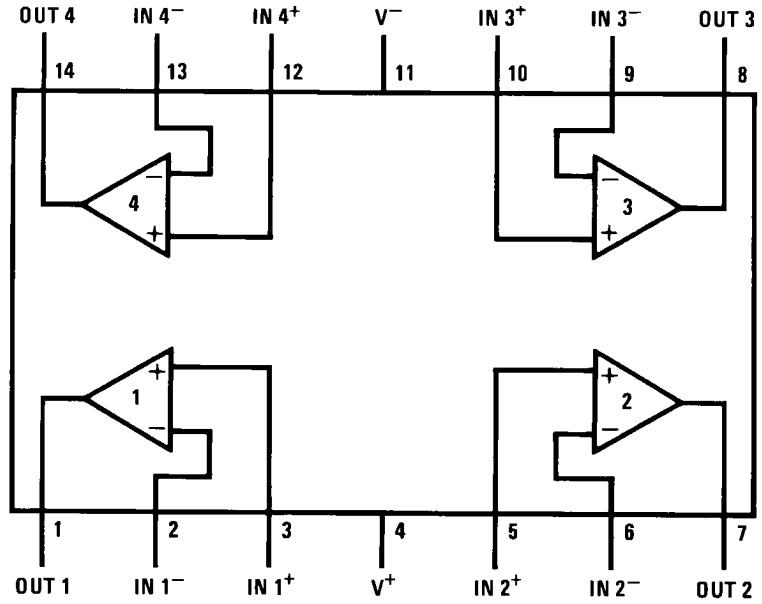

30048101

Order Number LME49743MT
See NS Package Number — MTC14

Absolute Maximum Ratings (Notes 1, 2)

If Military/Aerospace specified devices are required, please contact the National Semiconductor Sales Office/ Distributors for availability and specifications.

Power Supply Voltage ($V_S = V^+ - V^-$)	36V
Storage Temperature	-65°C to 150°C
Input Voltage	(V-) - 0.7V to (V+) + 0.7V
Output Short Circuit (Note 3)	Continuous

Power Dissipation	Internally Limited
ESD Susceptibility (Note 4)	750V
ESD Susceptibility (Note 5)	175V
Junction Temperature	150°C
Thermal Resistance	
θ_{JA} (MT)	140°C/W
Temperature Range	
$T_{MIN} \leq T_A \leq T_{MAX}$	-40°C $\leq T_A \leq$ 85°C
Supply Voltage Range	$\pm 4.0V \leq V_S \leq \pm 17V$

Electrical Characteristics (Notes 1, 2) The following specifications apply for $V_S = \pm 15V$, $R_L = 2k\Omega$, $f_{IN} = 1kHz$, and $T_A = 25C$, unless otherwise specified.

Symbol	Parameter	Conditions	LME49743		Units (Limits)
			Typical	Limit	
			(Note 6)	(Notes 7, 8)	
THD+N	Total Harmonic Distortion + Noise	$A_V = 1$, $V_{OUT} = 3V_{RMS}$ $R_L = 2k\Omega$ $R_L = 600\Omega$	0.0001 0.0001	0.0002	% (max)
IMD	Intermodulation Distortion	$A_V = 1$, $V_{OUT} = 3V_{RMS}$ Two-tone, 60Hz & 7kHz 4:1	0.0005		% (max)
GBWP	Gain Bandwidth Product		30	25	MHz (min)
SR	Slew Rate		12	9.5	V/ μ s (min)
FPBW	Full Power Bandwidth	$V_{OUT} = 1V_{P-P}$, -3dB referenced to output magnitude at $f = 1kHz$	10		MHz
t_s	Settling time	$A_V = 1$, 10V step, $C_L = 100pF$ 0.1% error range	1.2		μ s
e_n	Equivalent Input Noise Voltage	$f_{BW} = 20Hz$ to 20kHz	0.48	0.65	μV_{RMS}
	Equivalent Input Noise Density	$f = 1kHz$ $f = 10Hz$	3.5 6.4	4.5	nV/ \sqrt{Hz} (max) nV/ \sqrt{Hz}
i_n	Current Noise Density	$f = 1kHz$ $f = 10Hz$	1.6		pA/ \sqrt{Hz}
			3.1		pA/ \sqrt{Hz}
V_{OS}	Offset Voltage		± 0.15	± 1.0	mV (max)
$\Delta V_{OS}/\Delta Temp$	Average Input Offset Voltage Drift vs Temperature	$40^\circ C \leq T_A \leq 85^\circ C$	0.05		$\mu V/^\circ C$
PSRR	Average Input Offset Voltage Shift vs Power Supply Voltage	$\Delta V_S = 20V$ (Note 9)	98	94	dB (min)
ISO_{CH-CH}	Channel-to-Channel Isolation	$f_{IN} = 1kHz$ $f_{IN} = 20kHz$	118		dB
			112		dB
I_B	Input Bias Current	$V_{CM} = 0V$	190	250	nA (max)
$\Delta I_{OS}/\Delta Temp$	Input Bias Current Drift vs Temperature	$-40^\circ C \leq T_A \leq 85^\circ C$	0.05		nA/ $^\circ C$
I_{OS}	Input Offset Current	$V_{CM} = 0V$	7	40	nA (max)
V_{IN-CM}	Common-Mode Input Voltage Range		± 13.2	(V+)-2.0 (V-)+2.0	V (min) V (min)
CMRR	Common-Mode Rejection	$-10V < V_{CM} < 10V$	106	98	dB (min)
Z_{IN}	Differential Input Impedance		30		k Ω
	Common Mode Input Impedance	$-10V < V_{CM} < 10V$	1000		M Ω
A_{VOL}	Open Loop Voltage Gain	$-10V < V_{OUT} < 10V$, $R_L = 600\Omega$	110		dB (min)
		$-10V < V_{OUT} < 10V$, $R_L = 2k\Omega$	110		dB (min)
		$-10V < V_{OUT} < 10V$, $R_L = 10k\Omega$	110	100	dB (min)

Symbol	Parameter	Conditions	LME49743		Units (Limits)
			Typical	Limit	
			(Note 6)	(Notes 7, 8)	
V _{OUTMAX}	Maximum Output Voltage Swing	R _L = 600Ω	±12.4	±12.0	V (min)
		R _L = 2kΩ	±13.0		V (min)
		R _L = 10kΩ	±13.0		V (min)
I _{OUT}	Output Current	R _L = 600Ω, V _S = ±17V	±21	±20	mA (min)
I _{OUT-CC}	Short Circuit Current		+30 -38		mA mA
R _{OUT}	Output Impedance	f _{IN} = 10kHz Closed-Loop	0.01		Ω
		Open-Loop	13		Ω
C _{LOAD}	Capacitive Load Drive Overshoot	100pF	16		%
I _S	Total Quiescent Current	I _{OUT} = 0mA	10	14	mA (max)

Note 1: *Absolute Maximum Ratings* indicate limits beyond which damage to the device may occur.

Note 2: *Operating Ratings* indicate conditions for which the device is functional, but do not guarantee specific performance limits. For guaranteed specifications and test conditions, see the Electrical Characteristics. The guaranteed specifications apply only for the test conditions listed. Some performance characteristics may degrade when the device is not operated under the listed test conditions.

Note 3: Amplifier output connected to GND, any number of amplifiers within a package.

Note 4: Human body model, 100pF discharged through a 1.5kΩ resistor.

Note 5: Machine Model ESD test is covered by specification EIAJ IC-121-1981. A 200pF cap is charged to the specified voltage and then discharged directly into the IC with no external series resistor (resistance of discharge path must be under 50Ω).

Note 6: Typical specifications are specified at +25°C and represent the most likely parametric norm.

Note 7: Tested limits are guaranteed to National's AOQL (Average Outgoing Quality Level).

Note 8: Datasheet min/max specification limits are guaranteed by design, test, or statistical analysis.

Note 9: PSRR is measured as follows: V_{OS} is measured at two supply voltages, ±5V and ±15V. PSRR = |20log(ΔV_{OS}/ΔV_S)|.

Typical Performance Characteristics

THD+N vs Output Voltage
 $V_S = \pm 15V, R_L = 2k\Omega, f = 1kHz$
 30kHz BW

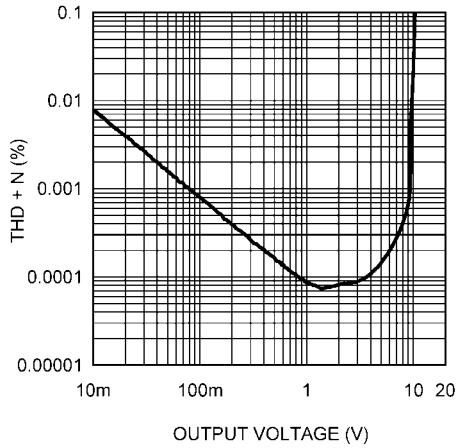

300481b6

THD+N vs Output Voltage
 $V_S = \pm 15V, R_L = 10k\Omega, f = 1kHz$
 30kHz BW

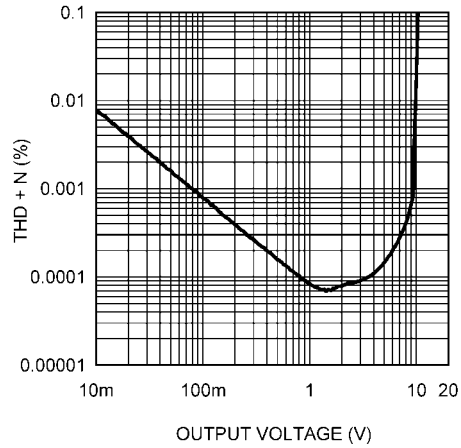

300481b7

THD+N vs Output Voltage
 $V_S = \pm 15V, R_L = 600\Omega, f = 1kHz$
 30kHz BW

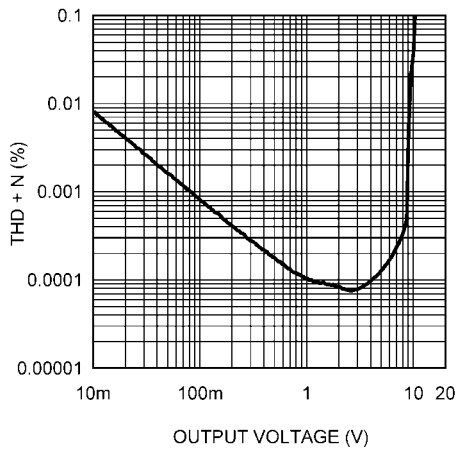

300481b8

THD+N vs Frequency
 $V_S = \pm 15V, V_{OUT} = 3V_{RMS}, R_L = 2k\Omega$
 80kHz BW

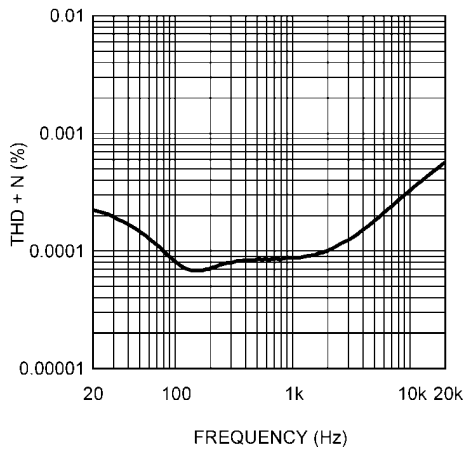

300481b0

THD+N vs Frequency
 $V_S = \pm 15V, V_{OUT} = 3V_{RMS}, R_L = 10k\Omega$
 80kHz BW

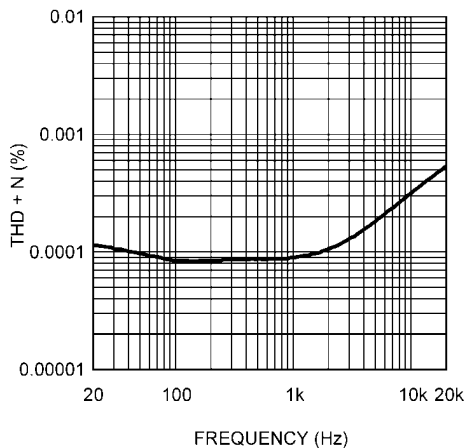

300481b1

THD+N vs Frequency
 $V_S = \pm 15V, V_{OUT} = 3V_{RMS}, R_L = 600\Omega$
 80kHz BW

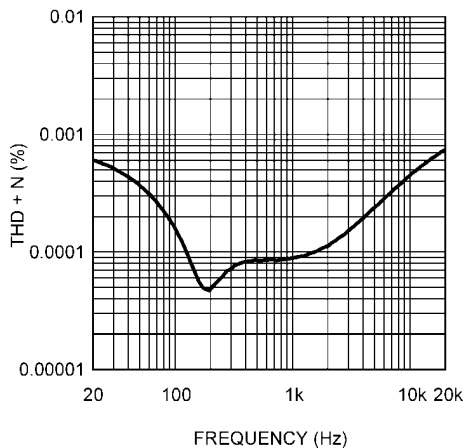

300481b2

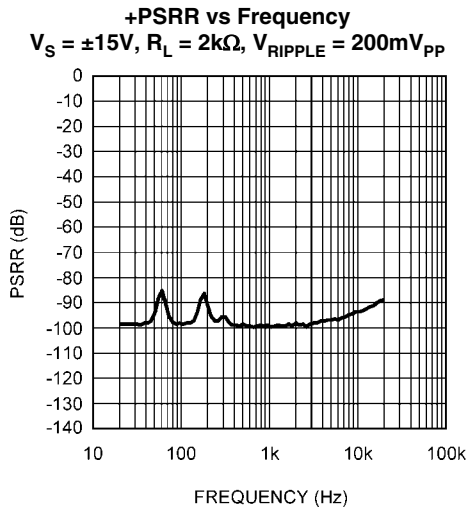

300481a1

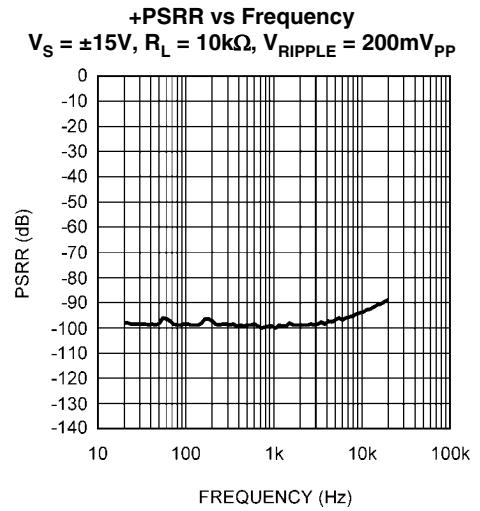

300481a2

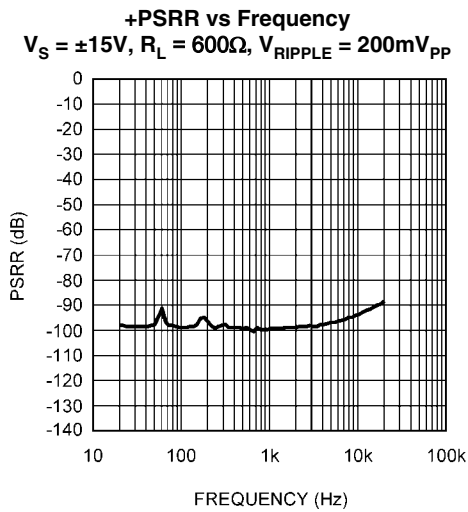

300481a3

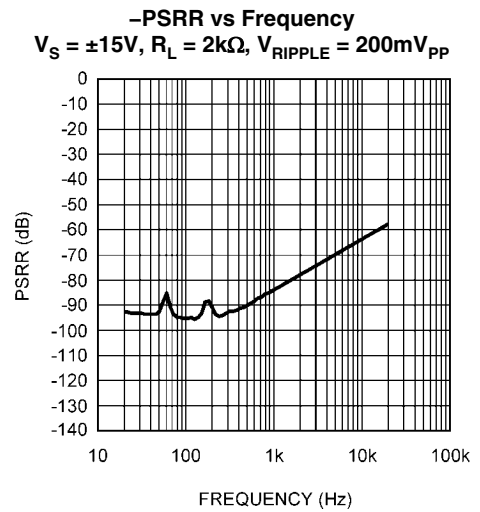

300481a7

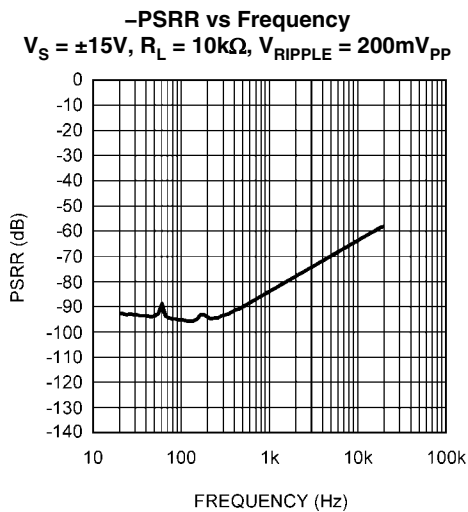

300481a8

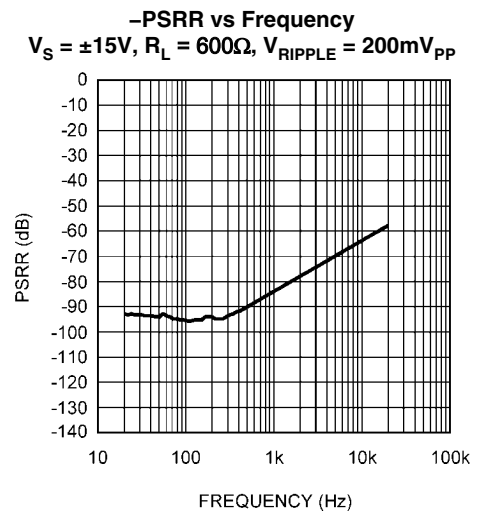

300481a9

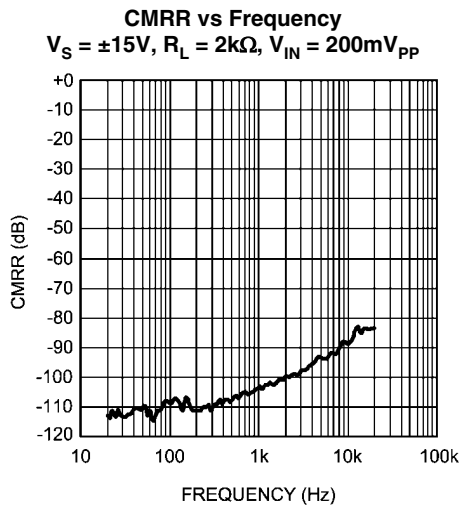

30048189

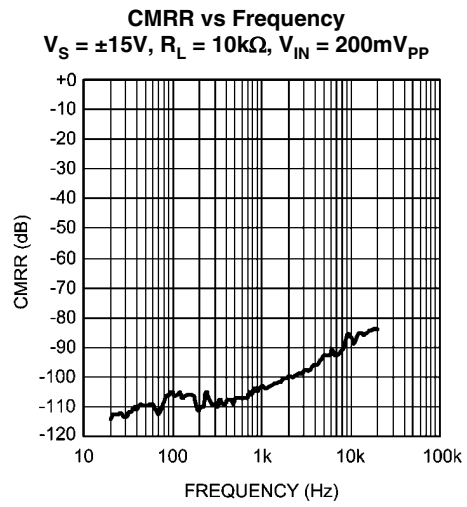

30048190

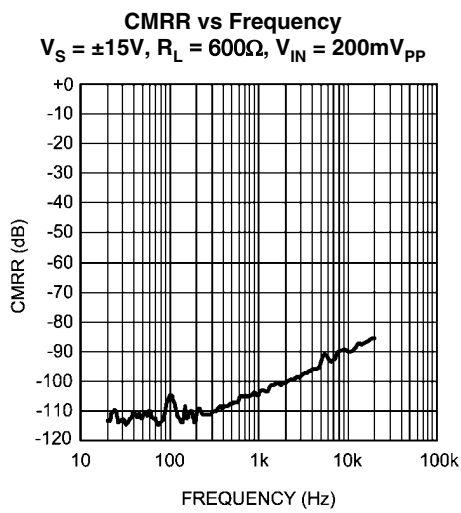

30048191

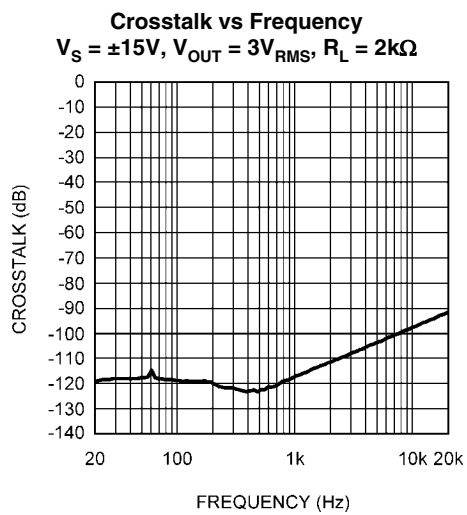

300481b9

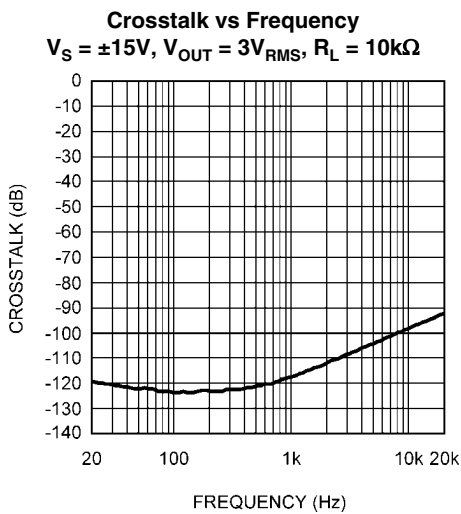

300481c0

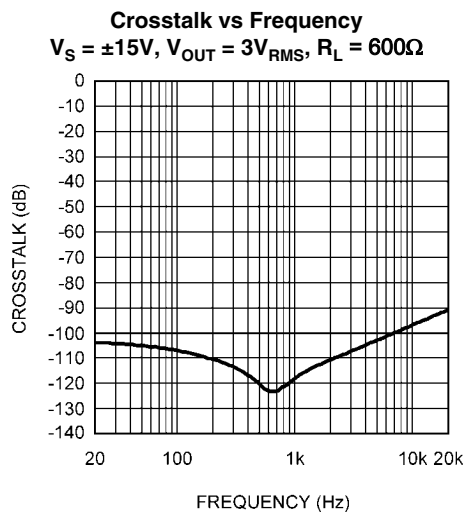

300481c1

IMD vs Output Voltage
 $V_S = \pm 5V, R_L = 2k\Omega$
 7kHz/60Hz 4:1 SMPTE

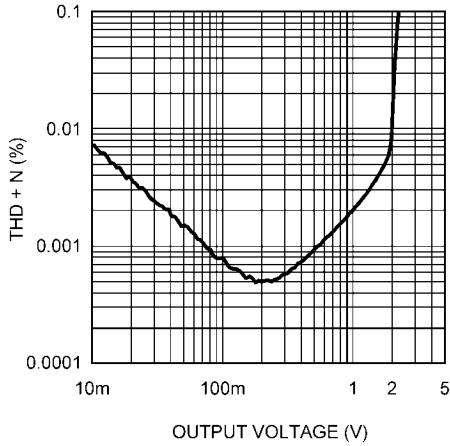

30048195

IMD vs Output Voltage
 $V_S = \pm 5V, R_L = 10k\Omega$
 7kHz/60Hz 4:1 SMPTE

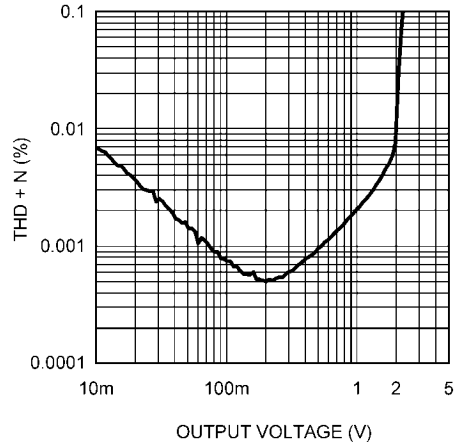

30048196

IMD vs Output Voltage
 $V_S = \pm 5V, R_L = 600\Omega$
 7kHz/60Hz 4:1 SMPTE

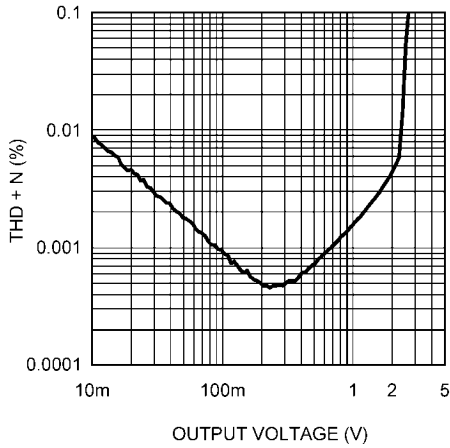

30048197

Output Voltage vs Supply Voltage
 $R_L = 2k\Omega, THD+N = 0.1\%$

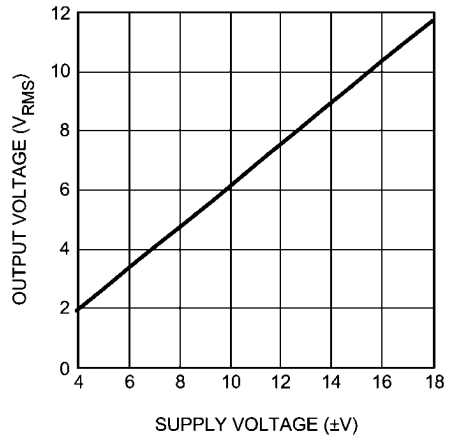

30048163

Output Voltage vs Supply Voltage
 $R_L = 10k\Omega, THD+N = 0.1\%$

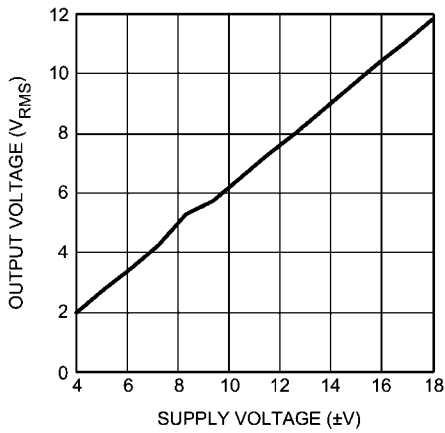

30048164

Output Voltage vs Supply Voltage
 $R_L = 600\Omega, THD+N = 0.1\%$

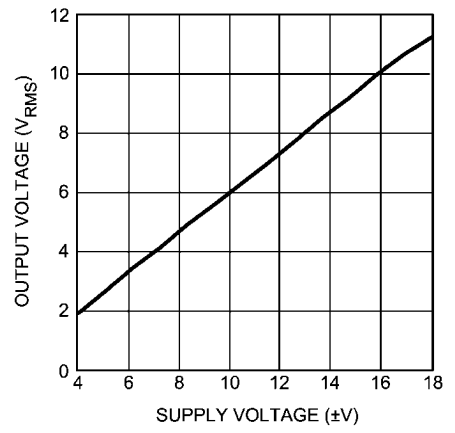

30048165

Supply Current vs Supply Voltage

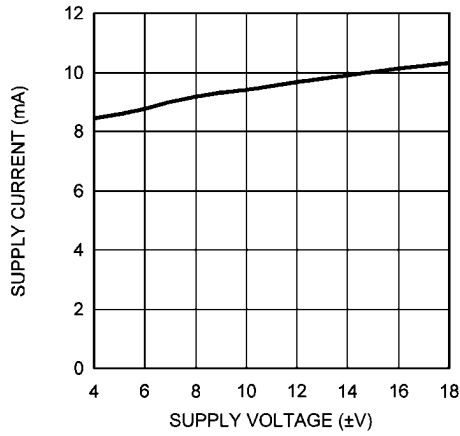

300481c4

Scope Photo Small Signal

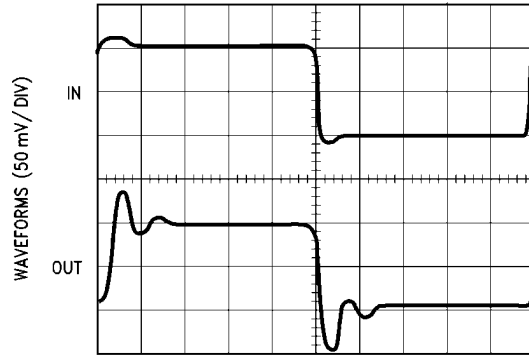

TIME (0.1 μ s / DIV)

30048185

Scope Photo Large Signal, Non-Inverting

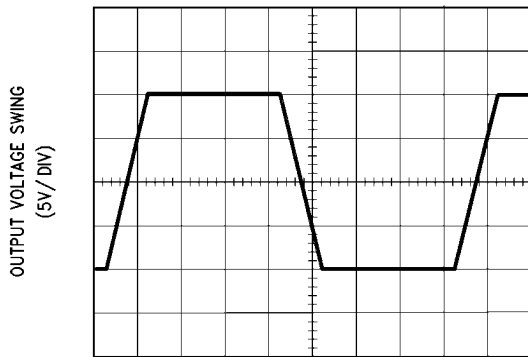

TIME (1 μ s / DIV)

30048186

Scope Photo Large Signal, Inverting

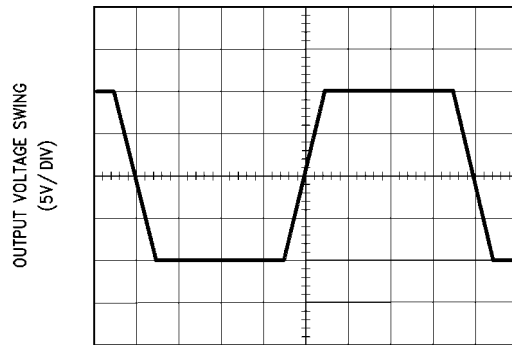

TIME (1 μ s / DIV)

30048187

Equivalent Input Noise vs Frequency

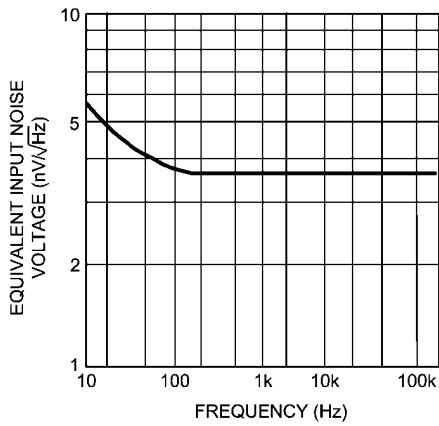

30048188

Power Bandwidth

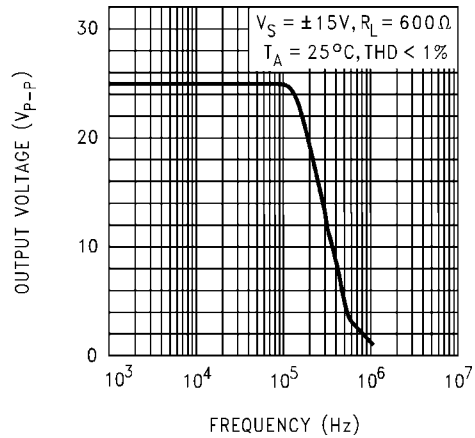

30048192

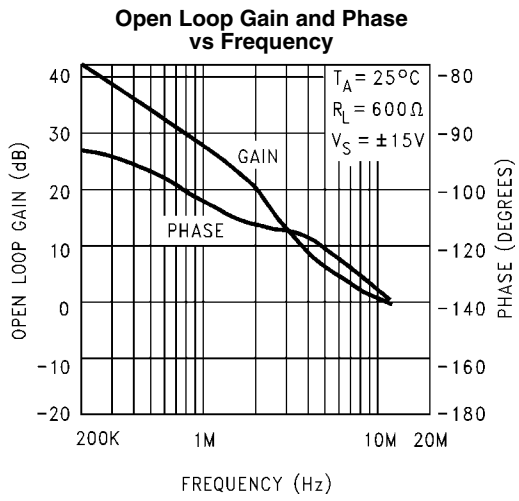

30048193

Application Information

DISTORTION MEASUREMENTS

The vanishingly low residual distortion produced by LME49743 is below the capabilities of all commercially available equipment. This makes distortion measurements just slightly more difficult than simply connecting a distortion meter to the amplifier's inputs and outputs. The solution, however, is quite simple: an additional resistor. Adding this resistor extends the resolution of the distortion measurement equipment.

The LME49743's low residual distortion is an input referred internal error. As shown in Figure 1, adding the 10Ω resistor connected between the amplifier's inverting and non-inverting

inputs changes the amplifier's noise gain. The result is that the error signal (distortion) is amplified by a factor of 101. Although the amplifier's closed-loop gain is unaltered, the feedback available to correct distortion errors is reduced by 101, which means that measurement resolution increases by 101. To ensure minimum effects on distortion measurements, keep the value of R1 low as shown in Figure 1.

This technique is verified by duplicating the measurements with high closed loop gain and/or making the measurements at high frequencies. Doing so produces distortion components that are within the measurement equipment's capabilities. This datasheet's THD+N and IMD values were generated using the above described circuit connected to an Audio Precision System Two Cascade.

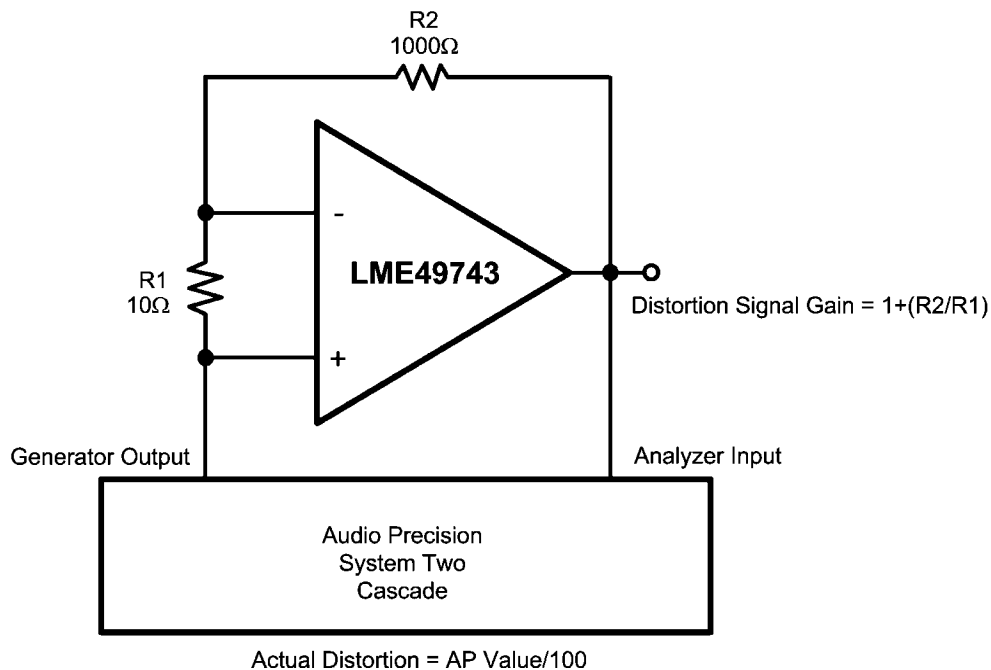

30048122

FIGURE 1. THD+N and IMD Distortion Test Circuit

Application Hints

The LME49743 is a high speed op amp with excellent phase margin and stability. Capacitive loads up to 100pF will cause little change in the phase characteristics of the amplifiers and are therefore allowable.

Capacitive loads greater than 100pF must be isolated from the output. The most straightforward way to do this is to put a resistor in series with the output. This resistor will also prevent excess power dissipation if the output is accidentally shorted.

Noise Measurement Circuit

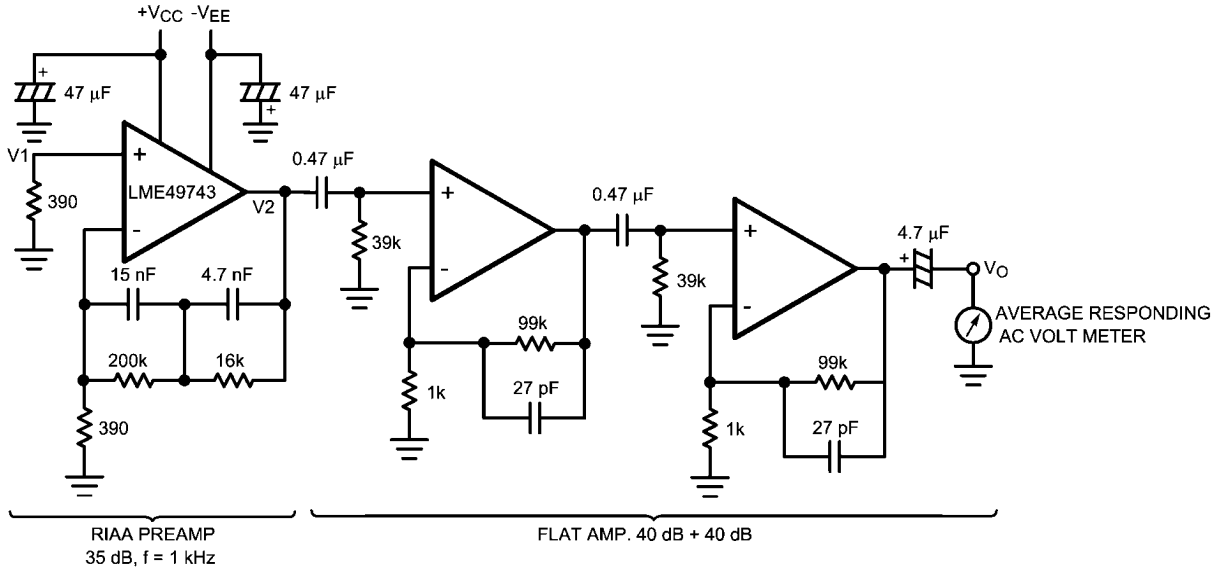

Complete shielding is required to prevent induced pick up from external sources. Always check with oscilloscope for power line noise.

30048121

Total Gain: 115 dB at f = 1 kHz
Input Referred Noise Voltage: $e_n = V_o/560,000$ (V)

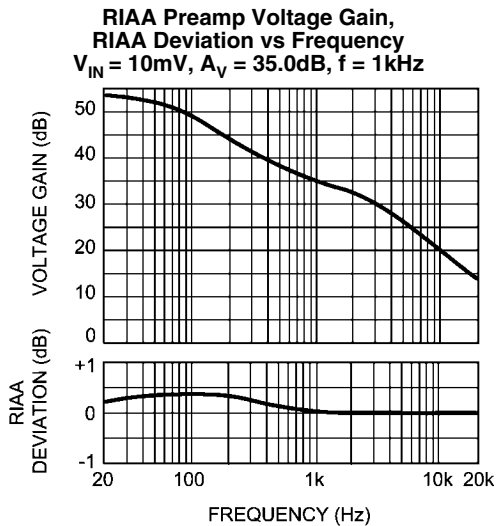

30048128

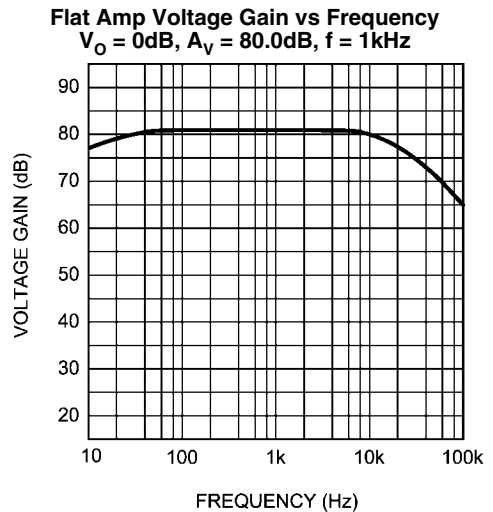

30048129

Typical Applications

State Variable Filter

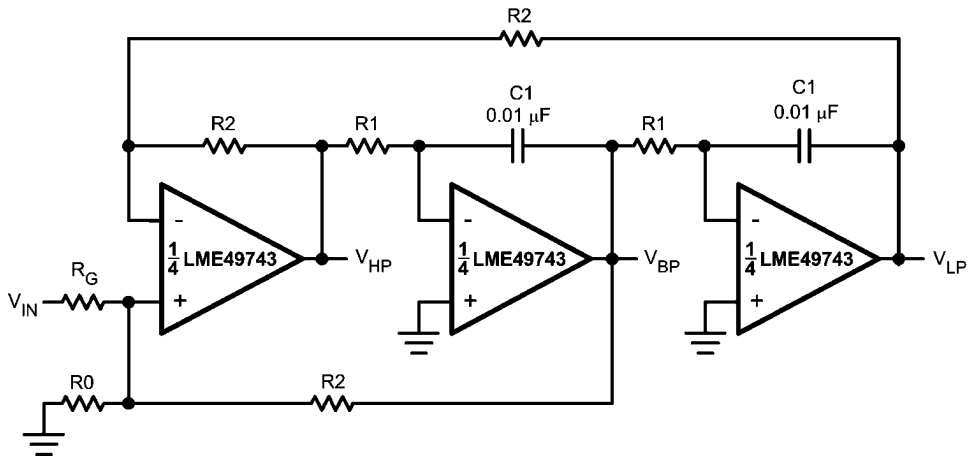

30048137

$$f_0 = \frac{1}{2\pi C_1 R_1}, Q = \frac{1}{2} \left(1 + \frac{R_2}{R_0} + \frac{R_2}{R_G} \right), A_{BP} = Q A_{LP} = Q A_{LH} = \frac{R_2}{R_G}$$

AC/DC Converter

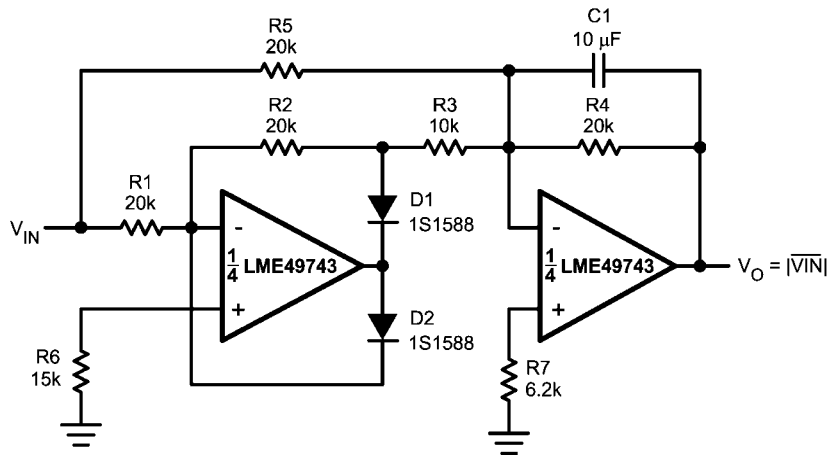

30048138

2 Channel Panning Circuit (Pan Pot)

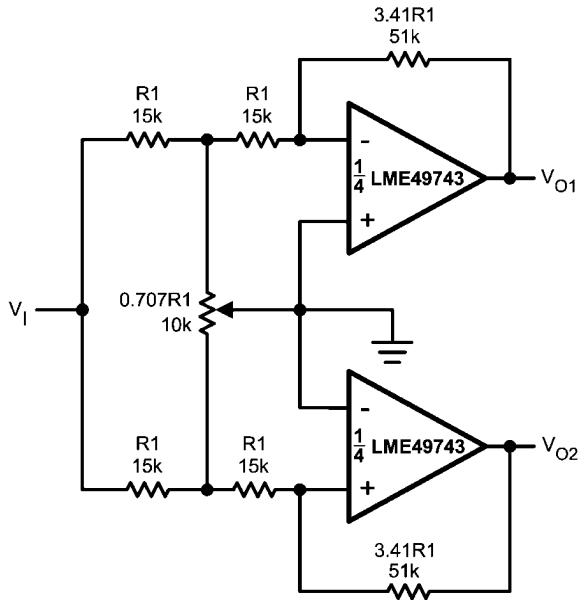

30048139

Line Driver

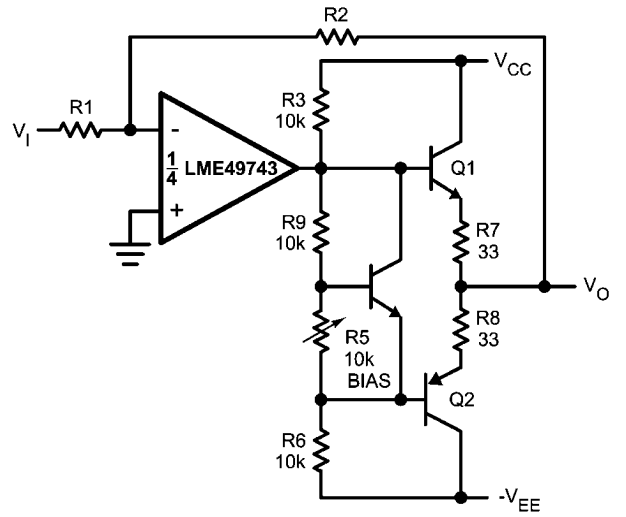

30048140

Tone Control

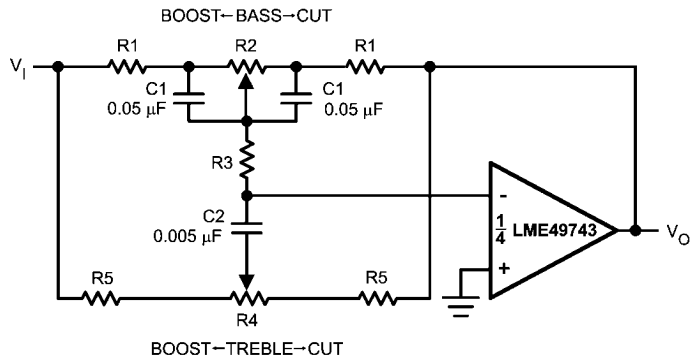

30048141

$$f_L = \frac{1}{2\pi R_2 C_1}, f_{LB} = \frac{1}{2\pi R_1 C_1}$$

$$f_H = \frac{1}{2\pi R_5 C_2}, f_{HB} = \frac{1}{2\pi(R_1 + R_5 + 2R_3)C_2}$$

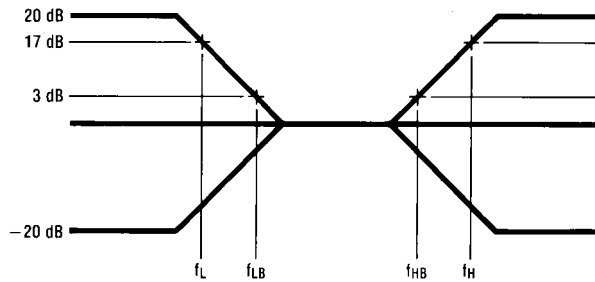

30048142

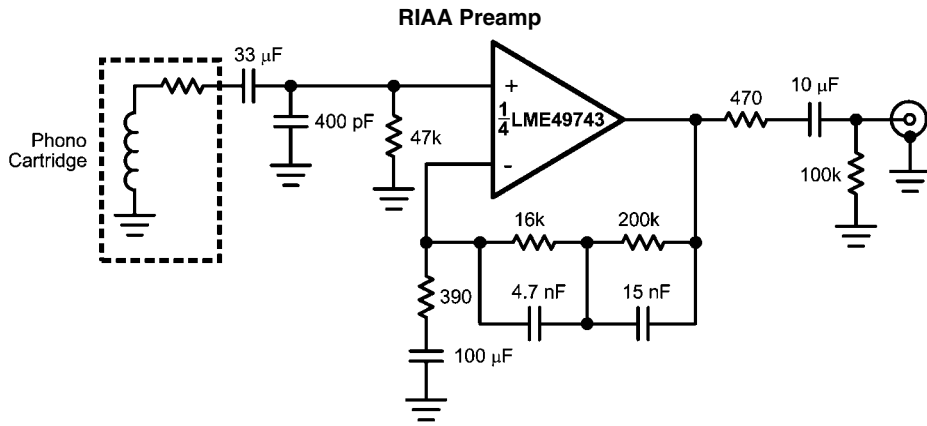

30048103

$A_v = 35 \text{ dB}$
 $E_n = 0.33 \text{ } \mu\text{V}$
 $S/N = 90 \text{ dB}$
 $f = 1 \text{ kHz}$
 A Weighted
 A Weighted, $V_{IN} = 10 \text{ mV}$
 @ $f = 1 \text{ kHz}$

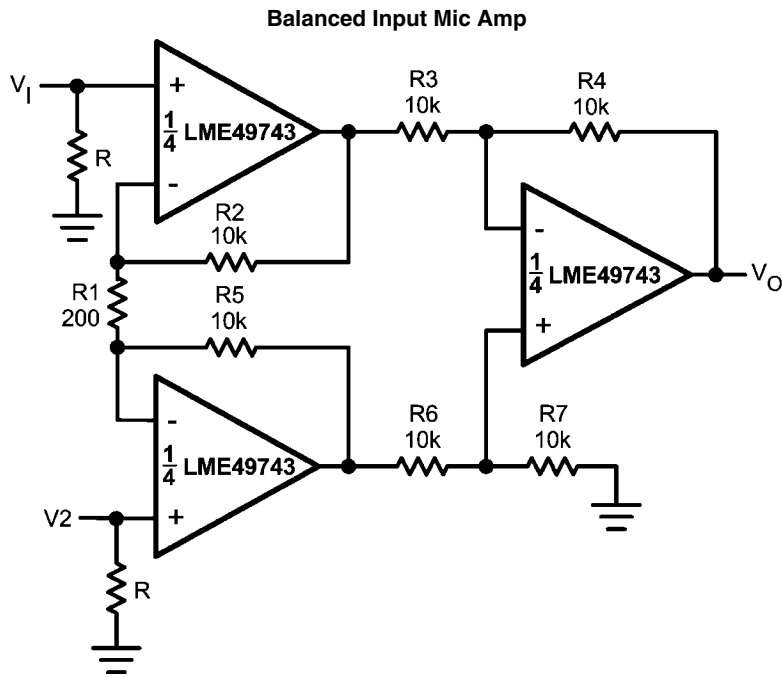

30048143

If $R_2 = R_5, R_3 = R_6, R_4 = R_7$

$$V_0 = \left(1 + \frac{2R_2}{R_1} \right) \frac{R_4}{R_3} (V_2 - V_1)$$

Illustration is:
 $V_0 = 101(V_2 - V_1)$

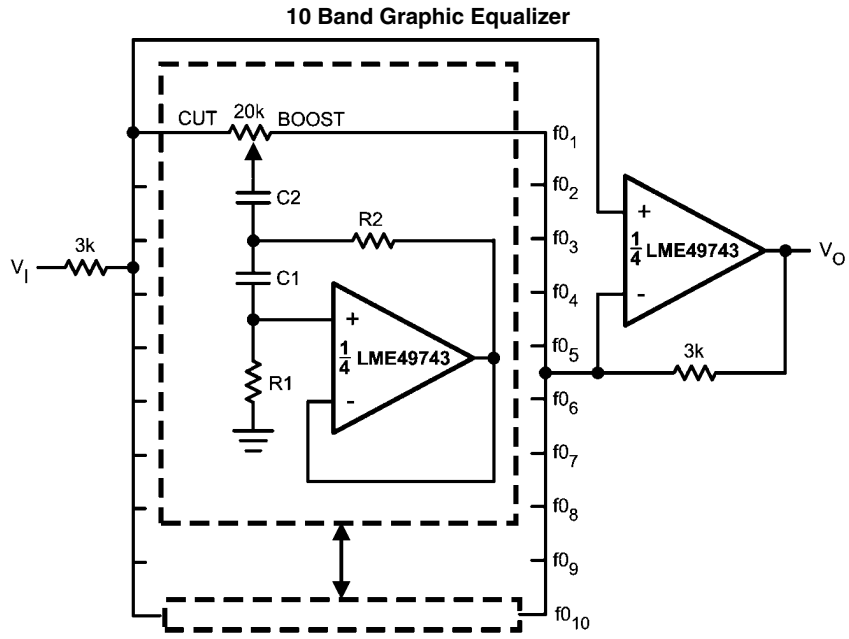

30048144

fo (Hz)	C ₁	C ₂	R ₁	R ₂
32	0.12μF	4.7μF	75kΩ	500Ω
64	0.056μF	3.3μF	68kΩ	510Ω
125	0.033μF	1.5μF	62kΩ	510Ω
250	0.015μF	0.82μF	68kΩ	470Ω
500	8200pF	0.39μF	62kΩ	470Ω
1k	3900pF	0.22μF	68kΩ	470Ω
2k	2000pF	0.1μF	68kΩ	470Ω
4k	1100pF	0.056μF	62kΩ	470Ω
8k	510pF	0.022μF	68kΩ	510Ω
16k	330pF	0.012μF	51kΩ	510Ω

Note 10: At volume of change = ±12 dB

Q = 1.7

Reference: "AUDIO/RADIO HANDBOOK", National Semiconductor, 1980, Page 2-61

Revision History

Rev	Date	Description
1.0	3/26/08	release to the web

Notes

Notes

For more National Semiconductor product information and proven design tools, visit the following Web sites at:

Products		Design Support	
Amplifiers	www.national.com/amplifiers	WEBENCH	www.national.com/webench
Audio	www.national.com/audio	Analog University	www.national.com/AU
Clock Conditioners	www.national.com/timing	App Notes	www.national.com/appnotes
Data Converters	www.national.com/adc	Distributors	www.national.com/contacts
Displays	www.national.com/displays	Green Compliance	www.national.com/quality/green
Ethernet	www.national.com/ethernet	Packaging	www.national.com/packaging
Interface	www.national.com/interface	Quality and Reliability	www.national.com/quality
LVDS	www.national.com/lvds	Reference Designs	www.national.com/refdesigns
Power Management	www.national.com/power	Feedback	www.national.com/feedback
Switching Regulators	www.national.com/switchers		
LDOs	www.national.com/lido		
LED Lighting	www.national.com/led		
PowerWise	www.national.com/powerwise		
Serial Digital Interface (SDI)	www.national.com/sdi		
Temperature Sensors	www.national.com/tempsensors		
Wireless (PLL/VCO)	www.national.com/wireless		

THE CONTENTS OF THIS DOCUMENT ARE PROVIDED IN CONNECTION WITH NATIONAL SEMICONDUCTOR CORPORATION ("NATIONAL") PRODUCTS. NATIONAL MAKES NO REPRESENTATIONS OR WARRANTIES WITH RESPECT TO THE ACCURACY OR COMPLETENESS OF THE CONTENTS OF THIS PUBLICATION AND RESERVES THE RIGHT TO MAKE CHANGES TO SPECIFICATIONS AND PRODUCT DESCRIPTIONS AT ANY TIME WITHOUT NOTICE. NO LICENSE, WHETHER EXPRESS, IMPLIED, ARISING BY ESTOPPEL OR OTHERWISE, TO ANY INTELLECTUAL PROPERTY RIGHTS IS GRANTED BY THIS DOCUMENT.

TESTING AND OTHER QUALITY CONTROLS ARE USED TO THE EXTENT NATIONAL DEEMS NECESSARY TO SUPPORT NATIONAL'S PRODUCT WARRANTY. EXCEPT WHERE MANDATED BY GOVERNMENT REQUIREMENTS, TESTING OF ALL PARAMETERS OF EACH PRODUCT IS NOT NECESSARILY PERFORMED. NATIONAL ASSUMES NO LIABILITY FOR APPLICATIONS ASSISTANCE OR BUYER PRODUCT DESIGN. BUYERS ARE RESPONSIBLE FOR THEIR PRODUCTS AND APPLICATIONS USING NATIONAL COMPONENTS. PRIOR TO USING OR DISTRIBUTING ANY PRODUCTS THAT INCLUDE NATIONAL COMPONENTS, BUYERS SHOULD PROVIDE ADEQUATE DESIGN, TESTING AND OPERATING SAFEGUARDS.

EXCEPT AS PROVIDED IN NATIONAL'S TERMS AND CONDITIONS OF SALE FOR SUCH PRODUCTS, NATIONAL ASSUMES NO LIABILITY WHATSOEVER, AND NATIONAL DISCLAIMS ANY EXPRESS OR IMPLIED WARRANTY RELATING TO THE SALE AND/OR USE OF NATIONAL PRODUCTS INCLUDING LIABILITY OR WARRANTIES RELATING TO FITNESS FOR A PARTICULAR PURPOSE, MERCHANTABILITY, OR INFRINGEMENT OF ANY PATENT, COPYRIGHT OR OTHER INTELLECTUAL PROPERTY RIGHT.

LIFE SUPPORT POLICY

NATIONAL'S PRODUCTS ARE NOT AUTHORIZED FOR USE AS CRITICAL COMPONENTS IN LIFE SUPPORT DEVICES OR SYSTEMS WITHOUT THE EXPRESS PRIOR WRITTEN APPROVAL OF THE CHIEF EXECUTIVE OFFICER AND GENERAL COUNSEL OF NATIONAL SEMICONDUCTOR CORPORATION. As used herein:

Life support devices or systems are devices which (a) are intended for surgical implant into the body, or (b) support or sustain life and whose failure to perform when properly used in accordance with instructions for use provided in the labeling can be reasonably expected to result in a significant injury to the user. A critical component is any component in a life support device or system whose failure to perform can be reasonably expected to cause the failure of the life support device or system or to affect its safety or effectiveness.

National Semiconductor and the National Semiconductor logo are registered trademarks of National Semiconductor Corporation. All other brand or product names may be trademarks or registered trademarks of their respective holders.

Copyright© 2008 National Semiconductor Corporation

For the most current product information visit us at www.national.com



**National Semiconductor
Americas Technical
Support Center**
Email:
new.feedback@nsc.com
Tel: 1-800-272-9959

**National Semiconductor Europe
Technical Support Center**
Email: europe.support@nsc.com
German Tel: +49 (0) 180 5010 771
English Tel: +44 (0) 870 850 4288

**National Semiconductor Asia
Pacific Technical Support Center**
Email: ap.support@nsc.com

**National Semiconductor Japan
Technical Support Center**
Email: jpn.feedback@nsc.com