

LME49871

High Performance, High Fidelity Current Feedback Audio Operational Amplifier

General Description

The LME49871 is an ultra-low distortion, low noise, ultra high slew rate current feedback operational amplifier optimized and fully specified for high performance, high fidelity applications. Combining advanced leading-edge process technology with state-of-the-art circuit design, the LME49871 current feedback operational amplifier delivers superior signal amplification for outstanding performance. Operating on a wide supply range of $\pm 5V$ to $\pm 22V$, the LME49871 combines extremely low voltage noise density ($1.9nV/\sqrt{Hz}$) with very low THD+N (0.00012%) to easily satisfy the most demanding applications. To ensure that the most challenging loads are driven without compromise, the LME49871 has a high slew rate of $\pm 1900V/\mu s$ and an output current capability of $\pm 100mA$. Further, dynamic range is maximized by an output stage that drives 150Ω loads to within 2.9V of either power supply voltage.

The LME49871's outstanding CMRR (88dB), PSRR (102dB), and V_{OS} (0.05mV) give the amplifier excellent operational amplifier DC performance.

The LME49871 is available in an 8-lead narrow body SOIC. Demonstration boards are available.

Key Specifications

■ Power Supply Voltage Range	$\pm 5V$ to $\pm 22V$
■ THD+N ($A_V = 1$, $R_L = 100\Omega$, $V_{OUT} = 2V_{P-P}$, $f = 1kHz$)	0.00021% (typ)
■ THD+N ($A_V = 1$, $R_L = 600\Omega$, $V_{OUT} = 1.4V_{RMS}$, $f = 1kHz$)	0.00012% (typ)
■ Input Noise Density	$1.9nV/\sqrt{Hz}$ (typ)
■ Slew Rate	$\pm 1900V/\mu s$ (typ)
■ Bandwidth ($A_V = 1$, $R_L = 2k\Omega$, $R_F = 800\Omega$)	213MHz (typ)
■ Input Bias Current	1.8 μA (typ)
■ Input Offset Voltage	0.05mV (typ)
■ PSRR	102dB (typ)
■ CMRR	90dB (typ)

Features

- Easily drives 150Ω loads
- Optimized for superior audio signal fidelity
- Output short circuit protection
- SOIC package

Applications

- Ultra high quality audio amplification
- High fidelity preamplifiers
- High fidelity multimedia
- State of the art phono pre amps
- High performance professional audio
- High fidelity equalization and crossover networks
- High performance line drivers
- High performance line receivers
- High fidelity active filters

Connection Diagrams

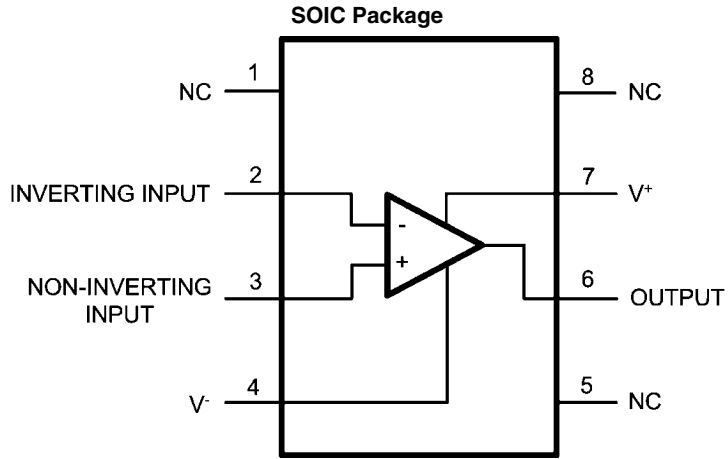

30042601

Order Number LME49871MA
See NS Package Number M08A

LME49871MA Top Mark

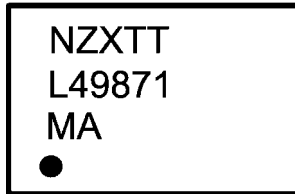

30042602

N = National Logo
Z = Assembly plant code
X = 1 Digit date code
TT = Die traceability
L49871 = LME49871
MA = Package code

Absolute Maximum Ratings (Notes 1, 2)

If Military/Aerospace specified devices are required, please contact the National Semiconductor Sales Office/Distributors for availability and specifications.

Power Supply Voltage ($V_S = V^+ - V^-$)	46V	ESD Rating (Note 4)	2000V
Storage Temperature	-65°C to 150°C	ESD Rating (Note 5)	
Input Voltage	(V-) - 0.7V to (V+) + 0.7V	Pins 1, 4, 7 and 8	200V
Output Short Circuit (Note 3)	Continuous	Pins 2, 3, 5 and 6	100V
Power Dissipation	Internally Limited	Junction Temperature	150°C
		Thermal Resistance	
		θ_{JA} (MA)	145°C/W
		Temperature Range	
		$T_{MIN} \leq T_A \leq T_{MAX}$	-40°C \leq T_A \leq 85°C
		Supply Voltage Range	$\pm 5.0V \leq V_S \leq \pm 22V$

Electrical Characteristics (Notes 1, 2) The following specifications apply for $\pm 22V$, $R_L = 2k\Omega$, $R_{SOURCE} = 10\Omega$, $f_{IN} = 1kHz$, and $T_A = 25^\circ C$, unless otherwise specified.

Symbol	Parameter	Conditions	LME49871		Units (Limits)
			Typical	Limit	
			(Note 6)	(Note 7)	
THD+N	Total Harmonic Distortion + Noise	$A_V = 1$, $f = 1kHz$, $R_F = 1.2k\Omega$	0.00021		%
		$R_L = 100\Omega$, $V_{OUT} = 3V_{RMS}$ $R_L = 600\Omega$, $V_{OUT} = 1.4V_{RMS}$	0.00012		%
IMD	Intermodulation Distortion	$A_V = 1$, $V_{IN} = 3V_{RMS}$ Two-tone, 60Hz & 7kHz 4:1	0.00009		%
BW	Bandwidth	$A_V = -1$, $R_F = 800\Omega$	213		MHz
SR	Slew Rate	$V_{OUT} = 20V_{P-P}$, $A_V = -5$	± 1900		V/ μs
FPBW	Full Power Bandwidth	$V_{OUT} = 20V_{P-P}$, -3dB referenced to output magnitude at $f = 1kHz$, $A_V = 1$	30		MHz
t_s	Settling Time	$A_V = -1$, 10V step, 0.1% error range	50		ns
e_n	Equivalent Input Noise Voltage	$f_{BW} = 20Hz$ to 20kHz	0.26	0.6	μV_{RMS} (max)
	Equivalent Input Noise Density	$f = 1kHz$ $f = 10Hz$	1.9 11.5	4.0	nV/ \sqrt{Hz} (max)
i_n	Current Noise Density	$f = 1kHz$	16		pA/ \sqrt{Hz}
		$f = 10Hz$	160		pA/ \sqrt{Hz}
V_{OS}	Input Offset Voltage		± 0.05	± 1.0	mV (max)
$\Delta V_{OS}/\Delta Temp$	Average Input Offset Voltage Drift vs Temperature	-40°C \leq T_A \leq 85°C	0.29		$\mu V/^\circ C$
PSRR	Average Input Offset Voltage Shift vs Power Supply Voltage	$V_S = \pm 22V$, $\Delta V_S = 30V$ (Note 8)	102	100	dB (min)
I_B	Input Bias Current	$V_{CM} = 0V$	1.8	6	μA (max)
$\Delta I_{OS}/\Delta Temp$	Input Bias Current Drift vs Temperature	-40°C \leq T_A \leq 85°C			
		Inverting input Non-inverting input	4.5 4.7		nA/ $^\circ C$ nA/ $^\circ C$
I_{OS}	Input Offset Current	$V_{CM} = 0V$	1.3	5	μA (max)
V_{IN-CM}	Common-Mode Input Voltage Range	$V_S = \pm 22V$	± 20.5	(V+) - 1.0 (V-) + 1.0	V (min) V (min)
CMRR	Common-Mode Rejection	-10V \leq $V_{CM} \leq$ 10V	90	86	dB (min)
Z_{IN}	Non-inverting-input Input Impedance	-10V \leq $V_{CM} \leq$ 10V	1.2		M Ω
	Inverting-input Input Impedance	-10V \leq $V_{CM} \leq$ 10V	58		Ω
Z_T	Transimpedance	$V_{OUT} = \pm 10V$			
		$R_L = 200\Omega$	4.2	2.0	M Ω (min)
		$R_L = \infty$	4.7	2.65	M Ω (min)

Symbol	Parameter	Conditions	LME49871		Units (Limits)
			Typical	Limit	
			(Note 6)	(Note 7)	
V _{OUTMAX}	Maximum Output Voltage Swing	R _L = 150Ω	±18.6	±17.6	V (min)
		R _L = 600Ω	±19.4	±18.4	V (min)
I _{OUT}	Output Current	R _L = 150Ω, V _S = ±22V	±100	±93	mA (min)
I _{OUT-CC}	Instantaneous Short Circuit Current		±140		mA
R _{OUT}	Output Resistance	f _{IN} = 5MHz Open-Loop	10		Ω
I _S	Total Quiescent Current	I _{OUT} = 0mA	8.3	9.5	mA (max)

Note 1: "Absolute Maximum Ratings" indicate limits beyond which damage to the device may occur, including inoperability and degradation of device reliability and/or performance. Functional operation of the device and/or non-degradation at the *Absolute Maximum Ratings* or other conditions beyond those indicated in the *Recommended Operating Conditions* is not implied. The *Recommended Operating Conditions* indicate conditions at which the device is functional and the device should not be operated beyond such conditions. All voltages are measured with respect to the ground pin, unless otherwise specified.

Note 2: The *Electrical Characteristics* tables list guaranteed specifications under the listed *Recommended Operating Conditions* except as otherwise modified or specified by the *Electrical Characteristics Conditions* and/or Notes. Typical specifications are estimations only and are not guaranteed.

Note 3: Amplifier output connected to GND, any number of amplifiers within a package.

Note 4: Human body model, applicable std. JESD22-A114C.

Note 5: Machine model, applicable std. JESD22-A115-A.

Note 6: Typical values represent most likely parametric norms at T_A = +25°C, and at the *Recommended Operation Conditions* at the time of product characterization and are not guaranteed.

Note 7: Datasheet min/max specification limits are guaranteed by test or statistical analysis.

Note 8: PSRR is measured as follows: V_{OS} is measured at two supply voltages, ±7V and ±22V. PSRR = |20log(ΔV_{OS}/ΔV_S)|.

Typical Performance Characteristics

FFT of 1kHz Sinewave, 0dB Input Magnitude

$V_{OUT} = 3V_{RMS}$, $R_L = 1k\Omega$, $V_S = \pm 15V$, $A_V = 1$

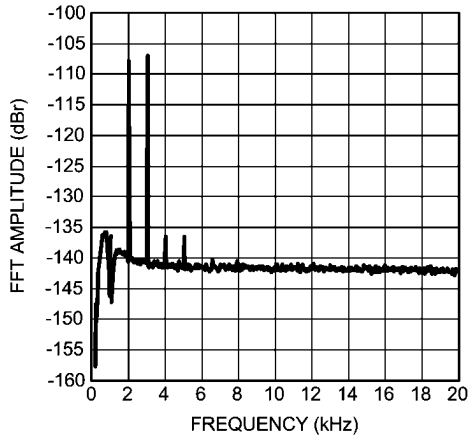

30042619

FFT of 1kHz Sinewave, 0dB Input Magnitude

$V_{OUT} = 3V_{RMS}$, $R_L = 100\Omega$, $V_S = \pm 15V$, $A_V = 1$

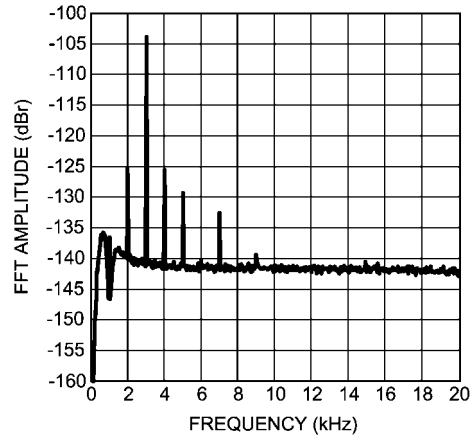

30042620

FFT of 1kHz Sinewave, 0dB Input Magnitude

$V_{OUT} = 3V_{RMS}$, $R_L = 600\Omega$, $V_S = \pm 15V$, $A_V = 1$

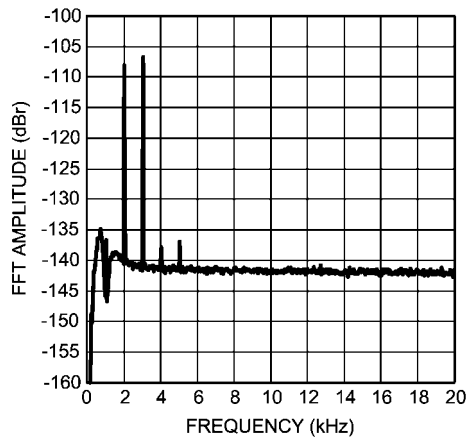

30042621

FFT of 1kHz Sinewave, 0dB Input Magnitude

$V_{OUT} = 1.4V_{RMS}$, $R_L = 1k\Omega$, $V_S = \pm 15V$, $A_V = 1$

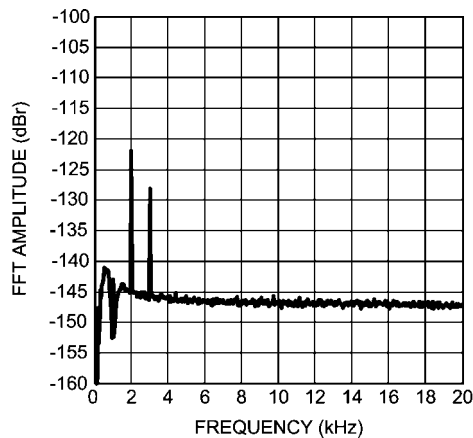

30042616

FFT of 1kHz Sinewave, 0dB Input Magnitude

$V_{OUT} = 1.4V_{RMS}$, $R_L = 100\Omega$, $V_S = \pm 15V$, $A_V = 1$

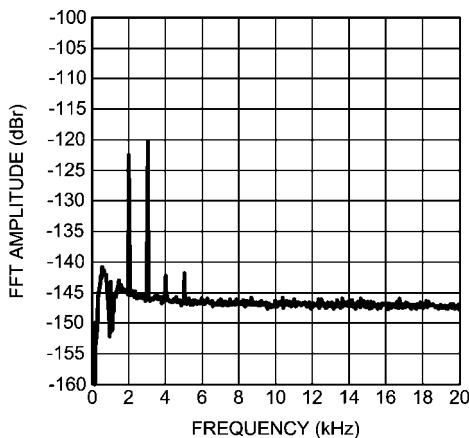

30042617

FFT of 1kHz Sinewave, 0dB Input Magnitude

$V_{OUT} = 1.4V_{RMS}$, $R_L = 600\Omega$, $V_S = \pm 15V$, $A_V = 1$

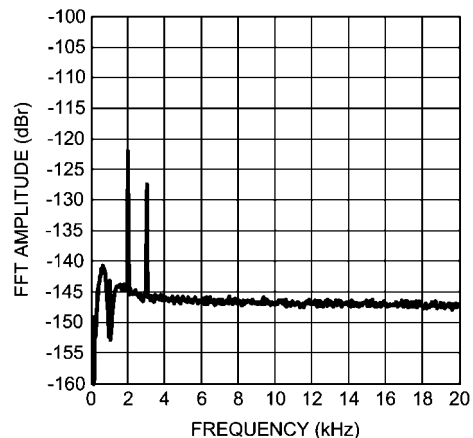

30042618

FFT of 1kHz Sinewave, 0dB Input Magnitude
 $V_{OUT} = 3V_{RMS}$, $R_L = 1k\Omega$, $V_S = \pm 22V$, $A_V = 1$

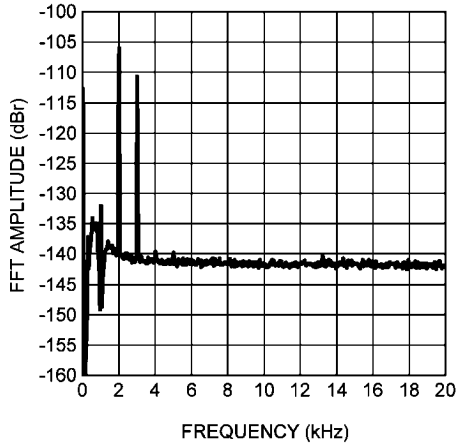

30042681

FFT of 1kHz Sinewave, 0dB Input Magnitude
 $V_{OUT} = 3V_{RMS}$, $R_L = 100\Omega$, $V_S = \pm 22V$, $A_V = 1$

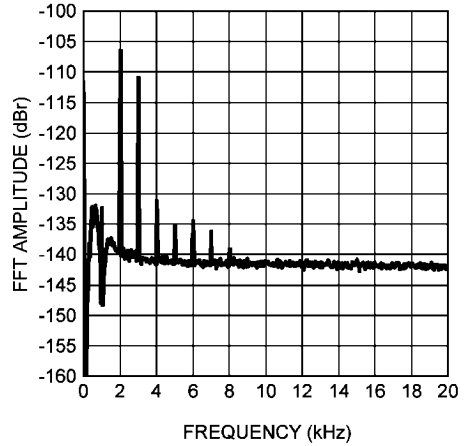

30042682

FFT of 1kHz Sinewave, 0dB Input Magnitude
 $V_{OUT} = 3V_{RMS}$, $R_L = 600\Omega$, $V_S = \pm 22V$, $A_V = 1$

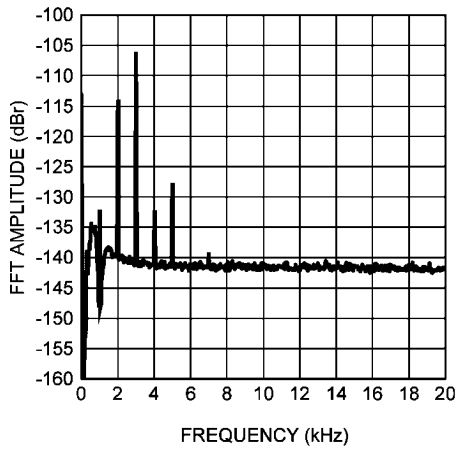

30042680

FFT of 1kHz Sinewave, 0dB Input Magnitude
 $V_{OUT} = 1.4V_{RMS}$, $R_L = 1k\Omega$, $V_S = \pm 22V$, $A_V = 1$

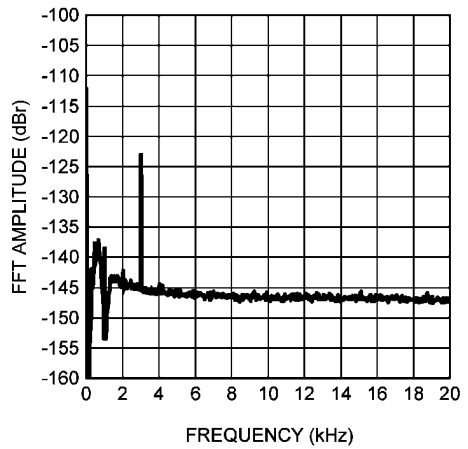

30042677

FFT of 1kHz Sinewave, 0dB Input Magnitude
 $V_{OUT} = 1.4V_{RMS}$, $R_L = 100\Omega$, $V_S = \pm 22V$, $A_V = 1$

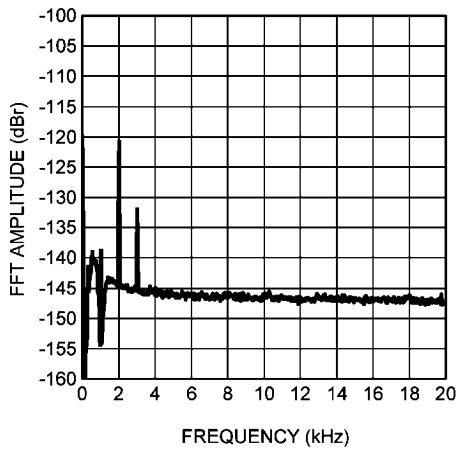

30042678

FFT of 1kHz Sinewave, 0dB Input Magnitude
 $V_{OUT} = 1.4V_{RMS}$, $R_L = 600\Omega$, $V_S = \pm 22V$, $A_V = 1$

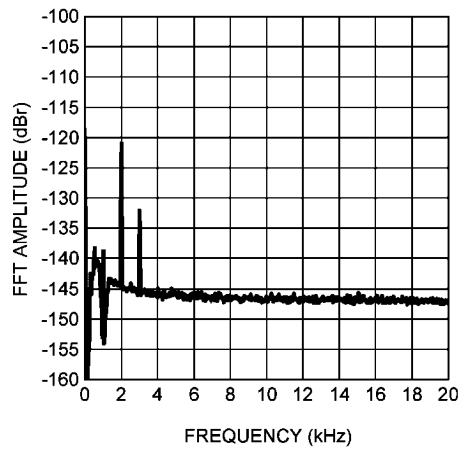

30042679

Output Voltage vs Supply Voltage
 $A_V = 1, R_L = 600\Omega, 1\% \text{ THD+N}$

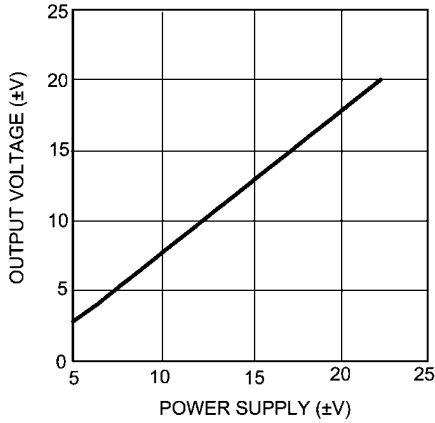

30042687

Output Voltage vs Supply Voltage
 $A_V = 1, R_L = \text{open}, 1\% \text{ THD+N}$

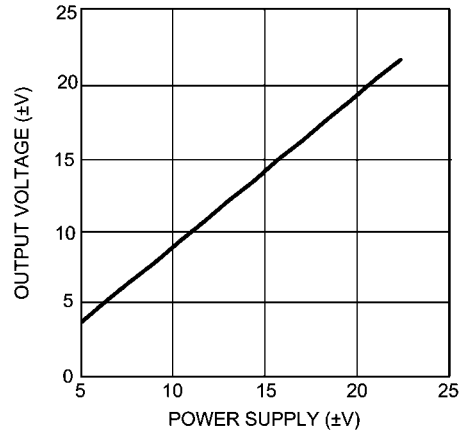

30042688

Supply Current (I_{CC}) vs Power Supply
 $R_L = \text{open}$

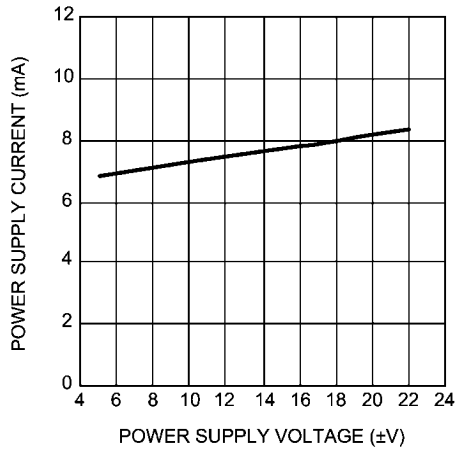

30042689

Gain vs Frequency
 $V_S = \pm 15V, G = -1$

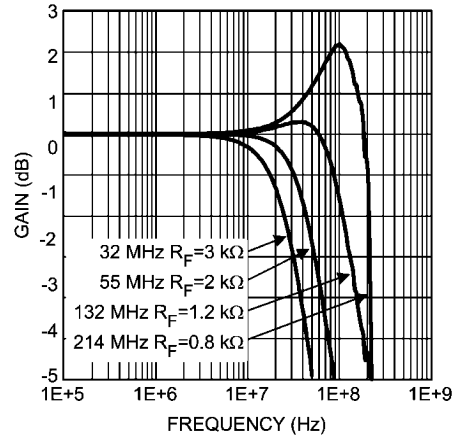

30042604

Gain vs Frequency
 $V_S = \pm 15V, G = -2$

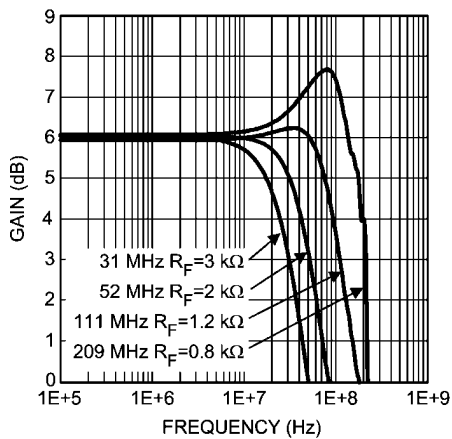

30042605

Gain vs Frequency
 $V_S = \pm 15V, G = -5$

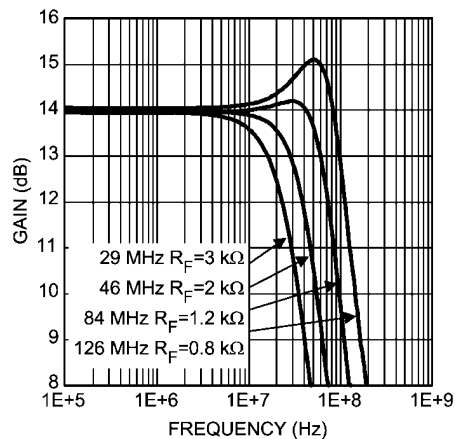

30042606

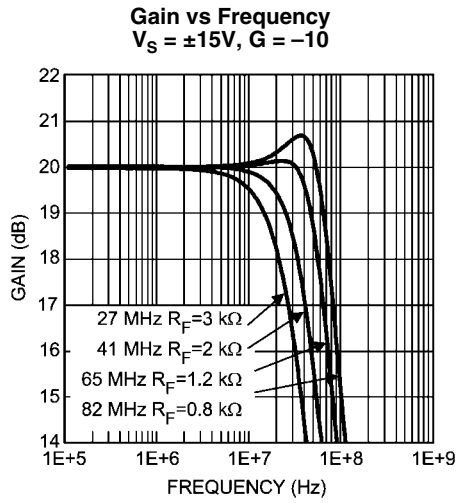

30042607

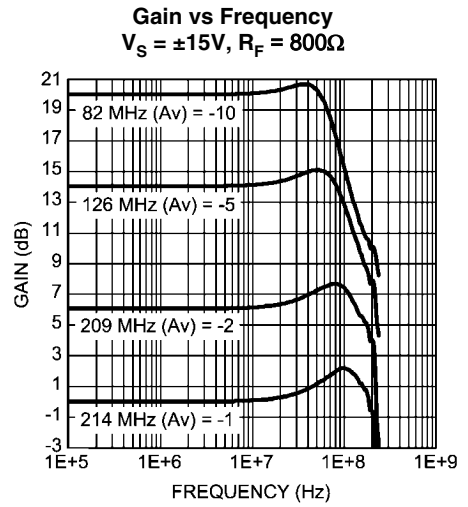

30042608

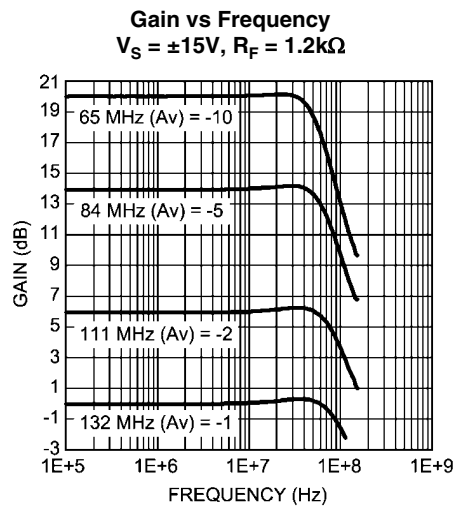

30042609

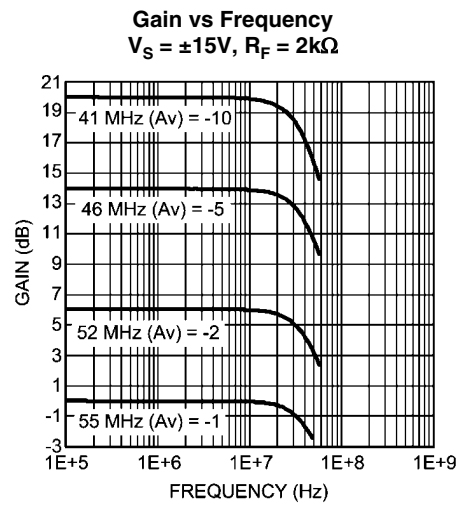

30042610

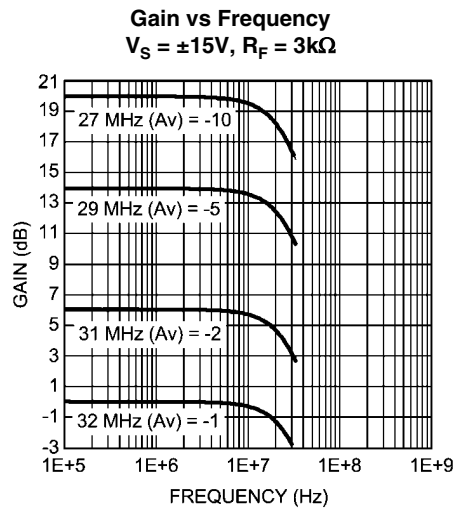

30042611

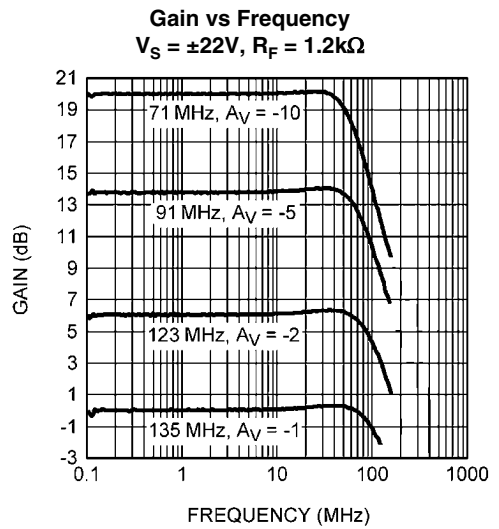

30042683

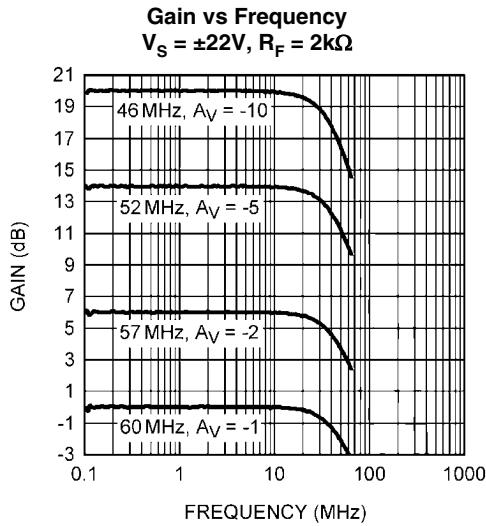

30042684

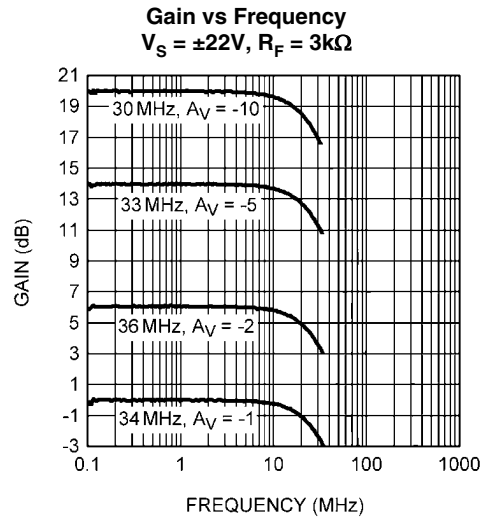

30042685

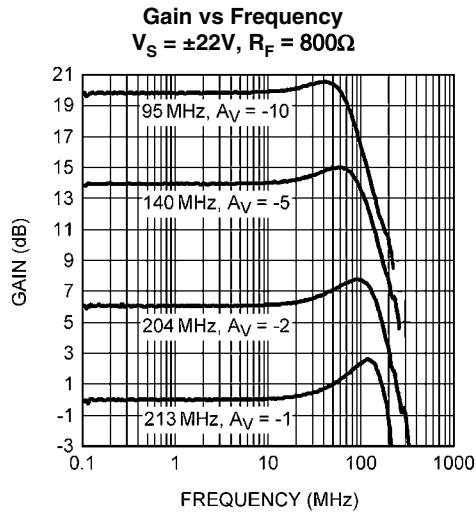

30042686

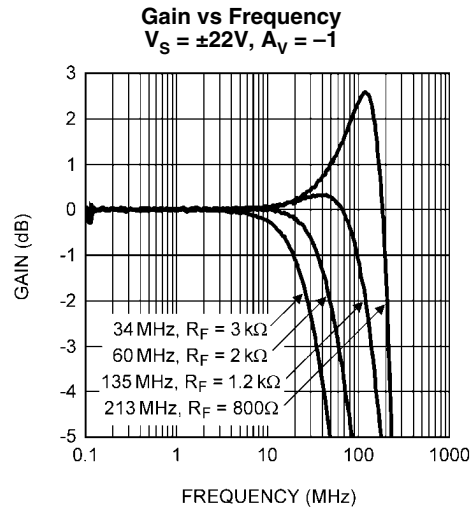

30042671

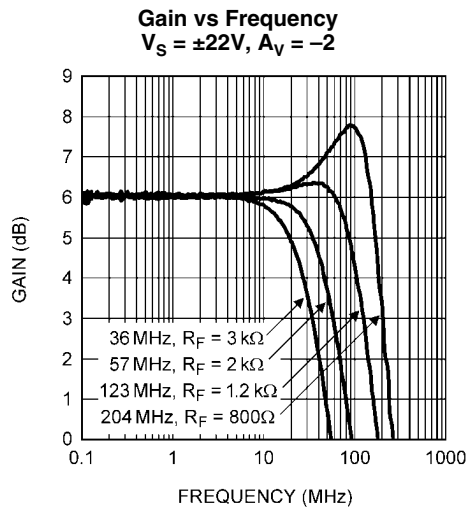

30042673

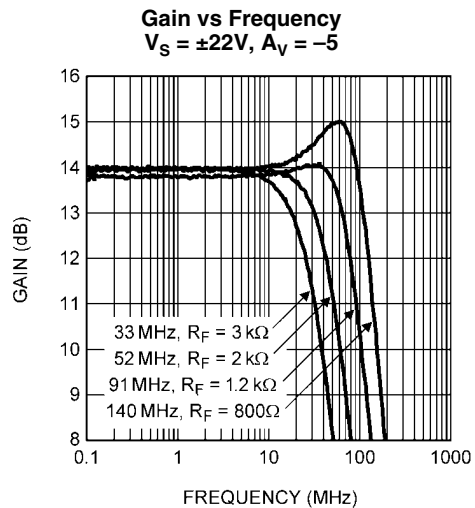

30042675

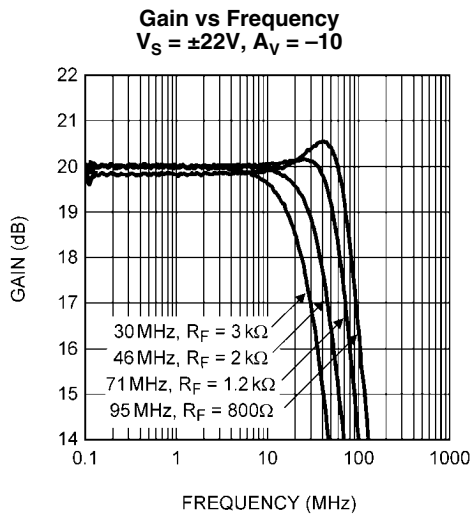

30042670

Application Information

GENERAL AMPLIFIER FUNCTION

oltage feedback amplifiers have a small-signal bandwidth that is a function of the closed-loop gain. Conversely, the LME49871 current feedback amplifier features a small-signal bandwidth that is relatively independent of the closed-loop gain. This is shown in *Figure 1* where the LME49871's gain is -1 , -2 , -5 and -10 . Like all current feedback amplifiers, the LME49871's closed-loop bandwidth is a function of the feedback resistance value. Therefore, R_s must be varied to select the desired closed-loop gain.

POWER SUPPLY BYPASSING AND LAYOUT CONSIDERATIONS

Properly placed and correctly valued supply bypassing is essential for optimized high-speed amplifier operation. The supply bypassing must maintain a wideband, low-impedance capacitive connection between the amplifier's supply pin and ground. This helps preserve high speed signal and fast transient fidelity. The bypassing is easily accomplished using a parallel combination of a $10\mu\text{F}$ tantalum and a $0.1\mu\text{F}$ ceramic capacitors for each power supply pin. The bypass capacitors should be placed as close to the amplifier power supply pins as possible.

FEEDBACK RESISTOR SELECTION (R_f)

The value of the R_f is also a dominant factor in compensating the LME49871. For general applications, the LME49871 will maintain specified performance with an $1.2\text{k}\Omega$ feedback resistor. Although this value will provide good results for most applications, it may be advantageous to adjust this value slightly for best pulse response optimized for the desired bandwidth. In addition to reducing bandwidth, increasing the feedback resistor value also reduces overshoot in the time domain response.

SLEW RATE CONSIDERATIONS

A current feedback amplifier's slew rate characteristics are different than that of voltage feedback amplifiers. A voltage feedback amplifier's slew rate limiting or non-linear amplifier behavior is dominated by the finite availability of the first stage tail current charging the second stage voltage amplifier's compensation capacitor. Conversely, a current feedback amplifier's slew rate is not constant. Transient current at the inverting input determines slew rate for both inverting and non-inverting gains. The non-inverting configuration slew rate is also determined by input stage limitations. Accordingly, variations of slew rates occur for different circuit topologies.

DRIVING CAPACITIVE LOADS

The LME49871 can drive significantly higher capacitive loads than many current feedback amplifiers. Although the LME49871 can directly drive as much as 100pF without oscillating, the resulting response will be a function of the feedback resistor value.

CAPACITIVE FEEDBACK

It is quite common to place a small lead-compensation capacitor in parallel with a voltage feedback amplifier's feedback resistance, R_f . This compensation reduces the amplifier's peaking in the frequency domain and damps the transient response. Whereas this yields the expected results when used with voltage feedback amplifiers, this technique must not be used with current feedback amplifiers. The dynamic impedance of capacitors in the feedback loop reduces the amplifier's stability. Instead, reduced peaking in the frequency response and bandwidth limiting can be accomplished by adding an RC circuit to the amplifier's input.

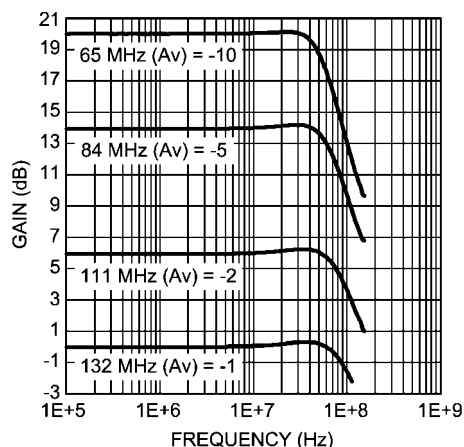

300426p0

FIGURE 1. Bandwidth as a function of gain

Revision History

Rev	Date	Description
1.0	04/24/08	Initial release.
1.01	04/28/08	Changed the Limit values on V_{IN-CM} from -2.0 and $+2.0$ to -1.0 and $+1.0$.

Physical Dimensions inches (millimeters) unless otherwise noted

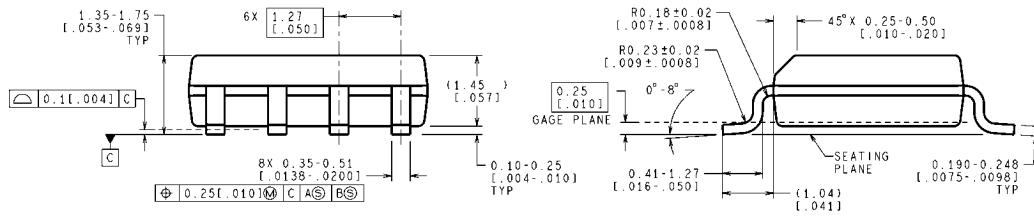
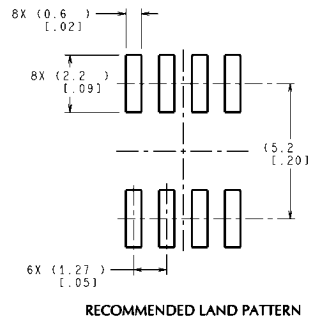
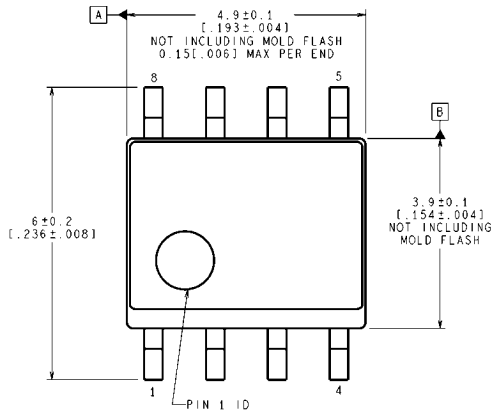

CONTROLLING DIMENSION IS MILLIMETER
 VALUES IN [] ARE INCHES
 DIMENSIONS IN () FOR REFERENCE ONLY

M08A (Rev L)

SOIC Package
Order Number LME49871MA
NS Package Number M08A

Notes

For more National Semiconductor product information and proven design tools, visit the following Web sites at:

Products		Design Support	
Amplifiers	www.national.com/amplifiers	WEBENCH	www.national.com/webench
Audio	www.national.com/audio	Analog University	www.national.com/AU
Clock Conditioners	www.national.com/timing	App Notes	www.national.com/appnotes
Data Converters	www.national.com/adc	Distributors	www.national.com/contacts
Displays	www.national.com/displays	Green Compliance	www.national.com/quality/green
Ethernet	www.national.com/ethernet	Packaging	www.national.com/packaging
Interface	www.national.com/interface	Quality and Reliability	www.national.com/quality
LVDS	www.national.com/lvds	Reference Designs	www.national.com/refdesigns
Power Management	www.national.com/power	Feedback	www.national.com/feedback
Switching Regulators	www.national.com/switchers		
LDOs	www.national.com/ldo		
LED Lighting	www.national.com/led		
PowerWise	www.national.com/powerwise		
Serial Digital Interface (SDI)	www.national.com/sdi		
Temperature Sensors	www.national.com/tempsensors		
Wireless (PLL/VCO)	www.national.com/wireless		

THE CONTENTS OF THIS DOCUMENT ARE PROVIDED IN CONNECTION WITH NATIONAL SEMICONDUCTOR CORPORATION ("NATIONAL") PRODUCTS. NATIONAL MAKES NO REPRESENTATIONS OR WARRANTIES WITH RESPECT TO THE ACCURACY OR COMPLETENESS OF THE CONTENTS OF THIS PUBLICATION AND RESERVES THE RIGHT TO MAKE CHANGES TO SPECIFICATIONS AND PRODUCT DESCRIPTIONS AT ANY TIME WITHOUT NOTICE. NO LICENSE, WHETHER EXPRESS, IMPLIED, ARISING BY ESTOPPEL OR OTHERWISE, TO ANY INTELLECTUAL PROPERTY RIGHTS IS GRANTED BY THIS DOCUMENT.

TESTING AND OTHER QUALITY CONTROLS ARE USED TO THE EXTENT NATIONAL DEEMS NECESSARY TO SUPPORT NATIONAL'S PRODUCT WARRANTY. EXCEPT WHERE MANDATED BY GOVERNMENT REQUIREMENTS, TESTING OF ALL PARAMETERS OF EACH PRODUCT IS NOT NECESSARILY PERFORMED. NATIONAL ASSUMES NO LIABILITY FOR APPLICATIONS ASSISTANCE OR BUYER PRODUCT DESIGN. BUYERS ARE RESPONSIBLE FOR THEIR PRODUCTS AND APPLICATIONS USING NATIONAL COMPONENTS. PRIOR TO USING OR DISTRIBUTING ANY PRODUCTS THAT INCLUDE NATIONAL COMPONENTS, BUYERS SHOULD PROVIDE ADEQUATE DESIGN, TESTING AND OPERATING SAFEGUARDS.

EXCEPT AS PROVIDED IN NATIONAL'S TERMS AND CONDITIONS OF SALE FOR SUCH PRODUCTS, NATIONAL ASSUMES NO LIABILITY WHATSOEVER, AND NATIONAL DISCLAIMS ANY EXPRESS OR IMPLIED WARRANTY RELATING TO THE SALE AND/OR USE OF NATIONAL PRODUCTS INCLUDING LIABILITY OR WARRANTIES RELATING TO FITNESS FOR A PARTICULAR PURPOSE, MERCHANTABILITY, OR INFRINGEMENT OF ANY PATENT, COPYRIGHT OR OTHER INTELLECTUAL PROPERTY RIGHT.

LIFE SUPPORT POLICY

NATIONAL'S PRODUCTS ARE NOT AUTHORIZED FOR USE AS CRITICAL COMPONENTS IN LIFE SUPPORT DEVICES OR SYSTEMS WITHOUT THE EXPRESS PRIOR WRITTEN APPROVAL OF THE CHIEF EXECUTIVE OFFICER AND GENERAL COUNSEL OF NATIONAL SEMICONDUCTOR CORPORATION. As used herein:

Life support devices or systems are devices which (a) are intended for surgical implant into the body, or (b) support or sustain life and whose failure to perform when properly used in accordance with instructions for use provided in the labeling can be reasonably expected to result in a significant injury to the user. A critical component is any component in a life support device or system whose failure to perform can be reasonably expected to cause the failure of the life support device or system or to affect its safety or effectiveness.

National Semiconductor and the National Semiconductor logo are registered trademarks of National Semiconductor Corporation. All other brand or product names may be trademarks or registered trademarks of their respective holders.

Copyright© 2008 National Semiconductor Corporation
For the most current product information visit us at www.national.com



**National Semiconductor
Americas Technical
Support Center**
Email:
new.feedback@nsc.com
Tel: 1-800-272-9959

**National Semiconductor Europe
Technical Support Center**
Email: europe.support@nsc.com
German Tel: +49 (0) 180 5010 771
English Tel: +44 (0) 870 850 4288

**National Semiconductor Asia
Pacific Technical Support Center**
Email: ap.support@nsc.com

**National Semiconductor Japan
Technical Support Center**
Email: jpn.feedback@nsc.com