

LMH0024

3.3V SMPTE 259M / 344M Adaptive Cable Equalizer

General Description

The LMH0024 SMPTE 259M / 344M adaptive cable equalizer is a monolithic integrated circuit for equalizing data transmitted over cable (or any media with similar dispersive loss characteristics). The equalizer operates over a wide range of data rates from 143 Mbps to 540 Mbps and supports SMPTE 259M and SMPTE 344M.

The LMH0024 implements DC restoration to correctly handle pathological data conditions. DC restoration can be bypassed for low data rate applications. The equalizer is flexible in allowing either single-ended or differential input drive.

Additional features include a mute pin which can be used to manually mute the output and a cable length indicator which determines the amount of cable being equalized.

Features

- SMPTE 259M and SMPTE 344M compliant
- Supports DVB-ASI at 270 Mbps
- Data rates: 143 Mbps to 540 Mbps
- Equalizes up to 350 meters of Belden 1694A at 270 Mbps
- Manual bypass, cable length indicator, and output mute
- Single-ended or differential input
- 50Ω differential outputs
- Single 3.3V supply operation
- Industrial temperature range: -40°C to +85°C
- 198mW typical power consumption with 3.3V supply
- Footprint compatible with the LMH0034 and the GS9064

Applications

- SMPTE 259M and SMPTE 344M serial digital interfaces
- Serial digital data equalization and reception
- Data recovery equalization

Typical Application

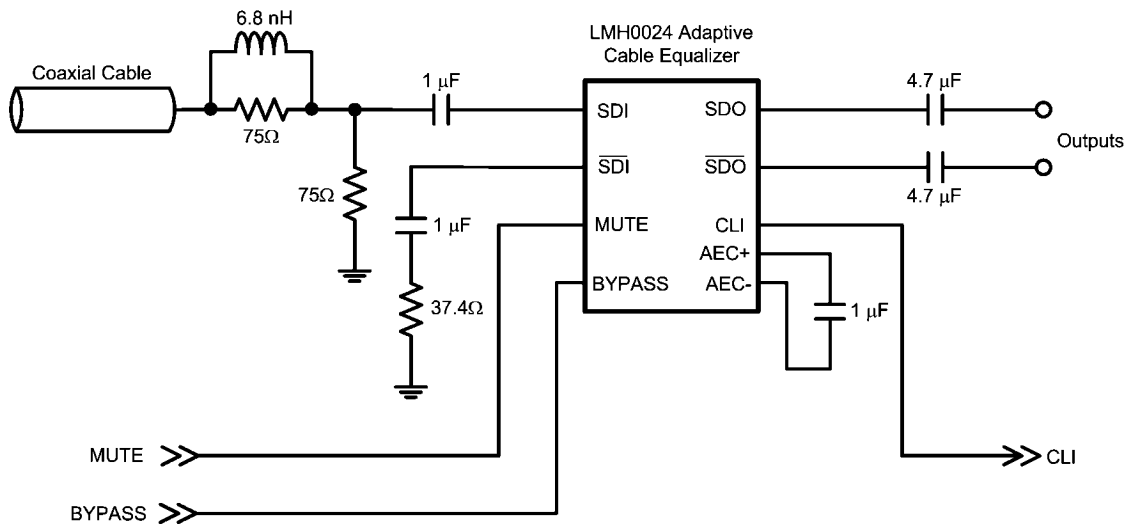

20172501

Absolute Maximum Ratings (Note 1)

Supply Voltage	-0.5V to 3.6V
Input Voltage (all inputs)	-0.3V to $V_{CC}+0.3V$
Storage Temperature Range	-65°C to +150°C
Junction Temperature	+150°C
Lead Temperature (Soldering 4 Sec)	+260°C
Package Thermal Resistance	
θ_{JA} 16-pin SOIC	+115°C/W
θ_{JC} 16-pin SOIC	+105°C/W
ESD Rating (HBM)	8kV
ESD Rating (MM)	250V

Recommended Operating Conditions

Supply Voltage ($V_{CC} - V_{EE}$)	3.3V \pm 5%
Input Coupling Capacitance	1.0 μ F
AEC Capacitor (Connected between AEC+ and AEC-)	1.0 μ F
Operating Free Air Temperature (T_A)	-40°C to +85°C

DC Electrical Characteristics

Over Supply Voltage and Operating Temperature ranges, unless otherwise specified (Notes 2, 3).

Symbol	Parameter	Conditions	Reference	Min	Typ	Max	Units
V_{CMIN}	Input Common Mode Voltage		SDI, \overline{SDI}		1.9		V
V_{SDI}	Input Voltage Swing	At LMH0024 input, (Notes 4, 6)		720	800	950	mV _{P-P}
V_{CMOUT}	Output Common Mode Voltage		SDO, \overline{SDO}		$V_{CC} - V_{SDO}/2$		V
V_{SDO}	Output Voltage Swing	50 Ω load, differential			750		mV _{P-P}
	CLI DC Voltage	0m cable	CLI		2.5		V
		no signal			1.2		V
	MUTE Input Voltage	Min to mute outputs	MUTE	3.0			V
		Max to force outputs active				2.0	V
I_{CC}	Supply Current	(Note 7)			60	77	mA

AC Electrical Characteristics

Over Supply Voltage and Operating Temperature ranges, unless otherwise specified (Note 3).

Symbol	Parameter	Conditions	Reference	Min	Typ	Max	Units
BR_{SDI}	Input Data Rate		SDI, \overline{SDI}	143		540	Mbps
	Maximum Equalized Cable Length (with equalizer pathological)	270 Mbps, Belden 1694A, 0.2UI output jitter, (Note 4)			350		m
		270 Mbps, Belden 8281, 0.2UI output jitter, (Note 4)			280		m
		540 Mbps, Belden 1694A, 0.2UI output jitter, (Note 4)			250		m
		540 Mbps, Belden 8281, 0.2UI output jitter, (Note 4)			180		m
t_r, t_f	Output Rise Time, Fall Time	20% – 80%, (Note 4)	SDO, \overline{SDO}		100	220	ps
	Mismatch in Rise/Fall Time	(Note 4)			2	15	ps
t_{OS}	Output Overshoot	(Note 4)			1	5	%
R_{OUT}	Output Resistance	single-ended, (Note 5)			50		Ω
RL_{IN}	Input Return Loss	(Note 8)	SDI, \overline{SDI}	15	18-20		dB
R_{IN}	Input Resistance	single-ended			1.3		$k\Omega$
C_{IN}	Input Capacitance	single-ended, (Note 5)			1		pF

Note 1: "Absolute Maximum Ratings" are those parameter values beyond which the life and operation of the device cannot be guaranteed. The stating herein of these maximums shall not be construed to imply that the device can or should be operated at or beyond these values. The table of "Electrical Characteristics" specifies acceptable device operating conditions.

Note 2: Current flow into device pins is defined as positive. Current flow out of device pins is defined as negative. All voltages are stated referenced to $V_{EE} = 0$ Volts.

Note 3: Typical values are stated for $V_{CC} = +3.3V$ and $T_A = +25^\circ C$.

Note 4: Specification is guaranteed by characterization.

Note 5: Specification is guaranteed by design.

Note 6: The maximum input voltage swing assumes a nonstressing, DC-balance signal; specifically, the SMPTE-recommended color bar test signal. Pathological or other stressing signals may not be used. This specification is for 0m cable only.

Note 7: Supply current depends on the amount of cable being equalized. The current is highest for short cable and decreases as the cable length is increased. Refer to *Figure 1*.

Note 8: Input return loss is dependent on board design. The LMH0024 meets this specification on the SD024 evaluation board from 5MHz to 1.5GHz.

Connection Diagram

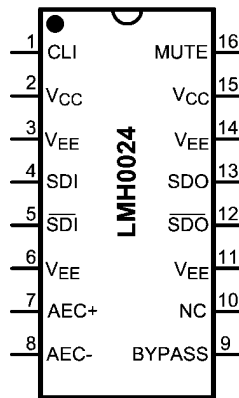

20172503
16-Pin SOIC
Order Number LMH0024MA
See NS Package Number M16A

Pin Descriptions

Pin #	Name	Description
1	CLI	Cable length indicator. Provides a voltage inversely proportional to the cable length being equalized.
2	V _{CC}	Positive power supply (+3.3V).
3	V _{EE}	Negative power supply (ground).
4	SDI	Serial data true input.
5	$\overline{\text{SDI}}$	Serial data complement input.
6	V _{EE}	Negative power supply (ground).
7	AEC+	AEC loop filter external capacitor (1 μ F) positive connection.
8	AEC-	AEC loop filter external capacitor (1 μ F) negative connection.
9	BYPASS	Bypasses equalization and DC restoration when high. No equalization occurs in this mode.
10	NC	No connect.
11	V _{EE}	Negative power supply (ground).
12	$\overline{\text{SDO}}$	Serial data complement output.
13	SDO	Serial data true output.
14	V _{EE}	Negative power supply (ground).
15	V _{CC}	Positive power supply (+3.3V).
16	MUTE	Output mute. To force SDO and $\overline{\text{SDO}}$ to mute, tie to V _{CC} . To disable MUTE, tie to GND. Typical application is MUTE tied to GND to enable the outputs. MUTE must be tied either high or low; it may not be left unconnected.

Block Diagram

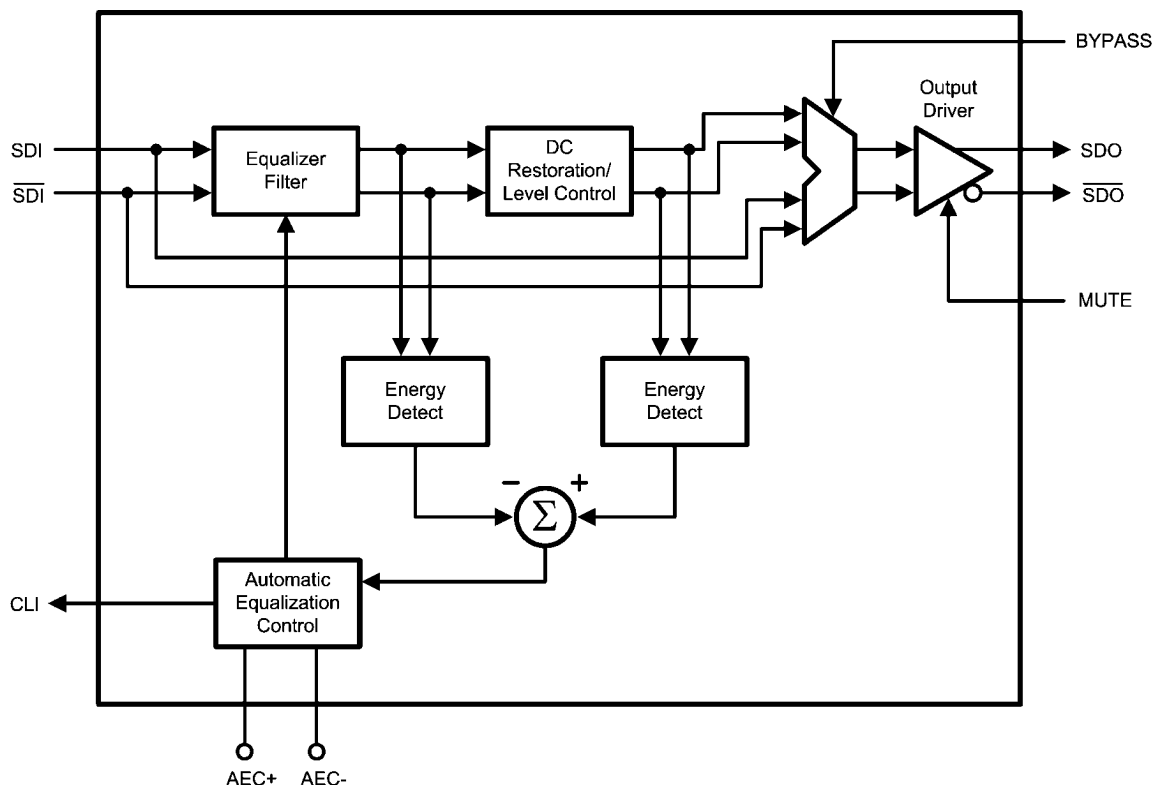

20172502

Device Operation

BLOCK DESCRIPTION

The **Equalizer Filter** block is a multi-stage adaptive filter. If Bypass is high, the equalizer filter is disabled.

The **DC Restoration / Level Control** block receives the differential signals from the equalizer filter block. This block incorporates a self-biasing DC restoration circuit to fully DC restore the signals. If Bypass is high, this function is disabled.

The signals before and after the DC Restoration / Level Control block are used to generate the **Automatic Equalization Control (AEC)** signal. This control signal sets the gain and bandwidth of the equalizer filter. The loop response in the AEC block is controlled by an external $1\mu\text{F}$ capacitor placed across the AEC+ and AEC- pins. **Cable Length Indicator (CLI)** is derived from this block.

The **Output Driver** produces SDO and $\overline{\text{SDO}}$. SDO and $\overline{\text{SDO}}$ may be forced to mute by activating **MUTE**.

CABLE LENGTH INDICATOR (CLI)

The cable length indicator provides a voltage to indicate the length of cable being equalized. The CLI voltage decreases as the cable length increases.

MUTE

MUTE can be used to manually mute or enable the LMH0024 outputs. MUTE must be tied to a low-level input or ground for SDO and $\overline{\text{SDO}}$ to be active. Applying a high input to MUTE will mute the LMH0024 outputs.

INPUT INTERFACING

The LMH0024 accepts either differential or single-ended input. The input must be AC coupled. Transformer coupling is not supported.

The LMH0024 correctly handles equalizer pathological signals for standard definition serial digital video, as described in SMPTE RP 178.

OUTPUT INTERFACING

The SDO and $\overline{\text{SDO}}$ outputs are internally loaded with 50Ω . They produce a $750\text{ mV}_{\text{P-P}}$ differential output, or a $375\text{ mV}_{\text{P-P}}$ single-ended output.

Application Information

PCB LAYOUT RECOMMENDATIONS

Please refer to the following Application Note for the CLC034 on National's website: **AN-1372, "LMH0034 PCB Layout Techniques."** The PCB layout techniques in this application note apply to the LMH0024 as well.

REPLACING THE GENNUM GS9064

The LMH0024 is footprint compatible with the Gennum GS9064. Pin 16 (MUTE) of the LMH0024 must be connect to ground for correct operation.

SUPPLY CURRENT VS. CABLE LENGTH

The supply current (I_{CC}) depends on the amount of cable being equalized. The current is highest for short cable and decreases as the cable length is increased. *Figure 1* shows supply current vs. Belden 1694A cable length for 270 Mbps data.

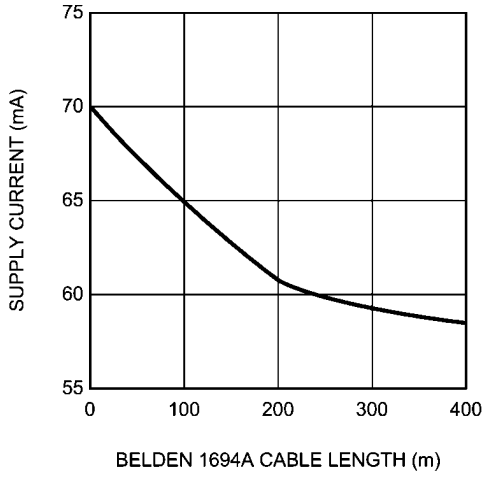

20172515

FIGURE 1. Supply Current vs. Belden 1694A Cable Length, 270 Mbps

Physical Dimensions inches (millimeters) unless otherwise noted

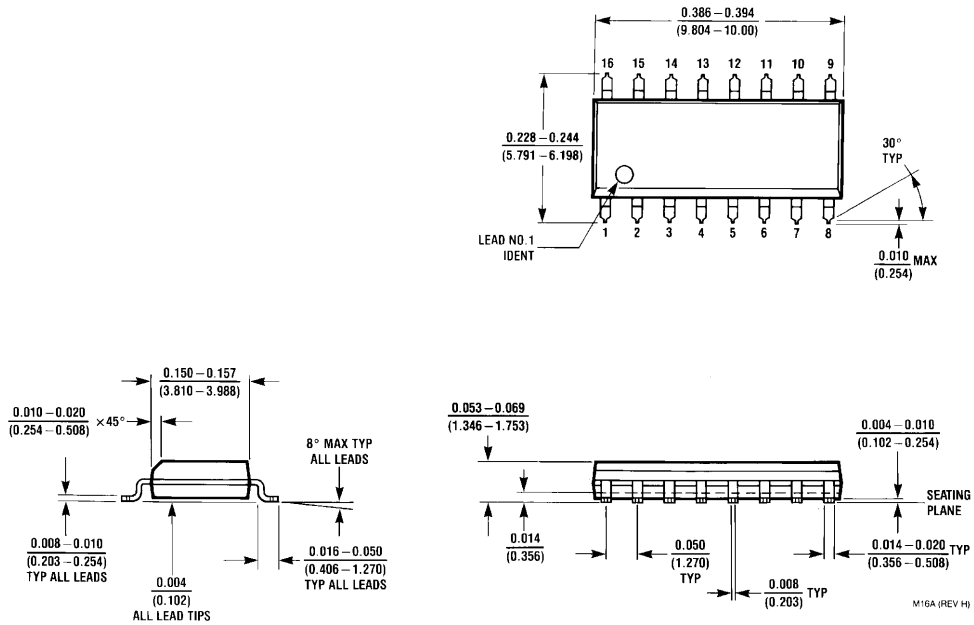

16-Pin SOIC
Order Number LMH0024MA
NS Package Number M16A

Notes

For more National Semiconductor product information and proven design tools, visit the following Web sites at:

Products		Design Support	
Amplifiers	www.national.com/amplifiers	WEBENCH	www.national.com/webench
Audio	www.national.com/audio	Analog University	www.national.com/AU
Clock Conditioners	www.national.com/timing	App Notes	www.national.com/appnotes
Data Converters	www.national.com/adc	Distributors	www.national.com/contacts
Displays	www.national.com/displays	Green Compliance	www.national.com/quality/green
Ethernet	www.national.com/ethernet	Packaging	www.national.com/packaging
Interface	www.national.com/interface	Quality and Reliability	www.national.com/quality
LVDS	www.national.com/lvds	Reference Designs	www.national.com/refdesigns
Power Management	www.national.com/power	Feedback	www.national.com/feedback
Switching Regulators	www.national.com/switchers		
LDOs	www.national.com/lido		
LED Lighting	www.national.com/led		
PowerWise	www.national.com/powerwise		
Serial Digital Interface (SDI)	www.national.com/sdi		
Temperature Sensors	www.national.com/tempsensors		
Wireless (PLL/VCO)	www.national.com/wireless		

THE CONTENTS OF THIS DOCUMENT ARE PROVIDED IN CONNECTION WITH NATIONAL SEMICONDUCTOR CORPORATION ("NATIONAL") PRODUCTS. NATIONAL MAKES NO REPRESENTATIONS OR WARRANTIES WITH RESPECT TO THE ACCURACY OR COMPLETENESS OF THE CONTENTS OF THIS PUBLICATION AND RESERVES THE RIGHT TO MAKE CHANGES TO SPECIFICATIONS AND PRODUCT DESCRIPTIONS AT ANY TIME WITHOUT NOTICE. NO LICENSE, WHETHER EXPRESS, IMPLIED, ARISING BY ESTOPPEL OR OTHERWISE, TO ANY INTELLECTUAL PROPERTY RIGHTS IS GRANTED BY THIS DOCUMENT.

TESTING AND OTHER QUALITY CONTROLS ARE USED TO THE EXTENT NATIONAL DEEMS NECESSARY TO SUPPORT NATIONAL'S PRODUCT WARRANTY. EXCEPT WHERE MANDATED BY GOVERNMENT REQUIREMENTS, TESTING OF ALL PARAMETERS OF EACH PRODUCT IS NOT NECESSARILY PERFORMED. NATIONAL ASSUMES NO LIABILITY FOR APPLICATIONS ASSISTANCE OR BUYER PRODUCT DESIGN. BUYERS ARE RESPONSIBLE FOR THEIR PRODUCTS AND APPLICATIONS USING NATIONAL COMPONENTS. PRIOR TO USING OR DISTRIBUTING ANY PRODUCTS THAT INCLUDE NATIONAL COMPONENTS, BUYERS SHOULD PROVIDE ADEQUATE DESIGN, TESTING AND OPERATING SAFEGUARDS.

EXCEPT AS PROVIDED IN NATIONAL'S TERMS AND CONDITIONS OF SALE FOR SUCH PRODUCTS, NATIONAL ASSUMES NO LIABILITY WHATSOEVER, AND NATIONAL DISCLAIMS ANY EXPRESS OR IMPLIED WARRANTY RELATING TO THE SALE AND/OR USE OF NATIONAL PRODUCTS INCLUDING LIABILITY OR WARRANTIES RELATING TO FITNESS FOR A PARTICULAR PURPOSE, MERCHANTABILITY, OR INFRINGEMENT OF ANY PATENT, COPYRIGHT OR OTHER INTELLECTUAL PROPERTY RIGHT.

LIFE SUPPORT POLICY

NATIONAL'S PRODUCTS ARE NOT AUTHORIZED FOR USE AS CRITICAL COMPONENTS IN LIFE SUPPORT DEVICES OR SYSTEMS WITHOUT THE EXPRESS PRIOR WRITTEN APPROVAL OF THE CHIEF EXECUTIVE OFFICER AND GENERAL COUNSEL OF NATIONAL SEMICONDUCTOR CORPORATION. As used herein:

Life support devices or systems are devices which (a) are intended for surgical implant into the body, or (b) support or sustain life and whose failure to perform when properly used in accordance with instructions for use provided in the labeling can be reasonably expected to result in a significant injury to the user. A critical component is any component in a life support device or system whose failure to perform can be reasonably expected to cause the failure of the life support device or system or to affect its safety or effectiveness.

National Semiconductor and the National Semiconductor logo are registered trademarks of National Semiconductor Corporation. All other brand or product names may be trademarks or registered trademarks of their respective holders.

Copyright© 2008 National Semiconductor Corporation

For the most current product information visit us at www.national.com



**National Semiconductor
Americas Technical
Support Center**
Email:
new.feedback@nsc.com
Tel: 1-800-272-9959

**National Semiconductor Europe
Technical Support Center**
Email: europe.support@nsc.com
German Tel: +49 (0) 180 5010 771
English Tel: +44 (0) 870 850 4288

**National Semiconductor Asia
Pacific Technical Support Center**
Email: ap.support@nsc.com

**National Semiconductor Japan
Technical Support Center**
Email: jpn.feedback@nsc.com