

LMH0356

3 Gbps HD/SD SDI Reclocker with 4:1 Input Mux and FR4 EQs

General Description

The LMH0356 3 Gbps HD/SD SDI Reclocker with 4:1 Input Mux and FR4 EQs retimes serial digital video data conforming to the SMPTE 424M, SMPTE 292M, and SMPTE 259M (C) standards. The LMH0356 operates at serial data rates of 270 Mbps, 1.483 Gbps, 1.485 Gbps, 2.967 Gbps, and 2.97 Gbps. The LMH0356 supports DVB-ASI operation at 270 Mbps. The LMH0356 includes an integrated 4:1 input multiplexer for selecting one of four input data streams for retiming. In addition, the four inputs of the LMH0356 each have an FR4 equalizer capable of equalizing 0-30" of FR4 trace length.

The LMH0356 automatically detects the incoming data rate and adjusts itself to retime the incoming data to suppress accumulated jitter. The LMH0356 recovers the serial data-rate clock and optionally provides it as an output. The LMH0356 has two differential serial data outputs; the second output may be selected as a low-jitter, data-rate clock output. Controls and indicators are: serial clock or second serial data output select, manual rate select input, SD/HD rate indicator output, lock detect output, auto/manual data bypass, output mute, and device enable. The serial data inputs, outputs, and serial clock outputs are differential LVPECL compatible. The CML serial data and serial clock outputs are suitable for driving 100Ω differentially terminated networks. The control logic inputs and outputs are LVCMOS compatible.

The LMH0356 is powered from a single 3.3V supply. Power dissipation is typically 430 mW. The device is housed in a 48-pin LLP (also known as QFN) package.

Features

- Supports SMPTE 424M, SMPTE 292M, and SMPTE 259M (C) serial digital video standards
- Supports 270 Mbps, 1.483 Gbps, 1.485 Gbps, 2.967 Gbps, and 2.97 Gbps serial data rate operation
- Supports DVB-ASI at 270 Mbps
- Single 3.3V supply operation
- 430 mW typical power consumption
- Integrated 4:1 multiplexed input
- 0-30" FR4 equalizer on each multiplexed input
- Two differential, reclocked outputs
- Choice of second reclocked output or recovered clock output
- Single 27 MHz external crystal or reference clock input
- Manual rate select input
- SD/HD operating rate indicator output
- Lock Detect indicator output
- Output mute function for data and clock
- Auto/Manual reclocker bypass
- Power saver mode with device power down control (10 mW typical power consumption in disabled state)
- Differential LVPECL compatible serial data inputs and outputs
- LVCMOS control inputs and indicator outputs
- 48-Pin LLP package
- Industrial temperature range: -40°C to +85°C
- Footprint compatible with the LMH0056 and LMH0036

Applications

- SDTV/HDTV and 3 Gbps serial digital video interfaces for:
 - Digital video routers and switchers
 - Digital video processing and editing equipment
 - DVB-ASI equipment
 - Video standards and format converters

2.97 Gbps Signal Before FR4 Equalization (0.6 UI Jitter)

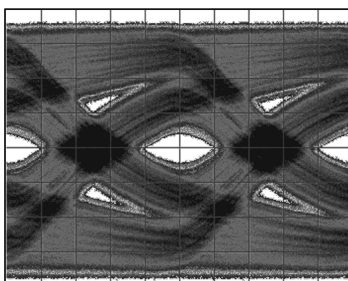

30016710

2.97 Gbps Signal After FR4 Equalization (0.23 UI Jitter)

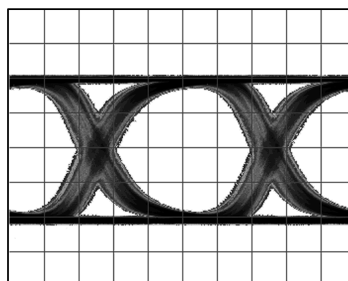

30016711

2.97 Gbps Signal After Reclocking (0.06 UI Jitter)

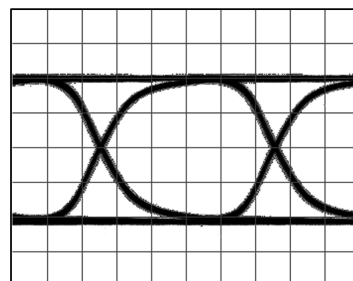

30016712

Typical Application

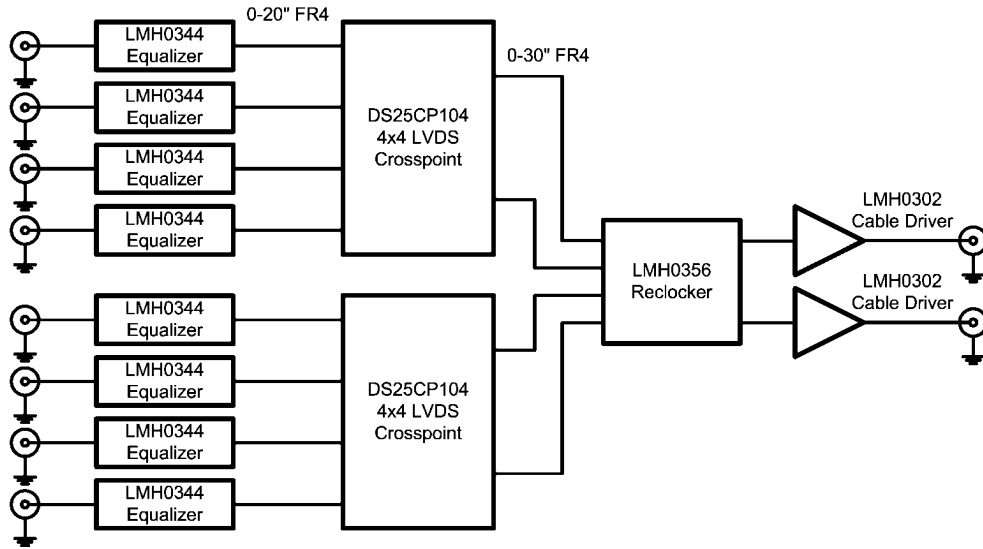

30016701

Block Diagram

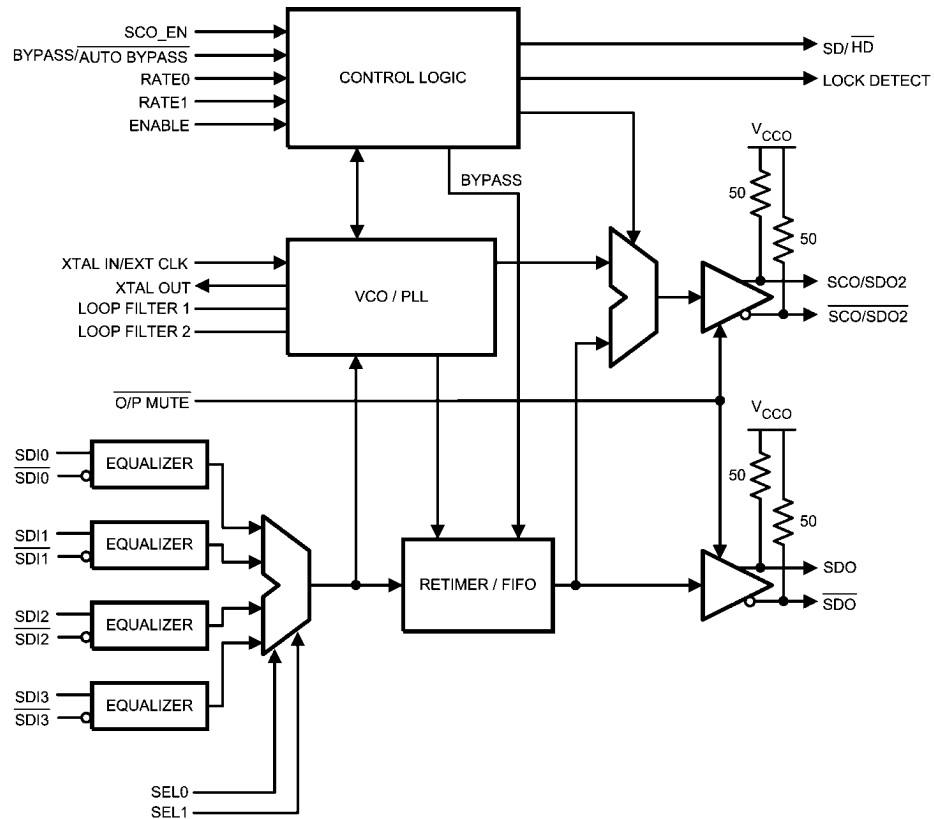

30016703

Pin Descriptions

Pin	Name	Description
1	SDI0	Data Input 0 True.
2	$\overline{\text{SDI0}}$	Data Input 0 Complement.
4	SDI1	Data Input 1 True.
5	$\overline{\text{SDI1}}$	Data Input 1 Complement.
7	SDI2	Data Input 2 True.
8	$\overline{\text{SDI2}}$	Data Input 2 Complement.
9	ENABLE	Device Enable. Powers down device when low. This pin has an internal pullup.
10	SDI3	Data Input 3 True.
11	$\overline{\text{SDI3}}$	Data Input 3 Complement.
15	BYPASS/AUTO BYPASS	Bypass/Auto Bypass mode select. Bypasses reclocking when high. This pin has an internal pulldown.
16	OUTPUT MUTE	Data and Clock Output Mute input. Mutes the output when low. This pin has an internal pullup.
18	XTAL IN/EXT CLK	Crystal or External Oscillator input.
22	XTAL OUT	Crystal Oscillator output.
24	LOCK DETECT	PLL Lock Detect output (active high).
28	$\overline{\text{SCO/SDO2}}$	Serial Clock or Serial Data Output 2 Complement.
29	SCO/SDO2	Serial Clock or Serial Data Output 2 True.
32	$\overline{\text{SDO}}$	Data Output Complement.
33	SDO	Data Output True.
36	SD/HD	Data Rate Range output. Output is high for SD and low for HD or 3G.
37	SCO_EN	Serial Clock or Serial Data 2 Output select. Sets second output to output the clock when high and the data when low. This pin has an internal pulldown.
43	LF1	Loop Filter.
44	LF2	Loop Filter.
45	RATE0	Data Rate select input. This pin has an internal pulldown.
46	RATE1	Data Rate select input. This pin has an internal pulldown.
47	SELO	Data Input select input. This pin has an internal pulldown.
48	SEL1	Data Input select input. This pin has an internal pulldown.
3, 6, 12, 14, 30, 31, 34, 35,	V_{CC}	Positive power supply input.
DAP, 13, 17, 19, 20, 21, 23, 25, 26, 27, 38, 39, 40, 41, 42	V_{EE}	Negative power supply input.

Connection Diagram

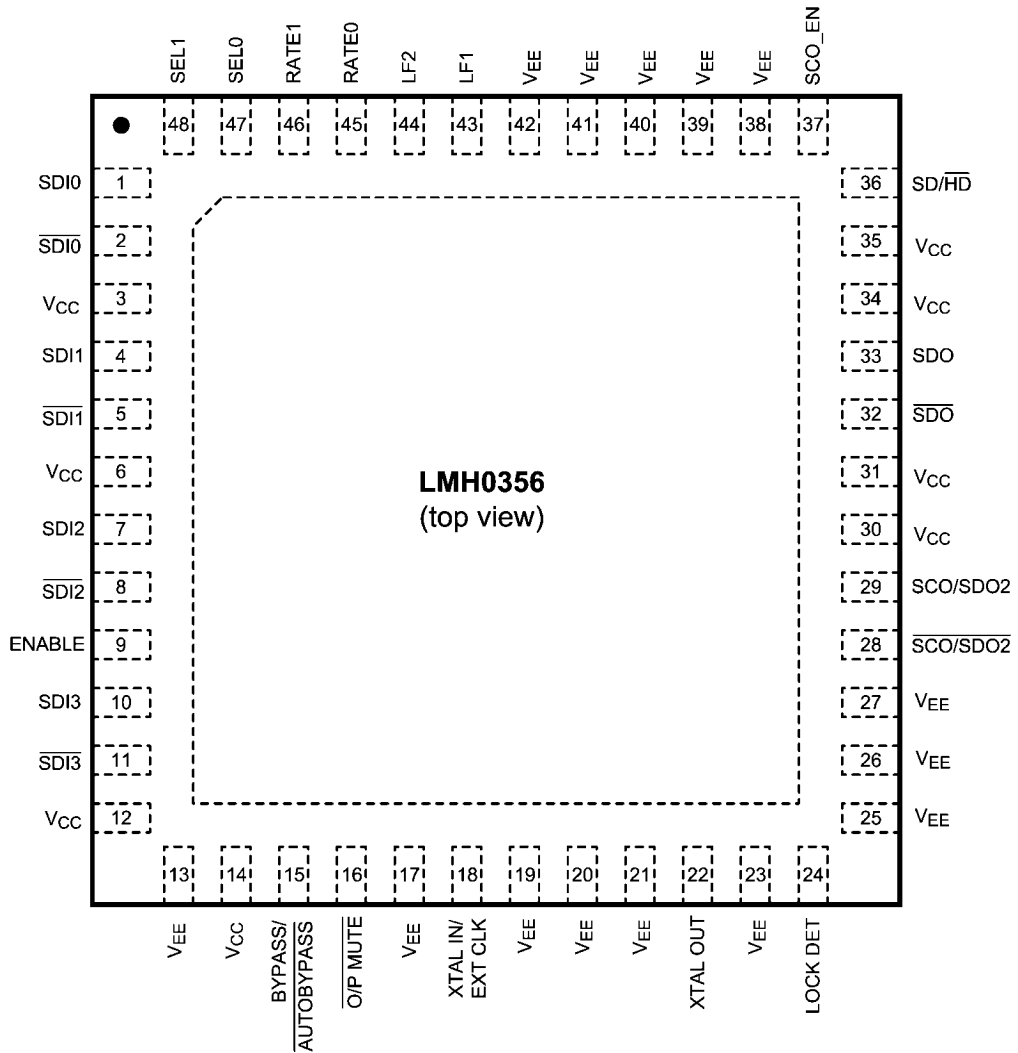

30016702

The exposed die attach pad is the primary negative electrical terminal for this device. It must be connected to the negative power supply voltage.

48-Pin LLP
Order Number LMH0356SQ
See NS Package Number SQA48A

Absolute Maximum Ratings (Note 1)

It is anticipated that this device will not be offered in a military qualified version. If Military/Aerospace specified devices are required, please contact the National Semiconductor Sales Office/Distributors for availability and specifications.

Supply Voltage ($V_{CC}-V_{EE}$)	4.0V
Logic Supply Voltage (V_i)	$V_{EE}-0.15V$ to $V_{CC}+0.15V$
Logic Input Current (single input):	
$V_i = V_{EE}-0.15V$	-5 mA
$V_i = V_{CC}+0.15V$	+5 mA
Logic Output Voltage (V_o)	$V_{EE}-0.15V$ to $V_{CC}+0.15V$
Logic Output Source/Sink Current	± 8 mA
Serial Data Input Voltage (V_{SDI})	V_{CC} to $V_{CC}-2.0V$
Serial Data Output Sink Current (I_{SDO})	24 mA
Package Thermal Resistance	
θ_{JA} 48-pin LLP	24°C/W
θ_{JC} 48-pin LLP	1.5°C/W

Storage Temp. Range	-65°C to +150°C
Junction Temperature	+125°C
Lead Temperature (Soldering 4 Sec)	+260°C (Pb-free)
ESD Rating (HBM)	8 kV
ESD Rating (MM)	400V
ESD Rating (CDM)	1250V

Recommended Operating Conditions

Supply Voltage ($V_{CC}-V_{EE}$)	3.3V $\pm 5\%$
Logic Input Voltage	V_{EE} to V_{CC}
Differential Serial Input Voltage	800 mV $\pm 10\%$
Serial Data or Clock Output Sink Current (I_{SO})	16 mA max.
Operating Free Air Temperature (T_A)	-40°C to +85°C

DC Electrical Characteristics

Over Supply Voltage and Operating Temperature ranges, unless otherwise specified. (Notes 2, 3)

Symbol	Parameter	Conditions	Reference	Min	Typ	Max	Units
V_{IH}	Input Voltage High Level		Logic inputs	2		V_{CC}	V
V_{IL}	Input Voltage Low Level			V_{EE}		0.8	V
I_{IH}	Input Current High Level	$V_{IH} = V_{CC}$			47	65	μA
I_{IL}	Input Current Low Level	$V_{IL} = V_{EE}$			-18	-25	μA
V_{OH}	Output Voltage High Level	$I_{OH} = -2$ mA	Logic outputs	2			V
V_{OL}	Output Voltage Low Level	$I_{OL} = +2$ mA				$V_{EE} + 0.6$	V
V_{SDID}	Serial Input Voltage, Differential	(Note 8)	SDI	200		1600	mV _{P-P}
V_{CMI}	Input Common Mode Voltage	$V_{SDID} = 200$ mV, (Note 8)		$V_{EE}+1.2$		$V_{CC}-0.2$	V
V_{SDOD}	Serial Data Output Voltage, Differential	100 Ω differential load	SDO	620	750	880	mV _{P-P}
V_{SCOD}	Serial Clock Output Voltage, Differential	100 Ω differential load, 2970 Mbps, (Note 8)	SCO	400	525	650	mV _{P-P}
V_{CMO}	Output Common Mode Voltage	100 Ω differential load	SDO, SCO		$V_{CC}-V_{SDOD}$		V
I_{CC}	Power Supply Current, 3.3V supply, Total	2970 Mbps, device enabled			130	150	mA
		Device disabled (ENABLE = 0)			3		mA

AC Electrical Characteristics

Over Supply Voltage and Operating Temperature ranges, unless otherwise specified. (Note 3)

Symbol	Parameter	Conditions	Reference	Min	Typ	Max	Units
BR _{SD}	Serial Data Rate	SMPTE 259M, C	SDI, SDO		270		Mbps
BR _{SD}	Serial Data Rate	SMPTE 292M			1483, 1485		Mbps
BR _{SD}	Serial Data Rate	SMPTE 424M			2967, 2970		Mbps
TOL _{JIT}	Serial Input Jitter Tolerance	270 Mbps, (Notes 7, 8, 9)	SDI	>6			UI _{P-P}
TOL _{JIT}	Serial Input Jitter Tolerance	270 Mbps, (Notes 7, 8, 10)		>0.6			UI _{P-P}
TOL _{JIT}	Serial Input Jitter Tolerance	1483 or 1485 Mbps, (Notes 7, 8, 9)		>6			UI _{P-P}
TOL _{JIT}	Serial Input Jitter Tolerance	1483 or 1485 Mbps, (Notes 7, 8, 10)		>0.6			UI _{P-P}
TOL _{JIT}	Serial Input Jitter Tolerance	2967 or 2970 Mbps, (Notes 7, 8, 9)		>6			UI _{P-P}
TOL _{JIT}	Serial Input Jitter Tolerance	2967 or 2970 Mbps, (Notes 7, 8, 10)		>0.6			UI _{P-P}
t _{JIT}	Serial Data Output Jitter	270 Mbps, (Notes 8, 11)	SDO		0.01	0.03	UI _{P-P}
t _{JIT}	Serial Data Output Jitter	1483 or 1485 Mbps, (Notes 8, 12)			0.04	0.05	UI _{P-P}
t _{JIT}	Serial Data Output Jitter	2967 or 2970 Mbps, (Notes 8, 13)			0.08	0.09	UI _{P-P}
BW _{LOOP}	Loop Bandwidth	270 Mbps, <0.1dB Peaking			275		kHz
		1485 Mbps, <0.1dB Peaking			1.5		MHz
		2970 Mbps, <0.1dB Peaking			2.75		MHz
F _{CO}	Serial Clock Output Frequency	270 Mbps data rate	SCO		270		MHz
F _{CO}	Serial Clock Output Frequency	1483 Mbps data rate			1483		MHz
F _{CO}	Serial Clock Output Frequency	1485 Mbps data rate			1485		MHz
F _{CO}	Serial Clock Output Frequency	2967 Mbps data rate			2967		MHz
F _{CO}	Serial Clock Output Frequency	2970 Mbps data rate			2970		MHz
t _{JIT}	Serial Clock Output Jitter				2	3	ps _{RMS}
	Serial Clock Output Alignment with respect to Data Interval	(Note 8)	SDO, SCO	40		60	%
	Serial Clock Output Duty Cycle	(Note 8)	SCO	45		55	%
T _{ACQ}	Acquisition Time	(Note 6)				15	ms
t _r , t _f	Input rise/fall time	10%–90%	Logic inputs		1.5		ns

Symbol	Parameter	Conditions	Reference	Min	Typ	Max	Units
t_r, t_f	Input rise/fall time	20%–80%, 270 Mbps, (Note 4)	SDI			1500	ps
t_r, t_f	Input rise/fall time	20%–80%, 1483 or 1485 Mbps, (Note 4)				270	ps
t_r, t_f	Input rise/fall time	20%–80%, 2967 or 2970 Mbps, (Note 4)				135	ps
t_r, t_f	Output rise/fall time	10%–90%	Logic outputs		1.5		ns
t_r, t_f	Output rise/fall time	20%–80%, (Notes 5, 8)	SDO, SCO		90	130	ps
F_{REF}	Reference Clock Frequency				27		MHz
F_{TOL}	Reference Clock Frequency Tolerance				± 50		ppm

Note 1: “Absolute Maximum Ratings” are those parameter values beyond which the life and operation of the device cannot be guaranteed. The stating herein of these maximums shall not be construed to imply that the device can or should be operated at or beyond these values. The table of “Electrical Characteristics” specifies acceptable device operating conditions.

Note 2: Current flow into device pins is defined as positive. Current flow out of device pins is defined as negative. All voltages are referenced to V_{EE} (equal to zero volts).

Note 3: Typical values are stated for: $V_{CC} = +3.3V$, $T_A = +25^\circ C$.

Note 4: This specification is guaranteed by design.

Note 5: $R_L = 100\Omega$ differential.

Note 6: Measured from first SDI transition until Lock Detect (LD) output goes high (true).

Note 7: Peak-to-peak amplitude with sinusoidal modulation per SMPTE RP 184-1996 paragraph 4.1. The test data signal shall be color bars.

Note 8: This parameter is guaranteed by characterization over voltage and temperature limits.

Note 9: Refer to “A1” in Figure 1 of SMPTE RP 184-1996.

Note 10: Refer to “A2” in Figure 1 of SMPTE RP 184-1996.

Note 11: PRBS $2^{10}-1$, input jitter = 31 ps_{p-p}.

Note 12: PRBS $2^{10}-1$, input jitter = 24 ps_{p-p}.

Note 13: PRBS $2^{10}-1$, input jitter = 22 ps_{p-p}.

Device Description

The LMH0356 3 Gbps HD/SD SDI Reclocker with 4:1 Input Mux and FR4 EQs is used in many types of digital video signal processing equipment. Supported serial digital video standards are SMPTE 259M (C), SMPTE 292M, and SMPTE 424M. Corresponding serial data rates are 270 Mbps, 1.483 Gbps, 1.485 Gbps, 2.967 Gbps, and 2.97 Gbps. DVB-ASI data at 270 Mbps may also be retimed. The LMH0356 retimes the serial data stream to suppress accumulated jitter. It provides two low-jitter, differential, serial data outputs. The second output may be selected to output either serial data or a low-jitter serial data-rate clock. Controls and indicators are: serial clock or second serial data output select, manual rate select input, SD/HD rate output, lock detect output, auto/manual data bypass and output mute.

Serial data inputs are CML and LVPECL compatible. Serial data and clock outputs are differential CML and produce LVPECL compatible levels. The output buffer design can drive AC or DC-coupled, terminated 100 Ω differential loads. The differential output level is 750 mV_{P-P} into 100 Ω AC or DC-coupled differential loads. Logic inputs and outputs are LVC-MOS compatible.

The device package is a 48-pin LLP with an exposed die attach pad. The exposed die attach pad is electrically connected to device ground (V_{EE}) and is the primary electrical terminal for the device. This terminal must be connected to the negative power supply or circuit ground.

Serial Data Inputs, Serial Data and Clock Outputs

SERIAL DATA INPUT AND OUTPUTS

The differential serial data inputs, SDI0-SDI3, accept serial digital video data at the rates specified in *Table 1*. *Figure 1* shows the equivalent input circuit for SDI[3:0] and $\overline{\text{SDI}}[3:0]$. The serial data inputs are differential LVPECL compatible.

These inputs have 50 Ω internal terminations (100 Ω differential) with an internal bias as shown in *Figure 1*. These inputs are intended to be DC coupled to devices such as the LMH0344 adaptive cable equalizer. DC-coupled inputs must be kept within the specified common mode range. The inputs may be AC coupled if the input signal is outside the LMH0356's input common mode range (such as when interfacing to 5V PECL), and in that case the bias is supplied internally so no additional input biasing is required. See *Application Information* for more information on input interfacing.

The LMH0356 provides four independent, equalized and multiplexed data inputs. The active input channel is selected via the SEL0 and SEL1 pins, as shown in *Table 2*. The equalizer on each of the four inputs is capable of equalizing up to 30" of FR4 trace without the need for programming for different trace lengths or data rates.

The LMH0356 has two, retimed, differential, serial data outputs, SDO and SCO/SDO2. These outputs provide low jitter, differential, retimed data to devices such as the LMH0302 cable driver or the LMH0031 deserializer. Output SCO/SDO2 is multiplexed and can provide either a second serial data output or a serial clock output. *Figure 2* shows the equivalent output circuit for SDO, $\overline{\text{SDO}}$, SCO/SDO2, and $\overline{\text{SCO/SDO2}}$.

The SCO_EN input controls the operating mode for the SCO/SDO2 output. When the SCO_EN input is high the SCO/SDO2 output provides a serial clock. When SCO_EN is low, the SCO/SDO2 output provides retimed serial data.

Both differential serial data outputs, SDO and SCO/SDO2, are muted when the OUTPUT MUTE input is a logic low level. SCO/SDO2 also mutes when the Bypass mode is activated when this output is operating as the serial clock output. When muted, SDO and $\overline{\text{SDO}}$ (or SDO2 and $\overline{\text{SDO2}}$) will assume opposite differential output levels. The CML serial data outputs are differential LVPECL compatible. These outputs have internal 50 Ω pull-ups and are suitable for driving AC or DC-coupled, 100 Ω center-tapped, AC grounded or 100 Ω uncenter-tapped, differentially terminated networks.

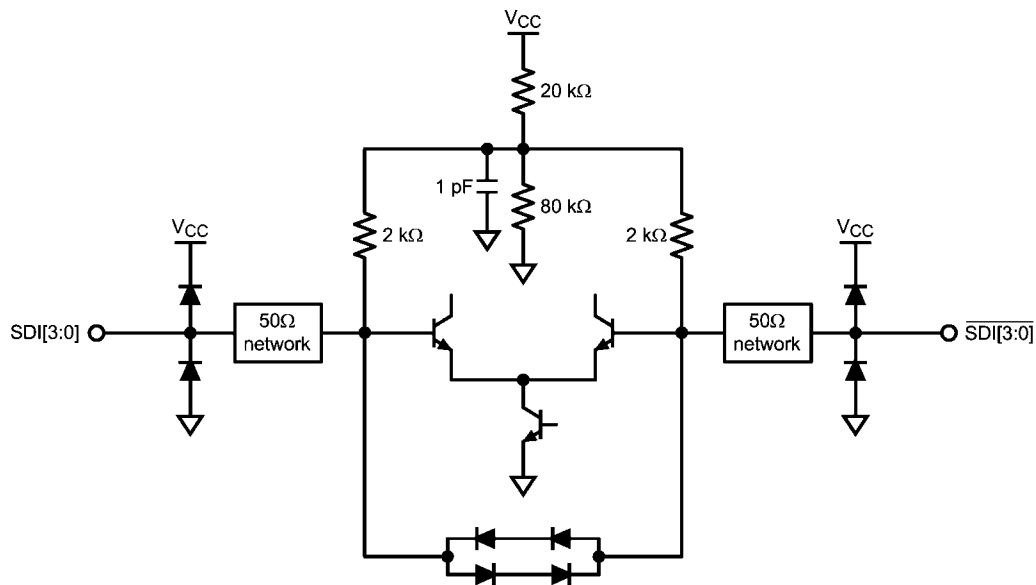

30016708

FIGURE 1. Equivalent SDI Input Circuit (SDI[3:0], $\overline{\text{SDI}}[3:0]$)

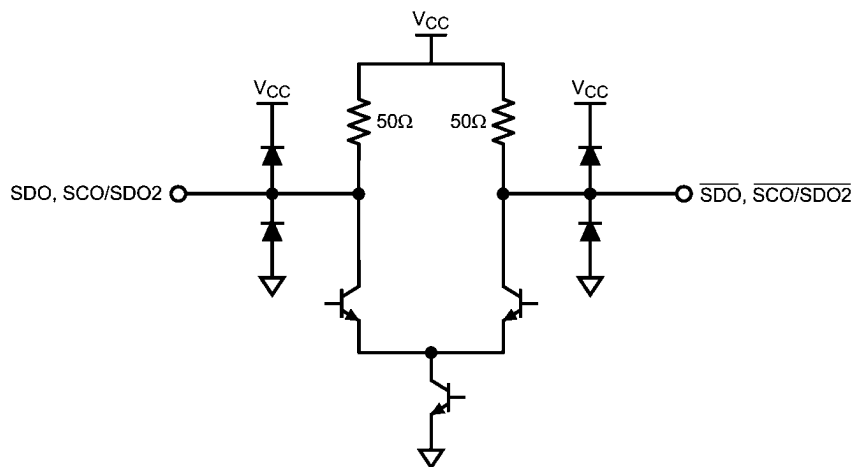

30016709

FIGURE 2. Equivalent SDO Output Circuit (SDO, $\overline{\text{SDO}}$, SCO/SDO2, $\overline{\text{SCO/SDO2}}$)

OPERATING SERIAL DATA RATES

This device operates at serial data rates of 270 Mbps, 1483 Mbps, 1485 Mbps, 2967 Mbps, and 2970 Mbps. The device does not lock to harmonics of these rates. The device does not lock and automatically enters the reclocker bypass mode for the following data rates: 143 Mbps, 177 Mbps, 360 Mbps, and 540 Mbps.

SERIAL DATA CLOCK/SERIAL DATA 2 OUTPUT

The Serial Data Clock/Serial Data 2 Output is controlled by the SCO_EN input and provides either a second retimed serial data output or a low jitter differential clock output appropriate to the serial data rate being processed. When operating as a serial clock output, the rising edge of the clock will be positioned within the corresponding serial data bit interval within 10% of the center of the data interval.

Differential output SCO/SDO2 functions as the second serial data output when the SCO_EN input is a logic-low level. This output functions as the serial clock output when the SCO_EN input is a logic-high level. The SCO_EN input has an internal pull-down device and the default state of SCO_EN is low (serial data output 2 enabled). SCO/SDO2 is muted when the OUTPUT MUTE input is a logic low level. When the Bypass mode is activated and this output is functioning as a serial clock output, the output will also be muted. If an unsupported data rate is used while in Auto Bypass mode with this output functioning as a serial clock output, the output is invalid.

Control Inputs and Indicator Outputs

SERIAL DATA RATE SELECTOR

The Serial Data Rate Selector (RATE [1:0]) permits the user to fix the operating serial data rate. The pins have internal pull-

downs which maintain a logic-low input condition unless externally driven to a logic-high condition. This input also serves to place the device in a test mode. The codes shown in *Table 1* select the desired operating serial data rate. The LMH0356 then enters either the Auto-Rate Detect mode or a single operating rate. Selecting the 270 Mbps rate mode may also be used when reclocking DVB-ASI data. DVB-ASI data is MPEG2 coded data that is transmitted in 8B10B coding. The device will reclock this data without harmonic locking.

TABLE 1. Data Rate Select Input Codes

RATE [1:0] Code	Data Rate or Mode	Comments
00	Auto-Rate Detect mode	
01	270 Mbps	May be used to support DVB-ASI operation
10	1483/1485 Mbps, 2967/2970 Mbps	

SERIAL DATA INPUT SELECTOR

The Serial Data Input Selector (SEL [1:0]) allows the user to select the active input channel. *Table 2* shows the input selected for a given state of SEL [1:0]. The SEL pins have internal pull-downs.

TABLE 2. Data Input Select Codes

SEL [1:0] Code	Selected Input
00	SDI0
01	SDI1
10	SDI2
11	SDI3

LOCK DETECT

The Lock Detect (LD) output, when high, indicates that data is being received and the PLL is locked. LD may be connected to the OUTPUT MUTE input to mute the data and clock outputs when no data signal is being received. See *Table 3*.

OUTPUT MUTE

The OUTPUT MUTE input, when low, mutes the serial data and clock outputs. It may be connected to Lock Detect or externally driven to mute or un-mute the outputs. If OUTPUT MUTE is connected to LD, then the data and clock outputs are muted when the PLL is not locked. This function overrides the Bypass function: see *Table 3*. OUTPUT MUTE has an internal pull-up device to enable the output by default.

BYPASS/AUTO BYPASS

The Bypass/Auto Bypass input, when high, forces the device to output the data without reclocking it. When this input is low, the device automatically bypasses the reclocking function when the device is in an unlocked condition or the detected data rate is a rate which the device does not support. See *Table 3*. BYPASS/AUTO BYPASS has an internal pull-down device.

TABLE 3. Control Functionality

LOCK DETECT	OUTPUT MUTE	BYPASS/AUTO BYPASS	DEVICE STATUS
0	1	0	PLL unlocked, reclocker bypassed
1	1	0	PLL locked to supported data rate, reclocker not bypassed
X	0	X	Outputs muted
0	LOCK DETECT	X	Outputs muted
1	LOCK DETECT	0	PLL locked to supported data rate, reclocker not bypassed
1	LOCK DETECT	1	PLL locked to supported data rate, reclocker bypassed
X	1	1	Outputs not muted, reclocker bypassed

SD/ $\overline{\text{HD}}$

The SD/ $\overline{\text{HD}}$ output indicates whether the LMH0356 is processing SD or HD / 3 Gbps data rates. It may be used to control another device such as the LMH0302 cable driver. When this output is high it indicates that the data rate is 270 Mbps. When low, the indicated data rate is 1483, 1485, 2967, or 2970 Mbps. The SD/ $\overline{\text{HD}}$ output is a registered function and

is only valid when the PLL is locked and the Lock Detect output is high. When the PLL is not locked (the Lock Detect output is low), the SD/ $\overline{\text{HD}}$ output defaults to HD (low). The SD/ $\overline{\text{HD}}$ output is undefined for a short time after lock detect assertion or de-assertion due to a data rate change on SDI. See *Figure 3* for a timing diagram showing the relationship between SDI, Lock Detect, and SD/ $\overline{\text{HD}}$.

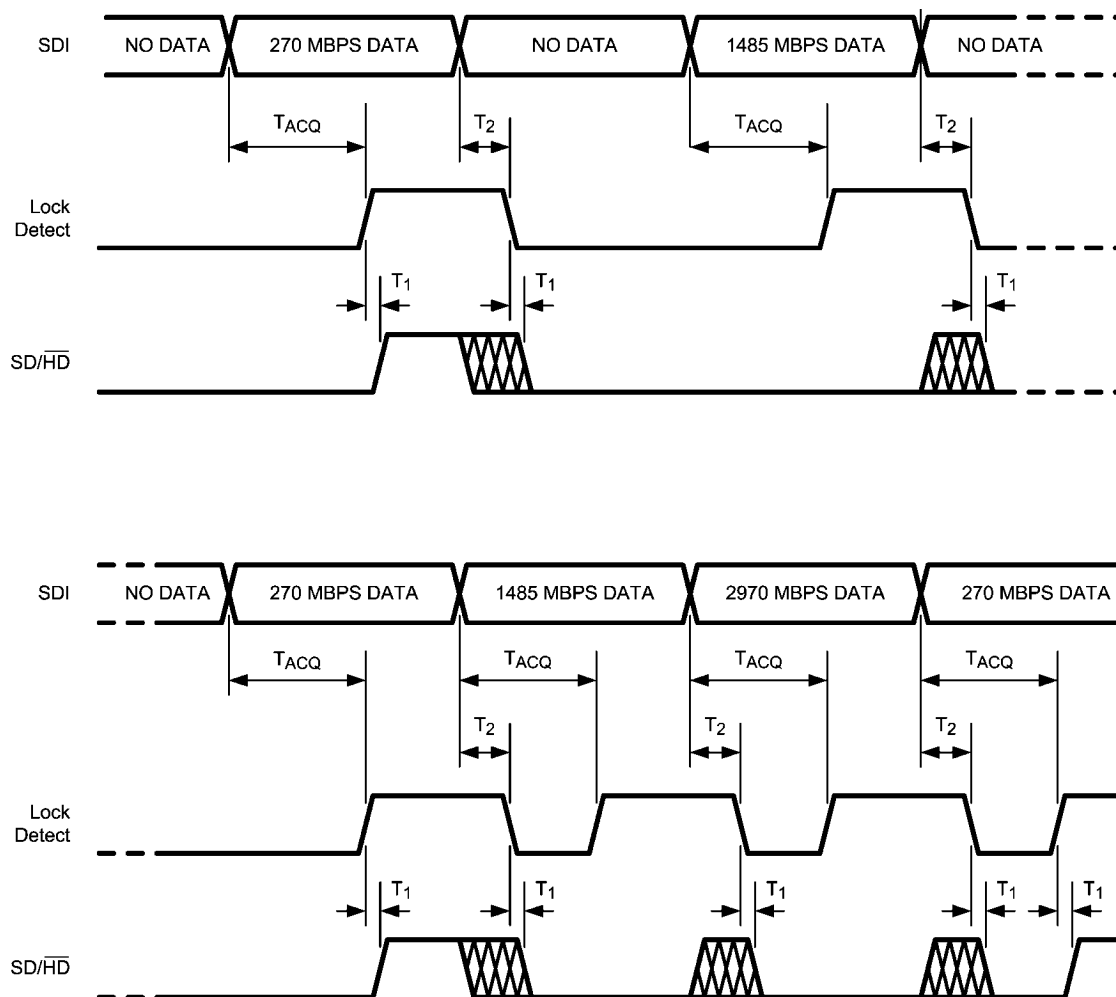

T_{ACQ} = Acquisition Time, defined in the AC Electrical Characteristics Table

T_1 = Time from Lock Detect assertion or deassertion until SD/ $\overline{\text{HD}}$ output is valid, typically 37 ns (one 27 MHz clock period)

T_2 = Time from SDI input change until Lock Detect de-assertion, 1 ms maximum. SD/ $\overline{\text{HD}}$ output is not valid during this time.

30016705

FIGURE 3. SDI, Lock Detect, and SD/ $\overline{\text{HD}}$ Timing

SCO_EN

Input SCO_EN enables the SCO/SDO2 differential output to function either as a serial clock or second serial data output. SCO/SDO2 functions as a serial clock when SCO_EN is high. This pin has an internal pull-down device. The default state (low) enables the SCO/SDO2 output as a second serial data output.

ENABLE

The ENABLE pin is used to enable or disable the LMH0356. When the device is disabled, the output drivers and most of the internal circuitry are powered down. The crystal oscillator / external clock reference circuitry (XTAL IN and XTAL OUT) remain active regardless of the state of ENABLE, allowing the 27 MHz reference clock signal to be generated and passed on to additional reclockers. The ENABLE pin is active high and has an internal pull-up device to enable the LMH0356 by default.

CRYSTAL OR EXTERNAL CLOCK REFERENCE

The LMH0356 uses a 27 MHz crystal or external clock signal as a timing reference input. A 27 MHz parallel resonant crystal and load network may be connected to the XTAL IN/EXT CLK

and XTAL OUT pins. Alternatively, a 27 MHz LVCMOS compatible clock signal may be input to XTAL IN/EXT CLK. Parameters for a suitable crystal are given in *Table 4*.

TABLE 4. Crystal Parameters

Parameter	Value
Frequency	27 MHz
Frequency Stability	±50 ppm @ recommended drive level
Operating Mode	Fundamental mode, Parallel Resonant
Load Capacitance	20 pF
Shunt Capacitance	7 pF
Series Resistance	40Ω max.
Recommended Drive Level	100 μW
Maximum Drive Level	500 μW
Operating Temperature Range	-10°C to +60°C

Application Information

Figure 4 shows a typical application circuit for the LMH0356.

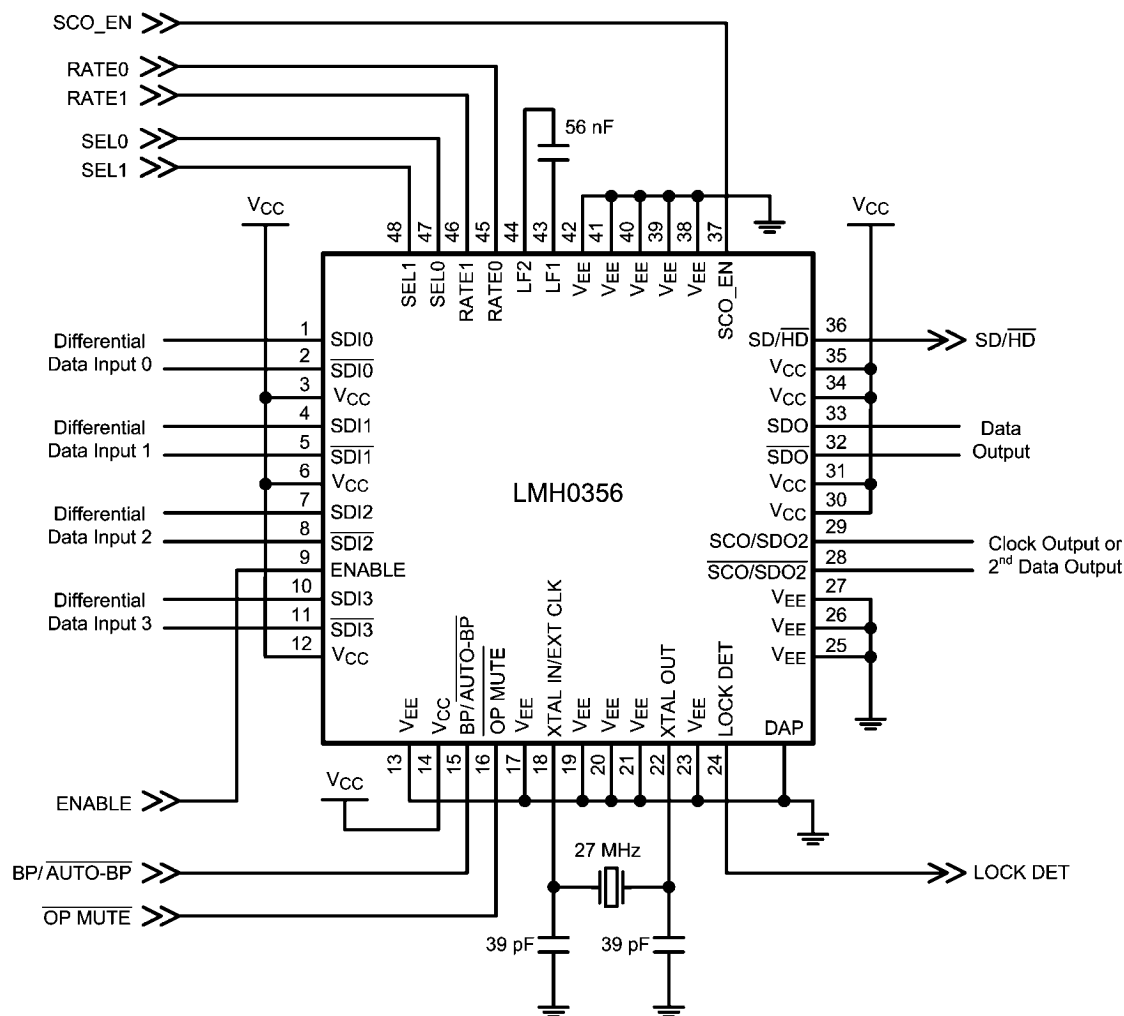

30016704

FIGURE 4. Application Circuit

ENABLE has an internal pullup to enable the device by default. This pin may be pulled low to put the LMH0356 into a powered down mode.

BP/AUTO-BP has an internal pulldown to enable Auto Bypass mode by default. This pin may be pulled high to force the LMH0356 to bypass all data.

OP MUTE has an internal pullup to enable the outputs by default. This pin may be pulled low to mute the outputs.

The XTAL IN/EXT CLK and XTAL OUT pins are shown with a 27 MHz crystal and the proper loading. The crystal should match the parameters described in *Table 4*. Alternately, a 27MHz LVCMOS compatible clock signal may be input to XTAL IN/EXT CLK.

The active high LOCK DETECT output provides an indication that proper data is being received and the PLL is locked.

The SD/HD output may be used to drive the SD/HD pin of an SDI cable driver (such as the LMH0302) in order to properly set the cable driver's edge rate for SMPTE compliance. It defaults to HD/3G (low) when the LMH0356 is not locked.

SCO_EN has an internal pulldown to set the second output (SCO/SDO2) to output data. This pin may be pulled high to set the second output as a serial clock.

The external loop filter capacitor (between LF1 and LF2) should be 56 nF. This is the only supported value; the loop filter capacitor should not be changed.

RATE0 and RATE1 have internal pulldowns to select Auto-Rate Detect mode by default. These pins may also be used to set the device to SD mode or HD/3G mode.

SEL0 and SEL1 have internal pulldowns to select the SDI0 input by default.

The inputs are LVPECL compatible. The LMH0356 has a wide input common mode range and in most cases the input should be DC coupled. For DC coupling, the inputs must be kept within the common mode range specified in *DC Electrical Characteristics*.

Figure 5 shows an example of a DC coupled interface between the LMH0344 cable equalizer and the LMH0356. The LMH0344 output common mode voltage and voltage swing are within the range of the input common mode voltage and

voltage swing of the LMH0356. In this figure, the LMH0344 cable equalizer restores the signal after the coaxial cable. The LMH0356 FR4 equalizer restores the signal after the loss due to the FR4 trace. The LMH0356 inputs have 50Ω internal terminations (100Ω differential) to terminate the transmission line, so no additional components are required.

The outputs are LVPECL compatible. SDO is the primary data output and SCO/SDO2 is a second output that may be set as the serial clock or a second data output. Both outputs are always active. The LMH0356 output should be DC coupled to the input of the receiving device as long as the common mode ranges of both devices are compatible.

Figure 6 shows an example of a DC coupled interface between the LMH0356 and LMH0302 cable driver. All that is required is a 100Ω differential termination as shown. The resistor should be placed as close to the LMH0302 input as possible. If desired, this network may be terminated with two 50Ω resistors and a center tap capacitor to ground in place of the single 100Ω resistor.

The LMH0356 has multiple ground connections, however; the primary ground connection is through the large exposed DAP. The DAP must be connected to ground for proper operation of the LMH0356.

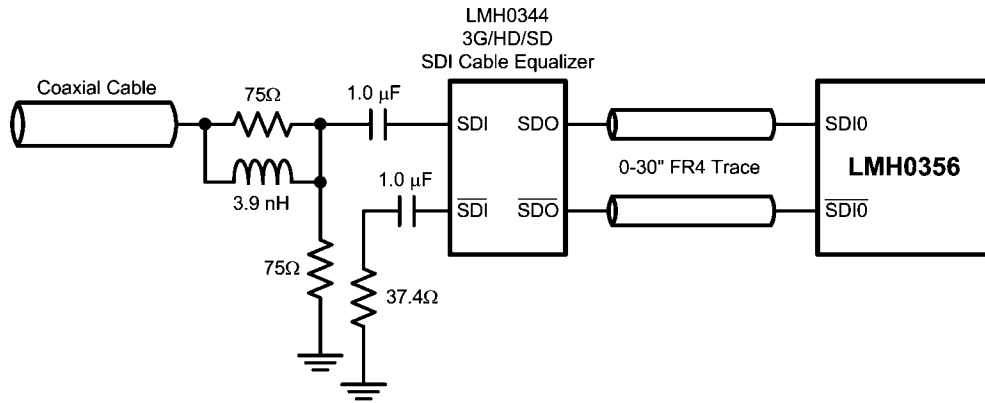

30016706

FIGURE 5. DC Input Interface

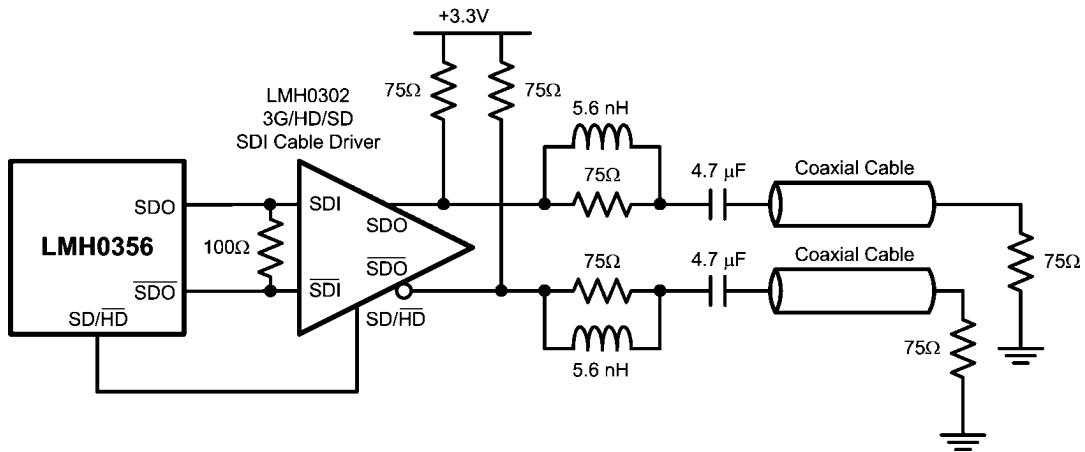

30016707

FIGURE 6. DC Output Interface

Physical Dimensions inches (millimeters) unless otherwise noted

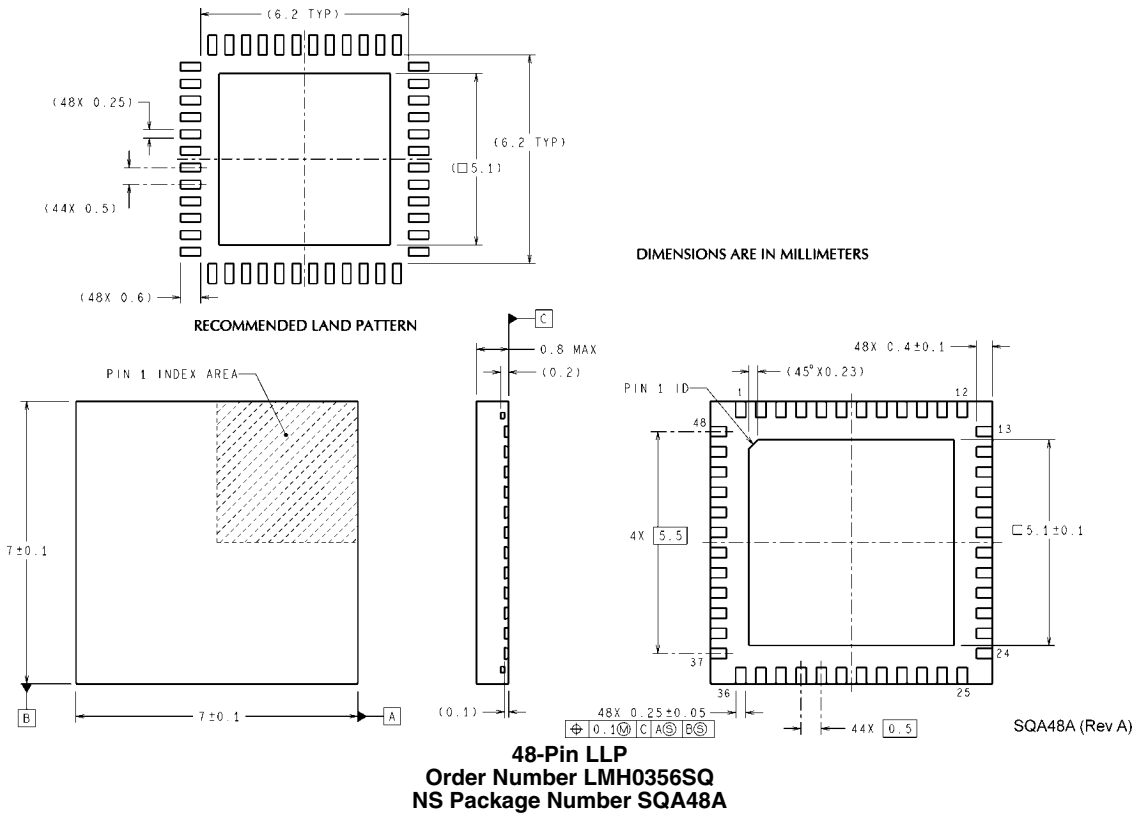

Notes

For more National Semiconductor product information and proven design tools, visit the following Web sites at:

Products		Design Support	
Amplifiers	www.national.com/amplifiers	WEBENCH	www.national.com/webench
Audio	www.national.com/audio	Analog University	www.national.com/AU
Clock Conditioners	www.national.com/timing	App Notes	www.national.com/appnotes
Data Converters	www.national.com/adc	Distributors	www.national.com/contacts
Displays	www.national.com/displays	Green Compliance	www.national.com/quality/green
Ethernet	www.national.com/ethernet	Packaging	www.national.com/packaging
Interface	www.national.com/interface	Quality and Reliability	www.national.com/quality
LVDS	www.national.com/lvds	Reference Designs	www.national.com/refdesigns
Power Management	www.national.com/power	Feedback	www.national.com/feedback
Switching Regulators	www.national.com/switchers		
LDOs	www.national.com/lido		
LED Lighting	www.national.com/led		
PowerWise	www.national.com/powerwise		
Serial Digital Interface (SDI)	www.national.com/sdi		
Temperature Sensors	www.national.com/tempsensors		
Wireless (PLL/VCO)	www.national.com/wireless		

THE CONTENTS OF THIS DOCUMENT ARE PROVIDED IN CONNECTION WITH NATIONAL SEMICONDUCTOR CORPORATION ("NATIONAL") PRODUCTS. NATIONAL MAKES NO REPRESENTATIONS OR WARRANTIES WITH RESPECT TO THE ACCURACY OR COMPLETENESS OF THE CONTENTS OF THIS PUBLICATION AND RESERVES THE RIGHT TO MAKE CHANGES TO SPECIFICATIONS AND PRODUCT DESCRIPTIONS AT ANY TIME WITHOUT NOTICE. NO LICENSE, WHETHER EXPRESS, IMPLIED, ARISING BY ESTOPPEL OR OTHERWISE, TO ANY INTELLECTUAL PROPERTY RIGHTS IS GRANTED BY THIS DOCUMENT.

TESTING AND OTHER QUALITY CONTROLS ARE USED TO THE EXTENT NATIONAL DEEMS NECESSARY TO SUPPORT NATIONAL'S PRODUCT WARRANTY. EXCEPT WHERE MANDATED BY GOVERNMENT REQUIREMENTS, TESTING OF ALL PARAMETERS OF EACH PRODUCT IS NOT NECESSARILY PERFORMED. NATIONAL ASSUMES NO LIABILITY FOR APPLICATIONS ASSISTANCE OR BUYER PRODUCT DESIGN. BUYERS ARE RESPONSIBLE FOR THEIR PRODUCTS AND APPLICATIONS USING NATIONAL COMPONENTS. PRIOR TO USING OR DISTRIBUTING ANY PRODUCTS THAT INCLUDE NATIONAL COMPONENTS, BUYERS SHOULD PROVIDE ADEQUATE DESIGN, TESTING AND OPERATING SAFEGUARDS.

EXCEPT AS PROVIDED IN NATIONAL'S TERMS AND CONDITIONS OF SALE FOR SUCH PRODUCTS, NATIONAL ASSUMES NO LIABILITY WHATSOEVER, AND NATIONAL DISCLAIMS ANY EXPRESS OR IMPLIED WARRANTY RELATING TO THE SALE AND/OR USE OF NATIONAL PRODUCTS INCLUDING LIABILITY OR WARRANTIES RELATING TO FITNESS FOR A PARTICULAR PURPOSE, MERCHANTABILITY, OR INFRINGEMENT OF ANY PATENT, COPYRIGHT OR OTHER INTELLECTUAL PROPERTY RIGHT.

LIFE SUPPORT POLICY

NATIONAL'S PRODUCTS ARE NOT AUTHORIZED FOR USE AS CRITICAL COMPONENTS IN LIFE SUPPORT DEVICES OR SYSTEMS WITHOUT THE EXPRESS PRIOR WRITTEN APPROVAL OF THE CHIEF EXECUTIVE OFFICER AND GENERAL COUNSEL OF NATIONAL SEMICONDUCTOR CORPORATION. As used herein:

Life support devices or systems are devices which (a) are intended for surgical implant into the body, or (b) support or sustain life and whose failure to perform when properly used in accordance with instructions for use provided in the labeling can be reasonably expected to result in a significant injury to the user. A critical component is any component in a life support device or system whose failure to perform can be reasonably expected to cause the failure of the life support device or system or to affect its safety or effectiveness.

National Semiconductor and the National Semiconductor logo are registered trademarks of National Semiconductor Corporation. All other brand or product names may be trademarks or registered trademarks of their respective holders.

Copyright© 2008 National Semiconductor Corporation

For the most current product information visit us at www.national.com



National Semiconductor Americas Technical Support Center
 Email: support@nsc.com
 Tel: 1-800-272-9959

National Semiconductor Europe Technical Support Center
 Email: europe.support@nsc.com
 German Tel: +49 (0) 180 5010 771
 English Tel: +44 (0) 870 850 4288

National Semiconductor Asia Pacific Technical Support Center
 Email: ap.support@nsc.com

National Semiconductor Japan Technical Support Center
 Email: jpn.feedback@nsc.com