

# LMH6715EP

## Enhanced Plastic Dual Wideband Video Op Amp

### General Description

The LMH6715EP combines National's VIP10™ high speed complementary bipolar process with National's current feedback topology to produce a very high speed dual op amp. The LMH6715EP provides 400MHz small signal bandwidth at a gain of +2V/V and 1300V/μs slew rate while consuming only 5.8mA per amplifier from ±5V supplies.

The LMH6715EP offers exceptional video performance with its 0.02% and 0.02° differential gain and phase errors for NTSC and PAL video signals while driving up to four back terminated 75Ω loads. The LMH6715EP also offers a flat gain response of 0.1dB to 100MHz and very low channel-to-channel crosstalk of -70dB at 10MHz. Additionally, each amplifier can deliver 70mA of output current. This level of performance makes the LMH6715EP an ideal dual op amp for high density, broadcast quality video systems.

The LMH6715EP's two very well matched amplifiers support a number of applications such as differential line drivers and receivers. In addition, the LMH6715EP is well suited for Sallen Key active filters in applications such as anti-aliasing filters for high speed A/D converters. Its small 8-pin SOIC package, low power requirement, low noise and distortion allow the LMH6715EP to serve portable RF applications such as IQ channels.

### ENHANCED PLASTIC

- Extended Temperature Performance of -40°C to +85°C
- Baseline Control - Single Fab & Assembly Site
- Process Change Notification (PCN)
- Qualification & Reliability Data
- Solder (PbSn) Lead Finish is standard
- Enhanced Diminishing Manufacturing Sources (DMS) Support

### Features

- $T_A = 25^\circ\text{C}$ ,  $R_L = 100\Omega$ , typical values unless specified.
- Very low diff. gain, phase: 0.02%, 0.02°
- Wide bandwidth: 480MHz ( $A_V = +1V/V$ ); 400MHz ( $A_V = +2V/V$ )
- 0.1dB gain flatness to 100MHz
- Low power: 5.8mA/channel
- -70dB channel-to-channel crosstalk (10MHz)
- Fast slew rate: 1300V/μs
- Unity gain stable
- Improved replacement for CLC412

### Applications

- Selected Military Applications
- Selected Avionics Applications

### Ordering Information

PART NUMBER	VID PART NUMBER	NS PACKAGE NUMBER (Note 3)
LMH6715MAEP	V62/04623-01	M08A
(Notes 1, 2)	TBD	TBD

**Note 1:** For the following (Enhanced Plastic) version, check for availability: LMH6715MAXEP. Parts listed with an "X" are provided in Tape & Reel and parts without an "X" are in Rails.

**Note 2:** FOR ADDITIONAL ORDERING AND PRODUCT INFORMATION, PLEASE VISIT THE ENHANCED PLASTIC WEB SITE AT: [www.national.com/mil](http://www.national.com/mil)

**Note 3:** Refer to package details under Physical Dimensions

### Differential Gain & Phase with Multiple Video Loads

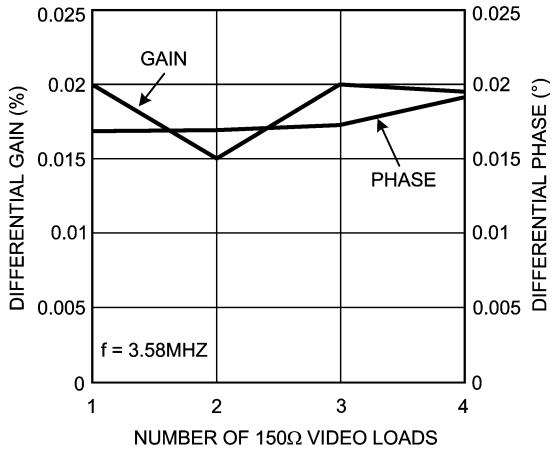

20088508

### Frequency Response vs. $V_{OUT}$

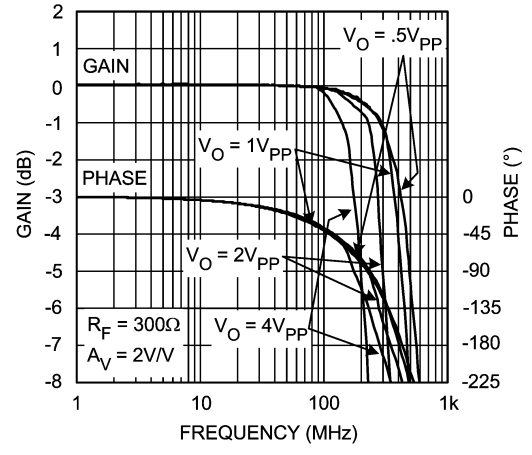

20088516

**Absolute Maximum Ratings** (Note 4)

If Military/Aerospace specified devices are required, please contact the National Semiconductor Sales Office/Distributors for availability and specifications.

ESD Tolerance (Note 7)	
Human Body Model	2000V
Machine Model	150V
$V_{CC}$	$\pm 6.75V$
$I_{OUT}$	(Note 6)
Common-Mode Input Voltage	$\pm V_{CC}$
Differential Input Voltage	2.2V
Maximum Junction Temperature	+150°C

Storage Temperature Range	-65°C to +150°C
Lead Temperature (Soldering 10 sec)	+300°C

**Operating Ratings**

Thermal Resistance		
Package	( $\theta_{JC}$ )	( $\theta_{JA}$ )
SOIC	65°C/W	145°C/W
Operating Temperature Range	-40°C to +85°C	
Nominal Operating Voltage	$\pm 5V$ to $\pm 6V$	

**Electrical Characteristics**

$V_V = +2$ ,  $R_F = 500\Omega$ ,  $V_{CC} = \pm 5V$ ,  $R_L = 100\Omega$ ; unless otherwise specified. **Boldface** limits apply at the temperature extremes.

Symbol	Parameter	Conditions	Min	Typ	Max	Units
<b>Frequency Domain Response</b>						
SSBW	-3dB Bandwidth	$V_{OUT} < 0.5V_{PP}$ , $R_F = 300\Omega$	280	400		MHz
LSBW	-3dB Bandwidth	$V_{OUT} < 4.0V_{PP}$ , $R_F = 300\Omega$		170		MHz
	Gain Flatness	$V_{OUT} < 0.5V_{PP}$				
GFP	Peaking	DC to 100MHz, $R_F = 300\Omega$		0.1		dB
GFR	Rolloff	DC to 100MHz, $R_F = 300\Omega$		0.1		dB
LPD	Linear Phase Deviation	DC to 100MHz, $R_F = 300\Omega$		0.25		deg
DG	Differential Gain	$R_L = 150\Omega$ , 4.43MHz		0.02		%
DP	Differential Phase	$R_L = 150\Omega$ , 4.43MHz		0.02		deg
<b>Time Domain Response</b>						
Tr	Rise and Fall Time	0.5V Step		1.4		ns
		4V Step		3		ns
Ts	Settling Time to 0.05%	2V Step		12		ns
OS	Overshoot	0.5V Step		1		%
SR	Slew Rate	2V Step		1300		V/ $\mu$ s
<b>Distortion And Noise Response</b>						
HD2	2nd Harmonic Distortion	$2V_{PP}$ , 20MHz		-60		dBc
HD3	3rd Harmonic Distortion	$2V_{PP}$ , 20MHz		-75		dBc
	Equivalent Input Noise					
$V_N$	Non-Inverting Voltage	>1MHz		3.4		nV/ $\sqrt{Hz}$
$I_N$	Inverting Current	>1MHz		10.0		pA/ $\sqrt{Hz}$
$I_{NN}$	Non-Inverting Current	>1MHz		1.4		pA/ $\sqrt{Hz}$
SNF	Noise Floor	>1MHz		-153		dB <sub>1Hz</sub>
XTLKA	Crosstalk	Input Referred 10MHz		-70		dB
<b>Static, DC Performance</b>						
$V_{IO}$	Input Offset Voltage			$\pm 2$	$\pm 6$ <b><math>\pm 8</math></b>	mV
$DV_{IO}$	Average Drift			$\pm 30$		$\mu V/^\circ C$
$I_{BN}$	Input Bias Current	Non-Inverting		$\pm 5$	$\pm 12$ <b><math>\pm 20</math></b>	$\mu A$
$DI_{BN}$	Average Drift			$\pm 30$		nA/ $^\circ C$
$I_{BI}$	Input Bias Current	Inverting		$\pm 6$	$\pm 21$ <b><math>\pm 35</math></b>	$\mu A$
$DI_{BI}$	Average Drift			$\pm 20$		nA/ $^\circ C$
PSRR	Power Supply Rejection Ratio	DC	46 <b>44</b>	60		dB

## Electrical Characteristics (Continued)

$A_V = +2$ ,  $R_F = 500\Omega$ ,  $V_{CC} = \pm 5\text{ V}$ ,  $R_L = 100\Omega$ ; unless otherwise specified. **Boldface** limits apply at the temperature extremes.

Symbol	Parameter	Conditions	Min	Typ	Max	Units
CMRR	Common Mode Rejection Ratio	DC	50 <b>47</b>	56		dB
$I_{CC}$	Supply Current per Amplifier	$R_L = \infty$	4.7 <b>4.1</b>	5.8	7.6 <b>8.1</b>	mA

### Miscellaneous Performance

$R_{IN}$	Input Resistance	Non-Inverting		1000		k $\Omega$
$C_{IN}$	Input Capacitance	Non-Inverting		1.0		pF
$R_{OUT}$	Output Resistance	Closed Loop		.06		$\Omega$
$V_O$	Output Voltage Range	$R_L = \infty$		$\pm 4.0$		V
$V_{OL}$		$R_L = 100\Omega$	$\pm 3.5$ <b><math>\pm 3.4</math></b>	$\pm 3.9$		V
CMIR	Input Voltage Range	Common Mode		$\pm 2.2$		V
$I_O$	Output Current			70		mA

**Note 4:** Absolute Maximum Ratings indicate limits beyond which damage to the device may occur. Operating Ratings indicate conditions for which the device is intended to be functional, but specific performance is not guaranteed. For guaranteed specifications, see the Electrical Characteristics tables.

**Note 5:** Electrical Table values apply only for factory testing conditions at the temperature indicated. Factory testing conditions result in very limited self-heating of the device such that  $T_J = T_A$ . No guarantee of parametric performance is indicated in the electrical tables under conditions of internal self heating where  $T_J > T_A$ . See Applications Section for information on temperature de-rating of this device." Min/Max ratings are based on product characterization and simulation. Individual parameters are tested as noted.

**Note 6:** The maximum output current ( $I_{OUT}$ ) is determined by device power dissipation limitations. See the Power Dissipation section of the Application Division for more details.

**Note 7:** Human body model, 1.5k $\Omega$  in series with 100pF. Machine model, 0 $\Omega$  in series with 200pF.

## Connection Diagram

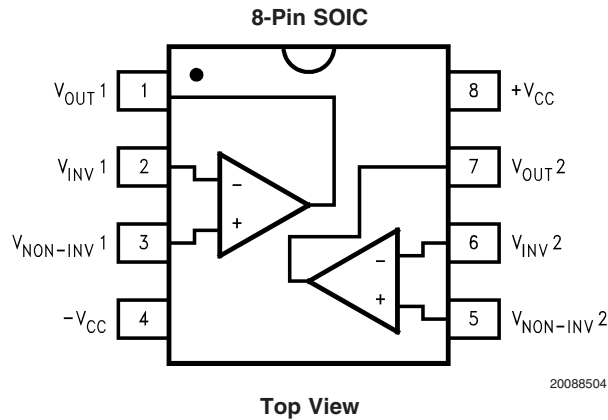

**Typical Performance Characteristics** ( $T_A = 25^\circ\text{C}$ ,  $V_{CC} = \pm 5\text{V}$ ,  $A_V = \pm 2\text{V/V}$ ,  $R_F = 500\Omega$ ,  $R_L = 100\Omega$ , unless otherwise specified).

**Non-Inverting Frequency Response**

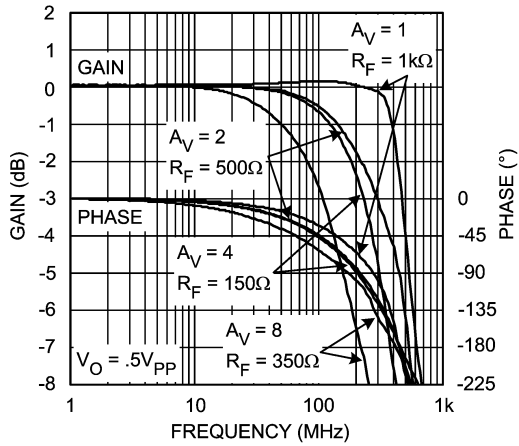

20088513

**Inverting Frequency Response**

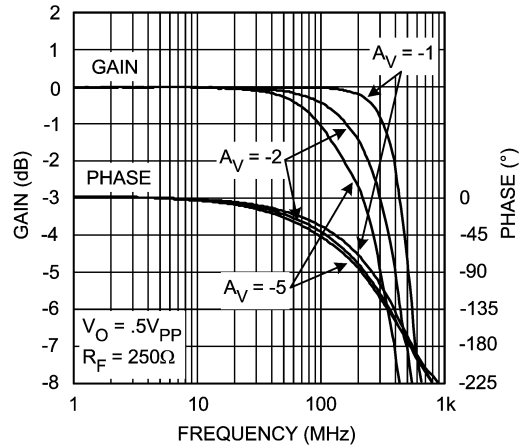

20088512

**Non-Inverting Frequency Response vs.  $V_{OUT}$**

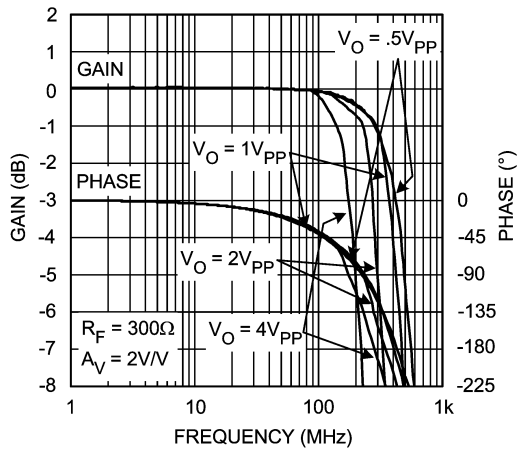

20088516

**Small Signal Channel Matching**

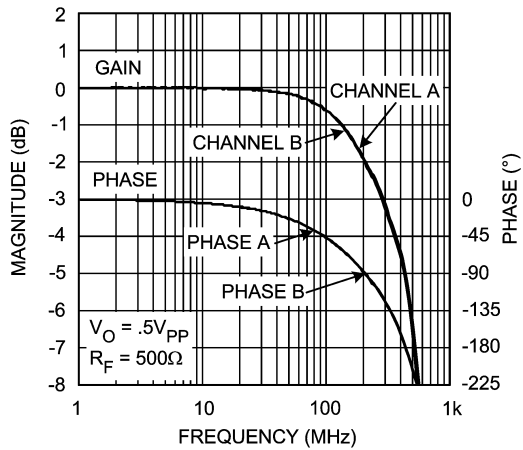

20088501

**Frequency Response vs. Load Resistance**

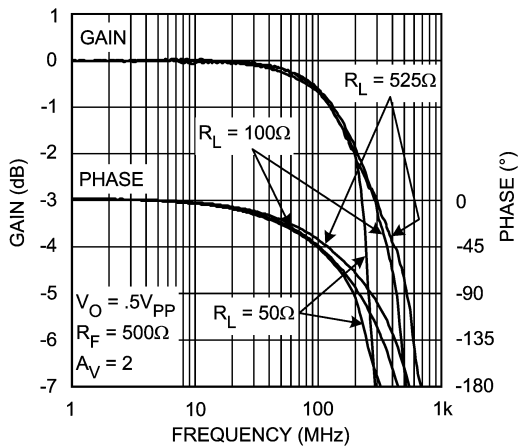

20088515

**Non-Inverting Frequency Response vs.  $R_F$**

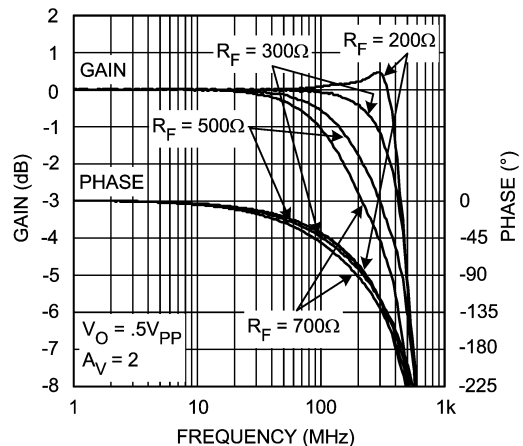

20088514

**Typical Performance Characteristics** ( $T_A = 25^\circ\text{C}$ ,  $V_{CC} = \pm 5\text{V}$ ,  $A_V = \pm 2\text{V/V}$ ,  $R_F = 500\Omega$ ,  $R_L = 100\Omega$ , unless otherwise specified). (Continued)

**Small Signal Pulse Response**

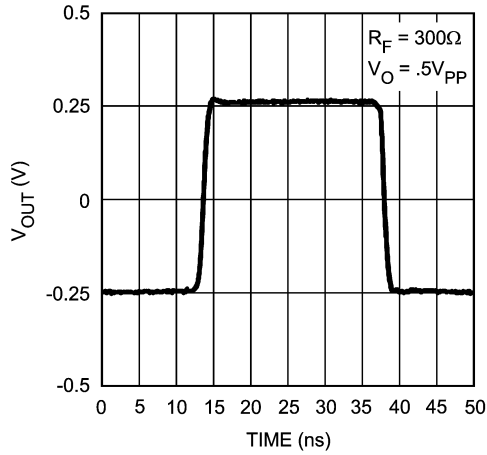

20088518

**Large Signal Pulse Response**

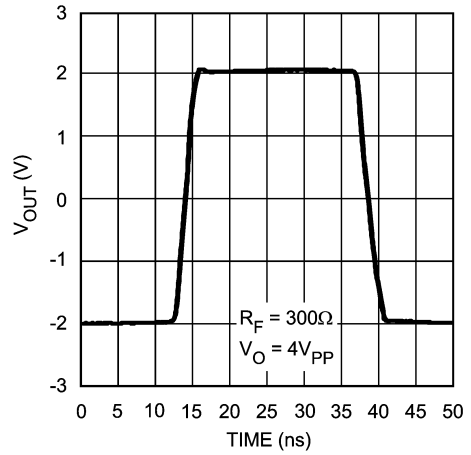

20088519

**Input-Referred Crosstalk**

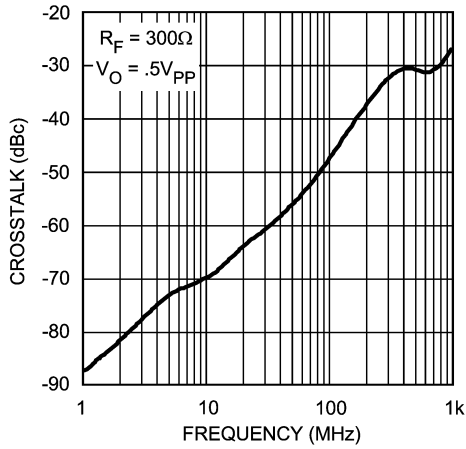

20088507

**Settling Time vs. Accuracy**

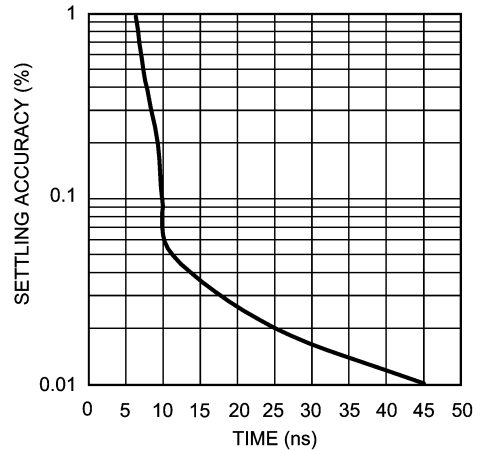

20088524

**-3dB Bandwidth vs.  $V_{OUT}$**

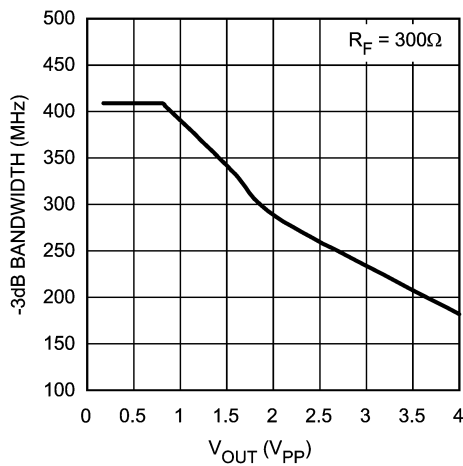

20088525

**DC Errors vs. Temperature**

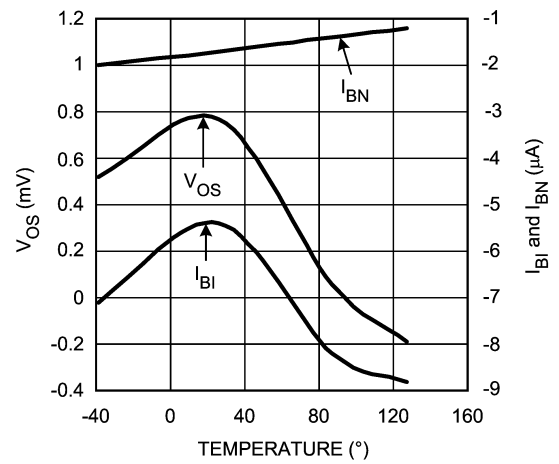

20088526

**Typical Performance Characteristics** ( $T_A = 25^\circ\text{C}$ ,  $V_{CC} = \pm 5\text{V}$ ,  $A_V = \pm 2\text{V/V}$ ,  $R_F = 500\Omega$ ,  $R_L = 100\Omega$ , unless otherwise specified). (Continued)

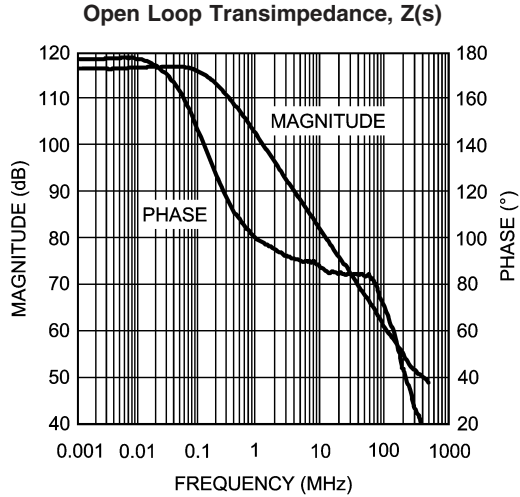

20088520

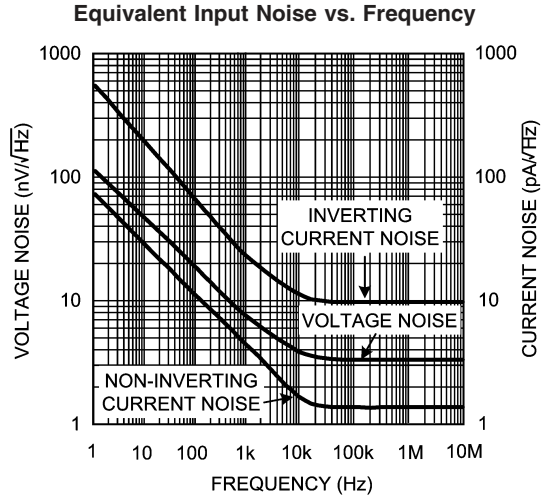

20088523

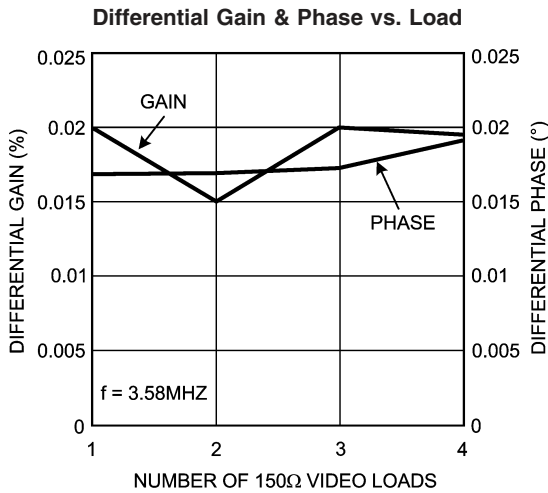

20088508

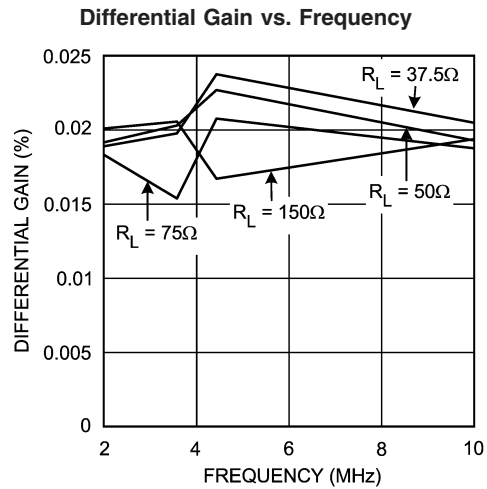

20088509

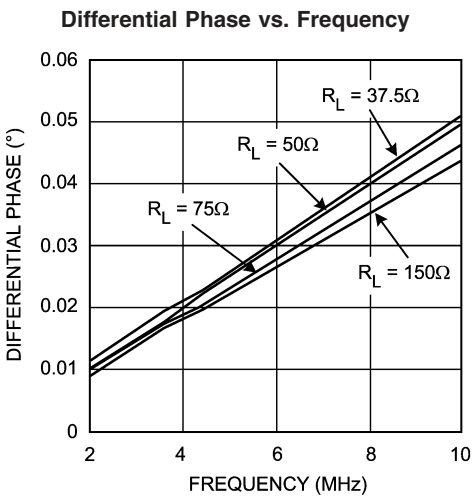

20088510

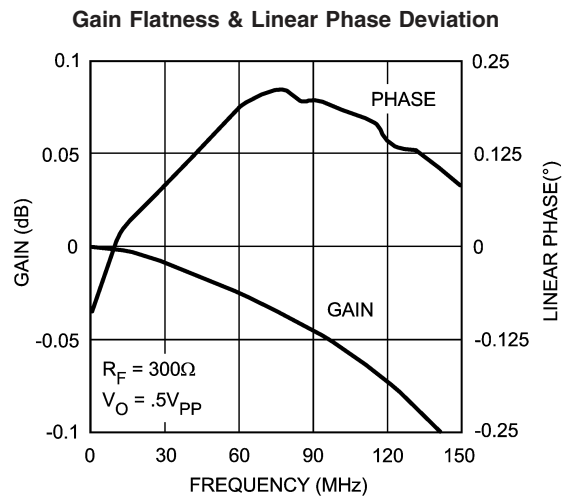

20088511

**Typical Performance Characteristics** ( $T_A = 25^\circ\text{C}$ ,  $V_{CC} = \pm 5\text{V}$ ,  $A_V = \pm 2\text{V/V}$ ,  $R_F = 500\Omega$ ,  $R_L = 100\Omega$ , unless otherwise specified). (Continued)

**2nd Harmonic Distortion vs. Output Voltage**

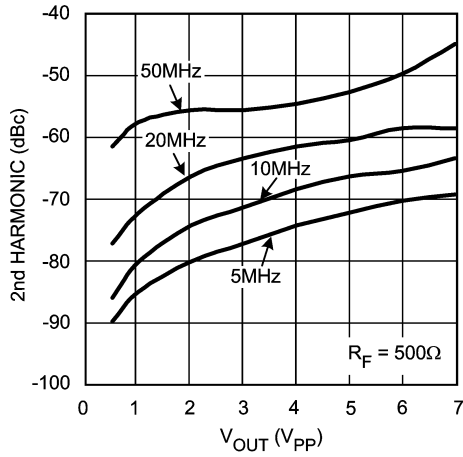

20088502

**3rd Harmonic Distortion vs. Output Voltage**

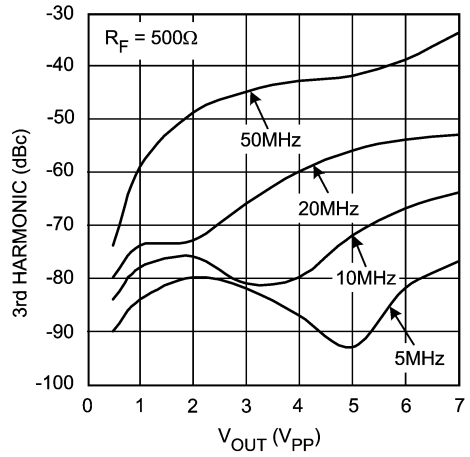

20088505

**Closed Loop Output Resistance**

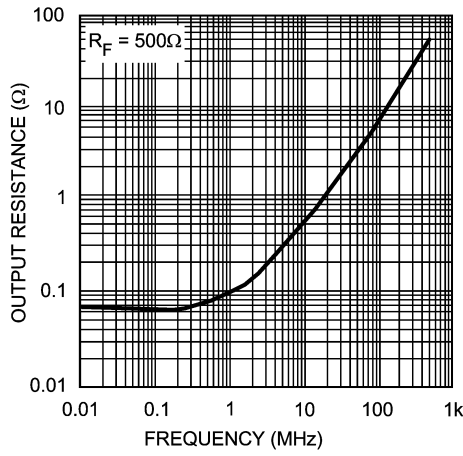

20088506

**PSRR & CMRR**

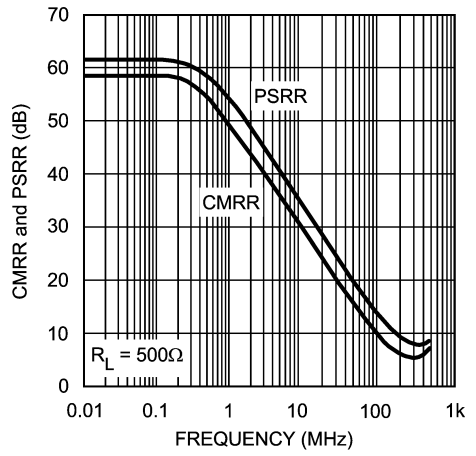

20088517

**Suggested  $R_S$  vs.  $C_L$**

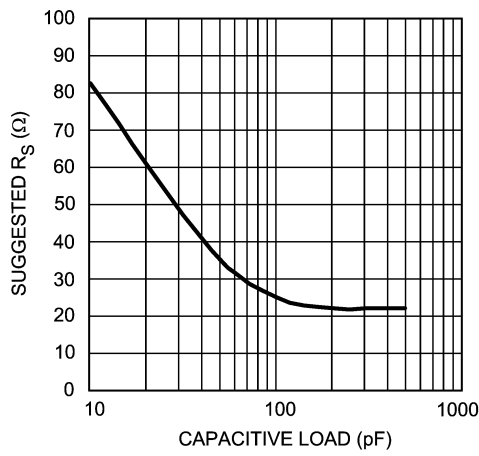

20088527

## Application Section

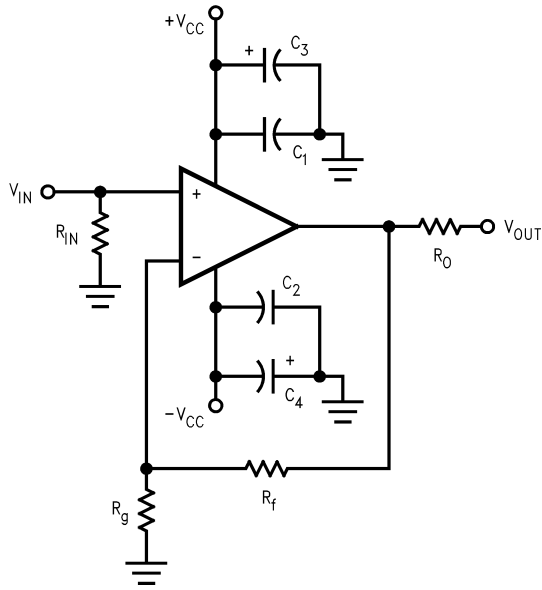

20088535

**FIGURE 1. Non-Inverting Configuration with Power Supply Bypassing**

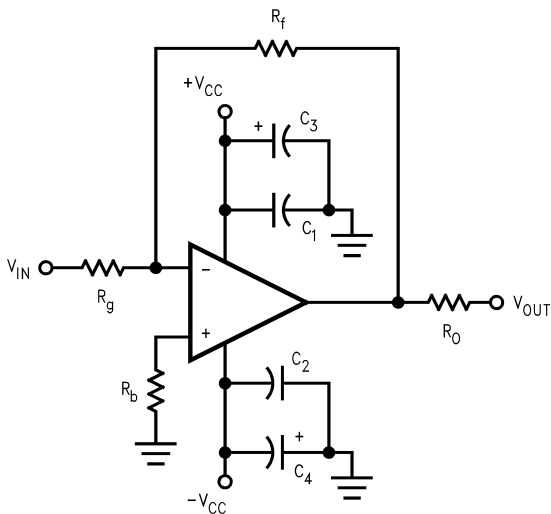

20088537

**FIGURE 2. Inverting Configuration with Power Supply Bypassing**

## Application Introduction

Offered in an 8-pin package for reduced space and cost, the wideband LMH6715EP dual current-feedback op amp provides closely matched DC and AC electrical performance characteristics making the part an ideal choice for wideband signal processing. Applications such as broadcast quality video systems, IQ amplifiers, filter blocks, high speed peak detectors, integrators and transimpedance amplifiers will all find superior performance in the LMH6715EP dual op amp.

## FEEDBACK RESISTOR SELECTION

One of the key benefits of a current feedback operational amplifier is the ability to maintain optimum frequency response independent of gain by using appropriate values for the feedback resistor ( $R_F$ ). The Electrical Characteristics and Typical Performance plots specify an  $R_F$  of  $500\Omega$ , a gain of  $+2V/V$  and  $\pm 5V$  power supplies (unless otherwise specified). Generally, lowering  $R_F$  from its recommended value will peak the frequency response and extend the bandwidth while increasing the value of  $R_F$  will cause the frequency response to roll off faster. Reducing the value of  $R_F$  too far below its recommended value will cause overshoot, ringing and, eventually, oscillation.

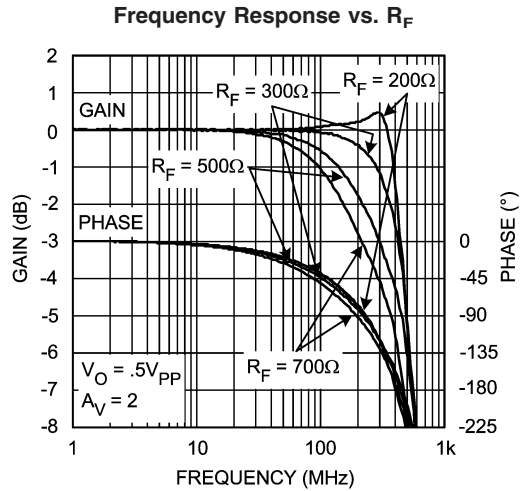

20088514

The plot labeled “Frequency Response vs.  $R_F$ ” shows the LMH6715EP’s frequency response as  $R_F$  is varied ( $R_L = 100\Omega$ ,  $A_V = +2$ ). This plot shows that an  $R_F$  of  $200\Omega$  results in peaking and marginal stability. An  $R_F$  of  $300\Omega$  gives near maximal bandwidth and gain flatness with good stability, but with very light loads ( $R_L > 300\Omega$ ) the device may show some peaking. An  $R_F$  of  $500\Omega$  gives excellent stability with good bandwidth and is the recommended value for most applications. Since all applications are slightly different it is worth some experimentation to find the optimal  $R_F$  for a given circuit. For more information see Application Note OA-13 which describes the relationship between  $R_F$  and closed-loop frequency response for current feedback operational amplifiers.

When configuring the LMH6715EP for gains other than  $+2V/V$ , it is usually necessary to adjust the value of the feedback resistor. The two plots labeled “ $R_F$  vs. Non-inverting Gain” and “ $R_F$  vs. Inverting Gain” provide recommended feedback resistor values for a number of gain selections.

## Application Introduction (Continued)

### $R_F$ vs. Non-Inverting Gain

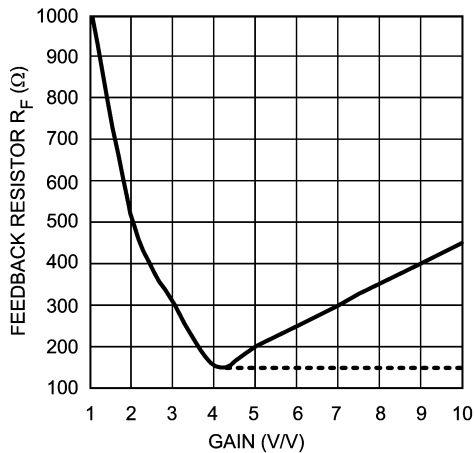

20088521

Both plots show the value of  $R_F$  approaching a minimum value (dashed line) at high gains. Reducing the feedback resistor below this value will result in instability and possibly oscillation. The recommended value of  $R_F$  is depicted by the solid line, which begins to increase at higher gains. The reason that a higher  $R_F$  is required at higher gains is the need to keep  $R_G$  from decreasing too far below the output impedance of the input buffer. For the LMH6715EP the output resistance of the input buffer is approximately 160Ω and 50Ω is a practical lower limit for  $R_G$ . Due to the limitations on  $R_G$  the LMH6715EP begins to operate in a gain bandwidth limited fashion for gains of  $\pm 5V/V$  or greater.

### $R_F$ vs. Inverting Gain

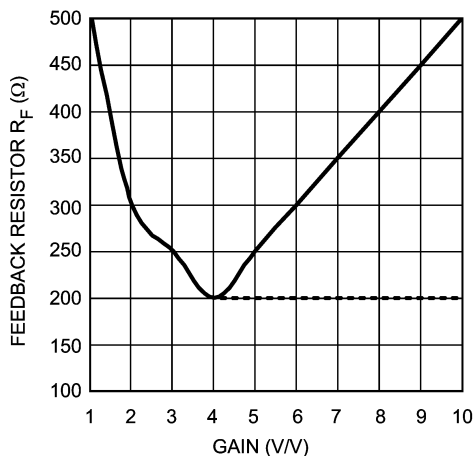

20088522

When using the LMH6715EP as a replacement for the CLC412, identical bandwidth can be obtained by using an appropriate value of  $R_F$ . The chart "Frequency Response vs.  $R_F$ " shows that an  $R_F$  of approximately 700Ω will provide bandwidth very close to that of the CLC412. At other gains a similar increase in  $R_F$  can be used to match the new and old parts.

### CIRCUIT LAYOUT

With all high frequency devices, board layouts with stray capacitances have a strong influence over AC performance. The LMH6715EP is no exception and its input and output

pins are particularly sensitive to the coupling of parasitic capacitances (to AC ground) arising from traces or pads placed too closely (<0.1") to power or ground planes. In some cases, due to the frequency response peaking caused by these parasitics, a small adjustment of the feedback resistor value will serve to compensate the frequency response. Also, it is very important to keep the parasitic capacitance across the feedback resistor to an absolute minimum.

The performance plots in the data sheet can be reproduced using the evaluation boards available from National. The CLC730036 board uses all SMT parts for the evaluation of the LMH6715EP. The board can serve as an example layout for the final production printed circuit board.

Care must also be taken with the LMH6715EP's layout in order to achieve the best circuit performance, particularly channel-to-channel isolation. The decoupling capacitors (both tantalum and ceramic) must be chosen with good high frequency characteristics to decouple the power supplies and the physical placement of the LMH6715EP's external components is critical. Grouping each amplifier's external components with their own ground connection and separating them from the external components of the opposing channel with the maximum possible distance is recommended. The input ( $R_{IN}$ ) and gain setting resistors ( $R_F$ ) are the most critical. It is also recommended that the ceramic decoupling capacitor (0.1μF chip or radial-leaded with low ESR) should be placed as closely to the power pins as possible.

### POWER DISSIPATION

Follow these steps to determine the Maximum power dissipation for the LMH6715EP:

1. Calculate the quiescent (no-load) power:  $P_{AMP} = I_{CC} (V_{CC} - V_{EE})$
2. Calculate the RMS power at the output stage:  $P_O = (V_{CC} - V_{LOAD})(I_{LOAD})$ , where  $V_{LOAD}$  and  $I_{LOAD}$  are the voltage and current across the external load.
3. Calculate the total RMS power:  $P_t = P_{AMP} + P_O$

The maximum power that the LMH6715EP, package can dissipate at a given temperature can be derived with the following equation:

$P_{max} = (150^\circ - T_{amb}) / \theta_{JA}$ , where  $T_{amb}$  = Ambient temperature ( $^\circ C$ ) and  $\theta_{JA}$  = Thermal resistance, from junction to ambient, for a given package ( $^\circ C/W$ ). For the SOIC package  $\theta_{JA}$  is 145  $^\circ C/W$ .

### MATCHING PERFORMANCE

With proper board layout, the AC performance match between the two LMH6715EP's amplifiers can be tightly controlled as shown in Typical Performance plot labeled "Small-Signal Channel Matching".

The measurements were performed with SMT components using a feedback resistor of 300Ω at a gain of +2V/V.

The LMH6715EP's amplifiers, built on the same die, provide the advantage of having tightly matched DC characteristics.

### SLEW RATE AND SETTLING TIME

One of the advantages of current-feedback topology is an inherently high slew rate which produces a wider full power bandwidth. The LMH6715EP has a typical slew rate of 1300V/μs. The required slew rate for a design can be calculated by the following equation:  $SR = 2\pi fV_{pk}$ .

## Application Introduction (Continued)

Careful attention to parasitic capacitances is critical to achieving the best settling time performance. The LMH6715EP has a typical short term settling time to 0.05% of 12ns for a 2V step. Also, the amplifier is virtually free of any long term thermal tail effects at low gains.

When measuring settling time, a solid ground plane should be used in order to reduce ground inductance which can cause common-ground-impedance coupling. Power supply and ground trace parasitic capacitances and the load capacitance will also affect settling time.

Placing a series resistor ( $R_s$ ) at the output pin is recommended for optimal settling time performance when driving a capacitive load. The Typical Performance plot labeled “ $R_s$  and Settling Time vs. Capacitive Load” provides a means for selecting a value of  $R_s$  for a given capacitive load.

### DC & NOISE PERFORMANCE

A current-feedback amplifier’s input stage does not have equal nor correlated bias currents, therefore they cannot be canceled and each contributes to the total DC offset voltage at the output by the following equation:

$$V_{\text{OFFSET}} = \pm \left[ I_{\text{BN}} \times R_s \left[ 1 + \frac{R_f}{R_g} \right] + V_{\text{IO}} \left[ 1 + \frac{R_f}{R_g} \right] + I_{\text{BI}} \times R_f \right]$$

The input resistance is the resistance looking from the non-inverting input back toward the source. For inverting DC-offset calculations, the source resistance seen by the input resistor  $R_g$  must be included in the output offset calculation as a part of the non-inverting gain equation. Application note OA-7 gives several circuits for DC offset correction. The noise currents for the inverting and non-inverting inputs are graphed in the Typical Performance plot labeled “Equivalent Input Noise”. A more complete discussion of amplifier input-referred noise and external resistor noise contribution can be found in OA-12.

### DIFFERENTIAL GAIN & PHASE

The LMH6715EP can drive multiple video loads with very low differential gain and phase errors. The Typical Performance plots labeled “Differential Gain vs. Frequency” and “Differential Phase vs. Frequency” show performance for loads from 1 to 4. The Electrical Characteristics table also specifies performance for one 150Ω load at 4.43MHz. For NTSC video, the performance specifications also apply. Application note OA-24 “Measuring and Improving Differential Gain & Differential Phase for Video”, describes in detail the techniques used to measure differential gain and phase.

### I/O VOLTAGE & OUTPUT CURRENT

The usable common-mode input voltage range (CMIR) of the LMH6715EP specified in the Electrical Characteristics table of the data sheet shows a range of ±2.2 volts. Exceeding this range will cause the input stage to saturate and clip the output signal.

The output voltage range is determined by the load resistor and the choice of power supplies. With ±5 volts the class A/B output driver will typically drive ±3.9V into a load resistance of 100Ω. Increasing the supply voltages will change the common-mode input and output voltage swings while at the same time increase the internal junction temperature.

## Applications Circuits

### SINGLE-TO-DIFFERENTIAL LINE DRIVER

The LMH6715EP’s well matched AC channel-response allows a single-ended input to be transformed to highly matched push-pull driver. From a 1V single-ended input the circuit of *Figure 3* produces 1V differential signal between the two outputs. For larger signals the input voltage divider ( $R_1 = 2R_2$ ) is necessary to limit the input voltage on channel 2.

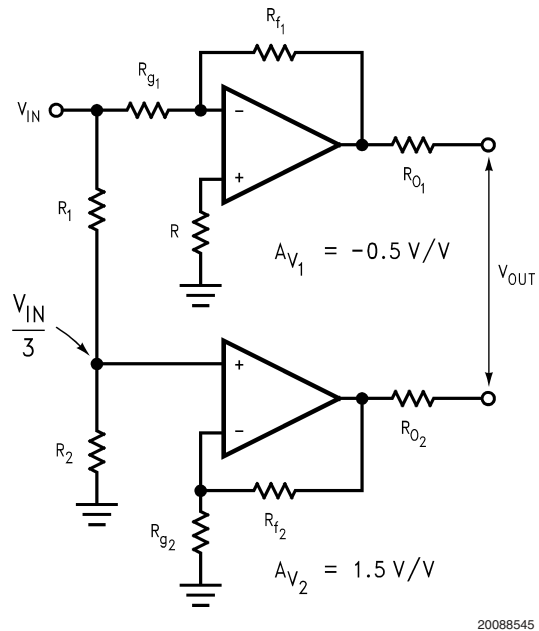

20088545

FIGURE 3. Single-to-Differential Line Driver

### DIFFERENTIAL LINE RECEIVER

*Figure 4* and *Figure 5* show two different implementations of an instrumentation amplifier which convert differential signals to single-ended. *Figure 5* allows CMRR adjustment through  $R_2$ .

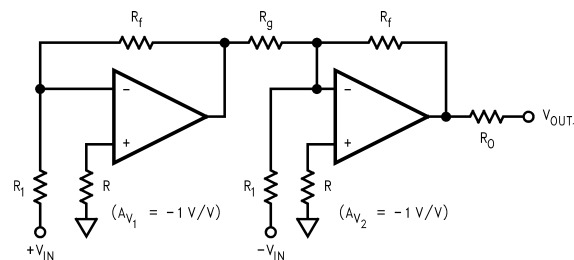

20088546

FIGURE 4. Differential Line Receiver

## Applications Circuits (Continued)

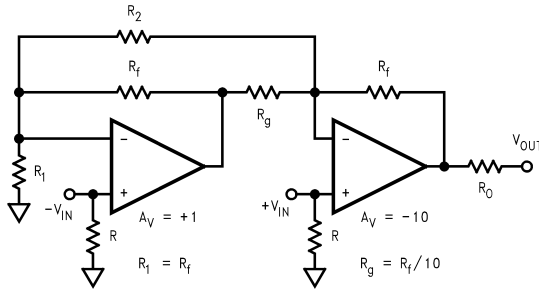

20088547

**FIGURE 5. Differential Line Receiver with CMRR Adjustment**

### NON-INVERTING CURRENT-FEEDBACK INTEGRATOR

The circuit of *Figure 6* achieves its high speed integration by placing one of the LMH6715EP's amplifiers in the feedback loop of the second amplifier configured as shown.

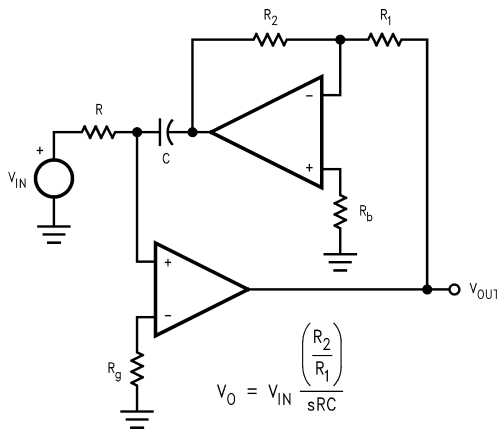

20088549

**FIGURE 6. Current Feedback Integrator**

### LOW NOISE WIDE-BANDWIDTH TRANSIMPEDANCE AMPLIFIER

*Figure 7* implements a low noise transimpedance amplifier using both channels of the LMH6715EP. This circuit takes advantage of the lower input bias current noise of the non-inverting input and achieves negative feedback through the second LMH6715EP channel. The output voltage is set by the value of  $R_F$  while frequency compensation is achieved through the adjustment of  $R_T$ .

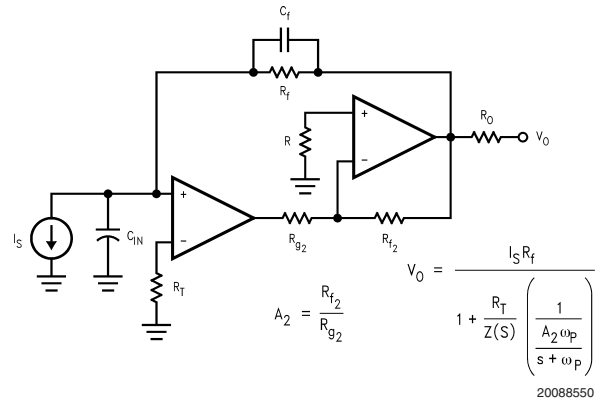

20088550

**FIGURE 7. Low-Noise, Wide Bandwidth, Transimpedance Amp.**

## Physical Dimensions inches (millimeters)

unless otherwise noted

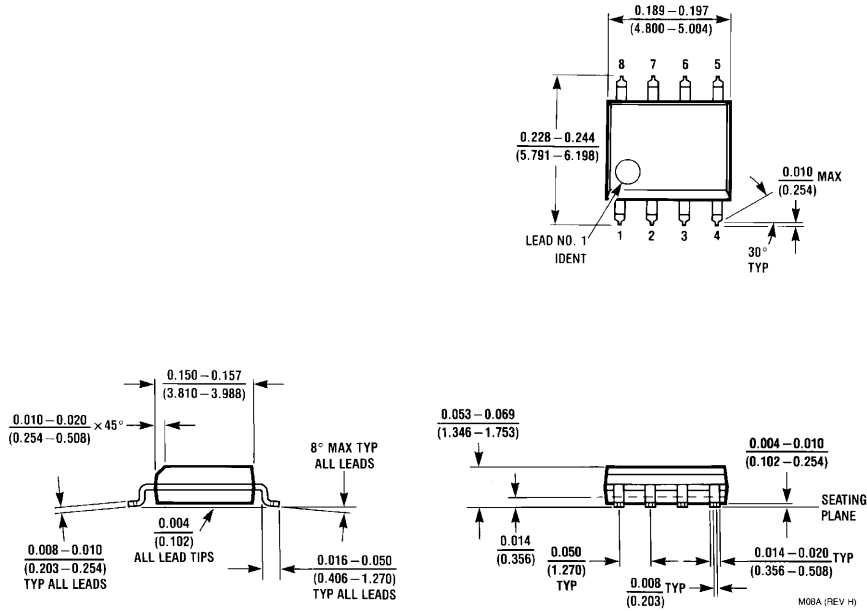

**8-Pin SOIC  
NS Package Number M08A**

### LIFE SUPPORT POLICY

NATIONAL'S PRODUCTS ARE NOT AUTHORIZED FOR USE AS CRITICAL COMPONENTS IN LIFE SUPPORT DEVICES OR SYSTEMS WITHOUT THE EXPRESS WRITTEN APPROVAL OF THE PRESIDENT AND GENERAL COUNSEL OF NATIONAL SEMICONDUCTOR CORPORATION. As used herein:

1. Life support devices or systems are devices or systems which, (a) are intended for surgical implant into the body, or (b) support or sustain life, and whose failure to perform when properly used in accordance with instructions for use provided in the labeling, can be reasonably expected to result in a significant injury to the user.
2. A critical component is any component of a life support device or system whose failure to perform can be reasonably expected to cause the failure of the life support device or system, or to affect its safety or effectiveness.

### BANNED SUBSTANCE COMPLIANCE

National Semiconductor certifies that the products and packing materials meet the provisions of the Customer Products Stewardship Specification (CSP-9-111C2) and the Banned Substances and Materials of Interest Specification (CSP-9-111S2) and contain no "Banned Substances" as defined in CSP-9-111S2.



**National Semiconductor**  
Americas Customer  
Support Center  
Email: [new.feedback@nsc.com](mailto:new.feedback@nsc.com)  
Tel: 1-800-272-9959

**National Semiconductor**  
Europe Customer Support Center  
Fax: +49 (0) 180-530 85 86  
Email: [europe.support@nsc.com](mailto:europe.support@nsc.com)  
Deutsch Tel: +49 (0) 69 9508 6208  
English Tel: +44 (0) 870 24 0 2171  
Français Tel: +33 (0) 1 41 91 8790

**National Semiconductor**  
Asia Pacific Customer  
Support Center  
Email: [ap.support@nsc.com](mailto:ap.support@nsc.com)

**National Semiconductor**  
Japan Customer Support Center  
Fax: 81-3-5639-7507  
Email: [jpn.feedback@nsc.com](mailto:jpn.feedback@nsc.com)  
Tel: 81-3-5639-7560

[www.national.com](http://www.national.com)