

LMP2012QML

Dual High Precision, Rail-to-Rail Output Operational Amplifier

General Description

The LMP2012 is the first member of National's QML certified new LMP™ precision amplifier family. The LMP2012 offers unprecedented accuracy and stability. This device utilizes patented techniques to measure and continually correct the input offset error voltage. The result is an amplifier which is ultra stable over time and temperature. It has excellent CMRR and PSRR ratings, and does not exhibit the familiar 1/f voltage and current noise increase that plagues traditional amplifiers. The combination of the LMP2012 characteristics makes it a good choice for transducer amplifiers, high gain configurations, ADC buffer amplifiers, DAC I-V conversion, and any other 2.7V-5V application requiring precision and long term stability.

Other useful benefits of the LMP2012 are rail-rail output, low supply current of 930 μ A, and wide gain-bandwidth product of 3 MHz. These extremely versatile features found in the LMP2012 provide high performance and ease of use.

The QMLV version of the LMP2012 has been rated to tolerate a total dose level of 50krad/(Si) radiation by test method 1019 of MIL-STD-883.

Features

- Available with radiation guarantee (For $V_S = 5V$, Typical unless otherwise noted)
- Low guaranteed V_{IO} over temperature
- Low noise with no 1/f
- High CMRR
- High PSRR
- High A_{VOL}
- Wide gain-bandwidth product
- High slew rate
- Rail-to-rail output
- No external capacitors required

60 μ V
35nV/ \sqrt{Hz}
90 dB
90 dB
85 dB
3MHz
4V/ μ s
30mV

Applications

- Attitude and Orbital Controls
- Static Earth Sensing
- Sun Sensors
- Inertial Sensors
- Pressure Sensors
- Gyroscopes
- Earth Observation Systems

Ordering Information

NS PART NUMBER	SMD PART NUMBER	NS PACKAGE NUMBER	PACKAGE DESCRIPTION
LMP2012WG-QMLV	5962-0620601VZA	WG10A	10LD CERAMIC SOIC
LMP2012WGLQMLV	5962L0620601VZA 50K rd(Si)	WG10A	10LD CERAMIC SOIC

Connection Diagram

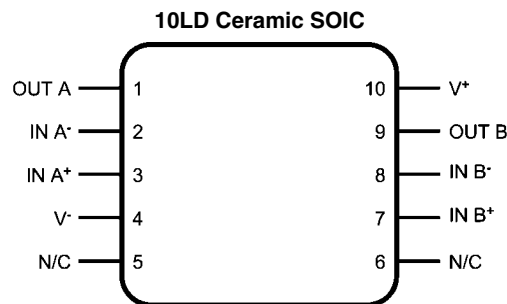

Top View
See NS Package Number WG10A

20182202

Absolute Maximum Ratings (Note 1)

Supply Voltage	5.8V
Differential Input Voltage	±Supply Voltage
Power Dissipation (Note 2)	714mW
Maximum Junction Temperature (T_{Jmax})	150°C
Common-Mode Input Voltage	$-0.3 \leq V_{CM} \leq V_{CC} + 0.3V$
Current at Input Pin	30 mA
Current at Output Pin	30 mA
Current at Power Supply Pin	50 mA
Operating Temperature Range	-55°C to +125°C
Storage Temperature Range	-55°C to +150°C
Ceramic SOIC Lead Temperature (soldering 10 sec.)	+260°C
Thermal Resistance	
θ_{JA}	
Ceramic SOIC (Still Air)	175°C/W
Ceramic SOIC (500LF/Min Air Flow)	115°C/W
θ_{JC}	
Ceramic SOIC	12.3°C/W
Package Weight	
Ceramic SOIC	220mg
ESD Tolerance (Note 3)	4000V

Quality Conformance Inspection

Mil-Std-883, Method 5005 - Group A

Subgroup	Description	Temp (°C)
1	Static tests at	+25
2	Static tests at	+125
3	Static tests at	-55
4	Dynamic tests at	+25
5	Dynamic tests at	+125
6	Dynamic tests at	-55
7	Functional tests at	+25
8A	Functional tests at	+125
8B	Functional tests at	-55
9	Switching tests at	+25
10	Switching tests at	+125
11	Switching tests at	-55
12	Setting time at	+25
13	Setting time at	+125
14	Setting time at	-55

LMP2012 Electrical Characteristics

2.7V DC Parameters

The following conditions apply, unless otherwise specified.

$V^+ = 2.7V$, $V^- = 0V$, $V_{CM} = 1.35V$, $V_O = 1.35V$ and $R_L > 1 M\Omega$.

Symbol	Parameter	Conditions	Notes	Typ (Note 4)	Min	Max	Units	Sub-groups
V_{IO}	Input Offset Voltage			0.8		36	μV	1
						60		2, 3
	Offset Calibration Time			0.5		10	ms	1
						12		2, 3
I_{IB}	Input Bias Current			-3			μA	
I_{IO}	Input Offset Current			6			μA	
CMRR	Common Mode Rejection Ratio	$-0.3 \leq V_{CM} \leq 0.9V$		130	95		dB	1
		$0 \leq V_{CM} \leq 0.9V$			90			2, 3
PSRR	Power Supply Rejection Ratio			120	95		dB	1
					90			2, 3
A_{VOL}	Open Loop Voltage Gain	$R_L = 10 k\Omega$		130	95		dB	1
					90			2, 3
		$R_L = 2 k\Omega$		124	90			1
					85			2, 3
V_O	Output Swing	$R_L = 10 k\Omega$ to 1.35V $V_{IN}(\text{diff}) = \pm 0.5V$		2.68	2.64		V	1
					2.63			2, 3
				0.033		0.060		1
						0.075		2, 3
		$R_L = 2 k\Omega$ to 1.35V $V_{IN}(\text{diff}) = \pm 0.5V$		2.65	2.615		V	1
					2.6			2, 3
				0.061		0.085		1
						0.105		2, 3
I_O	Output Current	Sourcing, $V_O = 0V$ $V_{IN}(\text{diff}) = \pm 0.5V$		12	5		mA	1
					3			2, 3
		Sinking, $V_O = 5V$ $V_{IN}(\text{diff}) = \pm 0.5V$		18	5			1
					3			2, 3
I_S	Supply Current per Channel			0.919		1.20	mA	1
						1.50		2, 3

2.7V AC Parameters

The following conditions apply, unless otherwise specified.

$V^+ = 2.7V$, $V^- = 0V$, $V_{CM} = 1.35V$, $V_O = 1.35V$, and $R_L > 1 M\Omega$.

Symbol	Parameter	Conditions	Notes	Typ (Note 4)	Min	Max	Units	Sub-groups
GBW	Gain-Bandwidth Product			3	1	5	MHz	4
SR	Slew Rate			4			V/ μs	

2.7V DC Parameters – 50K Post Radiation Limits @ +25°C

The following conditions apply, unless otherwise specified.

$V^+ = 2.7V$, $V^- = 0V$, $V_{CM} = 1.35V$, $V_O = 1.35V$, and $R_L > 1 M\Omega$.

Symbol	Parameter	Conditions	Notes	Typ	Min	Max	Units	Sub-groups
I_S	Supply Current per Channel		(Note 5)			1.75	mA	1

5V DC Parameters

The following conditions apply, unless otherwise specified.

$V^+ = 5V$, $V^- = 0V$, $V_{CM} = 2.5V$, $V_O = 2.5V$ and $R_L > 1M\Omega$.

Symbol	Parameter	Conditions	Notes	Typ (Note 4)	Min	Max	Units	Sub-groups
V_{IO}	Input Offset Voltage			0.12		36	μV	1
						60		2, 3
	Offset Calibration Time			0.5		10	ms	1
					12	2, 3		
I_{IB}	Input Bias Current			-3			pA	
I_{IO}	Input Offset Current			6			pA	
CMRR	Common Mode Rejection Ratio	$-0.3 \leq V_{CM} \leq 3.2$		130	100		dB	1
		$0 \leq V_{CM} \leq 3.2$			90			2, 3
PSRR	Power Supply Rejection Ratio			120	95		dB	1
					90			2, 3
A_{VOL}	Open Loop Voltage Gain	$R_L = 10\text{ k}\Omega$		130	105		dB	1
					100			2, 3
		$R_L = 2\text{ k}\Omega$		132	95			1
					90			2, 3
V_O	Output Swing	$R_L = 10\text{ k}\Omega$ to 2.5V $V_{IN}(\text{diff}) = \pm 0.5V$		4.978	4.92		V	1
					4.91			2, 3
				0.040		0.080		1
						0.095		2, 3
		$R_L = 2\text{ k}\Omega$ to 2.5V $V_{IN}(\text{diff}) = \pm 0.5V$		4.919	4.875		V	1
					4.855			2, 3
				0.091		0.125		1
						0.150		2, 3
I_O	Output Current	Sourcing, $V_O = 0V$ $V_{IN}(\text{diff}) = \pm 0.5V$		15	8		mA	1
					6			2, 3
		Sourcing, $V_O = 5V$ $V_{IN}(\text{diff}) = \pm 0.5V$		17	8			1
					6			2, 3
I_S	Supply Current per Channel			0.930		1.20	mA	1
						1.50		2, 3

5V AC Parameters

The following conditions apply, unless otherwise specified.

$V^+ = 5V$, $V^- = 0V$, $V_{CM} = 2.5V$, $V_O = 2.5V$, and $R_L > 1M\Omega$.

Symbol	Parameter	Conditions	Notes	Typ (Note 4)	Min	Max	Units	Sub-groups
GBW	Gain-Bandwidth Product			3	1	5	MHz	4
SR	Slew Rate			4			V/ μs	

5V DC Parameters – 50K Post Radiation Limits @ +25°C

The following conditions apply, unless otherwise specified.

$V^+ = 5V$, $V^- = 0V$, $V_{CM} = 2.5V$, $V_O = 2.5V$, and $R_L > 1\text{ M}\Omega$.

Symbol	Parameter	Conditions	Notes	Typ	Min	Max	Units	Sub-groups
I_S	Supply Current per Channel		(Note 5)			1.75	mA	1

Note 1: Absolute Maximum Ratings indicate limits beyond which damage to the device may occur. Operating Ratings indicate conditions for which the device is functional, but do not guarantee specific performance limits. For guaranteed specifications and test conditions, see the Electrical Characteristics. The guaranteed specifications apply only for the test conditions listed. Some performance characteristics may degrade when the device is not operated under the listed test conditions.

Note 2: The maximum power dissipation must be derated at elevated temperatures and is dictated by T_{Jmax} (maximum junction temperature), θ_{JA} (package junction to ambient thermal resistance), and T_A (ambient temperature). The maximum allowable power dissipation at any temperature is $P_{Dmax} = (T_{Jmax} - T_A) / \theta_{JA}$ or the number given in the Absolute Maximum Ratings, whichever is lower.

Note 3: Human body model, 1.5 k Ω in series with 100 pF.

Note 4: Typical values represent the most likely parametric norm.

Note 5: Pre and post irradiation limits are identical to those listed under DC electrical characteristics except as listed in the Post Radiation Limits Table. These parts may be dose rate sensitive in a space environment and demonstrate enhanced low dose rate effect. Radiation end point limits for the noted parameters are guaranteed only for the conditions as specified in Mil-Std-883, Method 1019

Application Information

THE BENEFITS OF LMP2012 NO 1/f NOISE

Using patented methods, the LMP2012 eliminates the 1/f noise present in other amplifiers. That noise, which increases as frequency decreases, is a major source of measurement error in all DC-coupled measurements. Low-frequency noise appears as a constantly-changing signal in series with any measurement being made. As a result, even when the measurement is made rapidly, this constantly-changing noise signal will corrupt the result. The value of this noise signal can be surprisingly large. For example: If a conventional amplifier has a flat-band noise level of $10\text{nV}/\sqrt{\text{Hz}}$ and a noise corner of 10 Hz, the RMS noise at 0.001 Hz is $1\mu\text{V}/\sqrt{\text{Hz}}$. This is equivalent to a 0.50 μV peak-to-peak error, in the frequency range 0.001 Hz to 1.0 Hz. In a circuit with a gain of 1000, this produces a 0.50 mV peak-to-peak output error. This number of 0.001 Hz might appear unreasonably low, but when a data acquisition system is operating for 17 minutes, it has been on long enough to include this error. In this same time, the LMP2012 will only have a 0.21 mV output error. This is smaller by 2.4 x. Keep in mind that this 1/f error gets even larger at lower frequencies. At the extreme, many people try to reduce this error by integrating or taking several samples of the same signal. This is also doomed to failure because the 1/f nature of this noise means that taking longer samples just moves the measurement into lower frequencies where the noise level is even higher.

The LMP2012 eliminates this source of error. The noise level is constant with frequency so that reducing the bandwidth reduces the errors caused by noise.

OVERLOAD RECOVERY

The LMP2012 recovers from input overload much faster than most chopper-stabilized op amps. Recovery from driving the amplifier to 2X the full scale output, only requires about 40 ms. Many chopper-stabilized amplifiers will take from 250 ms to several seconds to recover from this same overload. This is because large capacitors are used to store the unadjusted offset voltage.

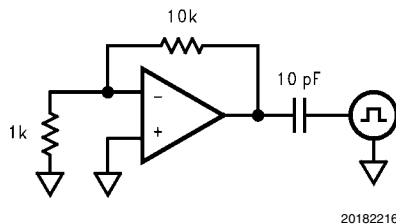

FIGURE 1.

The wide bandwidth of the LMP2012 enhances performance when it is used as an amplifier to drive loads that inject transients back into the output. ADCs (Analog-to-Digital Converters) and multiplexers are examples of this type of load. To simulate this type of load, a pulse generator producing a 1V peak square wave was connected to the output through a 10 pF capacitor. (Figure 1) The typical time for the output to recover to 1% of the applied pulse is 80 ns. To recover to 0.1% requires 860ns. This rapid recovery is due to the wide bandwidth of the output stage and large total GBW.

NO EXTERNAL CAPACITORS REQUIRED

The LMP2012 does not need external capacitors. This eliminates the problems caused by capacitor leakage and dielec-

tric absorption, which can cause delays of several seconds from turn-on until the amplifier's error has settled.

MORE BENEFITS

The LMP2012 offers the benefits mentioned above and more. It has a rail-to-rail output and consumes only 950 μA of supply current while providing excellent DC and AC electrical performance. In DC performance, the LMP2012 achieves 130 dB of CMRR, 120 dB of PSRR and 130 dB of open loop gain. In AC performance, the LMP2012 provides 3 MHz of gain-bandwidth product and 4 V/ μs of slew rate.

HOW THE LMP2012 WORKS

The LMP2012 uses new, patented techniques to achieve the high DC accuracy traditionally associated with chopper-stabilized amplifiers without the major drawbacks produced by chopping. The LMP2012 continuously monitors the input offset and corrects this error. The conventional chopping process produces many mixing products, both sums and differences, between the chopping frequency and the incoming signal frequency. This mixing causes large amounts of distortion, particularly when the signal frequency approaches the chopping frequency. Even without an incoming signal, the chopper harmonics mix with each other to produce even more trash. If this sounds unlikely or difficult to understand, look at the plot (Figure 2), of the output of a typical (MAX432) chopper-stabilized op amp. This is the output when there is no incoming signal, just the amplifier in a gain of -10 with the input grounded. The chopper is operating at about 150 Hz; the rest is mixing products. Add an input signal and the noise gets much worse. Compare this plot with Figure 3 of the LMP2012. This data was taken under the exact same conditions. The auto-zero action is visible at about 30 kHz but note the absence of mixing products at other frequencies. As a result, the LMP2012 has very low distortion of 0.02% and very low mixing products.

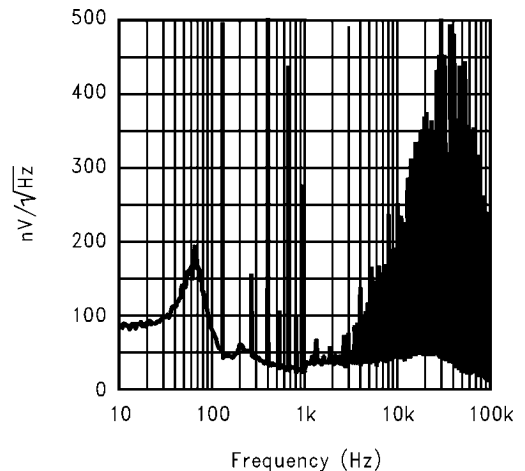

20182217

FIGURE 2.

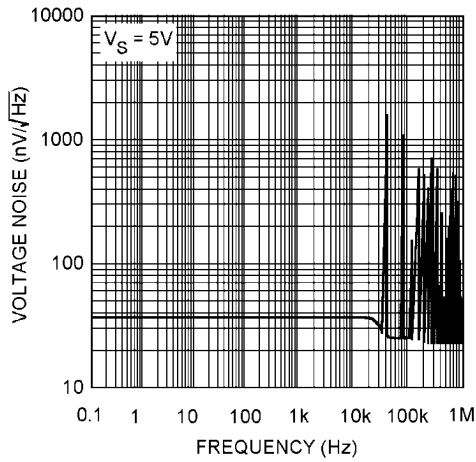

20182204

FIGURE 3.

INPUT CURRENTS

The LMP2012's input currents are different than standard bipolar or CMOS input currents in that it appears as a current flowing in one input and out the other. Under most operating conditions, these currents are in the picoamp level and will have little or no effect in most circuits. These currents tend to increase slightly when the common-mode voltage is near the minus supply. At high temperatures, the input currents become larger, 0.5 nA typical, and are both positive except when the V_{CM} is near V^- . If operation is expected at low common-mode voltages and high temperature, do not add resistance in series with the inputs to balance the impedances. Doing this can cause an increase in offset voltage. A small resistance such as 1 k Ω can provide some protection against very large transients or overloads, and will not increase the offset significantly.

PRECISION STRAIN-GAUGE AMPLIFIER

This Strain-Gauge amplifier (*Figure 4*) provides high gain (1006 or ~ 60 dB) with very low offset and drift. Using the resistors' tolerances as shown, the worst case CMRR will be greater than 108 dB. The CMRR is directly related to the resistor mismatch. The rejection of common-mode error, at the output, is independent of the differential gain, which is set by R3. The CMRR is further improved, if the resistor ratio matching is improved, by specifying tighter-tolerance resistors, or by trimming.

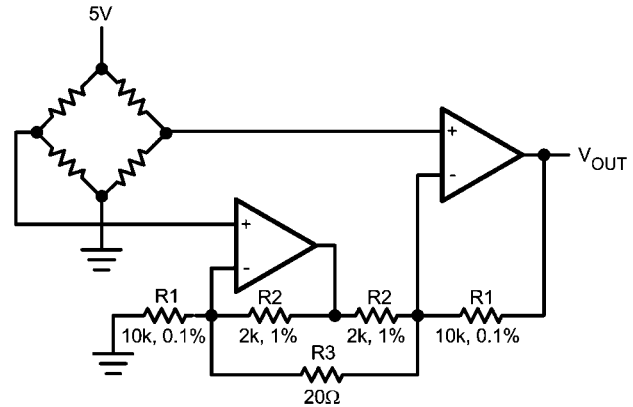

20182218

FIGURE 4.

Extending Supply Voltages and Output Swing by Using a Composite Amplifier Configuration:

In cases where substantially higher output swing is required with higher supply voltages, arrangements like the ones shown in *Figure 5* and *Figure 6* could be used. These configurations utilize the excellent DC performance of the LMP2012 while at the same time allow the superior voltage and frequency capabilities of the LM6171 to set the dynamic performance of the overall amplifier. For example, it is possible to achieve $\pm 12V$ output swing with 300 MHz of overall GBW ($A_v = 100$) while keeping the worst case output shift due to V_{OS} less than 4 mV. The LMP2012 output voltage is kept at about mid-point of its overall supply voltage, and its input common mode voltage range allows the V^- terminal to be grounded in one case (*Figure 5*, inverting operation) and tied to a small non-critical negative bias in another (*Figure 6*, non-inverting operation). Higher closed-loop gains are also possible with a corresponding reduction in realizable bandwidth. Table 1 shows some other closed loop gain possibilities along with the measured performance in each case.

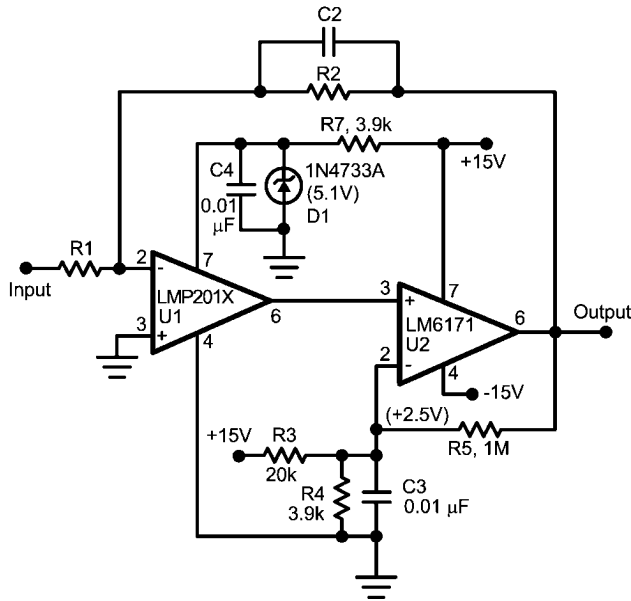

20182219

FIGURE 5.

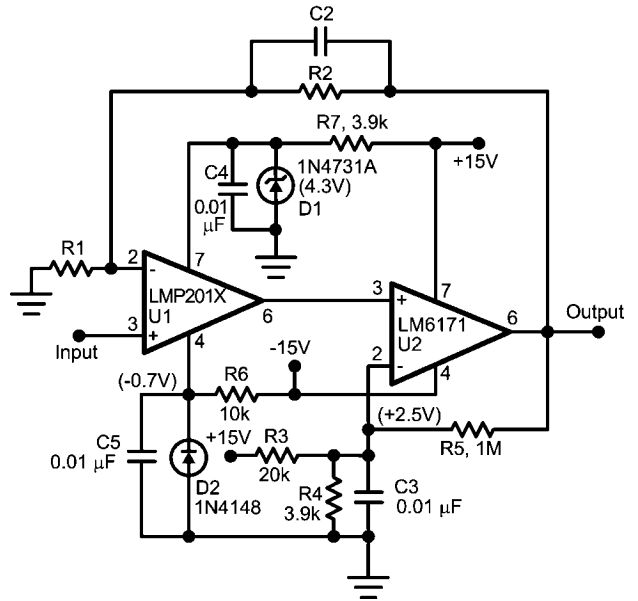

20182220

FIGURE 6.

TABLE 1. Composite Amplifier Measured Performance

AV	R1 Ω	R2 Ω	C2 pF	BW MHz	SR (V/μs)	en p-p (mV _{PP})
50	200	10k	8	3.3	178	37
100	100	10k	10	2.5	174	70
100	1k	100k	0.67	3.1	170	70
500	200	100k	1.75	1.4	96	250
1000	100	100k	2.2	0.98	64	400

In terms of the measured output peak-to-peak noise, the following relationship holds between output noise voltage, e_n p-p, for different closed-loop gain, A_V , settings, where -3 dB Bandwidth is BW:

It should be kept in mind that in order to minimize the output noise voltage for a given closed-loop gain setting, one could minimize the overall bandwidth. As can be seen from Equation 1 above, the output noise has a square-root relationship to the Bandwidth.

In the case of the inverting configuration, it is also possible to increase the input impedance of the overall amplifier, by raising the value of R1, without having to increase the feedback resistor, R2, to impractical values, by utilizing a "Tee" network as feedback. See the LMC6442 data sheet (Application Notes section) for more details on this.

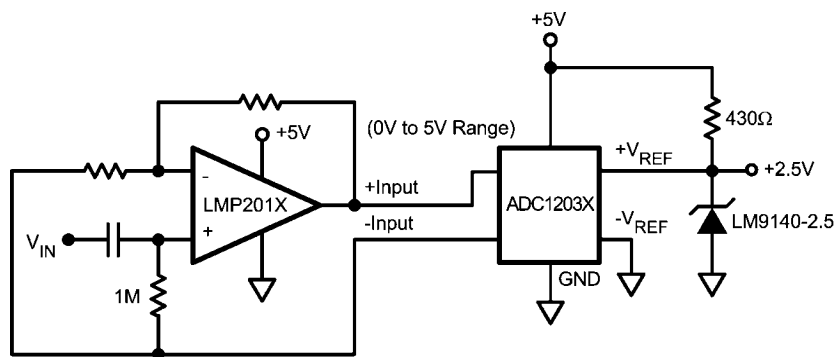

20182221

FIGURE 7.

LMP2012 AS ADC INPUT AMPLIFIER

The LMP2012 is a great choice for an amplifier stage immediately before the input of an ADC (Analog-to-Digital Converter), whether AC or DC coupled. See Figure 7 and Figure 8. This is because of the following important characteristics:

- A) Very low offset voltage and offset voltage drift over time and temperature allow a high closed-loop gain setting without introducing any short-term or long-term errors. For example, when set to a closed-loop gain of 100 as the

analog input amplifier for a 12-bit A/D converter, the overall conversion error over full operation temperature and 30 years life of the part (operating at 50°C) would be less than 5 LSBs.

- B)** Fast large-signal settling time to 0.01% of final value (1.4 μ s) allows 12 bit accuracy at 100 KHz or more sampling rate.
- C)** No flicker (1/f) noise means unsurpassed data accuracy over any measurement period of time, no matter how long. Consider the following op amp performance, based on a typical low-noise, high-performance commercially-available device, for comparison:

Op amp flatband noise = $8\text{nV}/\sqrt{\text{Hz}}$

1/f corner frequency = 100 Hz

$A_V = 2000$

Measurement time = 100 sec

Bandwidth = 2 Hz

This example will result in about 2.2 mV_{PP} (1.9 LSB) of output noise contribution due to the op amp alone, compared to about 594 μ V_{PP} (less than 0.5 LSB) when that op amp is replaced with the LMP2012 which has no 1/f contribution. If the measurement time is increased from 100 seconds to 1 hour, the improvement realized by using the LMP2012 would be a factor of about 4.8 times (2.86 mV_{PP} compared to 596 μ V when LMP2012 is used) mainly because the LMP2012 accuracy is not compromised by increasing the observation time.

- D)** Rail-to-Rail output swing maximizes the ADC dynamic range in 5-Volt single-supply converter applications. Below are some typical block diagrams showing the LMP2012 used as an ADC amplifier (*Figure 7 and Figure 8*).

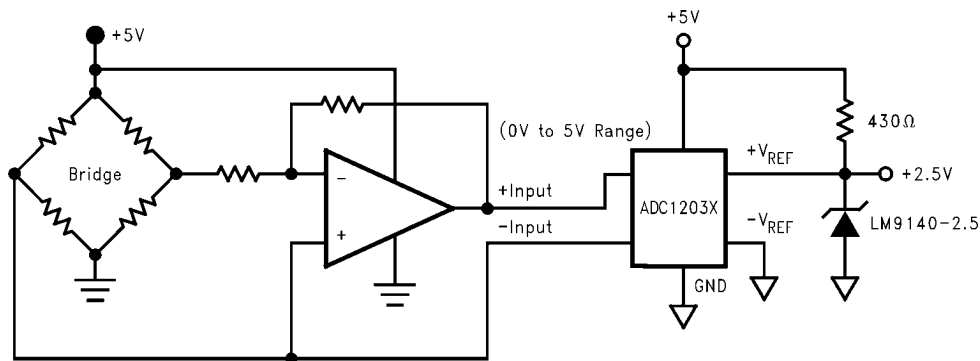

20182222

FIGURE 8.

Revision History

Date Released	Revision	Section	Originator	Changes
03/19/07	A	Initial Release	B. Petcher/B. Brown	Initial Release

Physical Dimensions inches (millimeters) unless otherwise noted

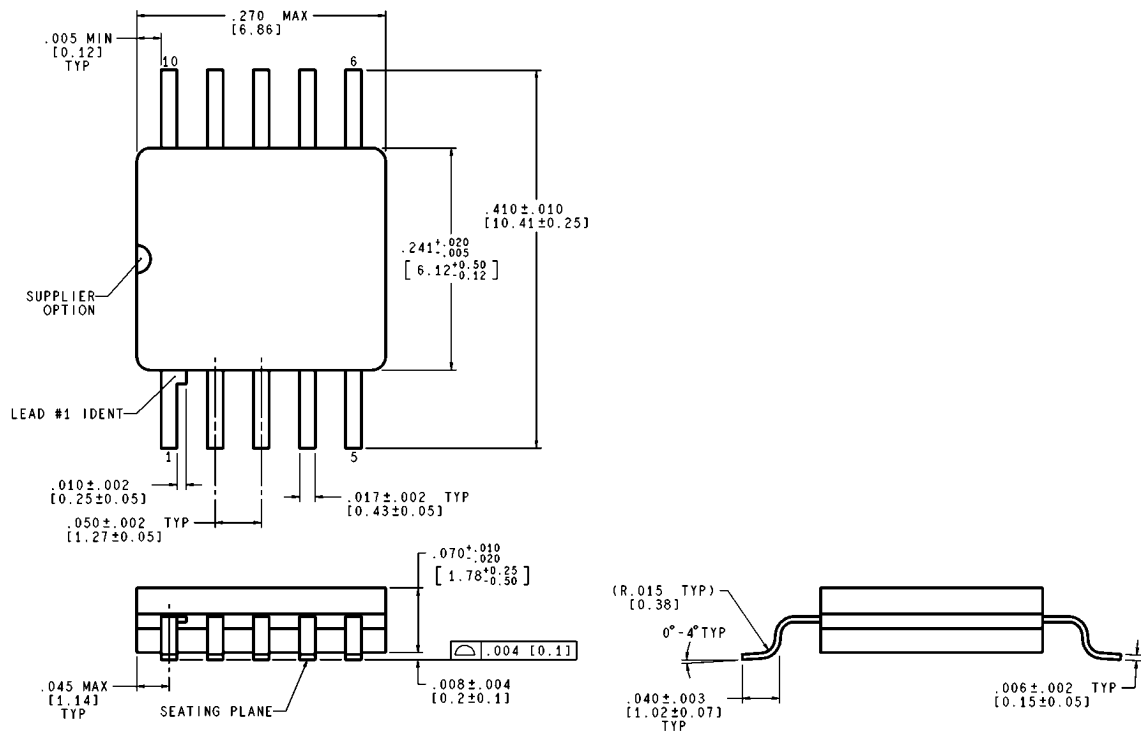

CONTROLLING DIMENSION IS INCH
VALUES IN [] ARE MILLIMETERS

WG10A (Rev C)

**10-Pin Ceramic SOIC
NS Package Number WG10A**

Notes

THE CONTENTS OF THIS DOCUMENT ARE PROVIDED IN CONNECTION WITH NATIONAL SEMICONDUCTOR CORPORATION ("NATIONAL") PRODUCTS. NATIONAL MAKES NO REPRESENTATIONS OR WARRANTIES WITH RESPECT TO THE ACCURACY OR COMPLETENESS OF THE CONTENTS OF THIS PUBLICATION AND RESERVES THE RIGHT TO MAKE CHANGES TO SPECIFICATIONS AND PRODUCT DESCRIPTIONS AT ANY TIME WITHOUT NOTICE. NO LICENSE, WHETHER EXPRESS, IMPLIED, ARISING BY ESTOPPEL OR OTHERWISE, TO ANY INTELLECTUAL PROPERTY RIGHTS IS GRANTED BY THIS DOCUMENT.

TESTING AND OTHER QUALITY CONTROLS ARE USED TO THE EXTENT NATIONAL DEEMS NECESSARY TO SUPPORT NATIONAL'S PRODUCT WARRANTY. EXCEPT WHERE MANDATED BY GOVERNMENT REQUIREMENTS, TESTING OF ALL PARAMETERS OF EACH PRODUCT IS NOT NECESSARILY PERFORMED. NATIONAL ASSUMES NO LIABILITY FOR APPLICATIONS ASSISTANCE OR BUYER PRODUCT DESIGN. BUYERS ARE RESPONSIBLE FOR THEIR PRODUCTS AND APPLICATIONS USING NATIONAL COMPONENTS. PRIOR TO USING OR DISTRIBUTING ANY PRODUCTS THAT INCLUDE NATIONAL COMPONENTS, BUYERS SHOULD PROVIDE ADEQUATE DESIGN, TESTING AND OPERATING SAFEGUARDS.

EXCEPT AS PROVIDED IN NATIONAL'S TERMS AND CONDITIONS OF SALE FOR SUCH PRODUCTS, NATIONAL ASSUMES NO LIABILITY WHATSOEVER, AND NATIONAL DISCLAIMS ANY EXPRESS OR IMPLIED WARRANTY RELATING TO THE SALE AND/OR USE OF NATIONAL PRODUCTS INCLUDING LIABILITY OR WARRANTIES RELATING TO FITNESS FOR A PARTICULAR PURPOSE, MERCHANTABILITY, OR INFRINGEMENT OF ANY PATENT, COPYRIGHT OR OTHER INTELLECTUAL PROPERTY RIGHT.

LIFE SUPPORT POLICY

NATIONAL'S PRODUCTS ARE NOT AUTHORIZED FOR USE AS CRITICAL COMPONENTS IN LIFE SUPPORT DEVICES OR SYSTEMS WITHOUT THE EXPRESS PRIOR WRITTEN APPROVAL OF THE CHIEF EXECUTIVE OFFICER AND GENERAL COUNSEL OF NATIONAL SEMICONDUCTOR CORPORATION. As used herein:

Life support devices or systems are devices which (a) are intended for surgical implant into the body, or (b) support or sustain life and whose failure to perform when properly used in accordance with instructions for use provided in the labeling can be reasonably expected to result in a significant injury to the user. A critical component is any component in a life support device or system whose failure to perform can be reasonably expected to cause the failure of the life support device or system or to affect its safety or effectiveness.

National Semiconductor and the National Semiconductor logo are registered trademarks of National Semiconductor Corporation. All other brand or product names may be trademarks or registered trademarks of their respective holders.

Copyright© 2007 National Semiconductor Corporation

For the most current product information visit us at www.national.com



**National Semiconductor
Americas Customer
Support Center**
Email:
new.feedback@nsc.com
Tel: 1-800-272-9959

**National Semiconductor Europe
Customer Support Center**
Fax: +49 (0) 180-530-85-86
Email: europe.support@nsc.com
Deutsch Tel: +49 (0) 69 9508 6208
English Tel: +49 (0) 870 24 0 2171
Français Tel: +33 (0) 1 41 91 8790

**National Semiconductor Asia
Pacific Customer Support Center**
Email: ap.support@nsc.com

**National Semiconductor Japan
Customer Support Center**
Fax: 81-3-5639-7507
Email: jpn.feedback@nsc.com
Tel: 81-3-5639-7560