

## LMV1022/LMV1023

# PDM Output Pre-Amplifier for Electret Microphones

### General Description

The LMV1022 and LMV1023 integrate a pre-amplifier and ADC that can be mounted inside an electret condenser microphone (ECM). The digital output signal is a pulse density modulation (PDM) bitstream that allows the microphone to connect directly to the DSP or baseband processor.

Part of National Semiconductor's Powerwise™ family of products, the LMV1022/LMV1023 consume 900µW of power during operation, offering significant power savings over an analog microphone with an external ADC. The LMV1022 outputs its data on the rising clock edge. The LMV1023 outputs its data on the falling clock edge. Both devices can share the same clock and data lines to create a 4-wire stereo solution. The external clock frequency sets the audio pass band frequency. An 800kHz clock sets the pass band to 7kHz. A 2.4MHz clock sets the pass band to 20kHz.

The LMV1022 and LMV1023 are available in 6-bump micro SMD packages with 1kg adhesion properties.

### Key Specifications

(Typical  $V_{DD} = 1.8V$ ,  $CLOCK = 1.2MHz$ ,  $f_{INPUT} = 1kHz$ ,  $V_{INPUT} = 18mV_{PP}$ , unless otherwise specified)

■ SNR A-weighted	61dB
■ Analog A-weighted noise floor	$5 \mu V_{RMS}$
■ Supply current	0.5mA
■ Total harmonic distortion	0.05%
■ Power supply rejection ratio	87dB

### Features

- Integrated 21 dB Pre-Amp and ADC for significant power and space savings
- Integrated high-pass Filter to reduce 'Plop Noise'
- Excellent RF immunity (e.g. buzz noise)
- LMV1022 and LMV1023 combine to create 4-wire Stereo Solution
- Very thin 0.35mm micro SMD packaging
- Adhesion technology >1kg

### Applications

- Digital audio subsystems and stereo arrays
- Electret condenser microphones with all digital output
- Portable communications and small form factor devices
- Digital audio computing or voice security
- Automotive or array systems
- Headphone and headset accessories

### Typical Application

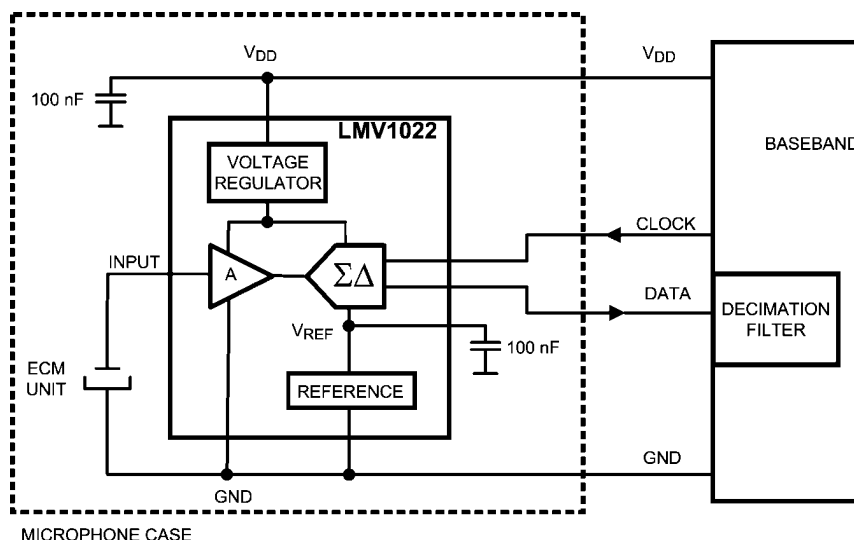

20212475

For a stereo application, see *STEREO OPERATION* in the Application Section.

## Connection Diagram

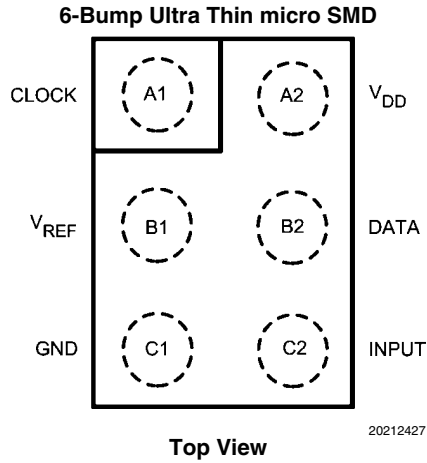

## Pin Descriptions

	Pin	Name	Description
Power Supply	A2	$V_{DD}$	Positive supply voltage
	C1	GND	Ground
Input	C2	Input	The microphone is connected to this input pin.
Reference	B1	$V_{REF}$	A capacitor of 100nF is connected between $V_{REF}$ and ground. This capacitor is used to filter the internal converter reference voltage.
Clock Input	A1	Clock	The user adjustable clock frequency ranges from 800kHz to 2.4MHz.
Data Output	B2	Data	Over sampled bitstream output. Data is valid if clock is LOW (LMV1022). The data of the LMV1023 is valid when clock is HIGH. When the data is not valid the data output is high impedance. For exact specifications see application section.

## Ordering Information

Package	Part Number	Package Marking	Transport Media	NSC Drawing
6-Bump Ultra Thin micro SMD lead free only	LMV1022UR	Z	250 Units Tape and Reel	URA06GGA
	LMV1022URX		3k Units Tape and Reel	
	LMV1023UR	1	250 Units Tape and Reel	
	LMV1023URX		3k Units Tape and Reel	

**Absolute Maximum Ratings** (Note 1)

If Military/Aerospace specified devices are required, please contact the National Semiconductor Sales Office/Distributors for availability and specifications.

Supply Voltage	3.8V
ESD Rating (Note 4)	2000V
ESD Rating (Note 5)	200V
Storage Temperature Range	-65°C to 150°C
Junction Temperature $T_{JMAX}$ (Note 3)	150°C max

Mounting Temperature

Infrared or Convection (20 sec.)

235°C

**Operating Ratings** (Note 2)

Supply Voltage(Note 2)	1.6V to 3.6V
Input Clock Frequency	800kHz to 2.4MHz
Duty Cycle	40% to 60%
Operating Temperature Range	-40°C to 85°C

**1.8V Electrical Characteristics** (Note 2)

Unless otherwise specified, all limits are guaranteed for  $T_J = 25^\circ\text{C}$ ,  $V_{DD} = 1.8\text{V}$ ,  $V_{IN} = 18\text{mV}_{PP}$ ,  $f_{CLK} = 1.2\text{MHz}$ , Duty Cycle = 50% and 100nF capacitor between  $V_{REF}$  and GND.

Symbol	Parameter	Conditions	LMV1022/ LMV1023		Units (Limits)
			Typical (Note 6)	Limit (Note 7)	
SNR	Signal to Noise Ratio	$f_{IN} = 1\text{kHz}$ , A-Weighted, output = -23.5dBFS	61	56	dB (min)
$e_{ND}$	Digital Noise floor of the ADC (Integrated)	Bandwidth = 10 kHz Non Weighted (Note 9)	-96		dBFS
$e_{NA}$	Noise Floor (Input Referred)	Electrical A-Weighted	5		$\mu\text{V}_{RMS}$
		Acoustic A-Weighted (Note 10)	-32		dB SPL
DR	Dynamic range		85	80	dB (min)
THD	Total Harmonic Distortion	$f_{IN} = 1\text{kHz}$ , $V_{IN} = 18\text{mV}_{PP}$	0.05		%
THD+N	Total Harmonic Distortion and Noise	$f_{IN} = 1\text{kHz}$ , $V_{IN} = 18\text{mV}_{PP}$ A-Weighted	0.1		
PSRR	Power Supply Rejection Ratio	$V_{IN} = \text{GND}$ , Test Signal on $V_{DD}$ , 217Hz, $400\text{mV}_{PP}$ Input referred.	87		dB
$V_{IN}$	Max Input Signal	$f_{IN} = 1\text{kHz}$ , THD < 1%	150		$\text{mV}_{PP}$
	Acoustic Overload Point	$f_{IN} = 1\text{kHz}$ , THD < 10% (Note 10)	115		dB SPL
$VD_{OUT}$	Max Digital Output level	$f_{IN} = 1\text{kHz}$ , THD < 1%	-5		dBFS
	Acoustic Overload Point	$f_{IN} = 1\text{kHz}$ , THD < 10% (Note 10)	-3		
$f_{LOW}$	Lower -3dB Corner Frequency	$F_{CLK} = 1.2\text{MHz}$	17		Hz
		$F_{CLK} = 2.4\text{MHz}$	33		Hz
$C_{IN}$	Input Capacitance		2		pF
$R_{IN}$	Input Impedance	$V_{IN} = 0V_{DC}$	>1000		$M\Omega$
$I_{DD}$	Supply Current	$V_{IN} = \text{GND}$ , CLK = ON, High Impedance Load	0.5	0.75	mA (max)
		$V_{IN} = \text{GND}$ , CLK = OFF, High Impedance Load	0.45	0.6	mA (max)

### 3.3V Electrical Characteristics (Note 2)

Unless otherwise specified, all limits are guaranteed for  $T_J = 25^\circ\text{C}$ ,  $V_{DD} = 3.3\text{V}$ ,  $V_{IN} = 18\text{mV}_{PP}$ ,  $f_{CLK} = 2.4\text{MHz}$ , Duty Cycle = 50% and 100nF capacitor between  $V_{REF}$  and GND.

Symbol	Parameter	Conditions	LMV1022/ LMV1023		Units (Limits)
			Typical (Note 6)	Limit (Note 7)	
SNR	Signal to Noise Ratio	$f_{IN} = 1\text{kHz}$ , A-Weighted, output = -23.5dBFS	61	56	dB (min)
$e_{ND}$	Digital Noise floor of the ADC (Integrated)	Bandwidth = 20 kHz Non Weighted (Note 9)	-96		dBFS
$e_{NA}$	Noise Floor (Input Referred)	Electrical A-Weighted	5		$\mu\text{V}_{RMS}$
		Acoustic A-Weighted (Note 10)	-32		dB SPL
DR	Dynamic range		85	80	dB (max)
THD	Total Harmonic Distortion	$f_{IN} = 1\text{kHz}$ , $V_{IN} = 18\text{mV}_{PP}$	0.05		%
THD+N	Total Harmonic Distortion and Noise	$f_{IN} = 1\text{kHz}$ , $V_{IN} = 18\text{mV}_{PP}$ A-Weighted	0.1		
PSRR	Power Supply Rejection Ratio	$V_{IN} = \text{GND}$ , Test Signal on $V_{DD}$ , 217Hz, $400\text{mV}_{PP}$ Input referred.	87		dB
$V_{IN}$	Max Input Signal	$f_{IN} = 1\text{kHz}$ , THD < 1%	150		$\text{mV}_{PP}$
	Acoustic Overload Point	$f_{IN} = 1\text{kHz}$ , THD < 10% (Note 10)	115		dB SPL
$V_{DOUT}$	Max Digital Output level	$f_{IN} = 1\text{kHz}$ , THD < 1%	-5		dBFS
	Acoustic Overload Point	$f_{IN} = 1\text{kHz}$ , THD < 10% (Note 10)	-3		
$f_{LOW}$	Lower -3dB Corner Frequency	$F_{CLK} = 1.2\text{MHz}$	17		Hz
		$F_{CLK} = 2.4\text{MHz}$	33		Hz
$C_{IN}$	Input Capacitance		2		pF
$R_{IN}$	Input Impedance	$V_{IN} = 0V_{DC}$	>1000		$\text{M}\Omega$
$I_{DD}$	Supply Current	$V_{IN} = \text{GND}$ , CLK = ON, High Impedance Load	0.6	0.9	mA (max)
		$V_{IN} = \text{GND}$ , CLK = OFF, High Impedance Load	0.5	0.65	mA (max)

## Digital Interface Electrical Characteristics

Unless otherwise specified, all limits are guaranteed for  $T_J = 25^\circ\text{C}$ ,  $1.6\text{V} < V_{DD} < 3.6\text{V}$ ,  $V_{IN} = 18\text{ mV}_{PP}$ ,  $800\text{kHz} < f_{CLK} < 2.4\text{ MHz}$ , Duty Cycle = 50% and 100nF capacitor between  $V_{REF}$  and GND.

Symbol	Parameter	Conditions	Typical (Note 6)	Limits (Note 7)	Units (min/max)
$V_{LOW}$	CLOCK Logic Low Level			$0.1 \cdot V_{DD}$	V (max)
$V_{HIGH}$	CLOCK Logic High Level			$0.9 \cdot V_{DD}$	V (min)
$V_{OL}$	DATA Output Logic Low Level	$I_{SINK} = 0.5\text{mA}$		0.1	V (min)
$V_{OH}$	DATA Output Logic High Level	$I_{SOURCE} = 0.5\text{mA}$		$V_{DD} - 0.1\text{V}$	V (max)
$t_{HZ}$	Time from CLOCK Transition to DATA Becoming High Impedance (See also <i>Figure 10</i> , Application Section)	LMV1022: On Rising Edge of the CLOCK	65		ns
		LMV1023: On Falling Edge of the CLOCK			
$t_{DV}$	Time from CLOCK Transition to DATA Becoming Valid (See also <i>Figure 10</i> , Application Section)	LMV1022: On Falling Edge of the CLOCK	90		ns
		LMV1023: On Rising Edge of the CLOCK			

**Note 1:** "Absolute Maximum Ratings" indicate limits beyond which damage to the device may occur, including inoperability and degradation of device reliability and/or performance. Functional operation of the device and/or non-degradation at the *Absolute Maximum Ratings* or other conditions beyond those indicated in the *Recommended Operating Conditions* is not implied. The *Recommended Operating Conditions* indicate conditions at which the device is functional and the device should not be operated beyond such conditions. All voltages are measured with respect to the ground pin, unless otherwise specified.

**Note 2:** The Electrical Characteristics tables list guaranteed specifications under the listed Recommended Operating Conditions except as otherwise modified or specified by the Electrical Characteristics Conditions and/or Notes. Typical specifications are estimations only and are not guaranteed.

**Note 3:** The maximum power dissipation must be derated at elevated temperatures and is dictated by  $T_{JMAX}$ ,  $\theta_{JA}$ , and the ambient temperature,  $T_A$ . The maximum allowable power dissipation is  $P_{DMAX} = (T_{JMAX} - T_A) / \theta_{JA}$  or the number given in Absolute Maximum Ratings, whichever is lower. For the LMV1022, LM1023 see power derating curves for additional information.

**Note 4:** Human body model, applicable std. JESD22-A114C.

**Note 5:** Machine model, applicable std. JESD22-A115-A.

**Note 6:** Typical values represent most likely parametric norms at  $T_A = +25^\circ\text{C}$ , and at the Recommended Operation Conditions at the time of product characterization and are not guaranteed.

**Note 7:** Datasheet min/max specification limits are guaranteed by test or statistical analysis.

**Note 8:** The Supply Current depends on the applied Clock Frequency and the load on the DATA output.

**Note 9:** Quantization Noise level of the modulator (verified by simulation)

**Note 10:** Calculated for Typical microphone as described in the Application section *Digital Microphone*

### Typical Performance Characteristics

Unless otherwise specified, measurements are performed on an LMV1022/ LMV1023 with  $V_{DD} = 1.8V$ , Clock Duty Cycle = 50% and a 100nF capacitor is placed between  $V_{REF}$  and GND,  $T_J = 25^\circ C$ ,  $V_{in} = 18 mV_{pp}$

**Output Spectrum at 16kBit/s, CLOCK Frequency = 0.8MHz**

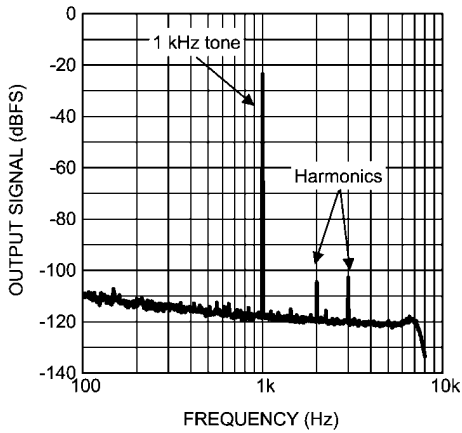

20212446

**Output Spectrum at 48kbit/s, CLOCK Frequency = 2.4MHz**

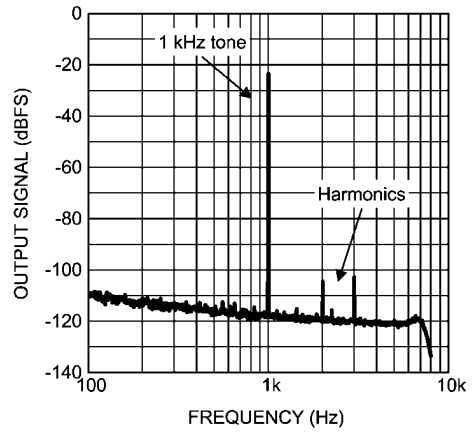

20212430

**Output Spectrum, Stereo Operation at 48kbit/s, CLOCK Frequency = 2.4MHz**

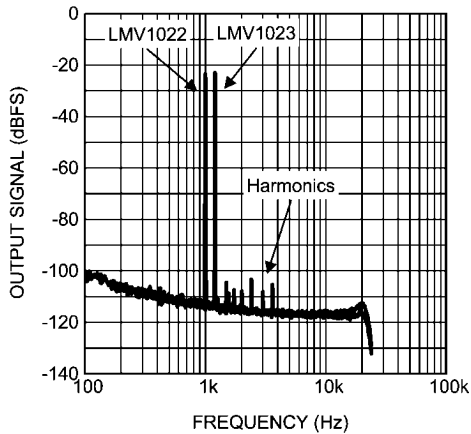

20212431

**Output Noise Spectrum at 16kbit/s and 48kbit/s**

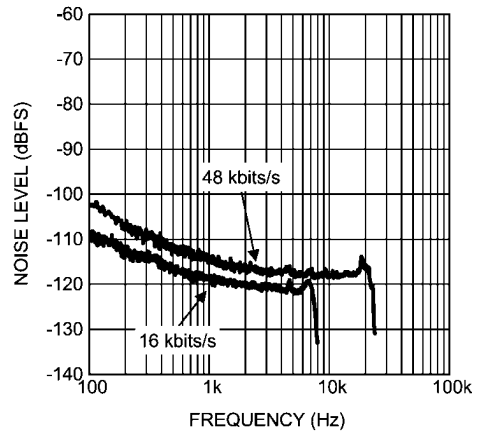

20212448

**THD and Output Level vs. Frequency at 16bBit/s, CLOCK Frequency = 0.8MHz**  
 $V_{in} = 50mV_{pp}$

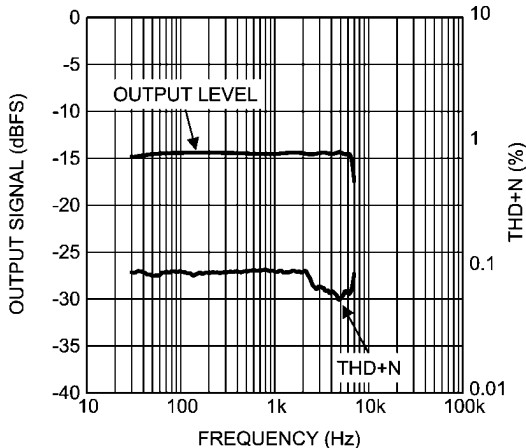

20212449

**THD and Output Level vs. Frequency at 24kbit/s, CLOCK Frequency = 1.2MHz**  
 $V_{in} = 50mV_{pp}$

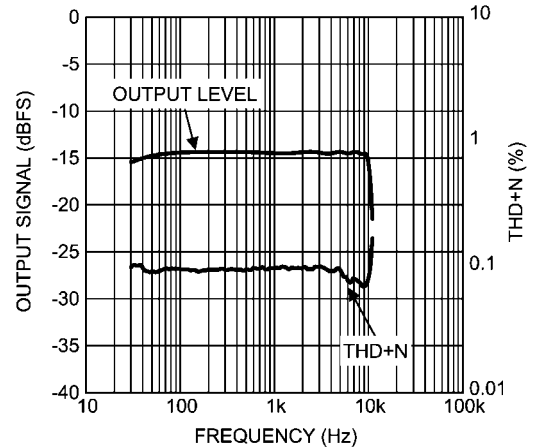

20212450

**THD and Output Level vs. Frequency**  
 at 32kbit/s, CLOCK Frequency = 1.6MHz  
 $V_{in} = 50mV_{pp}$

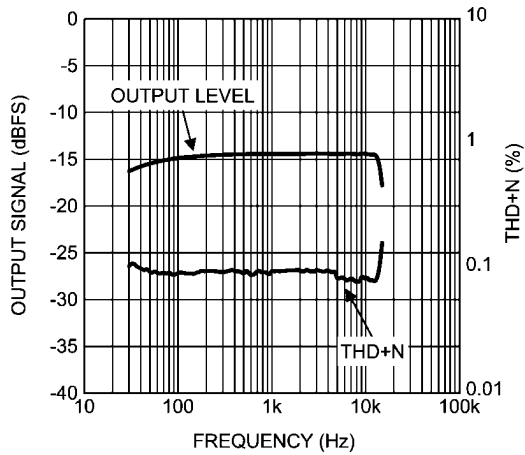

20212432

**THD and Output Level vs. Frequency**  
 at 48kbit/s, CLOCK Frequency = 2.4MHz  
 $V_{in} = 50mV_{pp}$

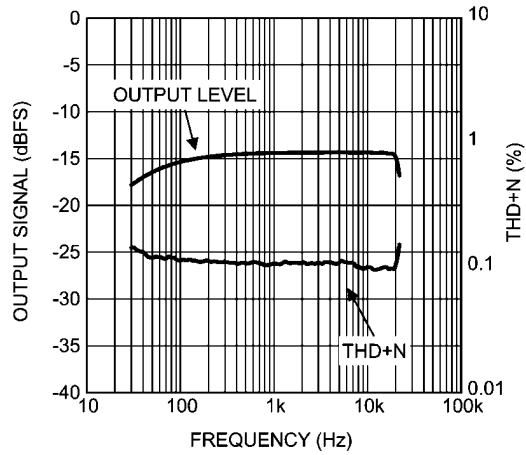

20212452

**THD vs. Input Level**  
 at 16kbit/s, CLOCK Frequency = 0.8MHz

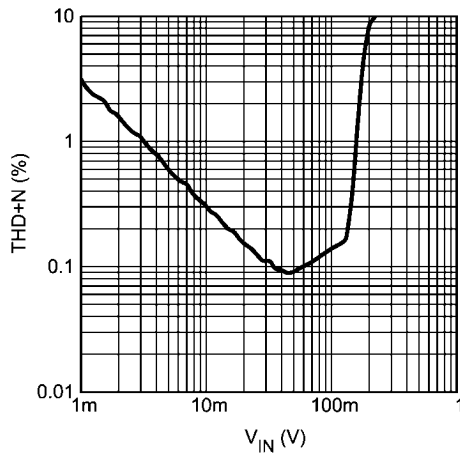

20212453

**THD vs. Input Level**  
 at 24kbit/s, CLOCK Frequency = 1.6MHz

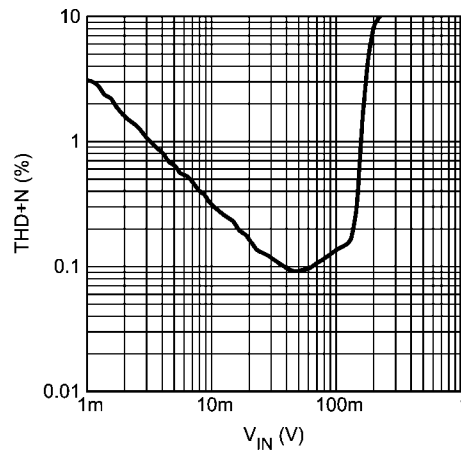

20212454

**THD vs. Input Level**  
 at 32kbit/s, CLOCK Frequency = 1.6MHz

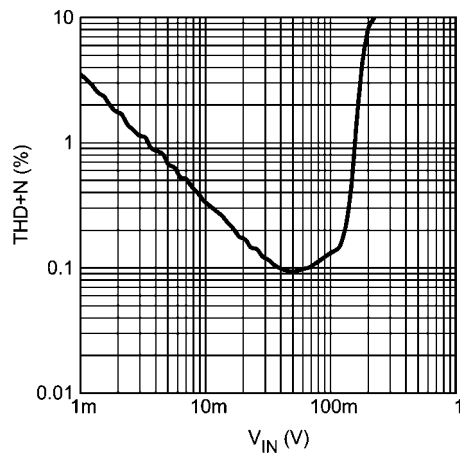

20212433

**THD vs. Input Level**  
 at 48kbit/s, CLOCK Frequency = 2.4MHz

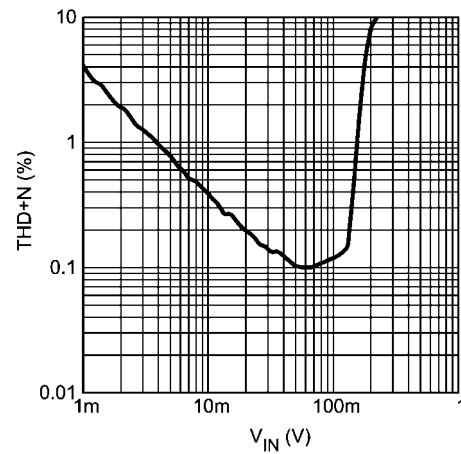

20212456

**PSRR vs. Frequency for  $V_{DD} = 1.8V$  and  $3.3V$   
at 16kbit/s, CLOCK Frequency = 0.8MHz**

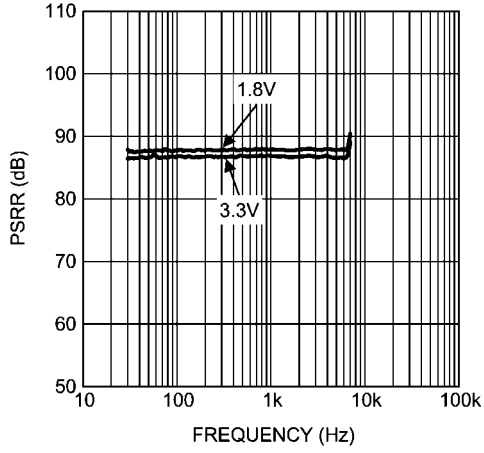

20212457

**PSRR vs. Frequency for  $V_{DD} = 1.8V$  and  $3.3V$   
at 48kbit/s, CLOCK Frequency = 2.4MHz**

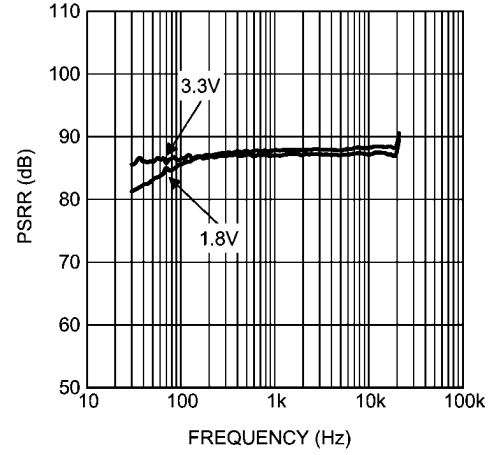

20212458

**$I_{DD}$  vs.  $V_{DD}$   
CLOCK Frequency = 0.8MHz and 2.4MHz**

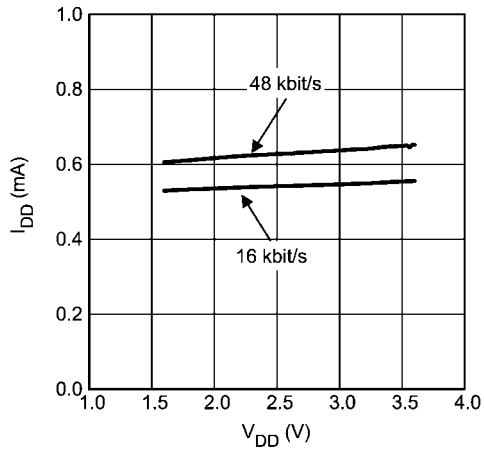

20212434

## Application Section

The LMV1022 and LMV1023 consist of a pre-amplifier and sigma-delta converter for placement inside an electret condenser microphone (ECM). The output of the LMV1022/LMV1023 is a robust digital serial bit stream eliminating the sensitive low-level analog signals of conventional JFET microphones. This application section describes, among others, a typical application, a sensitivity comparison between different ECM types, stereo operation and layout recommendations on the ECM PCBs.

### TYPICAL APPLICATION

Figure 1 depicts a typical application, where the LMV1022 or LMV1023 is built inside the ECM canister. This ECM can be directly connected to a DSP in a digital audio system, like a baseband chip in a cell phone. Connecting is easy because of the digital LMV1022/ LMV1023 interface. A digital filter in the DSP or Baseband decimates the audio signal.

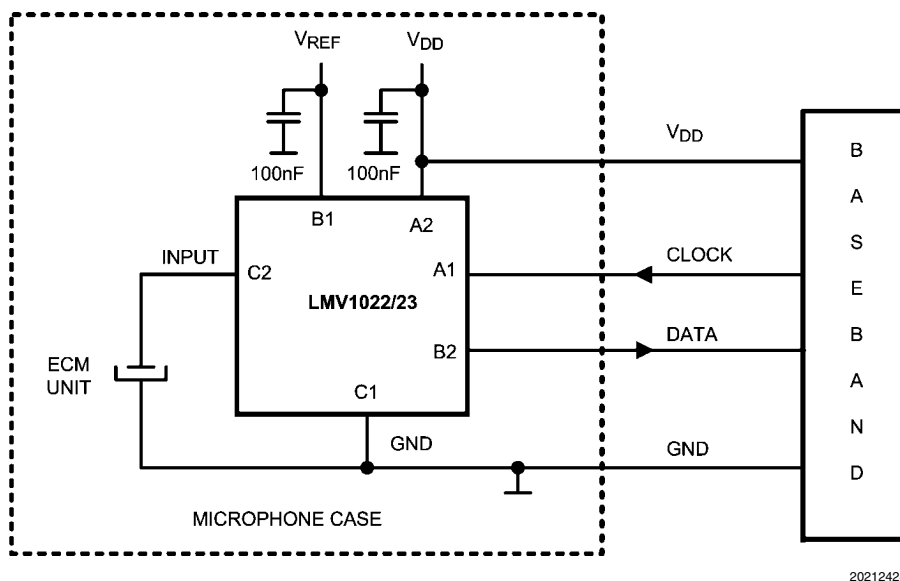

FIGURE 1. Typical Application

### LOW FREQUENCY CUT OFF FILTER

To reduce noise on the output of the microphone a low frequency cut off filter has been implemented. This filter reduces the effect of wind and handling noise. It's also helpful to reduce the proximity effect in directional microphones. This effect occurs when the sound source is very close to the microphone. The air pressure wave results in very low frequency, large amplitude signals that when amplified gives a 'plop' sound. This large signal can cause a temporary overload in the amplifier, which results in distortion of the signal. The corner frequency of the integrated high pass filter is linear proportional to the input clock frequency of the part.

### BUILT-IN PRE-AMPLIFIER / ADC

The LMV1022/ LMV1023 are offered in a space saving small 6-bump micro SMD package in order to fit inside small ECM canisters. The LMV1022 or LMV1023 IC is placed on the PCB. This PCB forms the bottom of the microphone, which is placed in the device.

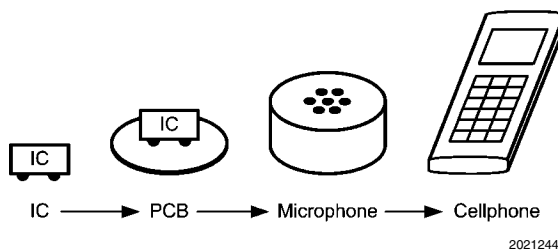
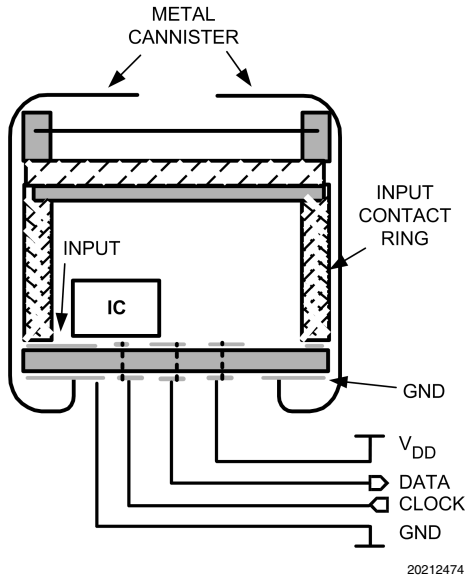

FIGURE 2. Built-in Pre-Amplifier / ADC

Figure 3 depicts a cross section of a microphone with the IC inside the ECM canister. The PCB of the microphone has 4 pads that connects  $V_{DD}$ , Ground, DATA and the CLOCK.



**FIGURE 3. Cross section of a Microphone**

**A-WEIGHTED FILTER**

The human ear has a frequency range from about 20Hz to 20kHz. Within this range the sensitivity of the human ear is not equal for each frequency. In order to approach a natural hearing response, weighting filters are introduced. One of these filters is the A-weighted filter. The A-weighted filter is commonly used in signal-to-noise ratio measurements, where sound is compared to device noise. The filter improves the correlation of the measured data to the signal-to-noise ratio perceived by the human ear.

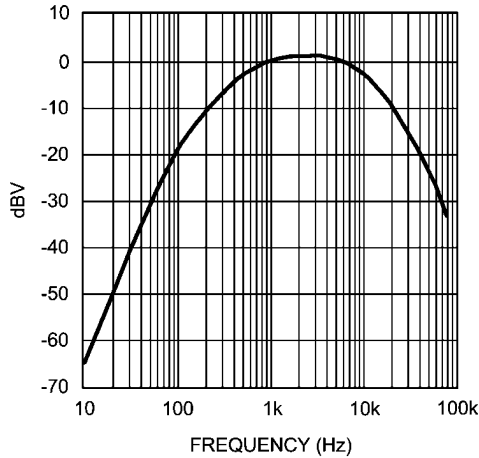

20212440

**FIGURE 4. A-weighted Filter**

**SENSITIVITY**

Sensitivity is a measure for the transfer from the applied acoustic signal to the output of the microphone. Conventional JFET microphones and microphones with built-in gain have a sensitivity that is expressed in dB(V/Pa), where 0dB = 1V/Pa. A certain pressure on the electret of the microphone gives a certain voltage at the output of the microphone. Because a microphone using the LMV1022/ LMV1023 has a digital output, the sensitivity will be stated in dB(Full Scale/Pascal) or dB(FS/Pa) as opposed to conventional microphones. This section compares the various microphone types and their sensitivity. Examples are given to calculate the resulting output for a given sound pressure.

**Sound Pressure Level**

The volume of sound applied to a microphone is usually stated as a sound pressure in dB SPL. This unity of dB SPL refers to the threshold of hearing of the human ear. The sound pressure in decibels is defined by:

$$SPL = 20 \log (P_M/P_O)$$

Where,

SPL is the Sound Pressure in dB SPL

$P_M$  is the measured absolute sound pressure in Pa

$P_O$  is the threshold of hearing (20µPa)

In order to calculate the resulting output voltage of the electret element for a given sound pressure in dB SPL, the absolute sound pressure  $P_M$  must be known. This is the absolute sound pressure in decibels referred to 1Pa instead of 20µPa.

The absolute sound pressure  $P_M$  in dBPa is given by:

$$P_M = SPL \text{ (dB SPL)} + P_O \text{ (dBPa)}$$

$$P_M = SPL + 20 \cdot \log 20\mu Pa$$

$$P_M = SPL - 94dB$$

**JFET Microphone**

Translation from the absolute sound pressure level to a voltage can be done when the electrets sensitivity is known. A typical electret element has a sensitivity of -44dB(V/Pa). This is also the typical sensitivity number for the JFET microphone, since a JFET usually has a gain of about 1x (0dB). A block diagram of a microphone with a JFET is given in Figure 5.

Example: Busy traffic has a sound pressure of 70dB SPL.

$$\text{Microphone Output} = SPL + C + S$$

Where,

SPL is the Sound Pressure in dB SPL

C is the dB SPL to dBPa conversion (-94dB)

S is the Sensitivity in dB(V/Pa)

$$\text{Microphone Output} = 70 - 94 - 44 = -68dBV$$

This is equivalent to 1.13mV<sub>pp</sub>.

The analog output signal is so low that it can easily be distorted by interference from outside the microphone. Additional gain is desirable to make the signal less sensitive to interference.

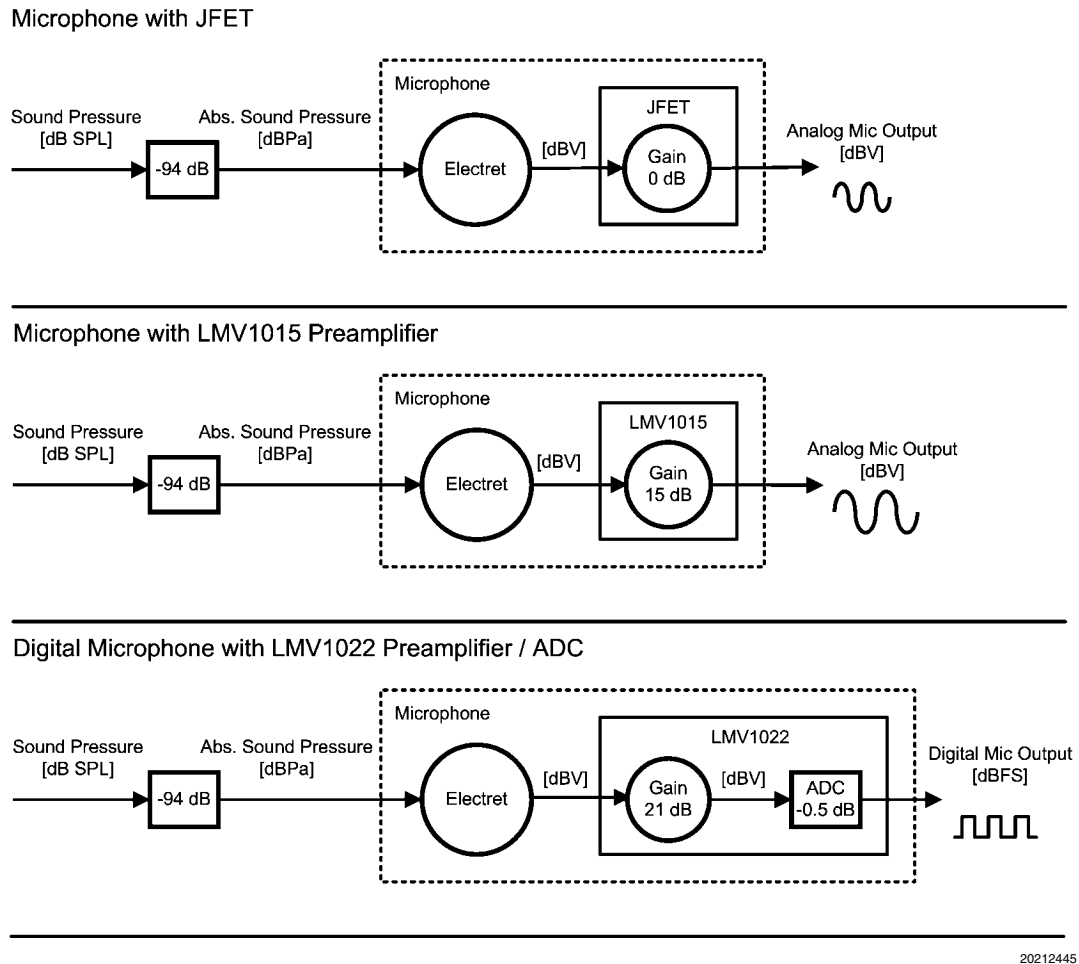

20212445

FIGURE 5. Microphone Sensitivity

### Microphone with Additional Gain

When gain is added to the electret element, the analog signal becomes larger and therefore more robust. This can be accomplished by using a pre-amplifier with a higher gain than the JFET. The sensitivity of the microphone consists of the sensitivity of the electret plus the gain of the pre-amplifier. When choosing National Semiconductor's LMV1015-15 for instance, a gain of 15dB is added by the pre-amplifier. This results in a sensitivity of  $-29\text{dB(V/Pa)}$  with a typical electret element of  $-44\text{dB(V/Pa)}$ . National Semiconductor has a wide range of pre-amplifiers with different gain factors, which can be used to replace the JFET inside the microphone canister. Please visit [www.national.com](http://www.national.com) for more information on the LMV1015 and LMV1032 pre-amplifier series. A block diagram with the LMV1015 pre-amplifier inside an ECM is given in Figure 5.

When taking the same example of busy traffic (70dB SPL), the output voltage of the microphone with the LMV1015 is:

$$\text{Microphone Output} = \text{SP} + \text{C} + \text{S}$$

Where,

SP is the Sound Pressure in dB SPL

C is the dB SPL to dBPa conversion ( $-94\text{dB}$ )

S is the Sensitivity in dB(V/Pa)

$$\text{Microphone output} = 70 - 94 - 29 = -53\text{dBV.}$$

This is equivalent to  $6.33\text{mV}_{\text{PP}}$ .

The pre-amplifier with additional gain reduces the impact of noise on the wiring and traces from the microphone to the baseband chip significantly. To reduce interference further, an Analog-to-Digital converter is integrated in both the LMV1022 and LMV1023, realizing a digital interface between the microphone and the baseband.

### Digital Microphone

By integrating the Analog-to-Digital converter (ADC) in the LMV1022/ LMV1023 all analog signals are kept within the "shielded" microphone canister. The output is a digital interface that is robust and insensitive to interference and noise from outside the canister. The output is expressed in dBFS and therefore the sensitivity is also stated in dB(FS/Pa) instead of dB(V/Pa). To calculate the digital output (Data) in dBFS the following equation can be written for the LMV1022/ LMV1023:

$$\text{Digital Output} = 10 \text{ LOG} \left[ \frac{P_{\text{INPUT}}}{P_{\text{REF}}} \right] + A \quad (1)$$

Where,

$P_{\text{REF}}$  is the reference power, which is defined as the maximum allowed input power (Full Scale).  $P_{\text{INPUT}}$  is the applied power

on the input pin and “A” is the gain of the pre-amplifier in decibels.

Written into voltages, the equation is:

$$\text{Digital Output} = 20 \text{ LOG} \left[ \frac{V_{\text{INPUT}}}{V_{\text{REF}}} \right] + A \quad (2)$$

Or in decibels:

$$\text{Digital Output (dBFS)} = \text{Input (dBV)} - \text{Reference (dB)} + A$$

Where,

$$\text{Input} = 20 \text{ Log } V_{\text{INPUT}} (V_{\text{RMS}})$$

$$\text{Ref} = 20 \text{ Log } V_{\text{REF}} (V_{\text{RMS}})$$

A is the Gain (dB)

For the LMV1022/ LMV1023 the reference voltage  $V_{\text{REF}}$  is  $1.5V_P$  ( $1.06 V_{\text{RMS}}$ ) and the Gain A is 21dB. These parameters are fixed inside the device. Knowing this, Equation 2 can be simplified:

$$\text{Digital Output (dBFS)} = V_{\text{INPUT}} (\text{dBV}) - 0.5 + 21$$

$$\text{Digital Output (dBFS)} = V_{\text{INPUT}} (\text{dBV}) + 20.5$$

The sensitivity of the digital microphone is the sensitivity of a conventional microphone plus the input to output transfer of the LMV1022/ LMV1023. The sensitivity of a typical digital microphone is therefore:  $-44 + 20.5 = -23.5\text{dB}(\text{FS}/\text{Pa})$ .

$$\text{Digital Output} = \text{SP} + \text{C} + \text{S}$$

Where,

SP is the Sound Pressure in dB SPL

C is the dB SPL to dBPa conversion (-94dB)

S is the Sensitivity in dB(V/Pa)

Taking the example of busy traffic (70 dB SPL) again results in the following digital output (dBFS):

$$\text{Digital Output (dBFS)} = \text{SP} - \text{C} + \text{S}$$

$$\text{Digital Output (dBFS)} = 70 - 94 - 23.5 = -47.5\text{dBFS}$$

### ANALOG-TO-DIGITAL CONVERTER

The ADC used in the LMV1022/ LMV1023 is an one bit sigma-delta converter with a Pulse Density Modulated output signal (PDM). The output of this ADC can be either High (one) or Low (zero). Assume that the LMV1022/ LMV1023 input is at the minimum level. In that case the DATA output will produce almost only “zeros”. When the input increases, the amount of “ones” increases too. At mid-point, where the input is 0V, the number of “zeros” will equal the number of “ones”. At the time that the input approaches the maximum level, the DATA output produces a majority of “ones”. Figure 6 shows the resulting DATA output as function of the input.

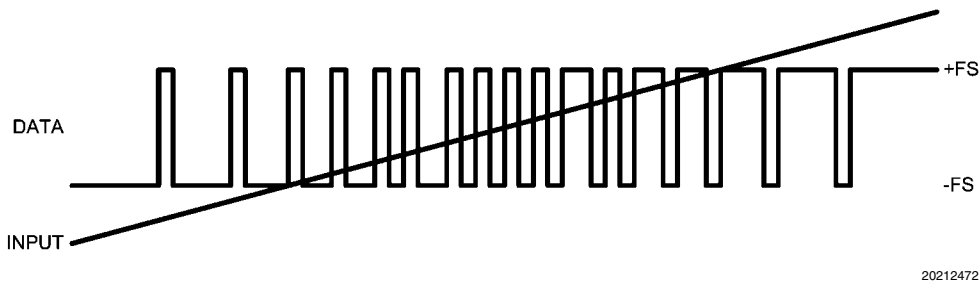

FIGURE 6. DATA Output versus Input Amplitude

An important characteristic of the sigma-delta converter is that the noise is shifted out of the band of interest to frequencies above the band of interest. The band that can be used (Audio Bandwidth) relates directly the applied clock frequency. Table 1 shows the relation between the Clock Frequency and a couple of common Audio Bandwidths.

TABLE 1. Audio Bandwidth vs. Clock Frequency

Clock Frequency (MHz)	Sample Rate after Decimation (kbit/s)	Audio Bandwidth (kHz)
0.8	16	7
1.2	24	10
1.6	32	14
2.4	48	20

The high corner of the band of interest (knee) is determined by the clock frequency divided by 2 times the Over Sampling Ratio (OSR). The factor of two comes from the Nyquist theorem. The OSR of this particular ADC is chosen at 60. This sets the high corner of the band at the clock frequency divided by 120. For instance when a bandwidth of 10kHz is desired, the clock frequency needs to be 1.2MHz or higher. Figure 7 depicts the noise shaping effect in a frequency spectrum plot, where a 1 kHz signal is applied.

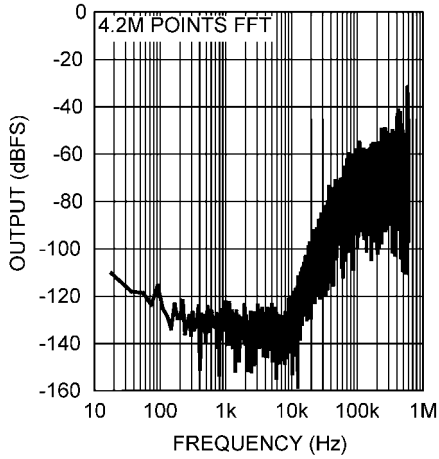

20212461

**FIGURE 7. Frequency Spectrum**

A low-pass decimation filter implemented in the baseband chip or DSP eliminates the noise above the band of interest. The resulting frequency spectrum contains only the frequency components left within the band of interest. *Figure 8* depicts the frequency spectrum after filtering.

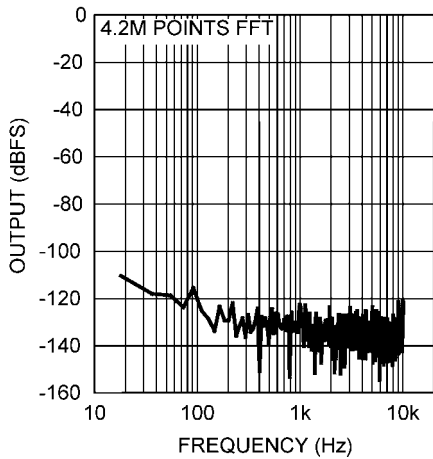

20212473

**FIGURE 8. Frequency Spectrum after Filtering**

**STEREO OPERATION**

The LMV1022 and the LMV1023 are designed to operate together in a stereo solution with two microphones. One micro-

phone will have a LMV1022 built-in and the other will have a LMV1023 built-in. These two microphones share the same interface lines to minimize wiring (*Figure 9*).

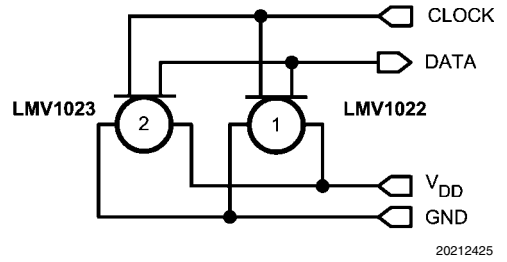

20212425

**FIGURE 9. Stereo Application**

Both microphones produce valid data in only one half of a clock cycle to allow the two microphones to operate on the same I/O lines (Data and Clock). To avoid overlap between the drivers of the microphones, one microphone always goes into a high impedance state before the second microphone starts driving the data-line. The edge of this clock is the proper moment for latching the data to the attached application. The LMV1022 is positive edge triggered while the LMV1023 is negative edge triggered. The timing between the two microphones is shown in *Figure 10*. For exact timing values, please see the Electrical Characteristics table.

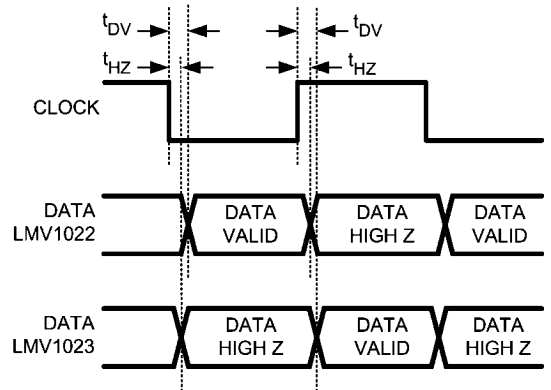

20212429

**FIGURE 10. Timing stereo application**

**LAYOUT CONSIDERATIONS**

To obtain the best possible performance from the microphone, special care needs to be taken for the design of the PCB. The  $V_{IN}$  trace is very sensitive as it is connected to the high impedance electret element. It is essential to isolate and shield the  $V_{IN}$  trace as much as possible from the digital signal traces (DATA and CLOCK). This needs to be done to avoid any switching noise coupling directly into the input of the IC. An example of a PCB layout is given in *Figure 12*. The mi-

crophone PCB has two capacitors. One capacitor (100nF) is connected to the reference pin of the LMV1022/ LMV1023. The other capacitor (100nF) is used as decoupling for high frequencies on the supply. No capacitors should be placed on the data output of the LMV1022/ LMV1023 since it will only load the output driver and would degrade the performance. This is opposite to the regular analog phantom biased microphones, where capacitors are needed to improve RFI.

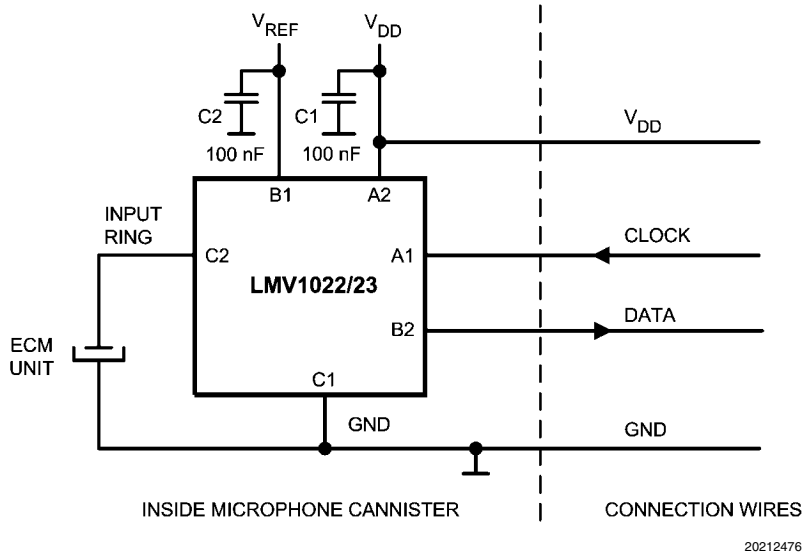

**FIGURE 11. Application schematic for PCB Layout**

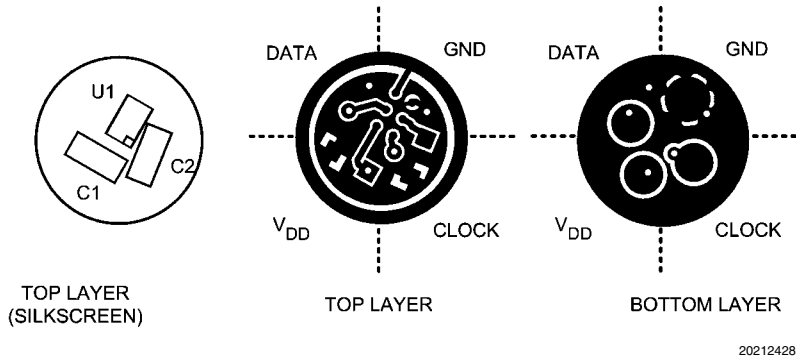

**FIGURE 12. PCB Layout**

**DEMOBOARD**

The LMV1022/LMV1023 demo board provides a means for easy evaluation of digital PDM microphone amplifiers like the LMV1022, LMV1023, LMV1024 and LMV1026. The demo board has the LMV1022 and the LMV1023 in the 6 pin  $\mu$ SMD package mounted ready for evaluation. This demo board also

provides the means by using a DIP socket to evaluate parts on DIP conversion boards and offers a four pin interface to connect other digital PDM sources like microphones containing LMV1022 alike parts. The user guide for this demoboard can be found as application note AN-1784

## Revision History

Rev	Date	Description
1.0	04/04/08	Initial release.

**Physical Dimensions** inches (millimeters) unless otherwise noted

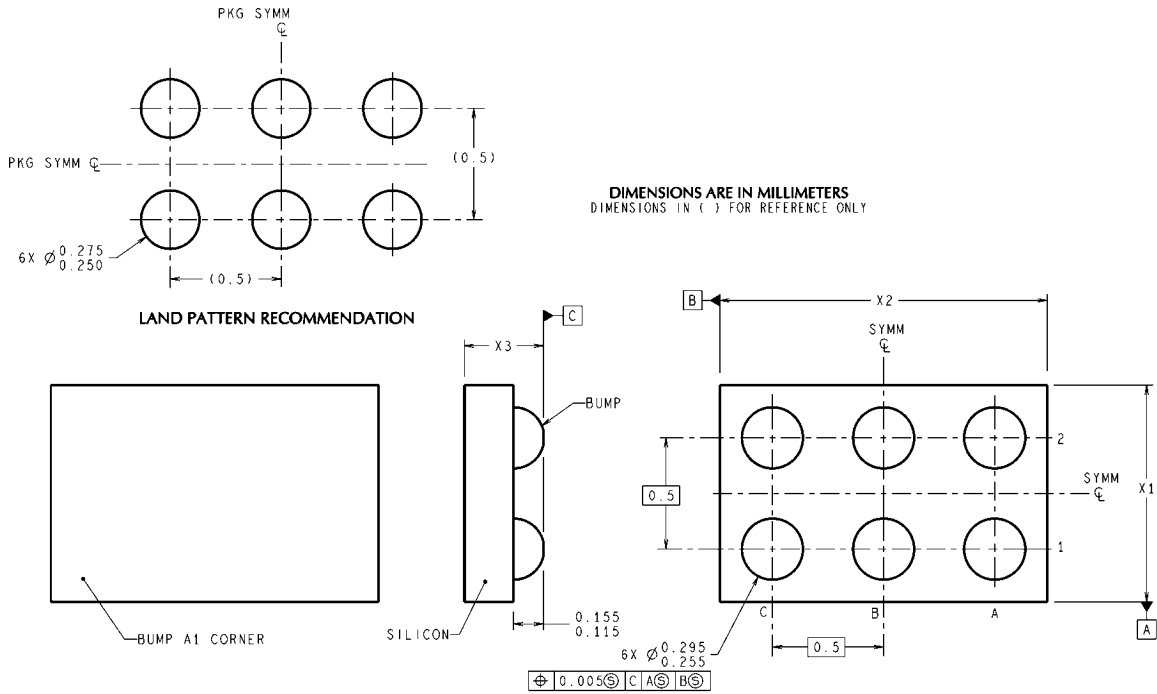

NOTE: UNLESS OTHERWISE SPECIFIED.

1. FOR SOLDER BUMP COMPOSITION, SEE "SOLDER INFORMATION" IN THE PACKAGING SECTION OF THE NATIONAL SEMICONDUCTOR WEB PAGE ([www.national.com](http://www.national.com)).
2. RECOMMEND NON-SOLDER MASK DEFINED LANDING PAD.
3. PIN A1 IS ESTABLISHED BY LOWER LEFT CORNER WITH RESPECT TO TEXT ORIENTATION.
4. XXX IN DRAWING NUMBER REPRESENTS PACKAGE SIZE VARIATION WHERE X1 IS PACKAGE WIDTH, X2 IS PACKAGE LENGTH AND X3 IS PACKAGE HEIGHT.
5. NO JEDEC REGISTRATION AS OF MARCH 2003

**6-Bump Ultra Thin micro SMD**  
**NS Package Number URA06GGA**  
**X<sub>1</sub> = 1.128mm, X<sub>2</sub> = 1.628mm, X<sub>3</sub> = 0.35mm**

## Notes

For more National Semiconductor product information and proven design tools, visit the following Web sites at:

Products		Design Support	
Amplifiers	<a href="http://www.national.com/amplifiers">www.national.com/amplifiers</a>	WEBENCH	<a href="http://www.national.com/webench">www.national.com/webench</a>
Audio	<a href="http://www.national.com/audio">www.national.com/audio</a>	Analog University	<a href="http://www.national.com/AU">www.national.com/AU</a>
Clock Conditioners	<a href="http://www.national.com/timing">www.national.com/timing</a>	App Notes	<a href="http://www.national.com/appnotes">www.national.com/appnotes</a>
Data Converters	<a href="http://www.national.com/adc">www.national.com/adc</a>	Distributors	<a href="http://www.national.com/contacts">www.national.com/contacts</a>
Displays	<a href="http://www.national.com/displays">www.national.com/displays</a>	Green Compliance	<a href="http://www.national.com/quality/green">www.national.com/quality/green</a>
Ethernet	<a href="http://www.national.com/ethernet">www.national.com/ethernet</a>	Packaging	<a href="http://www.national.com/packaging">www.national.com/packaging</a>
Interface	<a href="http://www.national.com/interface">www.national.com/interface</a>	Quality and Reliability	<a href="http://www.national.com/quality">www.national.com/quality</a>
LVDS	<a href="http://www.national.com/lvds">www.national.com/lvds</a>	Reference Designs	<a href="http://www.national.com/refdesigns">www.national.com/refdesigns</a>
Power Management	<a href="http://www.national.com/power">www.national.com/power</a>	Feedback	<a href="http://www.national.com/feedback">www.national.com/feedback</a>
Switching Regulators	<a href="http://www.national.com/switchers">www.national.com/switchers</a>		
LDOs	<a href="http://www.national.com/ldo">www.national.com/ldo</a>		
LED Lighting	<a href="http://www.national.com/led">www.national.com/led</a>		
PowerWise	<a href="http://www.national.com/powerwise">www.national.com/powerwise</a>		
Serial Digital Interface (SDI)	<a href="http://www.national.com/sdi">www.national.com/sdi</a>		
Temperature Sensors	<a href="http://www.national.com/tempsensors">www.national.com/tempsensors</a>		
Wireless (PLL/VCO)	<a href="http://www.national.com/wireless">www.national.com/wireless</a>		

THE CONTENTS OF THIS DOCUMENT ARE PROVIDED IN CONNECTION WITH NATIONAL SEMICONDUCTOR CORPORATION ("NATIONAL") PRODUCTS. NATIONAL MAKES NO REPRESENTATIONS OR WARRANTIES WITH RESPECT TO THE ACCURACY OR COMPLETENESS OF THE CONTENTS OF THIS PUBLICATION AND RESERVES THE RIGHT TO MAKE CHANGES TO SPECIFICATIONS AND PRODUCT DESCRIPTIONS AT ANY TIME WITHOUT NOTICE. NO LICENSE, WHETHER EXPRESS, IMPLIED, ARISING BY ESTOPPEL OR OTHERWISE, TO ANY INTELLECTUAL PROPERTY RIGHTS IS GRANTED BY THIS DOCUMENT.

TESTING AND OTHER QUALITY CONTROLS ARE USED TO THE EXTENT NATIONAL DEEMS NECESSARY TO SUPPORT NATIONAL'S PRODUCT WARRANTY. EXCEPT WHERE MANDATED BY GOVERNMENT REQUIREMENTS, TESTING OF ALL PARAMETERS OF EACH PRODUCT IS NOT NECESSARILY PERFORMED. NATIONAL ASSUMES NO LIABILITY FOR APPLICATIONS ASSISTANCE OR BUYER PRODUCT DESIGN. BUYERS ARE RESPONSIBLE FOR THEIR PRODUCTS AND APPLICATIONS USING NATIONAL COMPONENTS. PRIOR TO USING OR DISTRIBUTING ANY PRODUCTS THAT INCLUDE NATIONAL COMPONENTS, BUYERS SHOULD PROVIDE ADEQUATE DESIGN, TESTING AND OPERATING SAFEGUARDS.

EXCEPT AS PROVIDED IN NATIONAL'S TERMS AND CONDITIONS OF SALE FOR SUCH PRODUCTS, NATIONAL ASSUMES NO LIABILITY WHATSOEVER, AND NATIONAL DISCLAIMS ANY EXPRESS OR IMPLIED WARRANTY RELATING TO THE SALE AND/OR USE OF NATIONAL PRODUCTS INCLUDING LIABILITY OR WARRANTIES RELATING TO FITNESS FOR A PARTICULAR PURPOSE, MERCHANTABILITY, OR INFRINGEMENT OF ANY PATENT, COPYRIGHT OR OTHER INTELLECTUAL PROPERTY RIGHT.

### LIFE SUPPORT POLICY

**NATIONAL'S PRODUCTS ARE NOT AUTHORIZED FOR USE AS CRITICAL COMPONENTS IN LIFE SUPPORT DEVICES OR SYSTEMS WITHOUT THE EXPRESS PRIOR WRITTEN APPROVAL OF THE CHIEF EXECUTIVE OFFICER AND GENERAL COUNSEL OF NATIONAL SEMICONDUCTOR CORPORATION.** As used herein:

Life support devices or systems are devices which (a) are intended for surgical implant into the body, or (b) support or sustain life and whose failure to perform when properly used in accordance with instructions for use provided in the labeling can be reasonably expected to result in a significant injury to the user. A critical component is any component in a life support device or system whose failure to perform can be reasonably expected to cause the failure of the life support device or system or to affect its safety or effectiveness.

National Semiconductor and the National Semiconductor logo are registered trademarks of National Semiconductor Corporation. All other brand or product names may be trademarks or registered trademarks of their respective holders.

Copyright© 2008 National Semiconductor Corporation

For the most current product information visit us at [www.national.com](http://www.national.com)



**National Semiconductor  
Americas Technical  
Support Center**  
Email:  
[new.feedback@nsc.com](mailto:new.feedback@nsc.com)  
Tel: 1-800-272-9959

**National Semiconductor Europe  
Technical Support Center**  
Email: [europe.support@nsc.com](mailto:europe.support@nsc.com)  
German Tel: +49 (0) 180 5010 771  
English Tel: +44 (0) 870 850 4288

**National Semiconductor Asia  
Pacific Technical Support Center**  
Email: [ap.support@nsc.com](mailto:ap.support@nsc.com)

**National Semiconductor Japan  
Technical Support Center**  
Email: [jpn.feedback@nsc.com](mailto:jpn.feedback@nsc.com)