

BUF600
BUF601

HIGH-SPEED BUFFER AMPLIFIER

FEATURES

- OPEN-LOOP BUFFER
- HIGH-SLEW RATE: $3600\text{V}/\mu\text{s}$, 5.0Vp-p
- BANDWIDTH: 320MHz , 5.0Vp-p
 900MHz , 0.2Vp-p
- LOW INPUT BIAS CURRENT: $0.7\mu\text{A}/1.5\mu\text{A}$
- LOW QUIESCENT CURRENT: $3\text{mA}/6\text{mA}$
- GAIN FLATNESS: 0.1dB , 0 to 300MHz

DESCRIPTION

The BUF600 and BUF601 are monolithic open-loop unity-gain buffer amplifiers with a high symmetrical slew rate of up to $3600\text{V}/\mu\text{s}$ and a very wide bandwidth of 320MHz at 5Vp-p output swing. They use a complementary bipolar IC process, which incorporates pn-junction isolated high-frequency NPN and PNP transistors to achieve high-frequency performance previously unattainable with conventional integrated circuit technology.

Their unique design offers a high-performance alternative to expensive discrete or hybrid solutions.

The BUF600 and BUF601 feature low quiescent current, low input bias current, small signal delay time and phase shift, and low differential gain and phase errors.

The BUF600 with 3mA quiescent current is well-suited for operation between high-frequency processing stages. It demonstrates outstanding performance even in feedback loops of wide-band amplifiers or phase-locked loop systems.

APPLICATIONS

- VIDEO BUFFER/LINE DRIVER
- INPUT/OUTPUT AMPLIFIER FOR MEASUREMENT EQUIPMENT
- PORTABLE SYSTEMS
- TRANSMISSION SYSTEMS
- TELECOMMUNICATIONS
- HIGH-SPEED ANALOG SIGNAL PROCESSING
- ULTRASOUND

The BUF601, with 6mA quiescent current and therefore lower output impedance, can easily drive 50Ω inputs or 75Ω systems and cables.

The broad range of analog and digital applications extends from decoupling of signal processing stages, impedance transformation, and input amplifiers for RF equipment and ATE systems to video systems, distribution fields, IF/communications systems, and output drivers for graphic cards.

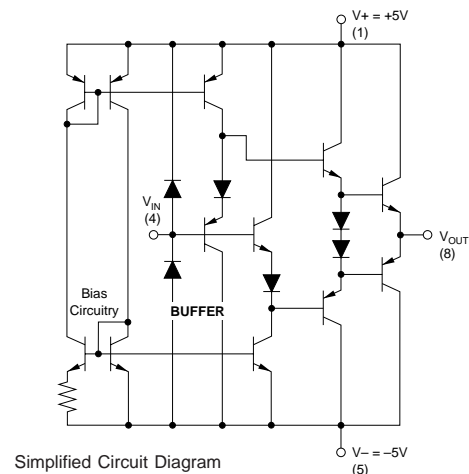

SPECIFICATIONS

DC SPECIFICATION

At $V_{CC} = \pm 5V$, $R_{LOAD} = 10k\Omega$, $R_{SOURCE} = 50\Omega$, and $T_{AMB} = +25^{\circ}C$, unless otherwise noted.

PARAMETER	CONDITIONS	BUF600AP, AU			BUF601AU			UNITS
		MIN	TYP	MAX	MIN	TYP	MAX	
INPUT OFFSET VOLTAGE Initial vs Temperature vs Supply (tracking) vs Supply (non-tracking) vs Supply (non-tracking)	$V_{CC} = \pm 4.5V$ to $\pm 5.5V$ $V_{CC} = +4.5V$ to $+5.5V$ $V_{CC} = -4.5V$ to $-5.5V$		± 15 9	± 30		± 15 25	± 30	mV $\mu V/^{\circ}C$
		-54	-72		-54	-77		dB
			-55			-55		dB
			-54			-54		dB
INPUT BIAS CURRENT Initial vs Temperature vs Supply (tracking) vs Supply (non-tracking) vs Supply (non-tracking)	$V_{CC} = \pm 4.5V$ to $\pm 5.5V$ $V_{CC} = +4.5V$ to $+5.5V$ $V_{CC} = -4.5V$ to $-5.5V$		+3.5 0.4	-2.5/+5		+3.5 0.7	-5/+10	μA $nA/^{\circ}C$
			0.15			0.3		$\mu A/V$
			0.5			0.5		$\mu A/V$
			20			20		nA/V
INPUT IMPEDANCE			4.8 1			2.5 1		M Ω pF
INPUT NOISE Voltage Noise Density Signal-to-Noise Ratio	f = 100kHz to 100MHz S/N = 20 Log (0.7/(Vn • $\sqrt{5MHz}$))		5.2			4.8		nV/\sqrt{Hz}
			95			96		dB
TRANSFER CHARACTERISTICS	Voltage Gain; $V_{IN} = \pm 2.5V$ $R_{LOAD} = 100\Omega$ $R_{LOAD} = 200\Omega$ $R_{LOAD} = 10k\Omega$					0.95		V/V
			0.96					V/V
			0.99				0.99	
RATED OUTPUT Voltage Output DC Current Output Output Impedance	$V_{IN} = \pm 2.7V$ $R_{LOAD} = 100\Omega$ $R_{LOAD} = 200\Omega$ DC, $R_{LOAD} = 100\Omega$				± 2.5	± 2.6		V V
		± 2.5	± 2.6					mA
			6.2			3.6		Ω
POWER SUPPLY Rated Voltage Derated Performance Quiescent Current			± 5			± 5		V V
		± 4.5		± 5.5	± 4.5		± 5.5	mA
		± 2.6	± 3	± 3.4	± 5.4	± 6	± 6.6	
TEMPERATURE RANGE Specification Storage		-40		85	-40		85	$^{\circ}C$
		-40		125	-40		125	$^{\circ}C$

AC SPECIFICATION

At $V_{CC} = \pm 5V$, $R_{LOAD} = 200\Omega$ (BUF600) and 100Ω (BUF601), $R_{SOURCE} = 50\Omega$, and $T_{AMB} = +25^{\circ}C$, unless otherwise noted.

PARAMETER	CONDITIONS	BUF600AP, AU			BUF601AU			UNITS
		MIN	TYP	MAX	MIN	TYP	MAX	
FREQUENCY DOMAIN								
LARGE SIGNAL BANDWIDTH (-3dB)	$V_O = 5Vp-p$, $C_{OUT} = 1pF$ $V_O = 2.8Vp-p$, $C_{OUT} = 1pF$ $V_O = 1.4Vp-p$, $C_{OUT} = 1pF$		320			320		MHz
			400			400		MHz
			700			700		MHz
SMALL SIGNAL BANDWIDTH	$V_O = 0.2Vp-p$, $C_{OUT} = 1pF$		650			900		MHz
GROUP DELAY TIME			250			200		ps
DIFFERENTIAL GAIN	$V_{IN} = 0.3Vp-p$, $f = 4.43MHz$ $V = 0$ to $0.7V$ BUF600 $R_{LOAD} = 200\Omega$ $R_{LOAD} = 1k\Omega$ BUF601 $R_{LOAD} = 100\Omega$ $R_{LOAD} = 500\Omega$		0.5 0.075					% %
						0.4		%
						0.05		%
DIFFERENTIAL PHASE	$V_{IN} = 0.3Vp-p$, $f = 4.43MHz$ $V = 0$ to $0.7V$ BUF600 $R_{LOAD} = 200\Omega$ $R_{LOAD} = 1k\Omega$ BUF601 $R_{LOAD} = 100\Omega$ $R_{LOAD} = 500\Omega$		0.02 0.04					Degrees Degrees
						0.025		Degrees
						0.03		Degrees

AC-SPECIFICATIONS (CONT)

At $V_{CC} = \pm 5V$, $R_{LOAD} = 200\Omega$ (BUF600) and 100Ω (BUF601), $R_{SOURCE} = 50\Omega$, and $T_{AMB} = +25^\circ C$, unless otherwise noted.

PARAMETER	CONDITIONS	BUF600AP, AU			BUF601AU			UNITS
		MIN	TYP	MAX	MIN	TYP	MAX	
HARMONIC DISTORTION Second Harmonic Third Harmonic Second Harmonic Third Harmonic Second Harmonic Third Harmonic	$f = 10MHz$, $V_O = 1.4Vp-p$		-65			-65		dBc
			-64			-67		dBc
	$f = 30MHz$, $V_O = 1.4Vp-p$		-51			-59		dBc
			-56			-62		dBc
	$f = 50MHz$, $V_O = 1.4Vp-p$		-43			-53		dBc
			-48			-54		dBc
GAIN FLATNESS PEAKING	$V_O = 0.4Vp-p$, DC to 30MHz $V_O = 0.4Vp-p$, 30MHz to 300MHz		0.01			0.005		dB
			0.3			0.1		dB
LINEAR PHASE DEVIATION	$V_O = 0.4Vp-p$, DC to 30MHz $V_O = 0.4Vp-p$, 30 to 300MHz		5.5			3.8		Degrees
			55			45		Degrees
TIME DOMAIN								
RISE TIME	10% to 90%, 700ps 1.4Vp-p Step 2.8Vp-p Step 5.0Vp-p Step		0.82			0.87		ns
			0.97			0.95		ns
			1.18			1.13		ns
SLEW RATE	$V_O = 1.4Vp-p$ $V_O = 2.8Vp-p$ $V_O = 5.0Vp-p$		1500			1500		V/ μs
			2400			2400		V/ μs
			3400			3600		V/ μs

PIN CONFIGURATION

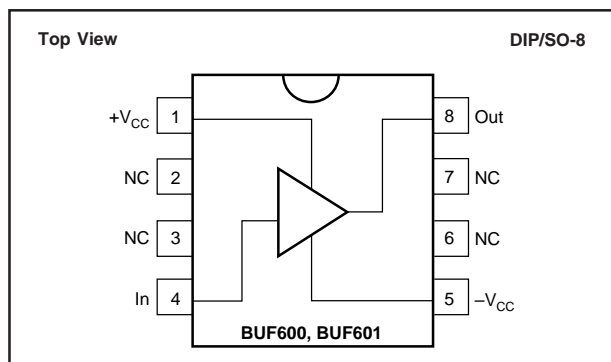

FUNCTIONAL DESCRIPTION

FUNCTION	DESCRIPTION
In	Analog Input
Out	Analog Output
+V _{CC}	Positive Supply Voltage; typical +5VDC
-V _{CC}	Negative Supply Voltage; typical -5VDC

ELECTROSTATIC DISCHARGE SENSITIVITY

This integrated circuit can be damaged by ESD. Burr-Brown recommends that all integrated circuits be handled with appropriate precautions. Failure to observe proper handling and installation procedures can cause damage.

ESD damage can range from subtle performance degradation to complete device failure. Precision integrated circuits may be more susceptible to damage because very small parametric changes could cause the device not to meet its published specifications.

ABSOLUTE MAXIMUM RATINGS

Power Supply Voltage	$\pm 6V$
Input Voltage ⁽¹⁾	$\pm V_{CC} \pm 0.7V$
Operating Temperature	$-40^\circ C$ to $+85^\circ C$
Storage Temperature	$-40^\circ C$ to $+125^\circ C$
Junction Temperature	$+150^\circ C$
Lead Temperature (soldering, 10s)	$+300^\circ C$

NOTE: (1) Inputs are internally diode-clamped to $\pm V_{CC}$.

PACKAGE/ORDERING INFORMATION

PRODUCT	PACKAGE	PACKAGE DRAWING NUMBER ⁽¹⁾	TEMPERATURE RANGE
BUF600AP	Plastic 8-Pin DIP	006	$-40^\circ C$ to $+85^\circ C$
BUF600AU	SO-8 Surface Mount	182	$-40^\circ C$ to $+85^\circ C$
BUF601AU	SO-8 Surface Mount	182	$-40^\circ C$ to $+85^\circ C$

NOTE: (1) For detailed drawing and dimension table, please see end of data sheet, or Appendix C of Burr-Brown IC Data Book.

The information provided herein is believed to be reliable; however, BURR-BROWN assumes no responsibility for inaccuracies or omissions. BURR-BROWN assumes no responsibility for the use of this information, and all use of such information shall be entirely at the user's own risk. Prices and specifications are subject to change without notice. No patent rights or licenses to any of the circuits described herein are implied or granted to any third party. BURR-BROWN does not authorize or warrant any BURR-BROWN product for use in life support devices and/or systems.

INPUT PROTECTION

Static damage has been well recognized for MOSFET devices, but any semiconductor device deserves protection from this potentially damaging source. The BUF600 and BUF601 incorporate on-chip ESD protection diodes as shown in Figure 1. This eliminates the need for the user to add external protection diodes, which can add capacitance and degrade AC performance.

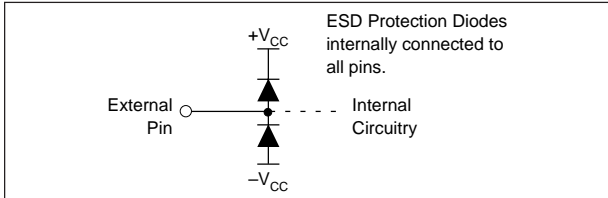

FIGURE 1. Internal ESD Protection.

All input pins on the BUF600 and BUF601 are internally protected from ESD by means of a pair of back-to-back reverse-biased diodes to the power supplies as shown. These diodes will begin to conduct when the input voltage exceeds either power supply by about 0.7V. This situation can occur with loss of the amplifier's power supplies while a signal source is still present. The diodes can typically withstand a continuous current of 30mA without destruction. To insure long term reliability, however, the diode current should be externally limited to 10mA or so whenever possible.

The internal protection diodes are designed to withstand 2.5kV (using the Human Body Model) and will provide adequate ESD protection for most normal handling procedures. However, static damage can cause subtle changes in amplifier input characteristics without necessarily destroying the device. In precision amplifiers, this may cause a noticeable degradation of offset and drift. Therefore, static protection is strongly recommended when handling the BUF600 and BUF601.

TYPICAL PERFORMANCE CURVES

At $V_{CC} = \pm 5V$, $R_{LOAD} = 10k\Omega$, and $T_A = 25^\circ C$, unless otherwise noted.

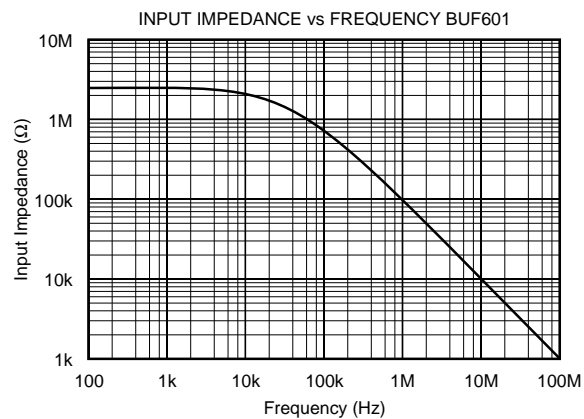
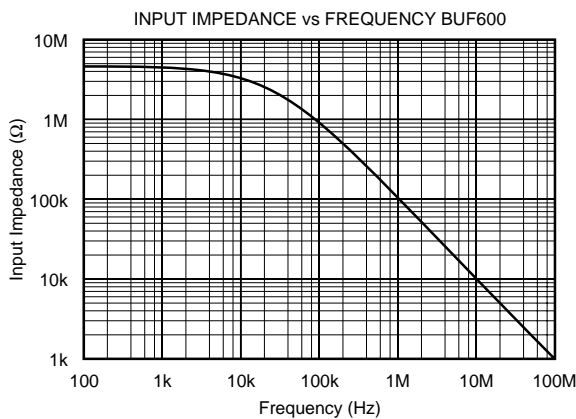
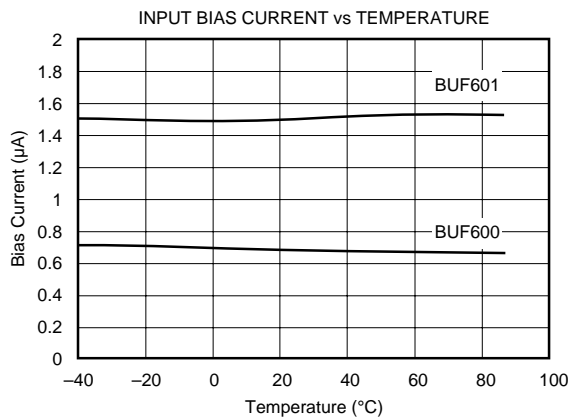
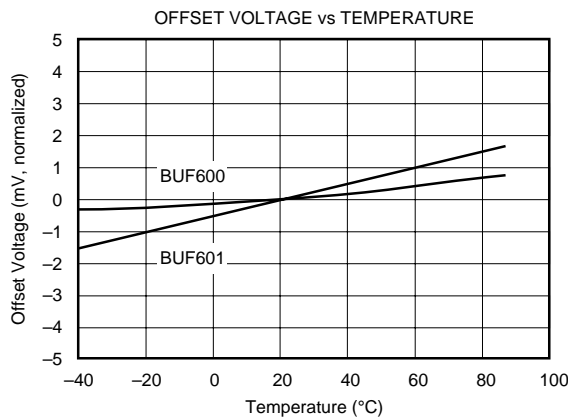

TYPICAL PERFORMANCE CURVES (CONT)

At $V_{CC} = \pm 5V$, $R_{LOAD} = 10k\Omega$, and $T_A = 25^\circ C$, unless otherwise noted.

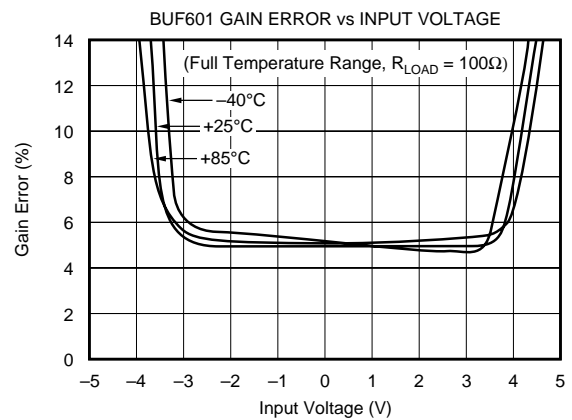
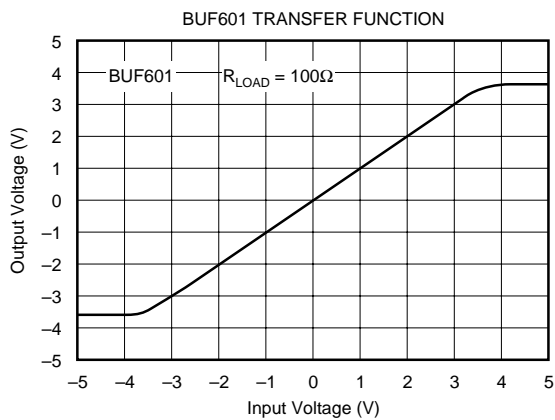
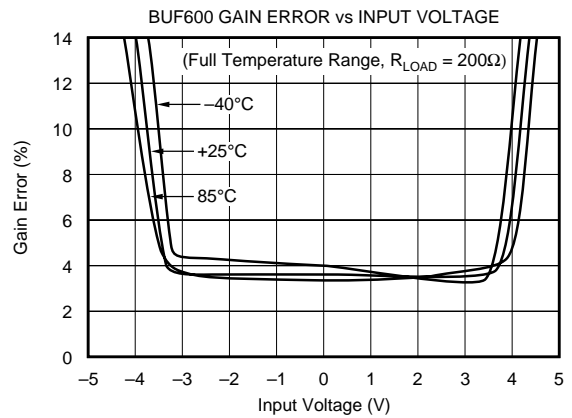
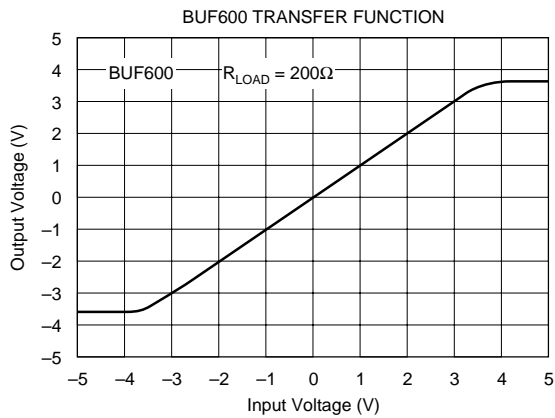
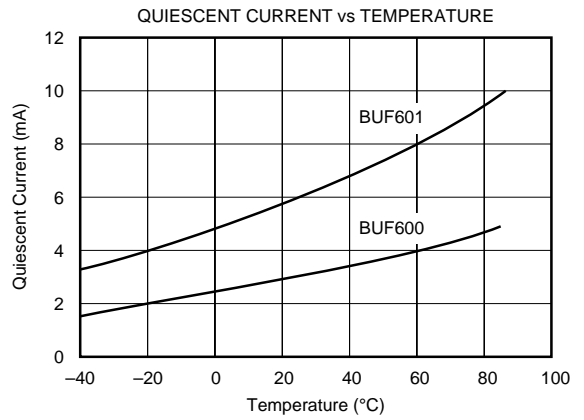
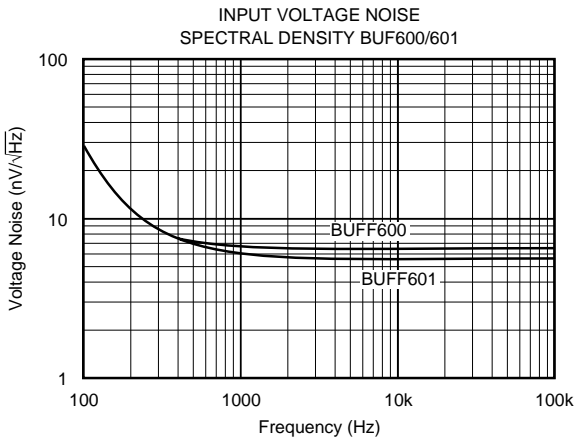

TYPICAL PERFORMANCE CURVES (CONT)

At $V_{CC} = \pm 5V$, $R_{LOAD} = 100\Omega$ (BUF601), $R_{LOAD} = 200\Omega$ (BUF600), and $T_A = 25^\circ C$, unless otherwise noted.

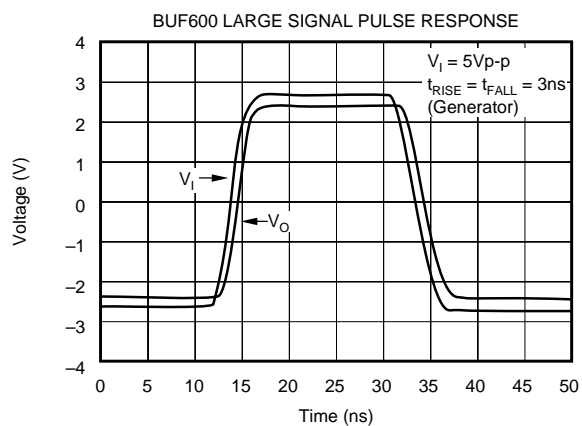
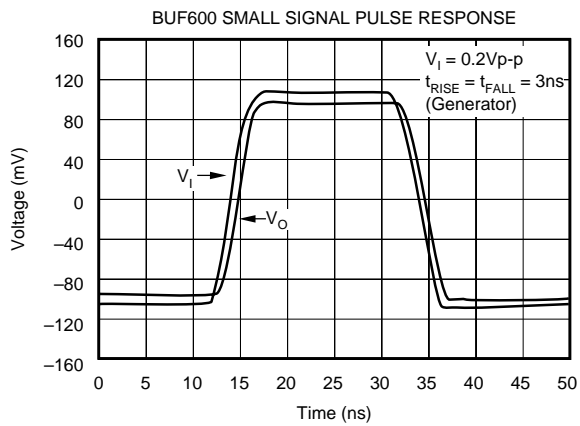
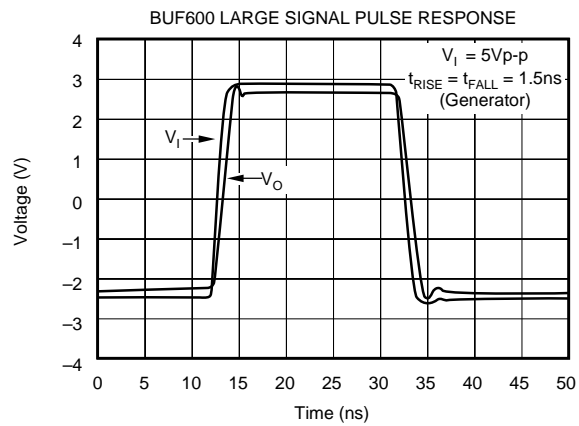
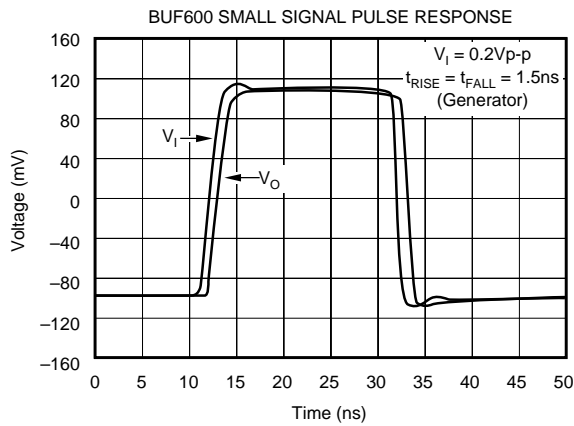
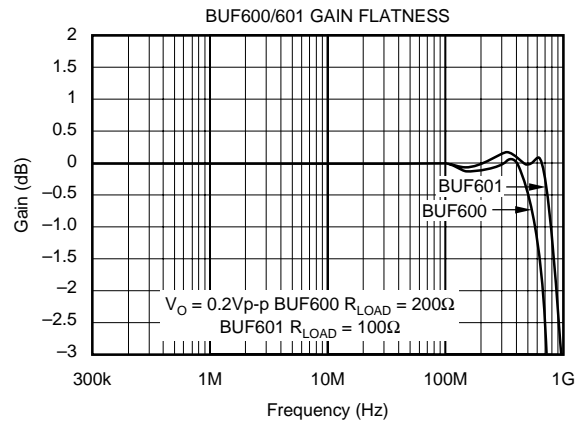
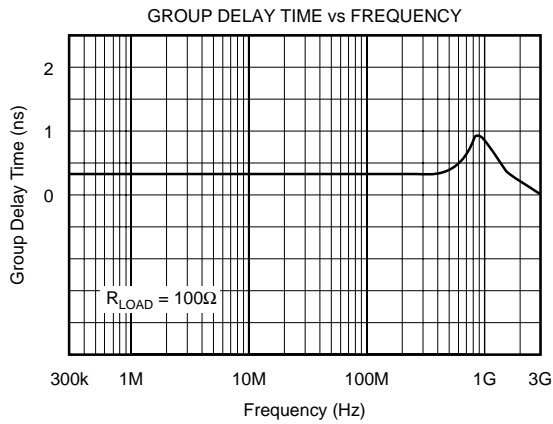

TYPICAL PERFORMANCE CURVES (CONT)

At $V_{CC} = \pm 5V$, $R_{LOAD} = 100\Omega$ (BUF601), $R_{LOAD} = 200\Omega$ (BUF600), and $T_A = 25^\circ C$, unless otherwise noted.

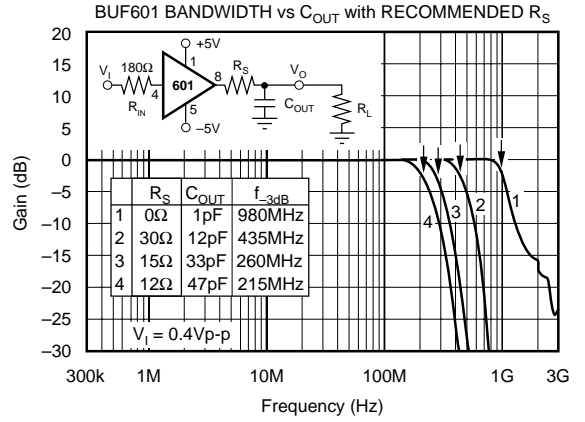
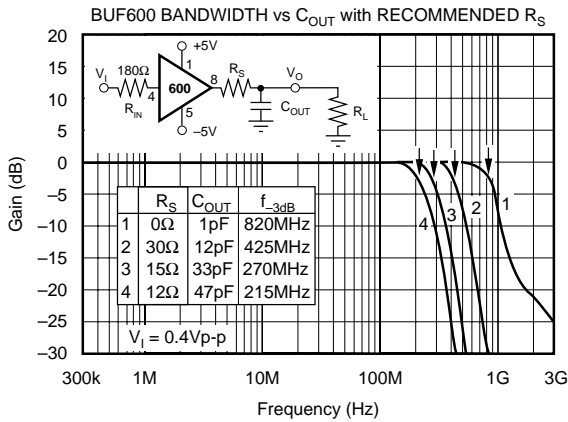
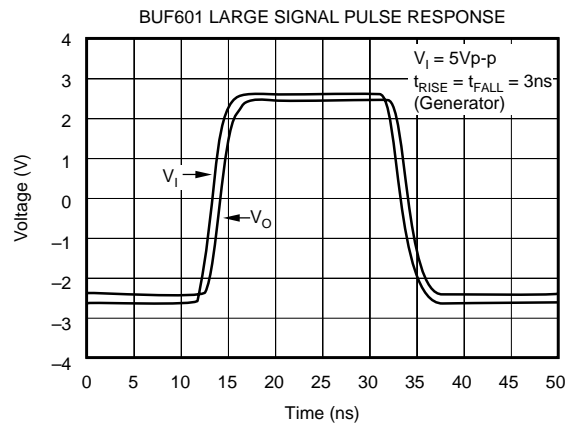
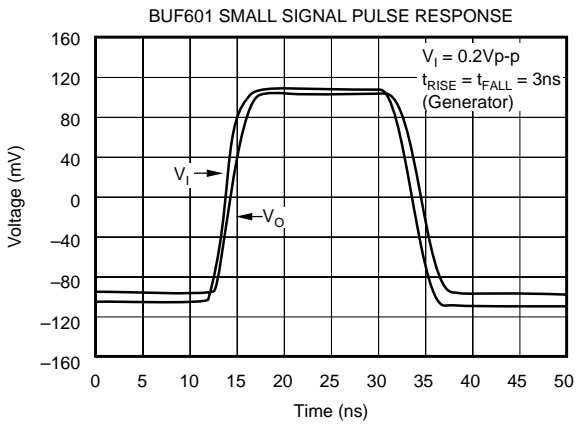
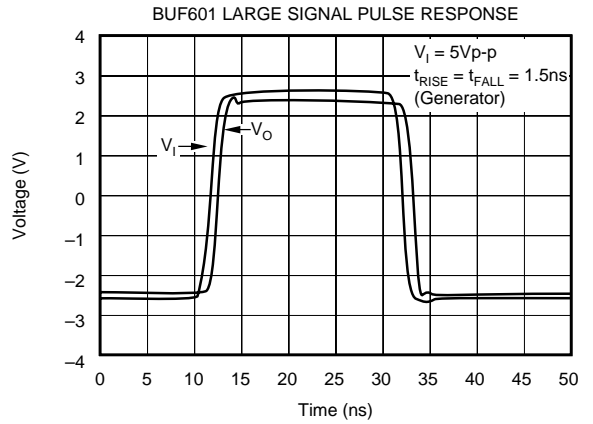
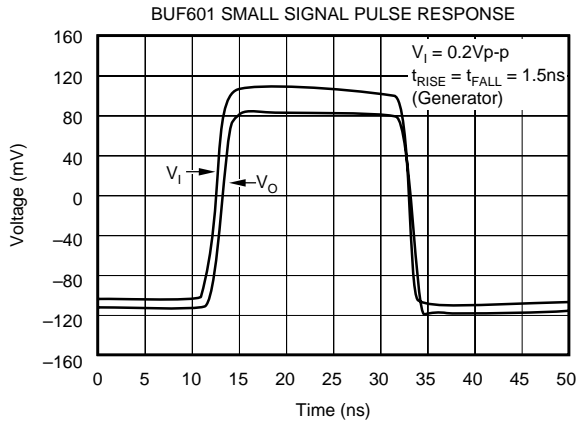

TYPICAL PERFORMANCE CURVES (CONT)

At $V_{CC} = \pm 5V$, $R_{LOAD} = 100\Omega$ (BUF601), $R_{LOAD} = 200\Omega$ (BUF600), and $T_A = 25^\circ C$, unless otherwise noted.

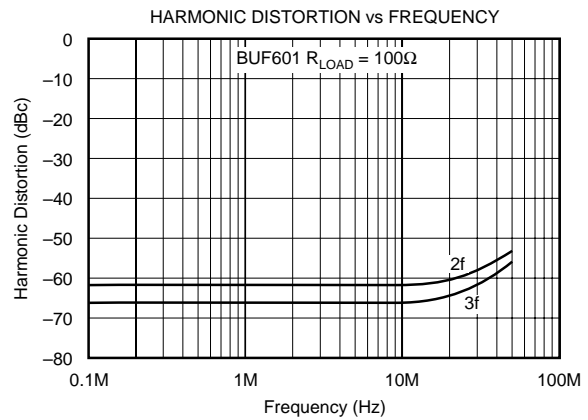
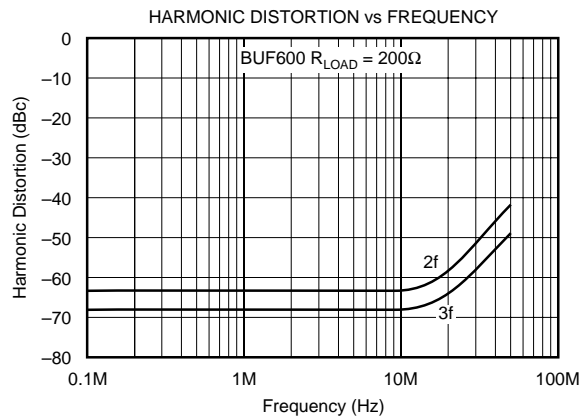
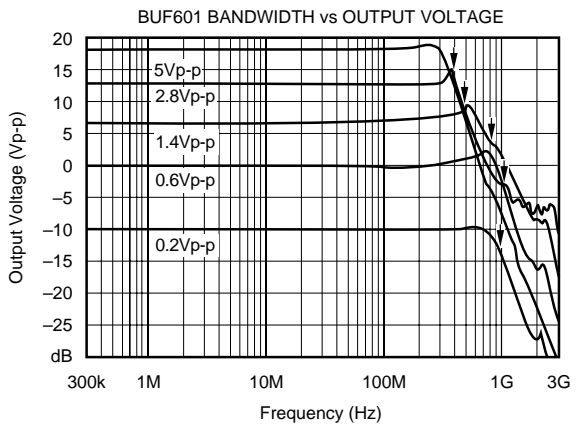
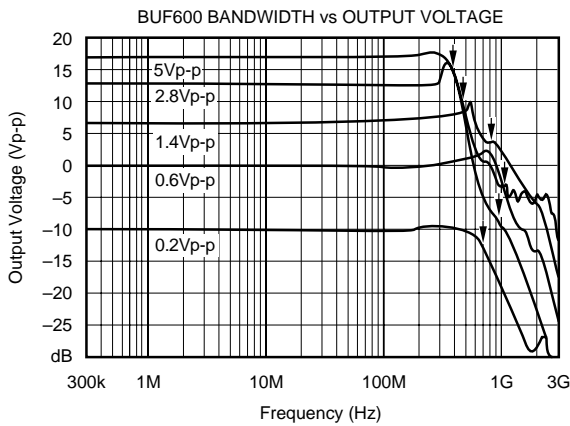
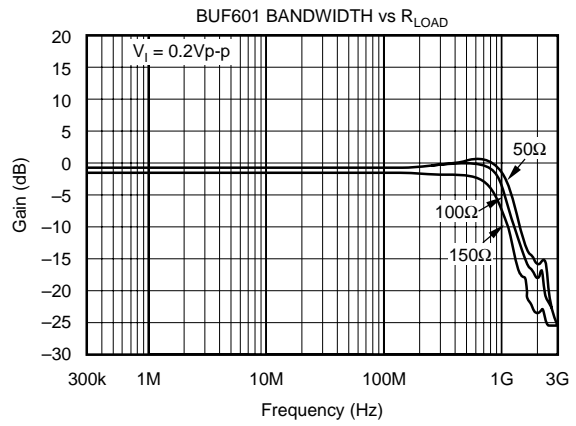
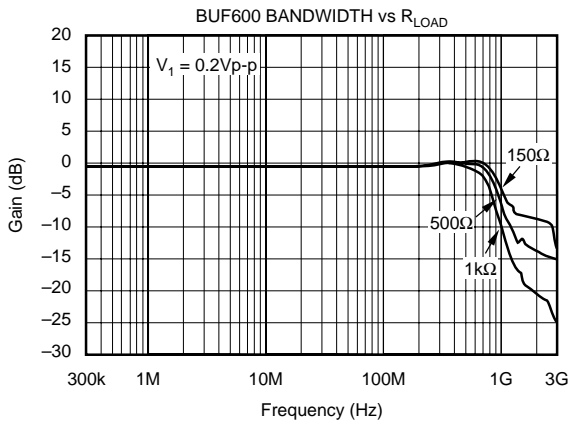

TYPICAL PERFORMANCE CURVES (CONT)

At $V_{CC} = \pm 5V$, $R_{LOAD} = 100\Omega$ (BUF601), $R_{LOAD} = 200\Omega$ (BUF600), and $T_A = 25^\circ C$, unless otherwise noted.

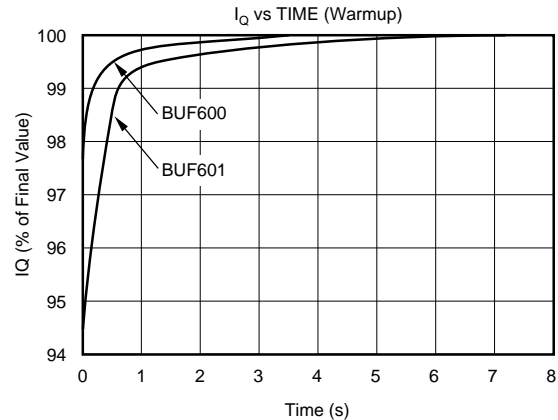
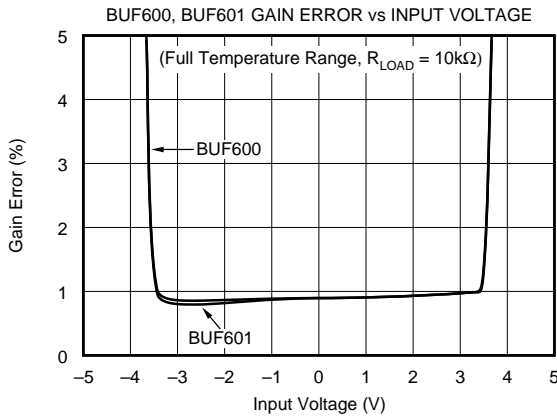

DISCUSSION OF PERFORMANCE

The BUF600 and BUF601 are fabricated using a high-performance complementary bipolar process, which provides high-frequency NPN and PNP transistors with gigahertz transition frequencies (f_T). Power supplies are rated at $\pm 6V$ maximum, with the data sheet parameters specified at $\pm 5V$ supplies. The BUF600 and BUF601 are 3-stage open-loop buffer amplifiers consisting of complementary emitter followers with a symmetrical class AB Darlington output stage. The complementary structure provides both sink and source current capability independent of the output voltage, while maintaining constant output and input impedances. The amplifiers use no feedback, so their low-frequency gain is slightly less than unity and somewhat dependent on loading. The optimized input stage is responsible for the high slew rate of up to $3600V/\mu s$, wide large signal bandwidth of 320MHz, and quiescent current reduction to $\pm 3mA$ (BUF600) and $\pm 6mA$ (BUF601). These features yield an excellent large signal bandwidth/quiescent current ratio of 320MHz, 5Vp-p at 3mA/6mA quiescent current. The complementary emitter followers of the input stage work with current sources as loads. The internal PTAT power supply controls their quiescent current and with its temperature characteristics keeps the transconductance of the buffer amplifiers constant. The Typical Performance Curves show the quiescent current variation versus temperature.

The cross current in the input stage is kept very low, resulting in a low input bias current of $0.7\mu A/1.5\mu A$ and high input impedance of $4.8M\Omega \parallel 1pF/2.5M\Omega \parallel 1pF$. The second stage drives the output transistors and reduces the output impedance and the feedthrough from output to input when driving RLC loads.

The input of the BUF600 and BUF601 looks like a high resistance in parallel with a 1pF capacitance. The input characteristics change very little with output loading and input voltage swing. The BUF600 and BUF601 have excellent input-to-output isolation and feature high tolerance to

variations in source impedances. A resistor between 100Ω and 250Ω in series with the buffer input lead will usually eliminate oscillation problems from inductive sources such as unterminated cables without sacrificing speed.

Another excellent feature is the output-to-input isolation over a wide frequency range. This characteristic is very important when the buffer drives different equipment over cables. Often the cable is not perfect or the termination is incorrect and reflections arise that act like a signal source at the output of the buffer.

Open-loop devices often sacrifice linearity and introduce frequency distortion when driving low load impedance. The BUF600 and BUF601, however, do not. Their design yields low distortion products. The harmonic distortion characteristics into loads greater than 100Ω (BUF601) and greater than 200Ω (BUF600) are shown in the Typical Performance Curves. The distortion can be improved even more by increasing the load resistance.

Differential gain (DG) and differential phase (DP) are among the important specifications for video applications. DG is defined as the percent change in gain over a specified change in output voltage level (0V to 0.7V.) DP is defined as the phase change in degrees over the same output voltage change. Both DG and DP are specified at the PAL subcarrier frequency of 4.43MHz. The errors for differential gain are lower than 0.5%, while those for differential phase are lower than 0.04° .

With its minimum 20mA long-term DC output current capability, 50mA pulse current, low output impedance over frequency, and stability to drive capacitive loads, the BUF601 can drive 50Ω and 75Ω systems or lines. The BUF600 with lower quiescent current and therefore higher output impedance is well-suited primarily to interstage buffering. This type of open-loop amplifier is a new and easy-to-use step to prevent an interaction between two points in complex high-speed analog circuitry.

The buffer outputs are not current-limited or protected. If the output is shorted to ground, high currents could arise when the input voltage is $\pm 3.6\text{V}$. Momentary shorts to ground (a few seconds) should be avoided but are unlikely to cause permanent damage.

CIRCUIT LAYOUT

The high-frequency performance of the BUF600 and BUF601 can be greatly affected by the physical layout of the printed circuit board. The following tips are offered as suggestions, not as absolute musts. Oscillations, ringing, poor bandwidth and settling, and peaking are all typical problems that plague high-speed components when they are used incorrectly.

- Bypass power supplies very close to the device pins. Use tantalum chip capacitors (approximately $2.2\mu\text{F}$); a parallel 470nF ceramic chip capacitor may be added if desired. Surface-mount types are recommended due to their low lead inductance.
- PC board traces for power lines should be wide to reduce impedance or inductance.
- Make short and low inductance traces. The entire physical circuit should be as small as possible.
- Use a low-impedance ground plane on the component side to ensure that low-impedance ground is available throughout the layout.
- Do not extend the ground plane under high-impedance nodes sensitive to stray capacitances, such as the buffer's input terminals.
- Sockets are not recommended, because they add significant inductance and parasitic capacitance. If sockets must be used, consider using zero-profile solderless sockets.
- Use low-inductance and surface-mounted components. Using all surface-mount components will offer the best AC performance.
- A resistor (100Ω to 250Ω) in series with the input of the buffers may help to reduce peaking.
- Plug-in prototype boards and wire-wrap boards will not function well. A clean layout using RF techniques is essential—there are no shortcuts.

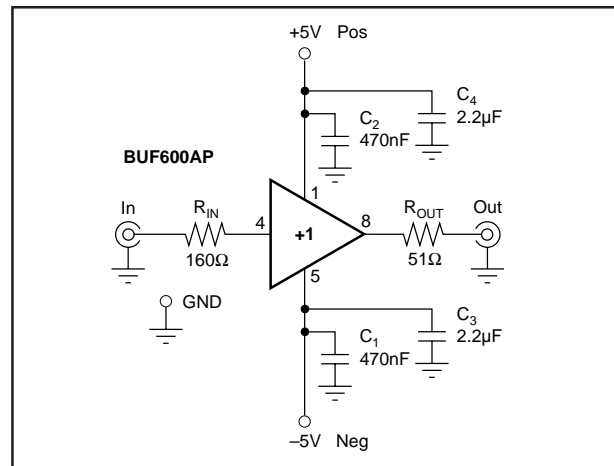

FIGURE 2. Test Circuit.

IMPEDANCE MATCHING

The BUF600 and BUF601 provide power gain and isolation between source and load when used as an active tap or impedance matching device as illustrated in Figure 3. In this example, there is no output matching path between the buffer and the 75Ω line. Such matching is not needed when the distant end of the cable is properly terminated, since there is no reflected signal when the buffer isolates the source. This technique allows the full output voltage of the buffer to be applied to the load.

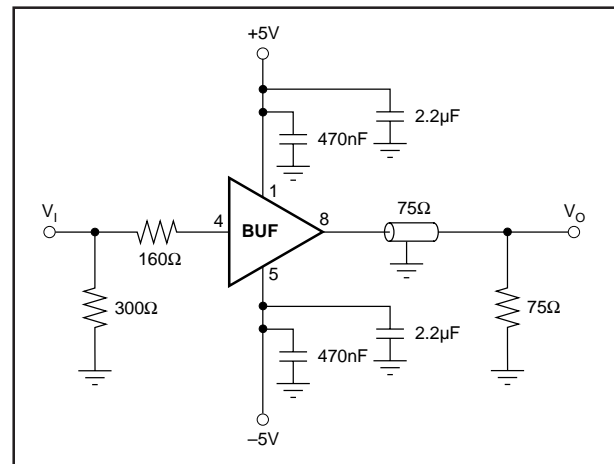

FIGURE 3. Impedance Converter.

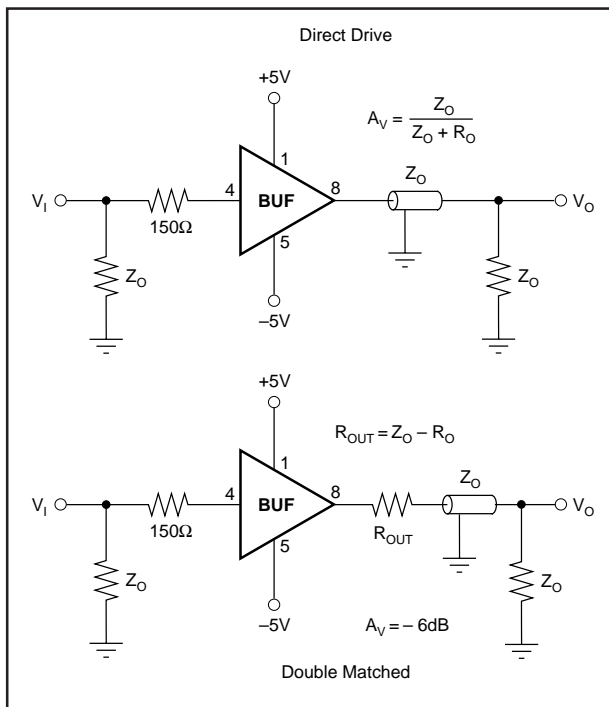

FIGURE 4. Driving Cables.

DRIVING CABLES

The most obvious way is to connect the cable directly to the output of the buffer. This results in a gain determined by the buffer output resistance and the characteristic impedance of the cable, assuming it is properly terminated.

Double termination of a cable is the cleanest way to drive it, since reflections are absorbed on both ends of the cable. The cable source resistor is equal to the characteristic impedance less the output resistance of the buffer amplifiers. The gain is -6dB excluding of the cable attenuation.

VIDEO DISTRIBUTION AMPLIFIER

In this broadcast quality circuit, the OPA623 provides a very high input impedance so that it may be used with a wide variety of signal sources including video DACs, CCD cameras, video switches or 75Ω cables. The OPA623 provides a voltage gain of 2.5V/V , while the potentiometer of 200Ω allows the overall gain to be adjusted to drive the standard signal levels into the back-terminated 75Ω cables. Back matching prevents multiple reflections in the event that the remote end of the cable is not properly terminated.

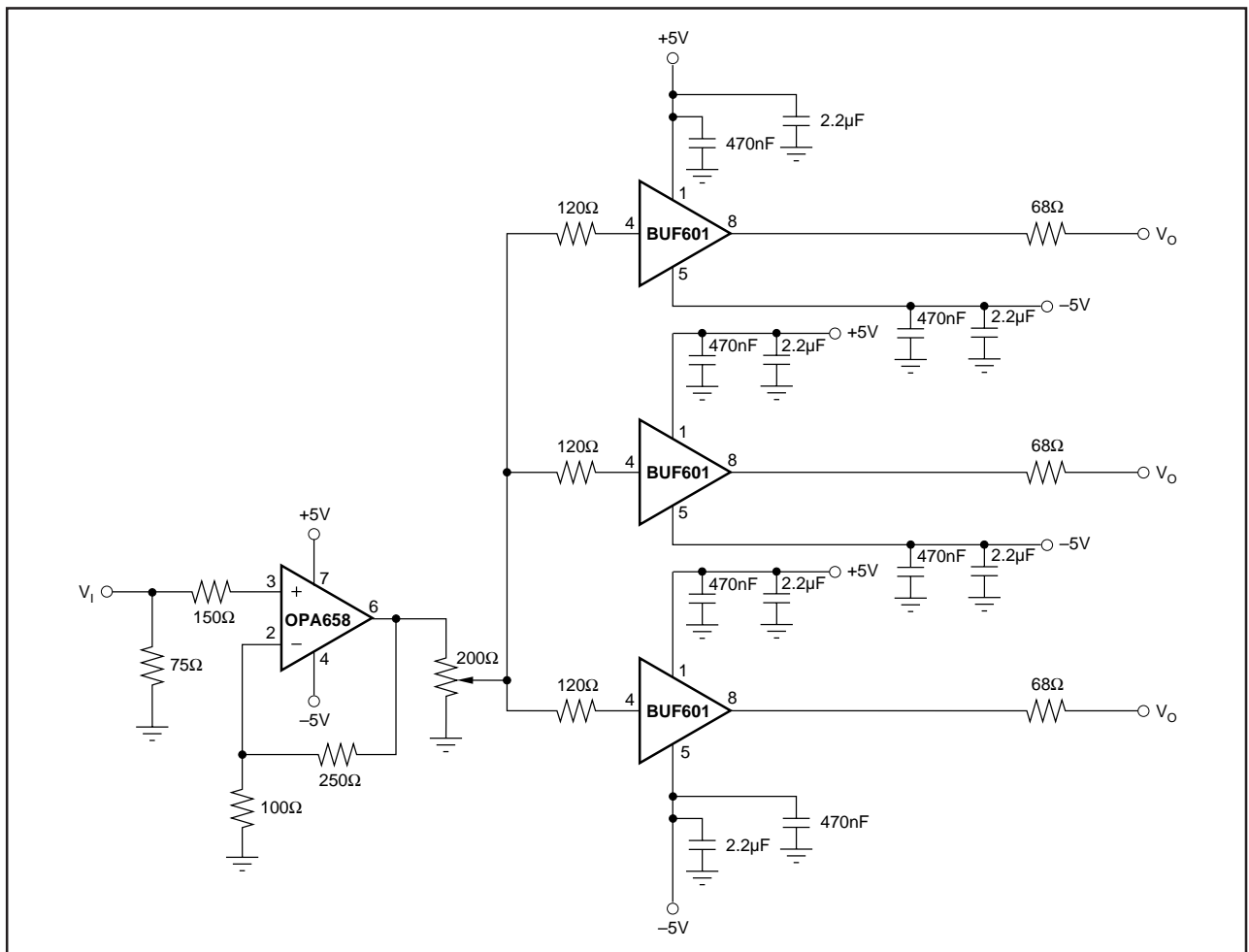

FIGURE 5. Video Distribution Amplifier.

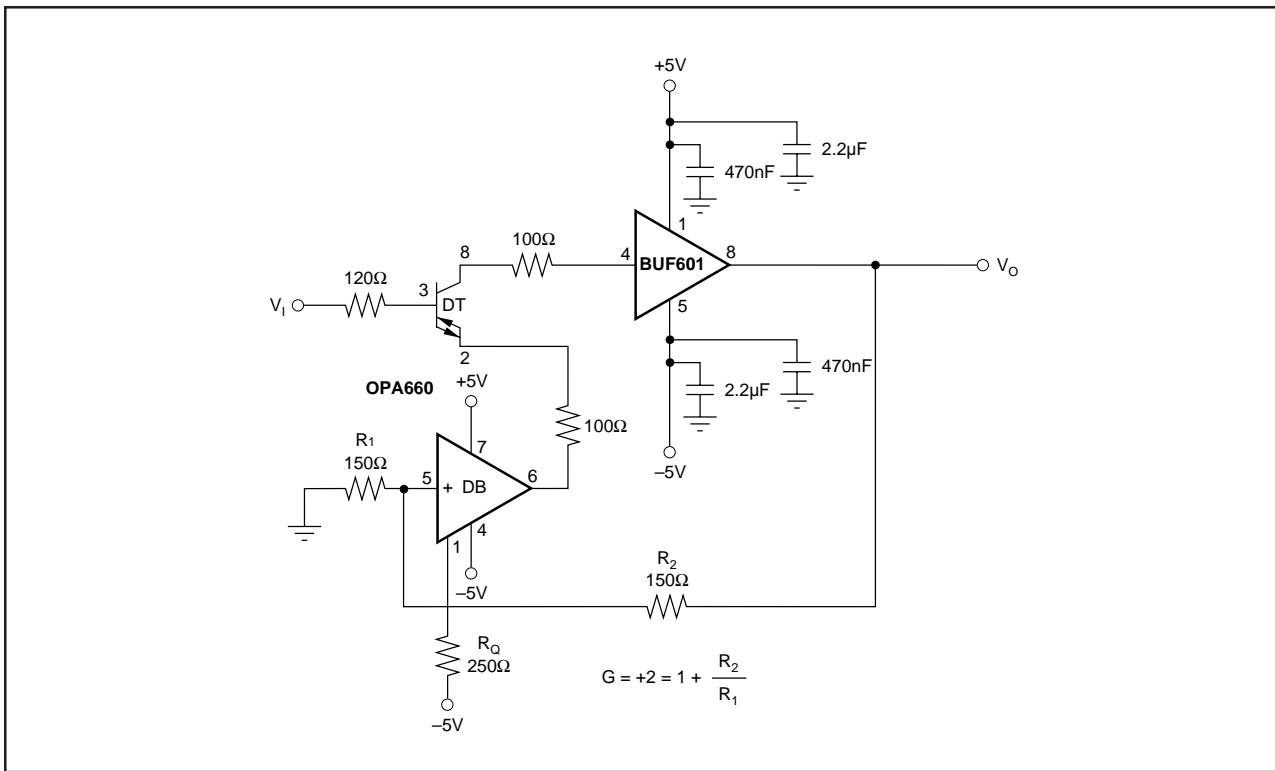

FIGURE 6. Inside a Feedback Loop of a Voltage Feedback Amplifier (BUF601 and OPA660).

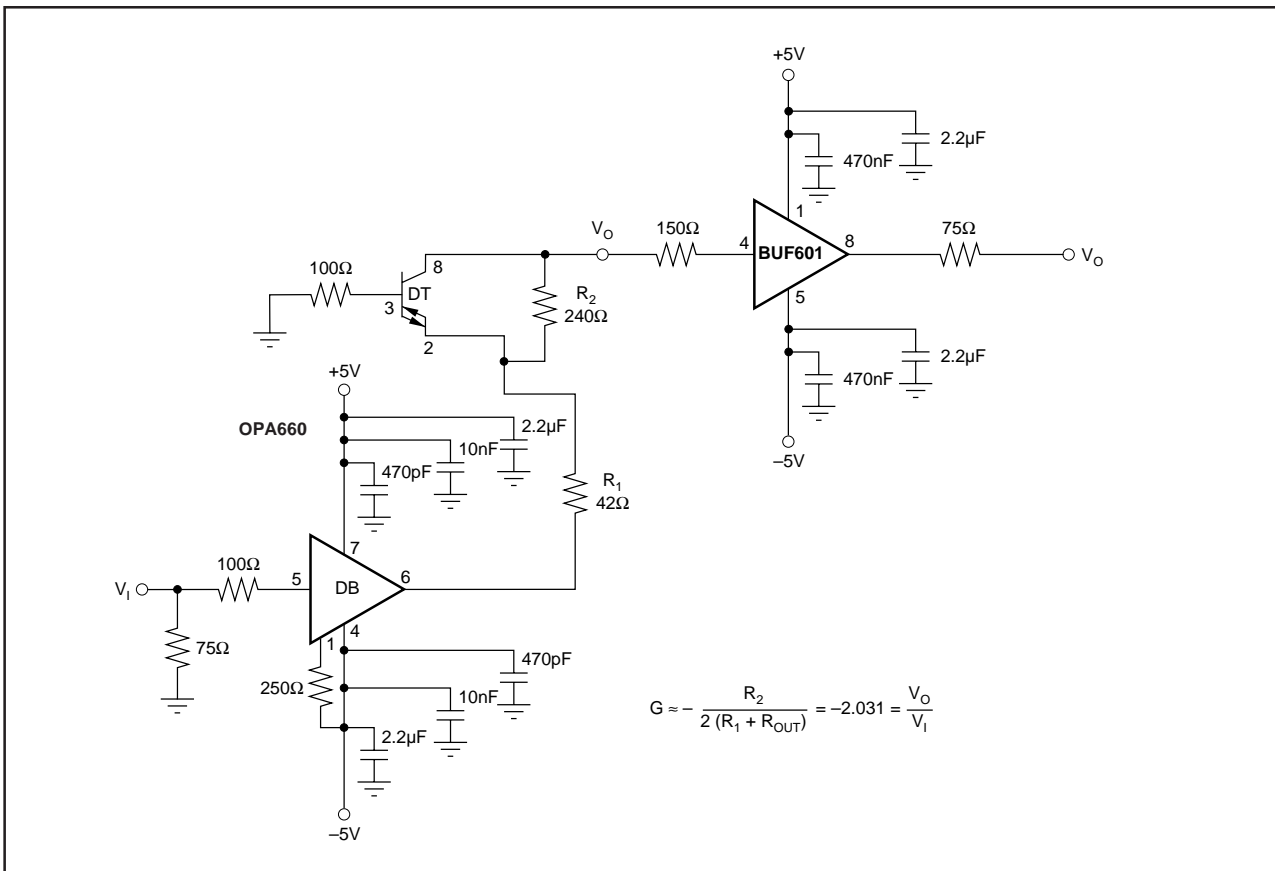

FIGURE 7. Output Buffer for an Inverting RF-Amplifier (Direct Feedback).

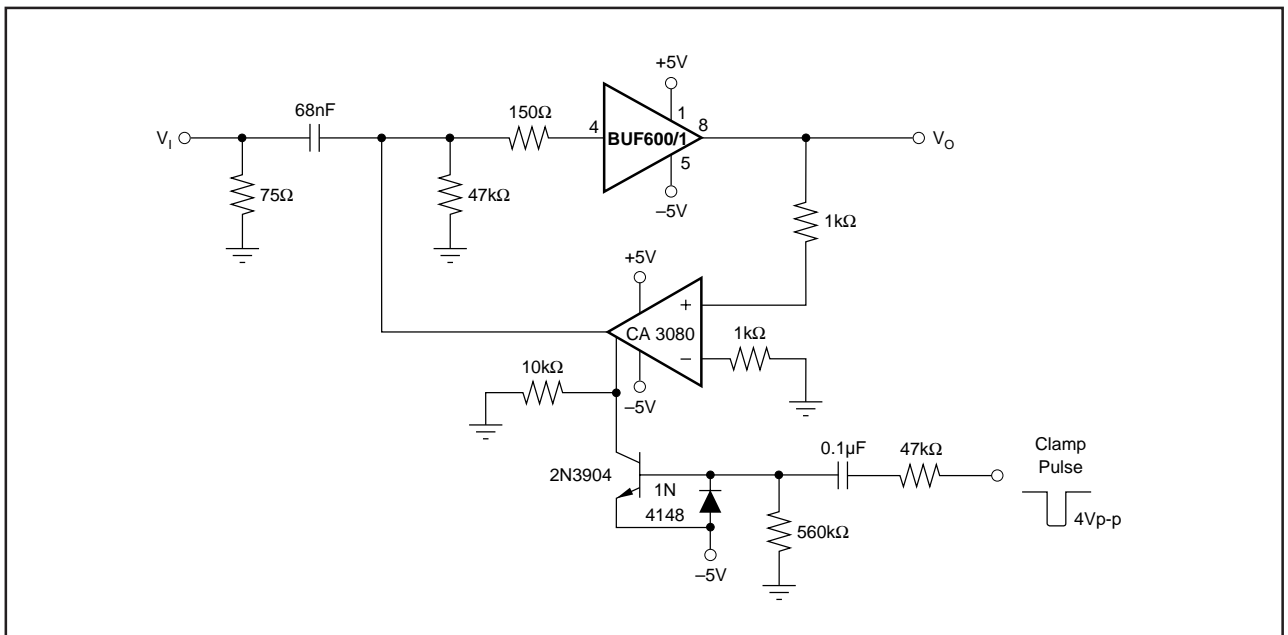

FIGURE 8. Input Amplifier with Baseband Video DC Restoration.

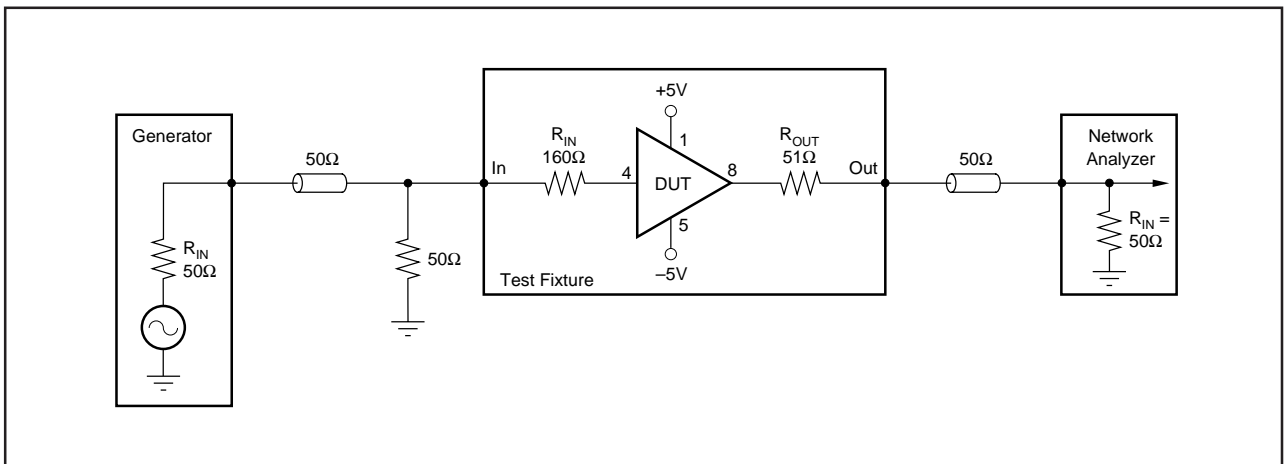

FIGURE 9. Test Circuit Frequency Response.

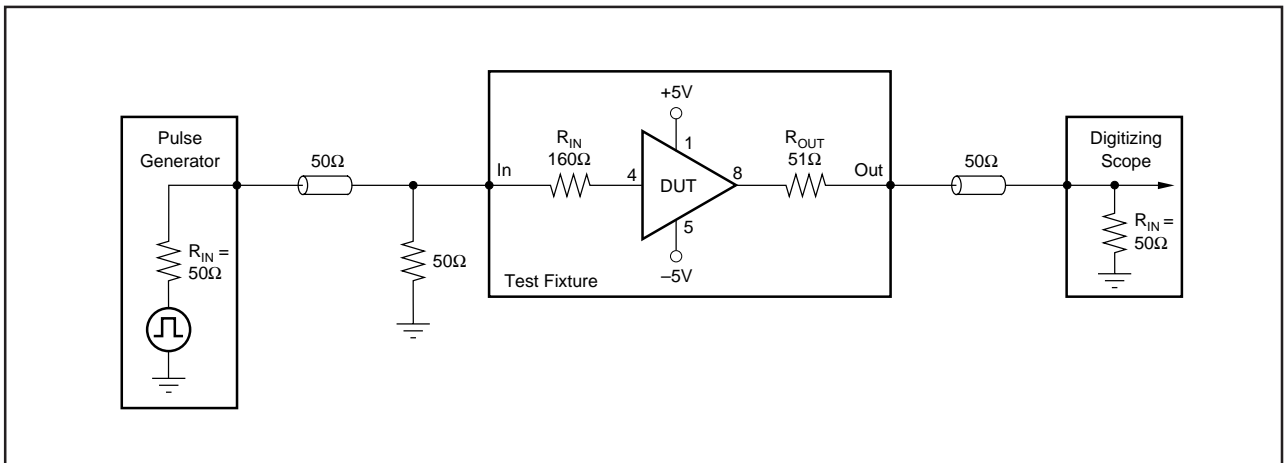

FIGURE 10. Test Circuit Pulse Response.

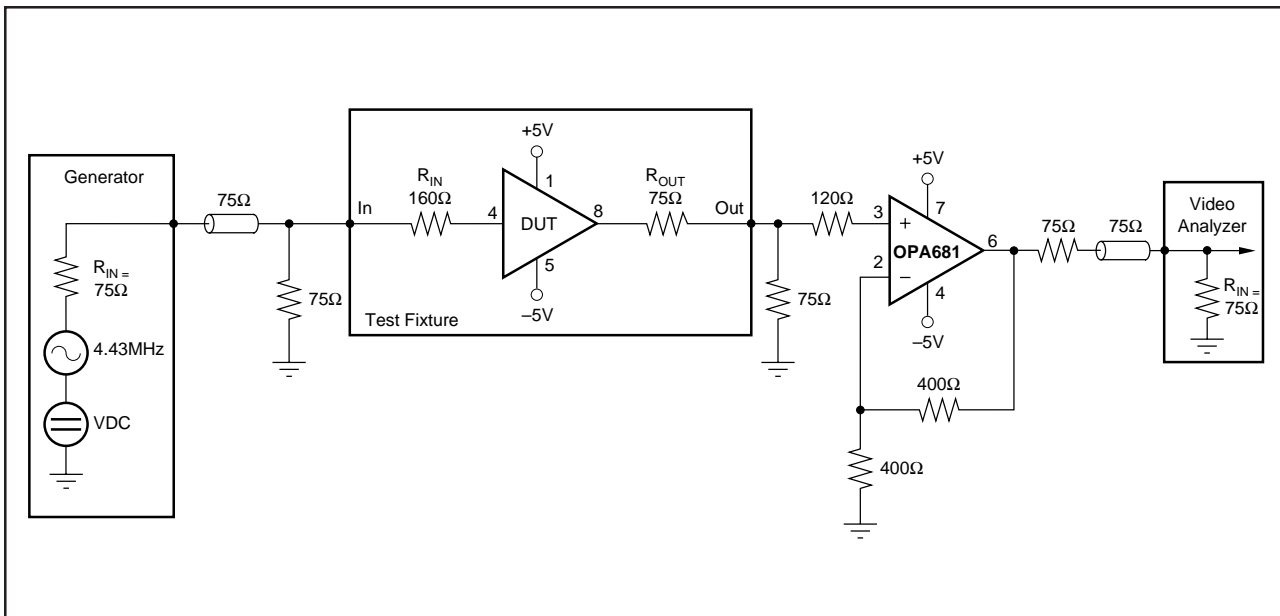

FIGURE 11. Test Circuit Differential Gain and Phase.

This datasheet has been downloaded from:

www.DatasheetCatalog.com

Datasheets for electronic components.



LittleDiode supplies new, hard to find or obsolete electronic components and semiconductors all over the world.

With over two million different components listed you are sure to find the part you need.

Feel free to visit us today at our online store:

LittleDiode.com

Looking forward to providing you with the best possible service.