

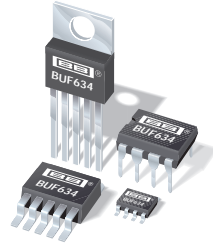

**BUF634**



## 250mA HIGH-SPEED BUFFER

### FEATURES

- HIGH OUTPUT CURRENT: 250mA
- SLEW RATE: 2000V/ $\mu$ s
- PIN-SELECTED BANDWIDTH: 30MHz to 180MHz
- LOW QUIESCENT CURRENT: 1.5mA (30MHz BW)
- WIDE SUPPLY RANGE:  $\pm 2.25$  to  $\pm 18$ V
- INTERNAL CURRENT LIMIT
- THERMAL SHUTDOWN PROTECTION
- 8-PIN DIP, SO-8, 5-LEAD TO-220, 5-LEAD DDPAK SURFACE-MOUNT

### APPLICATIONS

- VALVE DRIVER
- SOLENOID DRIVER
- OP AMP CURRENT BOOSTER
- LINE DRIVER
- HEADPHONE DRIVER
- VIDEO DRIVER
- MOTOR DRIVER
- TEST EQUIPMENT
- ATE PIN DRIVER

### DESCRIPTION

The BUF634 is a high speed unity-gain open-loop buffer recommended for a wide range of applications. It can be used inside the feedback loop of op amps to increase output current, eliminate thermal feedback and improve capacitive load drive.

For low power applications, the BUF634 operates on 1.5mA quiescent current with 250mA output, 2000V/ $\mu$ s slew rate and 30MHz bandwidth. Bandwidth can be adjusted from 30MHz to 180MHz by connecting a resistor between  $V_-$  and the BW Pin.

Output circuitry is fully protected by internal current limit and thermal shut-down making it rugged and easy to use.

The BUF634 is available in a variety of packages to suit mechanical and power dissipation requirements. Types include 8-pin DIP, SO-8 surface-mount, 5-lead TO-220, and a 5-lead DDPAK surface-mount plastic power package.

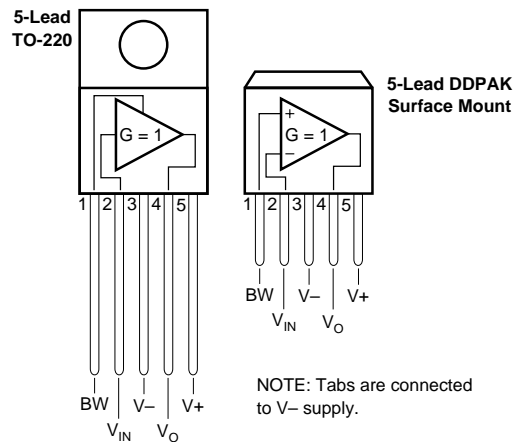
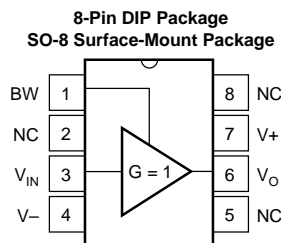

# SPECIFICATIONS

## ELECTRICAL

At  $T_A = +25^\circ\text{C}^{(1)}$ ,  $V_S = \pm 15\text{V}$ , unless otherwise noted.

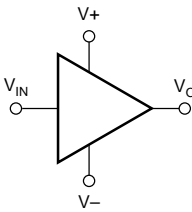
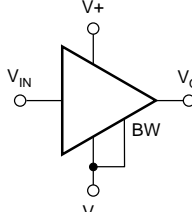
PARAMETER	CONDITION	BUF634P, U, T, F						UNITS
		LOW QUIESCENT CURRENT MODE			WIDE BANDWIDTH MODE			
		MIN	TYP	MAX	MIN	TYP	MAX	
<b>INPUT</b>								
Offset Voltage	Specified Temperature Range $V_S = \pm 2.25\text{V}^{(2)}$ to $\pm 18\text{V}$ $V_{IN} = 0\text{V}$ $R_L = 100\Omega$ $f = 10\text{kHz}$		$\pm 30$	$\pm 100$		*	*	mV
vs Temperature			$\pm 100$			*	*	$\mu\text{V}/^\circ\text{C}$
vs Power Supply			0.1	1		*	*	mV/V
Input Bias Current			$\pm 0.5$	$\pm 2$		$\pm 5$	$\pm 20$	$\mu\text{A}$
Input Impedance			$80 \parallel 8$		$8 \parallel 8$		$\text{M}\Omega \parallel \text{pF}$	
Noise Voltage			4		*		$\text{nV}/\sqrt{\text{Hz}}$	
<b>GAIN</b>								
	$R_L = 1\text{k}\Omega$ , $V_O = \pm 10\text{V}$	0.95	0.99		*	*	V/V	
	$R_L = 100\Omega$ , $V_O = \pm 10\text{V}$	0.85	0.93		*	*	V/V	
	$R_L = 67\Omega$ , $V_O = \pm 10\text{V}$	0.8	0.9		*	*	V/V	
<b>OUTPUT</b>								
Current Output, Continuous			$\pm 250$			*		mA
Voltage Output, Positive	$I_O = 10\text{mA}$	(V+) -2.1	(V+) -1.7		*	*		V
Negative	$I_O = -10\text{mA}$	(V-) +2.1	(V-) +1.8		*	*		V
Positive	$I_O = 100\text{mA}$	(V+) -3	(V+) -2.4		*	*		V
Negative	$I_O = -100\text{mA}$	(V-) +4	(V-) +3.5		*	*		V
Positive	$I_O = 150\text{mA}$	(V+) -4	(V+) -2.8		*	*		V
Negative	$I_O = -150\text{mA}$	(V-) +5	(V-) +4		*	*		V
Short-Circuit Current			$\pm 350$	$\pm 550$		$\pm 400$	*	mA
<b>DYNAMIC RESPONSE</b>								
Bandwidth, -3dB	$R_L = 1\text{k}\Omega$		30			180		MHz
	$R_L = 100\Omega$		20			160		MHz
Slew Rate	$20\text{Vp-p}$ , $R_L = 100\Omega$		2000			*		V/ $\mu\text{s}$
Settling Time, 0.1%	$20\text{V Step}$ , $R_L = 100\Omega$		200			*		ns
1%	$20\text{V Step}$ , $R_L = 100\Omega$		50			*		ns
Differential Gain	$3.58\text{MHz}$ , $V_O = 0.7\text{V}$ , $R_L = 150\Omega$		4			0.4		%
Differential Phase	$3.58\text{MHz}$ , $V_O = 0.7\text{V}$ , $R_L = 150\Omega$		2.5			0.1		$^\circ$
<b>POWER SUPPLY</b>								
Specified Operating Voltage			$\pm 15$			*		V
Operating Voltage Range		$\pm 2.25^{(2)}$		$\pm 18$	*		*	V
Quiescent Current, $I_Q$	$I_O = 0$		$\pm 1.5$	$\pm 2$		$\pm 15$	$\pm 20$	mA
<b>TEMPERATURE RANGE</b>								
Specification		-40		+85	*		*	$^\circ\text{C}$
Operating		-40		+125	*		*	$^\circ\text{C}$
Storage		-55		+125	*		*	$^\circ\text{C}$
Thermal Shutdown								
Temperature, $T_J$			175			*		$^\circ\text{C}$
Thermal Resistance, $\theta_{JA}$	"P" Package <sup>(3)</sup>		100			*		$^\circ\text{C}/\text{W}$
$\theta_{JA}$	"U" Package <sup>(3)</sup>		150			*		$^\circ\text{C}/\text{W}$
$\theta_{JA}$	"T" Package <sup>(3)</sup>		65			*		$^\circ\text{C}/\text{W}$
$\theta_{JC}$	"T" Package		6			*		$^\circ\text{C}/\text{W}$
$\theta_{JA}$	"F" Package <sup>(3)</sup>		65			*		$^\circ\text{C}/\text{W}$
$\theta_{JC}$	"F" Package		6			*		$^\circ\text{C}/\text{W}$
								

\* Specifications the same as Low Quiescent Mode.

NOTES: (1) Tests are performed on high speed automatic test equipment, at approximately  $25^\circ\text{C}$  junction temperature. The power dissipation of this product will cause some parameters to shift when warmed up. See typical performance curves for over-temperature performance. (2) Limited output swing available at low supply voltage. See Output voltage specifications. (3) Typical when all leads are soldered to a circuit board. See text for recommendations.

The information provided herein is believed to be reliable; however, BURR-BROWN assumes no responsibility for inaccuracies or omissions. BURR-BROWN assumes no responsibility for the use of this information, and all use of such information shall be entirely at the user's own risk. Prices and specifications are subject to change without notice. No patent rights or licenses to any of the circuits described herein are implied or granted to any third party. BURR-BROWN does not authorize or warrant any BURR-BROWN product for use in life support devices and/or systems.

## PIN CONFIGURATION

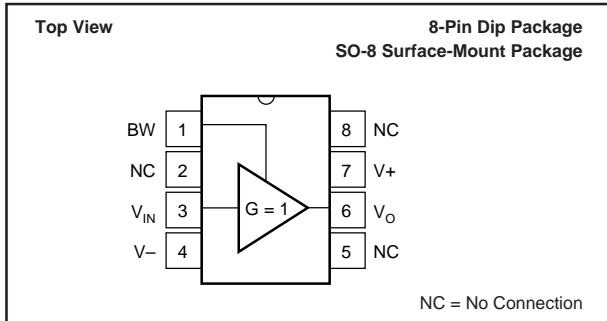

## ABSOLUTE MAXIMUM RATINGS

Supply Voltage .....	$\pm 18V$
Input Voltage Range .....	$\pm V_S$
Output Short-Circuit (to ground) .....	Continuous
Operating Temperature .....	$-40^{\circ}C$ to $+125^{\circ}C$
Storage Temperature .....	$-55^{\circ}C$ to $+125^{\circ}C$
Junction Temperature .....	$+150^{\circ}C$
Lead Temperature (soldering, 10s) .....	$+300^{\circ}C$

## PACKAGE/ORDERING INFORMATION

PRODUCT	PACKAGE	PACKAGE DRAWING NUMBER <sup>(1)</sup>	TEMPERATURE RANGE
BUF634P	8-Pin Plastic DIP	006	$-40^{\circ}C$ to $+85^{\circ}C$
BUF634U	SO-8 Surface-Mount	182	$-40^{\circ}C$ to $+85^{\circ}C$
BUF634T	5-Lead TO-220	315	$-40^{\circ}C$ to $+85^{\circ}C$
BUF634F	5-Lead DPAK	325	$-40^{\circ}C$ to $+85^{\circ}C$

NOTE: (1) For detailed drawing and dimension table, please see end of data sheet, or Appendix C of Burr-Brown IC Data Book.

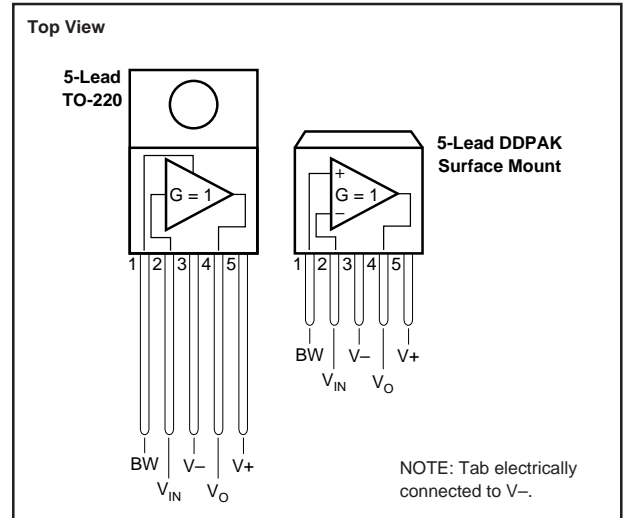

## ELECTROSTATIC DISCHARGE SENSITIVITY

Any integrated circuit can be damaged by ESD. Burr-Brown recommends that all integrated circuits be handled with appropriate precautions. Failure to observe proper handling and installation procedures can cause damage.

ESD damage can range from subtle performance degradation to complete device failure. Precision integrated circuits may be more susceptible to damage because very small parametric changes could cause the device not to meet published specifications.

# TYPICAL PERFORMANCE CURVES

At  $T_A = +25^\circ\text{C}$ ,  $V_S = \pm 15\text{V}$ , unless otherwise noted.

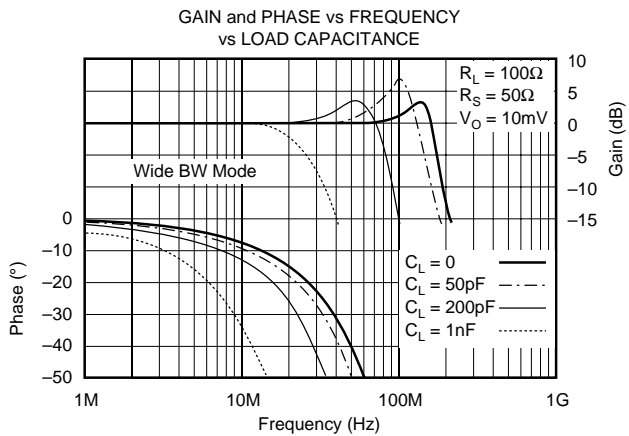
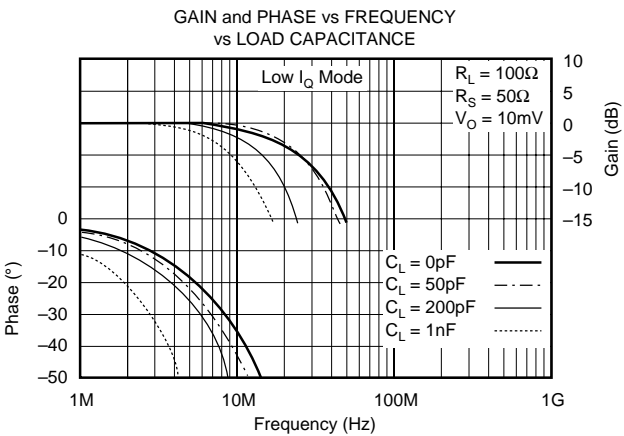
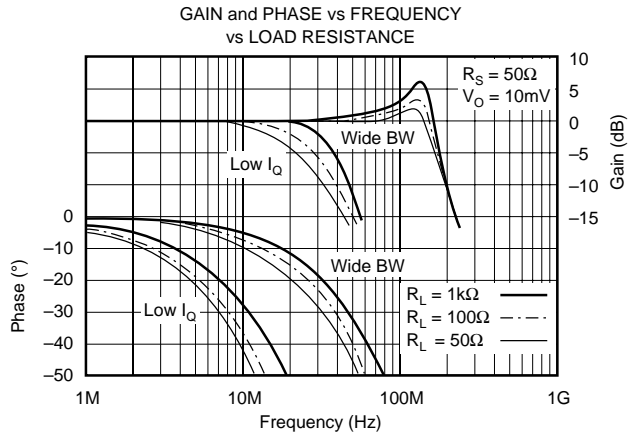
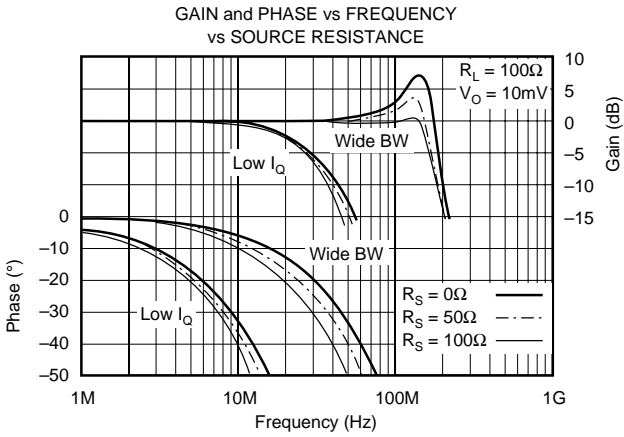
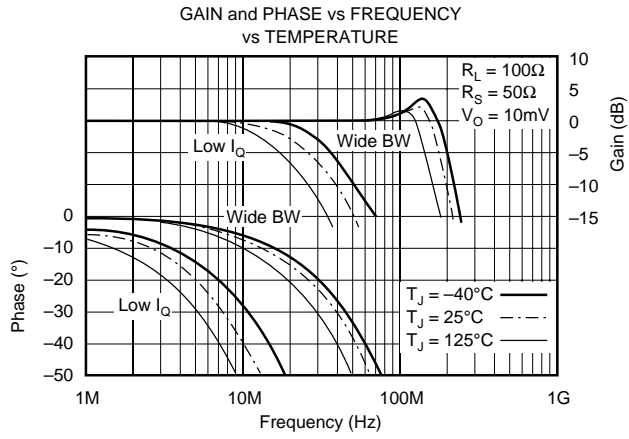
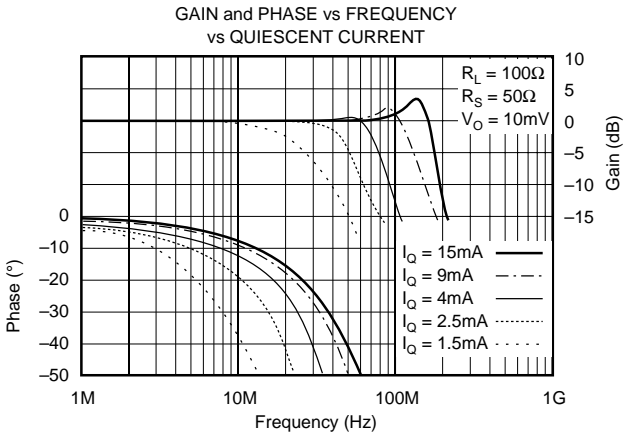

# TYPICAL PERFORMANCE CURVES (CONT)

At  $T_A = +25^\circ\text{C}$ ,  $V_S = \pm 15\text{V}$ , unless otherwise noted.

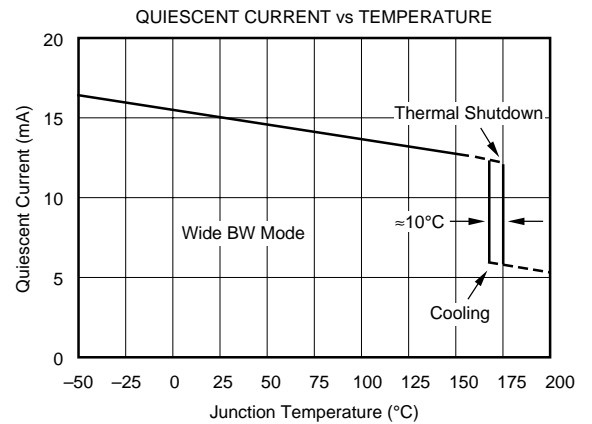
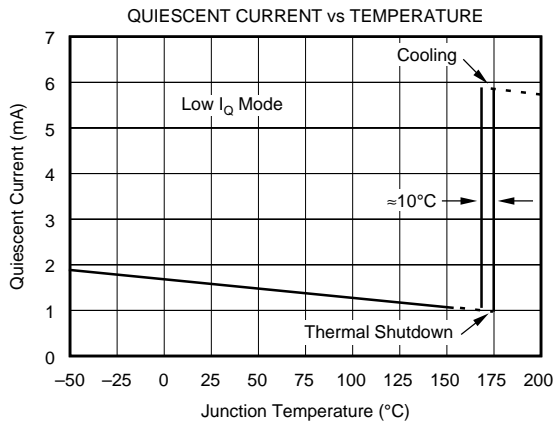
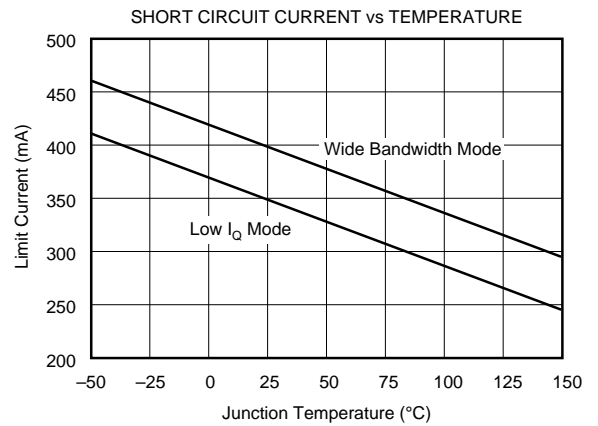
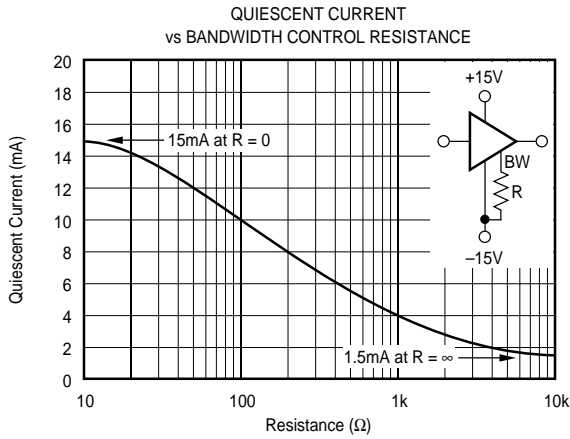
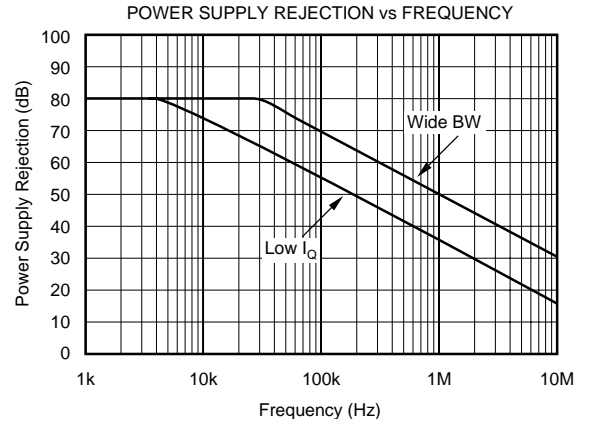
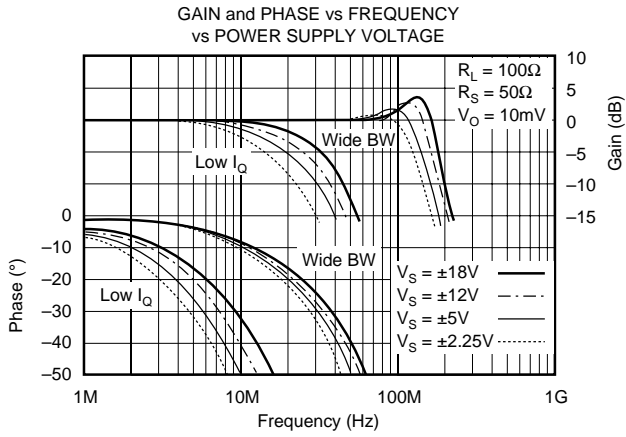

# TYPICAL PERFORMANCE CURVES (CONT)

At  $T_A = +25^\circ\text{C}$ ,  $V_S = \pm 15\text{V}$ , unless otherwise noted.

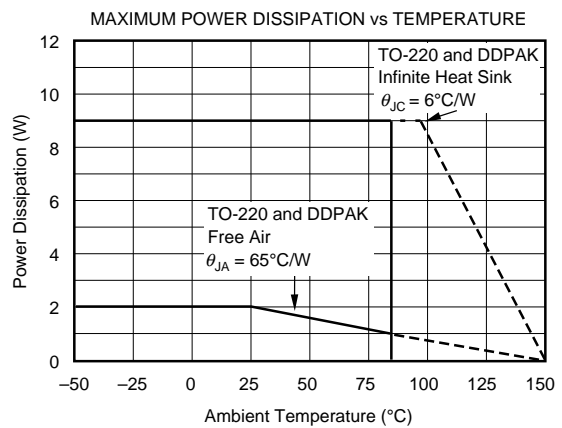
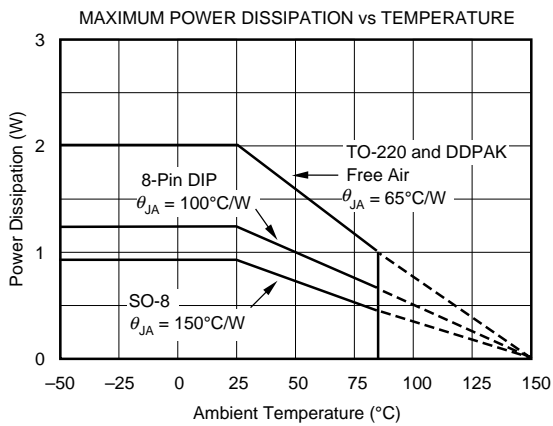
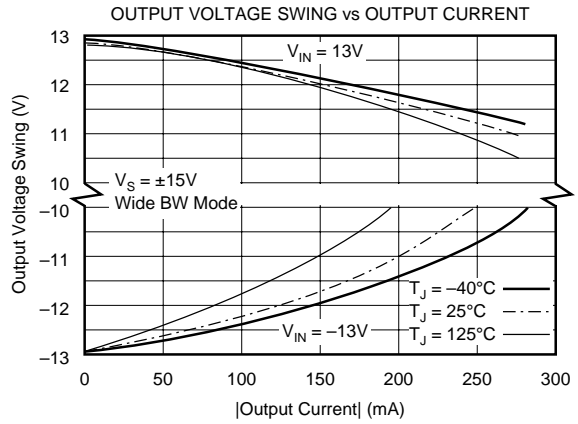
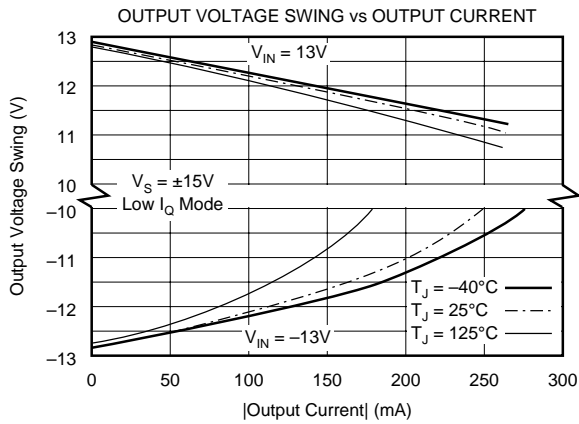

SMALL-SIGNAL RESPONSE  
 $R_S = 50\Omega$ ,  $R_L = 100\Omega$

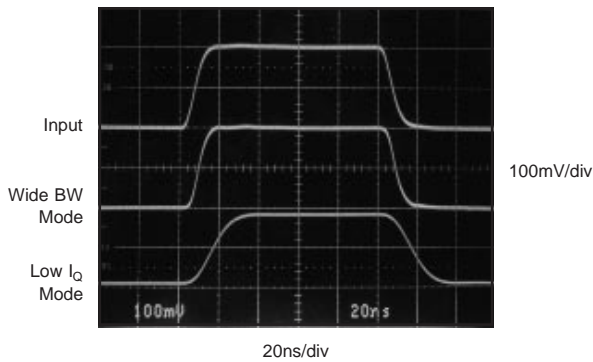

LARGE-SIGNAL RESPONSE  
 $R_S = 50\Omega$ ,  $R_L = 100\Omega$

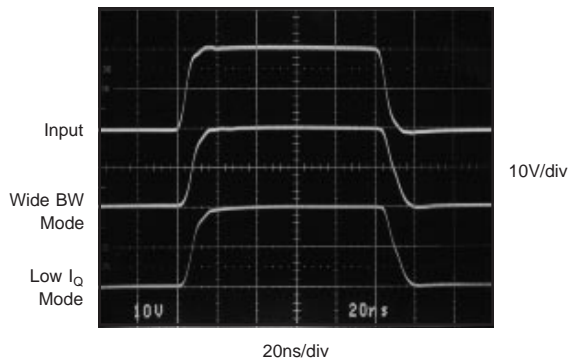

## APPLICATION INFORMATION

Figure 1 is a simplified circuit diagram of the BUF634 showing its open-loop complementary follower design.

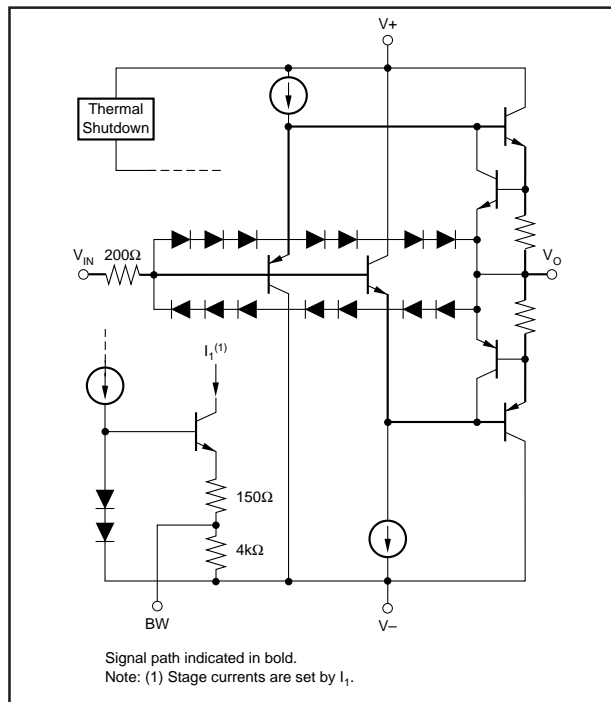

FIGURE 1. Simplified Circuit Diagram.

Figure 2 shows the BUF634 connected as an open-loop buffer. The source impedance and optional input resistor,  $R_S$ , influence frequency response—see typical curves. Power supplies should be bypassed with capacitors connected close to the device pins. Capacitor values as low as 0.1 $\mu$ F will assure stable operation in most applications, but high output current and fast output slewing can demand large current transients from the power supplies. Solid tantalum 10 $\mu$ F capacitors are recommended.

High frequency open-loop applications may benefit from special bypassing and layout considerations—see “High Frequency Applications” at end of applications discussion.

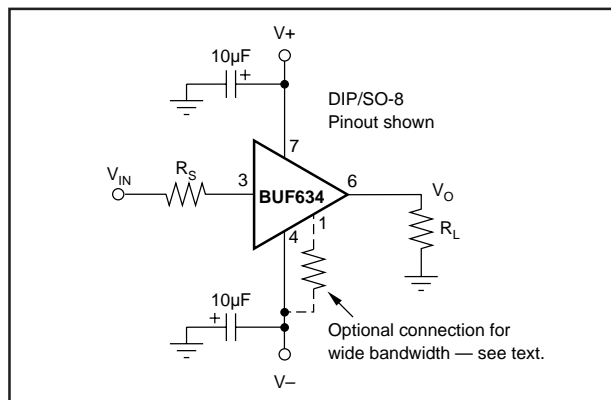

FIGURE 2. Buffer Connections.

## OUTPUT CURRENT

The BUF634 can deliver up to  $\pm 250$ mA continuous output current. Internal circuitry limits output current to approximately  $\pm 350$ mA—see typical performance curve “Short Circuit Current vs Temperature”. For many applications, however, the continuous output current will be limited by thermal effects.

The output voltage swing capability varies with junction temperature and output current—see typical curves “Output Voltage Swing vs Output Current.” Although all four package types are tested for the same output performance using a high speed test, the higher junction temperatures with the DIP and SO-8 package types will often provide less output voltage swing. Junction temperature is reduced in the DDPACK surface-mount power package because it is soldered directly to the circuit board. The TO-220 package used with a good heat sink further reduces junction temperature, allowing maximum possible output swing.

## THERMAL PROTECTION

Power dissipated in the BUF634 will cause the junction temperature to rise. A thermal protection circuit in the BUF634 will disable the output when the junction temperature reaches approximately 175°C. When the thermal protection is activated, the output stage is disabled, allowing the device to cool. Quiescent current is approximately 6mA during thermal shutdown. When the junction temperature cools to approximately 165°C the output circuitry is again enabled. This can cause the protection circuit to cycle on and off with a period ranging from a fraction of a second to several minutes or more, depending on package type, signal, load and thermal environment.

The thermal protection circuit is designed to prevent damage during abnormal conditions. Any tendency to activate the thermal protection circuit during normal operation is a sign of an inadequate heat sink or excessive power dissipation for the package type.

TO-220 package provides the best thermal performance. When the TO-220 is used with a properly sized heat sink, output is not limited by thermal performance. See Application Bulletin AB-037 for details on heat sink calculations. The DDPACK also has excellent thermal characteristics. Its mounting tab should be soldered to a circuit board copper area for good heat dissipation. Figure 3 shows typical thermal resistance from junction to ambient as a function of the copper area. The mounting tab of the TO-220 and DDPACK packages is electrically connected to the  $V-$  power supply.

The DIP and SO-8 surface-mount packages are excellent for applications requiring high output current with low average power dissipation. To achieve the best possible thermal performance with the DIP or SO-8 packages, solder the device directly to a circuit board. Since much of the heat is dissipated by conduction through the package pins, sockets will degrade thermal performance. Use wide circuit board traces on all the device pins, including pins that are not connected. With the DIP package, use traces on both sides of the printed circuit board if possible.

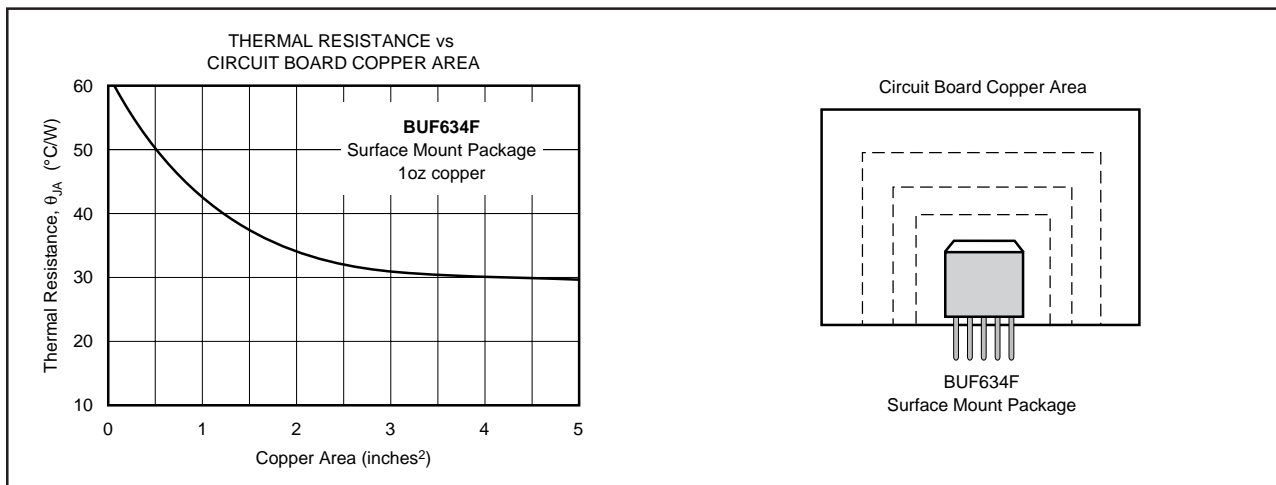

FIGURE 3. Thermal Resistance vs Circuit Board Copper Area.

### POWER DISSIPATION

Power dissipation depends on power supply voltage, signal and load conditions. With DC signals, power dissipation is equal to the product of output current times the voltage across the conducting output transistor,  $V_S - V_O$ . Power dissipation can be minimized by using the lowest possible power supply voltage necessary to assure the required output voltage swing.

For resistive loads, the maximum power dissipation occurs at a DC output voltage of one-half the power supply voltage. Dissipation with AC signals is lower. Application Bulletin AB-039 explains how to calculate or measure power dissipation with unusual signals and loads.

Any tendency to activate the thermal protection circuit indicates excessive power dissipation or an inadequate heat sink. For reliable operation, junction temperature should be limited to 150°C, maximum. To estimate the margin of safety in a complete design, increase the ambient temperature until the thermal protection is triggered. The thermal protection should trigger more than 45°C above the maximum expected ambient condition of your application.

### INPUT CHARACTERISTICS

Internal circuitry is protected with a diode clamp connected from the input to output of the BUF634—see Figure 1. If the output is unable to follow the input within approximately 3V (such as with an output short-circuit), the input will conduct increased current from the input source. This is limited by the internal 200Ω resistor. If the input source can be damaged by this increase in load current, an additional resistor can be connected in series with the input.

### BANDWIDTH CONTROL PIN

The -3dB bandwidth of the BUF634 is approximately 30MHz in the low quiescent current mode (1.5mA typical). To select this mode, leave the bandwidth control pin open (no connection).

Bandwidth can be extended to approximately 180MHz by connecting the bandwidth control pin to V-. This increases

the quiescent current to approximately 15mA. Intermediate bandwidths can be set by connecting a resistor in series with the bandwidth control pin—see typical curve "Quiescent Current vs Resistance" for resistor selection. Characteristics of the bandwidth control pin can be seen in the simplified circuit diagram, Figure 1.

The rated output current and slew rate are not affected by the bandwidth control, but the current limit value changes slightly. Output voltage swing is somewhat improved in the wide bandwidth mode. The increased quiescent current when in wide bandwidth mode produces greater power dissipation during low output current conditions. This quiescent power is equal to the total supply voltage,  $(V+) + |(V-)|$ , times the quiescent current.

### BOOSTING OP AMP OUTPUT CURRENT

The BUF634 can be connected inside the feedback loop of most op amps to increase output current—see Figure 4. When connected inside the feedback loop, the BUF634's offset voltage and other errors are corrected by the feedback of the op amp.

To assure that the op amp remains stable, the BUF634's phase shift must remain small throughout the loop gain of the circuit. For a  $G=+1$  op amp circuit, the BUF634 must contribute little additional phase shift (approximately 20° or less) at the unity-gain frequency of the op amp. Phase shift is affected by various operating conditions that may affect stability of the op amp—see typical Gain and Phase curves.

Most general-purpose or precision op amps remain unity-gain stable with the BUF634 connected inside the feedback loop as shown. Large capacitive loads may require the BUF634 to be connected for wide bandwidth for stable operation. High speed or fast-settling op amps generally require the wide bandwidth mode to remain stable and to assure good dynamic performance. To check for stability with an op amp, look for oscillations or excessive ringing on signal pulses with the intended load and worst case conditions that affect phase response of the buffer.

## HIGH FREQUENCY APPLICATIONS

The BUF634's excellent bandwidth and fast slew rate make it useful in a variety of high frequency open-loop applications. When operated open-loop, circuit board layout and bypassing technique can affect dynamic performance.

For best results, use a ground plane type circuit board layout and bypass the power supplies with 0.1 $\mu$ F ceramic chip

capacitors at the device pins in parallel with solid tantalum 10 $\mu$ F capacitors. Source resistance will affect high-frequency peaking and step response overshoot and ringing. Best response is usually achieved with a series input resistor of 25 $\Omega$  to 200 $\Omega$ , depending on the signal source. Response with some loads (especially capacitive) can be improved with a resistor of 10 $\Omega$  to 150 $\Omega$  in series with the output.

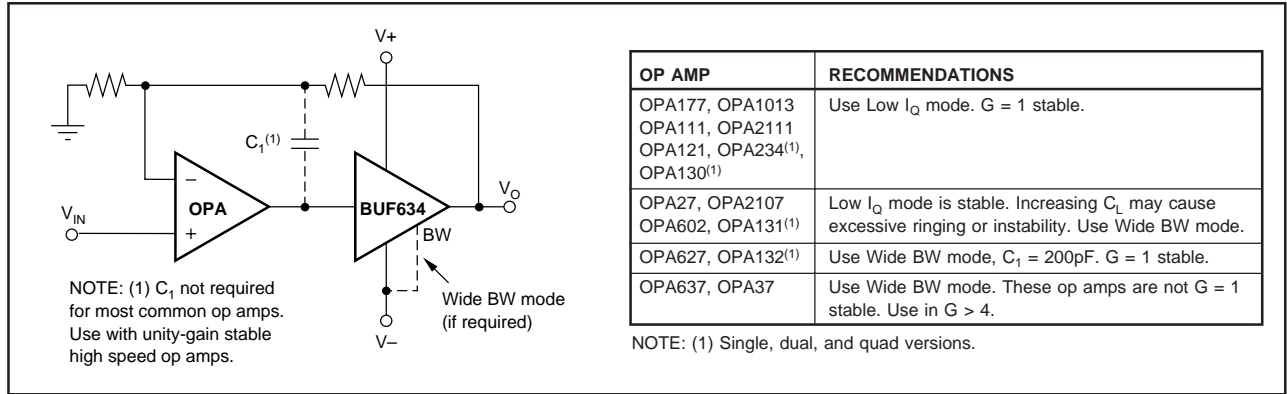

FIGURE 4. Boosting Op Amp Output Current.

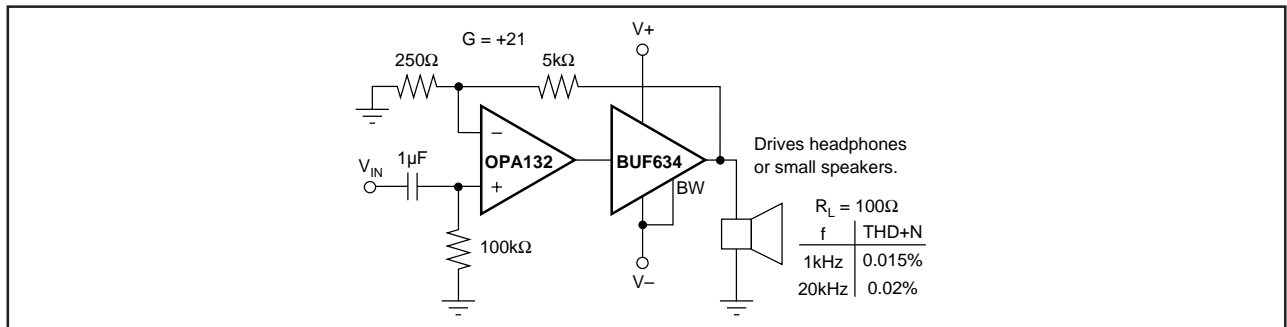

FIGURE 5. High Performance Headphone Driver.

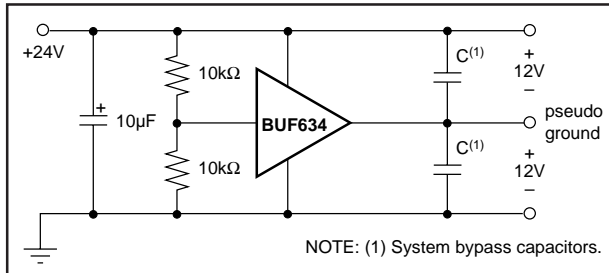

FIGURE 6. Pseudo-Ground Driver.

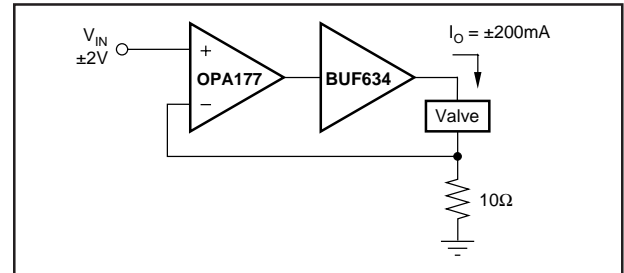

FIGURE 7. Current-Output Valve Driver.

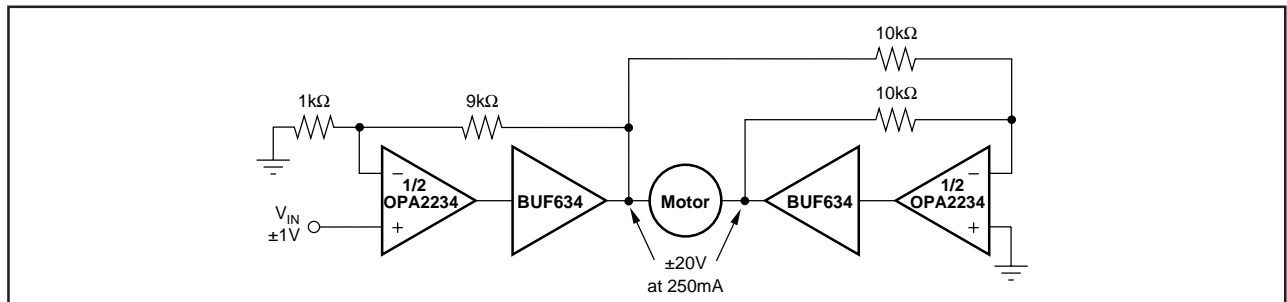

FIGURE 8. Bridge-Connected Motor Driver.

This datasheet has been downloaded from:

[www.DatasheetCatalog.com](http://www.DatasheetCatalog.com)

Datasheets for electronic components.



LittleDiode supplies new, hard to find or obsolete electronic components and semiconductors all over the world.

With over two million different components listed you are sure to find the part you need.

Feel free to visit us today at our online store:

[LittleDiode.com](http://LittleDiode.com)

Looking forward to providing you with the best possible service.