

CM2021-02TR

HDMI Receiver Port Protection and Interface Device

Product Description

The CM2021-02TR HDMI Receiver Port Protection and Interface Device is specifically designed for next generation HDMI Host interface protection.

An integrated package provides all ESD, level shift and backdrive protection for an HDMI port in a single 38-Pin TSSOP package.

The CM2021-02TR part is specifically designed to complement the CM2020 protection part in HDMI transmitters (DVD, STB/OPVR, etc.).

Features

- HDMI 1.3 Compliant
- 0.05 pF Matching Capacitance between the TMDS Intra-Pair
- Level Shifting/Isolation Circuitry
- Provides ESD Protection to IEC61000-4-2 Level 4:
 - ◆ ±8 kV Contact Discharge
 - ◆ ±15 kV Air Discharge
- Matched 0.5 mm Trace Spacing (TSSOP)
- Simplified Layout for HDMI Connectors
- Backdrive Protection
- These Devices are Pb-Free and are RoHS Compliant

Applications

- PC
- Consumer Electronics
- Displays and Digital Television



ON Semiconductor®

<http://onsemi.com>

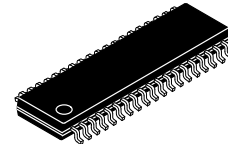

TSSOP 38
TR SUFFIX
CASE 948AG

MARKING DIAGRAM

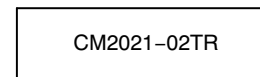

CM2021-02TR = Specific Device Code

ORDERING INFORMATION

Device	Package	Shipping [†]
CM2021-02TR	TSSOP-38 (Pb-Free)	2500/Tape & Reel

[†]For information on tape and reel specifications, including part orientation and tape sizes, please refer to our Tape and Reel Packaging Specification Brochure, BRD8011/D.

CM2021-02TR

ELECTRICAL SCHEMATIC

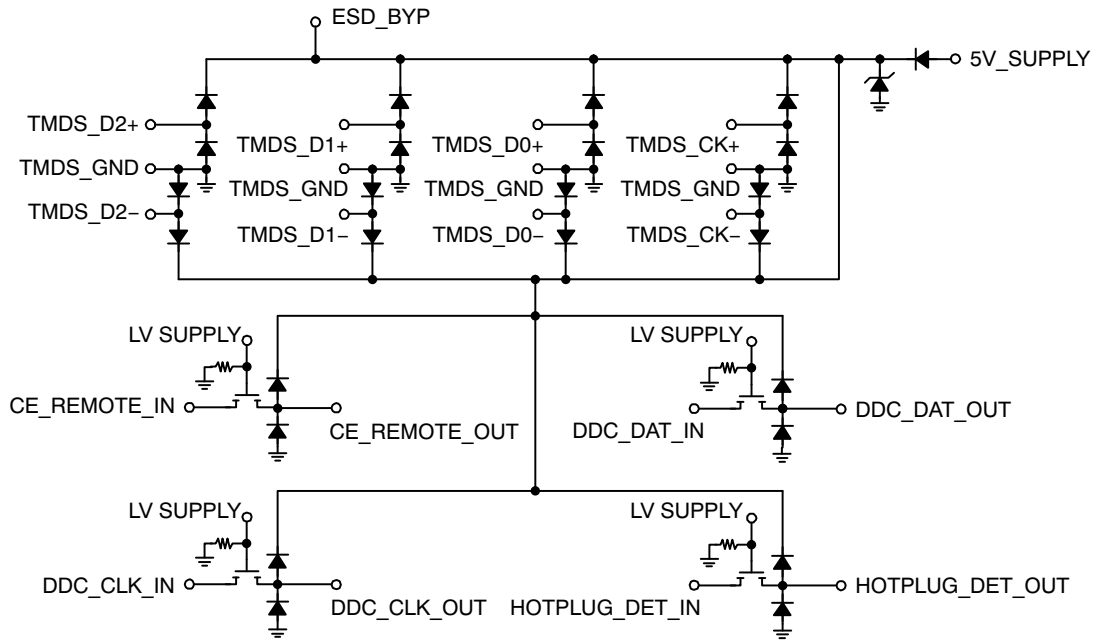

PACKAGE / PINOUT DIAGRAM

Top View

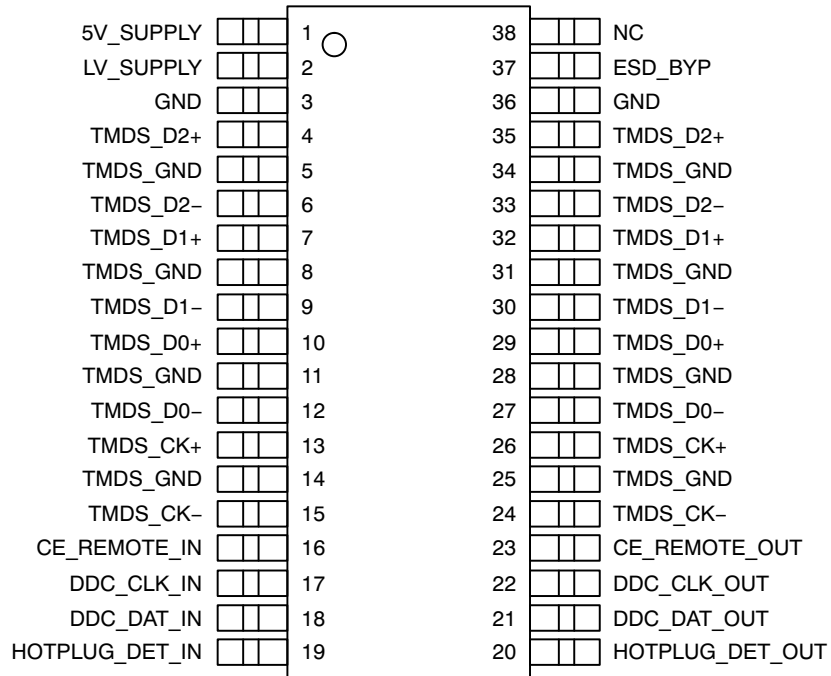

38-Pin TSSOP Package

Table 1. PIN DESCRIPTIONS

Pins	Name	ESD Level	Description
4, 35	TMDS_D2+	8 kV (Note 2)	TMDS 0.9 pF ESD Protection (Note 1)
6, 33	TMDS_D2-	8 kV (Note 2)	TMDS 0.9 pF ESD Protection (Note 1)
7, 32	TMDS_D1+	8 kV (Note 2)	TMDS 0.9 pF ESD Protection (Note 1)
9, 30	TMDS_D1-	8 kV (Note 2)	TMDS 0.9 pF ESD Protection (Note 1)
10, 29	TMDS_D0+	8 kV (Note 2)	TMDS 0.9 pF ESD Protection (Note 1)
12, 27	TMDS_D0-	8 kV (Note 2)	TMDS 0.9 pF ESD Protection (Note 1)
13, 26	TMDS_CK+	8 kV (Note 2)	TMDS 0.9 pF ESD Protection (Note 1)
15, 24	TMDS_CK-	8 kV (Note 2)	TMDS 0.9 pF ESD Protection (Note 1)
16	CE_REMOTE_IN	2 kV (Note 3)	LV_SUPPLY Referenced Logic Level into ASIC
23	CE_REMOTE_OUT	8 kV (Note 2)	5V_SUPPLY Referenced Logic Level Out plus 3.5 pF ESD to Connector
17	DDC_CLK_IN	2 kV (Note 3)	LV_SUPPLY Referenced Logic Level into ASIC
22	DDC_CLK_OUT	8 kV (Note 2)	5V_SUPPLY Referenced Logic Level Out plus 3.5 pF ESD to Connector
18	DDC_DAT_IN	2 kV (Note 3)	LV_SUPPLY Referenced Logic Level into ASIC
21	DDC_DAT_OUT	8 kV (Note 2)	5V_SUPPLY Referenced Logic Level Out plus 3.5 pF ESD to Connector
19	HOTPLUG_DET_IN	2 kV (Note 3)	LV_SUPPLY Referenced Logic Level into ASIC
20	HOTPLUG_DET_OUT	8 kV (Note 2)	5V_SUPPLY Referenced Logic Level Out plus 3.5 pF ESD to Connector
2	LV_SUPPLY	2 kV (Note 3)	Bias for CE / DDC / HOTPLUG Level Shifters
1	5V_SUPPLY	2 kV (Note 3)	Current Source for 5V_OUT
37	ESD_BYP	2 kV (Note 3)	This Pin may be Connected to a 0.1 μ F Ceramic Capacitor, but it is not necessary.
5, 34, 8, 31, 11, 28, 14, 25	TMDS_GND	N/A	TMDS ESD and Parasitic GND Return (Note 4)
3, 36	GND	N/A	Supply GND Reference
38	NC	N/A	No Connect

1. These 2 pins need to be connected together in-line on the PCB.
2. Standard IEC 61000-4-2, $C_{DISCHARGE} = 150$ pF, $R_{DISCHARGE} = 330$ Ω , 5V_SUPPLY and LV_SUPPLY within recommended operating conditions, GND = 0 V, each bypassed with a 0.1 μ F ceramic capacitor connected to GND.
3. Human Body Model per MIL-STD-883, Method 3015, $C_{DISCHARGE} = 100$ pF, $R_{DISCHARGE} = 1.5$ k Ω , 5V_SUPPLY and LV_SUPPLY within recommended operating conditions, GND = 0 V, and each bypassed with a 0.1 μ F ceramic capacitor connected to GND.
4. These pins should be routed directly to the associated GND pins on the HDMI connector with single point ground vias at the connector.

BACKDRIVE PROTECTION

Two scenarios below describe what can happen when a powered device is connected to an unpowered device via an HDMI interface, substantiating the need for backdrive protection for this type of interface.

In a classic scenario, a DVD player is connected to a TV via an HDMI interface. If the DVD player is switched off and the TV is left on, there is a possibility of reverse current flow back into the main power supply rail of the DVD player. Typically, the DVD’s power supply has some form of bulk supply capacitance associated with it. Because all CMOS logic exhibits a very high impedance on the power rail node when “off,” if there is very little parasitic shunt resistance and as little as a few milliamps of “backdrive” current flowing back into the power rail, it is possible over time to charge that bulk supply capacitance to some intermediate level. If this level rises above the power-on-reset (POR) voltage level of some of the integrated circuits in the DVD player, these devices may not reset properly when the DVD player is turned back on.

In a more serious scenario, if any SOC devices are incorporated in the design which have built-in level shifter and DRC diodes for ESD protection, there is even a higher risk for damage. In this case, if there is a pullup resistor (such as with DDC) on the other end of the cable, that resistance will pull the SOC chips “output” up to a high level. This will forward bias the upper ESD diode in the DRC and charge the bulk capacitance in a similar fashion like above. If the current flow is high enough, even as little as a few milliamps, it could destroy one of the SOC chip’s internal DRC diodes, as they are not designed for passing DC.

To avoid either of these situations, the CM2021-02TR is designed to block backdrive current, guaranteeing no more than 5 μ A on any I/O pin when the I/O pin voltage is greater than the CM2021-02TR supply voltage.

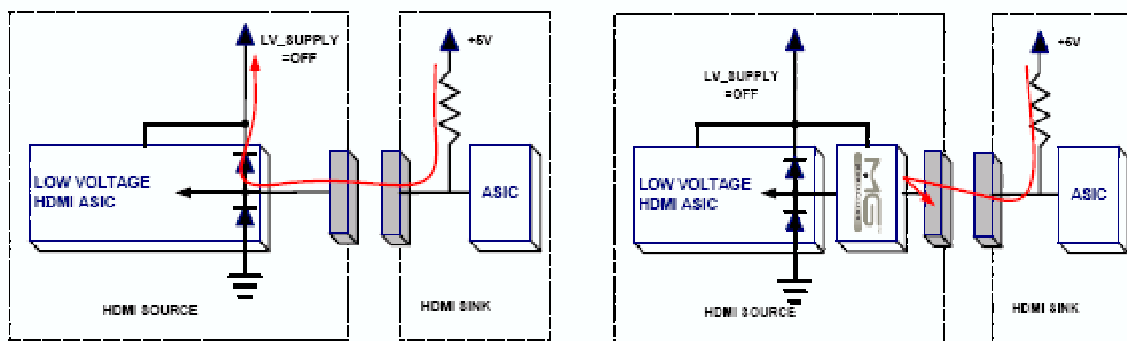

Figure 1. Backdrive Protection Diagram.

SPECIFICATIONS

Table 2. ABSOLUTE MAXIMUM RATINGS

Parameter	Rating	Units
V_{CC5V}, V_{CCLV}	6.0	V
DC Voltage at any Channel Input	6.0	V
Storage Temperature Range	-65 to +150	°C

Stresses exceeding Maximum Ratings may damage the device. Maximum Ratings are stress ratings only. Functional operation above the Recommended Operating Conditions is not implied. Extended exposure to stresses above the Recommended Operating Conditions may affect device reliability.

Table 3. STANDARD (RECOMMENDED) OPERATING CONDITIONS

Symbol	Parameter	Min	Typ	Max	Units
5V_SUPPLY	Operating Supply Voltage	GND	5	5.5	V
LV_SUPPLY	Bias Supply Voltage	1	3.3	5.5	V
-	Operating Temperature Range	-40	-	85	°C

CM2021-02TR

SPECIFICATIONS (Cont'd)

Table 4. ELECTRICAL OPERATING CHARACTERISTICS (Note 1)

Symbol	Parameter	Conditions	Min	Typ	Max	Units
I _{CC5V}	Operating Supply Current	5V_SUPPLY = 5.0 V		110	130	μA
I _{CCLV}	Bias Supply Current	LV_SUPPLY = 3.3 V		1	5	μA
I _{OFF}	OFF State Leakage Current, Level Shifting NFET	LV_SUPPLY = 0 V		0.1	5.0	μA
I _{BACKDRIVE}	Current Conducted from Output Pins to V_SUPPLY Rails when Powered Down	5V_SUPPLY < V _{CH_OUT} Signal Pins: TMDS_D[2:0]±/±-, TMDS_CK±/±-, CE_REMOTE_OUT, DDC_DAT_OUT, DDC_CLK_OUT, HOTPLUG_DET_OUT Only		0.1	5.0	μA
I _{BACKDRIVE, CEC}	Current through CE-REMOTE_OUT when Powered Down	CE-REMOTE_IN = CE_SUPPLY < CE_REMOTE_OUT		0.1	1.0	μA
V _{ON}	VOLTAGE Drop Across Level Shifting NFET when ON	LV_SUPPLY = 2.5 V, V _S = GND, I _{DS} = 3 mA	75	95	140	mV
V _F	Diode Forward Voltage Top Diode Bottom Diode	I _F = 8 mA, T _A = 25°C (Note 2)	0.60 0.60	0.85 0.85	0.95 0.95	V
V _{ESD}	ESD Withstand Voltage (IEC)	Pins 4, 7, 10, 13, 20, 21, 22, 23, 24, 27, 30, 33 (Notes 2 and 3)	8			kV
V _{CL}	Channel Clamp Voltage Positive Transients Negative Transients	T _A = 25°C, I _{PP} = 1 A, t _p = 8/20 μs (Notes 2 and 4)		11.0 -2.0		V
R _{DYN}	Dynamic Resistance Positive Transients Negative Transients	T _A = 25°C, I _{PP} = 1 A, t _p = 8/20 μs (Notes 2 and 4)		1.2 0.9		Ω
I _{LEAK}	TMDS Channel Leakage Current	T _A = 25°C (Note 2)		0.01	1	μA
C _{IN, TMDS}	TMDS Channel Input Capacitance	5V_SUPPLY = 5.0 V, Measured at 1 MHz, V _{BIAS} = 2.5 V (Note 2)		0.9	1.2	pF
ΔC _{IN, TMDS}	TMDS Channel Input Capacitance Matching	5V_SUPPLY = 5.0 V, Measured at 1 MHz, V _{BIAS} = 2.5 V (Note 2 and 5)		0.05		pF
C _{IN, DDC}	Level Shifting Input Capacitance, Capacitance to GND	5V_SUPPLY = 5 V, Measured at 100 kHz, V _{BIAS} = 2.5 V (Note 2)		3.5	4	pF
C _{IN, CEC}	Level Shifting Input Capacitance, Capacitance to GND	5V_SUPPLY = 5 V, Measured at 100 kHz, V _{BIAS} = 2.5 V (Note 2)		3.5	4	pF
C _{IN, HP}	Level Shifting Input Capacitance, Capacitance to GND	5V_SUPPLY = 5 V, Measured at 100 kHz, V _{BIAS} = 2.5 V (Note 2)		3.5	4	pF

1. Operating Characteristics are over Standard Operating Conditions unless otherwise specified.
2. This parameter is guaranteed by design and verified by device characterization.
3. Standard IEC 61000-4-2, C_{DISCHARGE} = 150 pF, R_{DISCHARGE} = 330 Ω, 5V_SUPPLY and LV_SUPPLY within recommended operating conditions, GND = 0 V, each bypassed with a 0.1 μF ceramic capacitor connected to GND.
4. These measurements performed with no external capacitor on ESD_BYP.
5. Intra-pair matching, each TMDS pair (i.e. D+, D-).

CM2021-02TR

PERFORMANCE INFORMATION

Typical Filter Performance ($T_A = 25^\circ\text{C}$, DC Bias = 0 V, 50 Ω Environment)

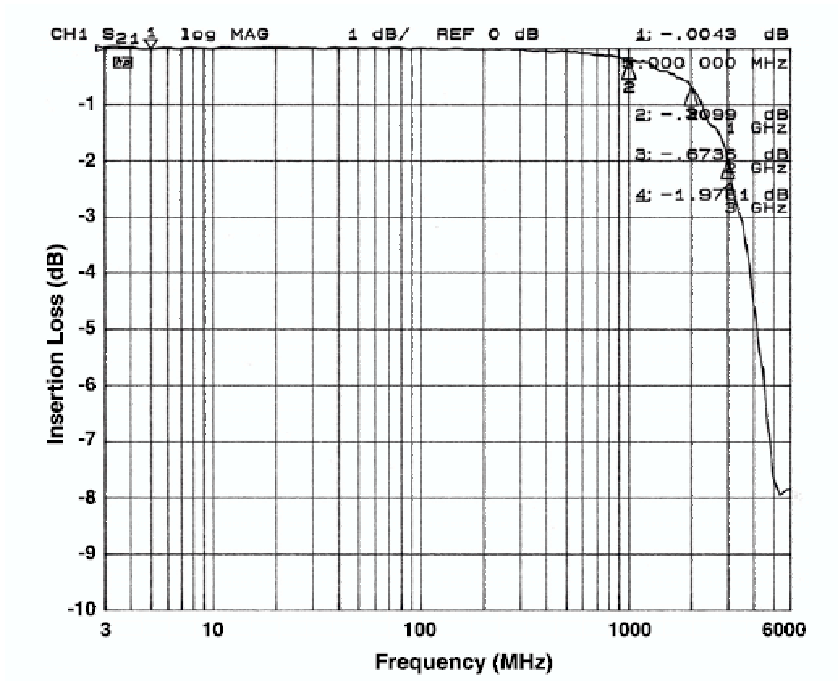
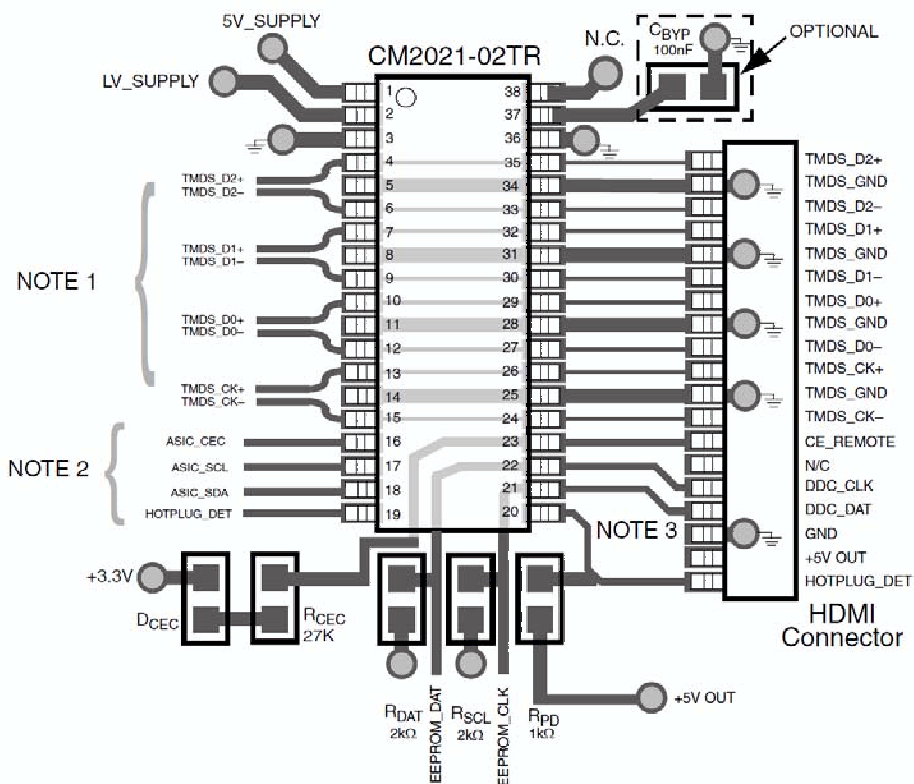

Figure 2. Insertion Loss vs. Frequency (TMDS_D1- to GND)

CM2021-02TR

APPLICATION INFORMATION



LAYOUT NOTES

NOTE 1) Differential TMDS Pairs should be designed as normal 100 Ω HDMI microstrip. Single Ended TMDS traces underneath CM2021 and between CM2021 and Connector should be tuned to match chip/connector parasitics. (See MediaGuard™ Application Notes.)

NOTE 2) Level Shifter signals should be biased with a weak pullup to the desired local LV_SUPPLY. If the local ASIC includes sufficient pullups to register a logic high when the CM2021 NFET is "off", then external pullups are not needed.

NOTE 3) Place CM2021 as close to conector as possible, and as with any controlled impedance line avoid ANY silkscreening over TMDS lines.

Figure 3. Typical Application for CM2021-02TR

CM2021-02TR

PACKAGE DIMENSIONS

TSSOP 38
CASE 948AG-01
ISSUE O

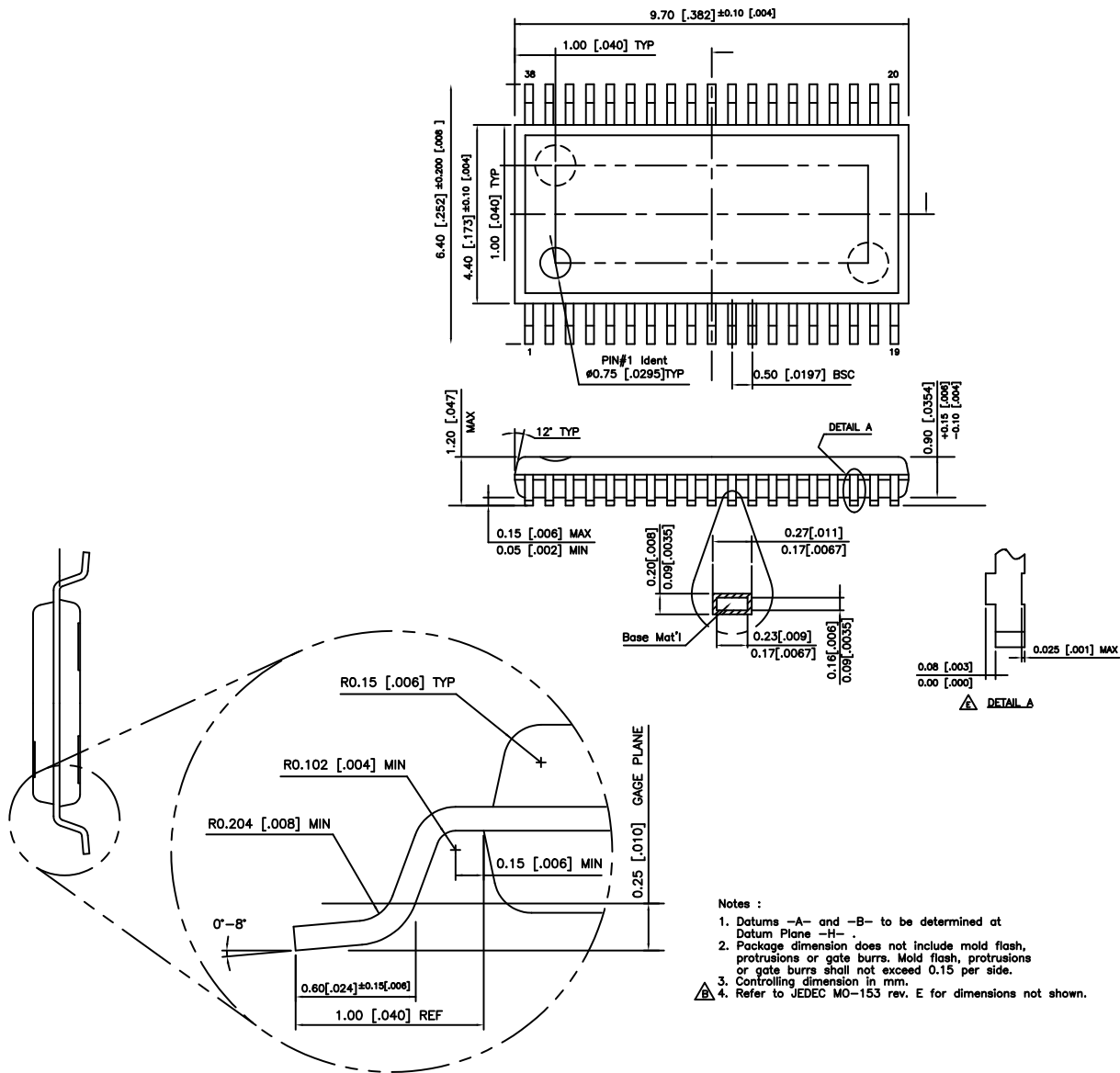

- Notes :
1. Datums -A- and -B- to be determined at Datum Plane -H-.
 2. Package dimension does not include mold flash, protrusions or gate burrs. Mold flash, protrusions or gate burrs shall not exceed 0.15 per side.
 3. Controlling dimension in mm.
 4. Refer to JEDEC MO-153 rev. E for dimensions not shown.

MediaGuard is a trademark of Nagra France.

ON Semiconductor and are registered trademarks of Semiconductor Components Industries, LLC (SCILLC). SCILLC reserves the right to make changes without further notice to any products herein. SCILLC makes no warranty, representation or guarantee regarding the suitability of its products for any particular purpose, nor does SCILLC assume any liability arising out of the application or use of any product or circuit, and specifically disclaims any and all liability, including without limitation special, consequential or incidental damages. "Typical" parameters which may be provided in SCILLC data sheets and/or specifications can and do vary in different applications and actual performance may vary over time. All operating parameters, including "Typicals" must be validated for each customer application by customer's technical experts. SCILLC does not convey any license under its patent rights nor the rights of others. SCILLC products are not designed, intended, or authorized for use as components in systems intended for surgical implant into the body, or other applications intended to support or sustain life, or for any other application in which the failure of the SCILLC product could create a situation where personal injury or death may occur. Should Buyer purchase or use SCILLC products for any such unintended or unauthorized application, Buyer shall indemnify and hold SCILLC and its officers, employees, subsidiaries, affiliates, and distributors harmless against all claims, costs, damages, and expenses, and reasonable attorney fees arising out of, directly or indirectly, any claim of personal injury or death associated with such unintended or unauthorized use, even if such claim alleges that SCILLC was negligent regarding the design or manufacture of the part. SCILLC is an Equal Opportunity/Affirmative Action Employer. This literature is subject to all applicable copyright laws and is not for resale in any manner.

PUBLICATION ORDERING INFORMATION

LITERATURE FULFILLMENT:
Literature Distribution Center for ON Semiconductor
P.O. Box 5163, Denver, Colorado 80217 USA
Phone: 303-675-2175 or 800-344-3860 Toll Free USA/Canada
Fax: 303-675-2176 or 800-344-3867 Toll Free USA/Canada
Email: orderlit@onsemi.com

N. American Technical Support: 800-282-9855 Toll Free
USA/Canada
Europe, Middle East and Africa Technical Support:
Phone: 421 33 790 2910
Japan Customer Focus Center
Phone: 81-3-5773-3850

ON Semiconductor Website: www.onsemi.com
Order Literature: <http://www.onsemi.com/orderlit>
For additional information, please contact your local Sales Representative



LittleDiode supplies new, hard to find or obsolete electronic components and semiconductors all over the world.

With over two million different components listed you are sure to find the part you need.

Feel free to visit us today at our online store:

LittleDiode.com

Looking forward to providing you with the best possible service.